

Oct. 22, 1935.

H. J. SCHORLE ET AL

2,018,096

PERCUSSIVE TOOL VALVE

Filed March 1, 1934

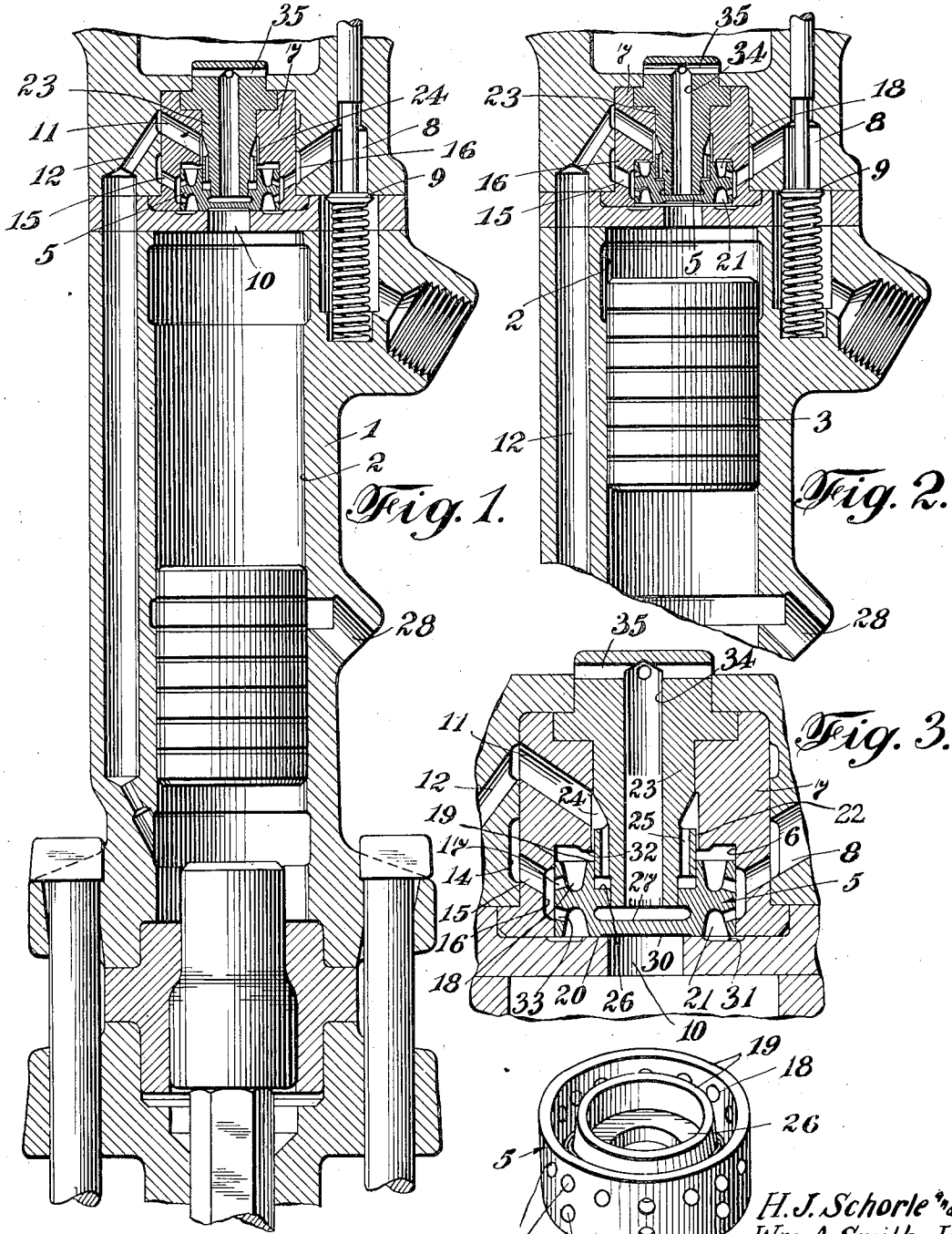

Fig. 1.

Fig. 2.

Fig. 3.

Fig. 4.

H. J. Schorle &
Wm. A. Smith Jr.
INVENTORS

BY *Robert Meyer*
ATTORNEY

UNITED STATES PATENT OFFICE

2,018,096

PERCUSSIVE TOOL VALVE

Herman J. Schorle, Astoria, N. Y., and William A. Smith, Jr., North Arlington, N. J., assignors to Worthington Pump and Machinery Corporation, New York, N. Y., a corporation of Virginia

Application March 1, 1934, Serial No. 713,514

4 Claims. (Cl. 121-19)

This invention relates to percussive tools and more particularly to valves therefor.

An object of the invention is to provide a valve relatively simple in construction, light in weight, positive and quick in action and one which will provide a heavy blow of the hammer piston of the tool and will cut down fluid consumption in proportion to the amount of work performed.

With these and other objects in view, as may appear from the accompanying specification, the invention consists of various features of construction and combination of parts, which will be first described in connection with the accompanying drawing, showing percussive tool valves of the preferred form embodying the invention, and the features forming the invention will be specifically pointed out in the claims.

In the drawing:

Fig. 1 is a fragmentary longitudinal section through a percussive tool showing the improved valve therein.

Fig. 2 is a fragmentary longitudinal section similar to Fig. 1 showing the valve in a different position than in which it is shown in Fig. 1.

Fig. 3 is an enlarged longitudinal section through the valve and valve chest.

Fig. 4 is an isometric view of the valve.

Referring more particularly to the drawing, the improved percussive tool includes a cylinder 1 having a piston chamber 2 therein in which the hammer piston 3 reciprocates. The hammer piston 3 is reciprocated by air under pressure or similar pressure fluid, the distribution of which is controlled by a valve 5 for controlling the operation of the piston.

The valve 5 reciprocates in the valve chamber 6 formed in the valve chest 7. The valve chest 7 is mounted in the rear end of the cylinder 1 and pressure fluid is fed thereto through a suitable inlet passage 8 controlled by a manually operated throttle valve 9.

The valve chamber 6 has a port 10 communicating therewith which delivers the fluid under pressure into the rear end of the cylinder 2 for driving the piston 3 forwardly and it has suitable ports or passages 11 therein which communicate in turn with suitable ports or passages 12 in the cylinder 1 for delivering the operating pressure fluid into the forward end of the cylinder 2 for driving the piston 3 rearwardly into the position as indicated in Fig. 2 of the drawing.

The fluid under pressure passing through the port 8 enters the annular channel 14 formed in the cylinder and passes from this annular channel 14 through suitable ports 15 into the annular

channel 16 formed in the valve chest 7. When the valve is in its lowered or forward position as shown in Figs. 1 and 3 of the drawing, the air under pressure passes through the ports 17 formed in the valve body into the annular channel 18. The annular channel 18 is cut in the rear face of the valve and this channel together with the rear surface of the valve as indicated at 19 forms a pressure area on the valve for holding it against the seat 20 to cut off communication between the annular channel 21 formed in the forward face of the valve and the port 10 and consequently cut off the flow of pressure fluid into the rear end of the cylinder 2. The pressure fluid passing through the ports 17 passes through a clearance space 22 formed between the valve chest 7 and the exterior of the valve guiding stem 23. The pressure fluid passing through the clearance space 22 enters the annular groove or channel 24 formed in the stem 23 and into the port 11, passing from the port 11 into the various ports 12 and thence to the forward end of the cylinder 2 where it acts to force the piston 3 rearwardly in the cylinder. A small part of the pressure fluid which passes through the clearance 22 into the annular channel 24 passes from this annular channel through suitable ports 25 and engages the shoulder 26 formed on the bore of the valve 5. The pressure fluid acting against the shoulder 26 co-operates with atmospheric pressure acting against the inner transverse wall 27 of the bore of the valve 5 and with the live pressure acting on the pressure surface formed by the channel 18 and the outer face 19 of the valve to hold the valve 5 down or seated against the valve seat 20.

When the piston 3 passes the exhaust port 28 on its upward or rearward movement, the pressure in the channel 18, in the valve chest against the face 19, and against the shoulder 26 is relieved and the pressure against the pressure area 30 formed on the under or forward side of the valve 5 is increased by compression from the cylinder 2 caused by the rearward movement of the piston 3. The compression from the cylinder 2 acting upon the relatively large pressure area 30 plus the pressure of the pressure fluid in the channel 21 and in the channel 31 formed in the cylinder move or draw the valve 5 rearwardly against the valve seat 32 and cut off the flow of air under pressure or live pressure air to the forward end of the cylinder 2. The live air or air under pressure enters the annular channels 21 and 31 through the ports 33 formed in the valve 5. When the valve 5 is moved to cut-

off the flow of live air pressure to the forward end of the cylinder and after the piston 3 has closed the exhaust port 28, during its forward stroke, the flange 26 will be subjected to compression from the cylinder through the ports 25.

The ports 17 in the valve which opens into the annular channel 18, in the rearward face of the valve are either larger in area or greater in number so as to provide a larger open area to deliver pressure into the channel 18 than is provided by the ports 33 for delivering air under pressure to the channel 21, thereby providing differential pressure inlets to the pressure area on the opposite sides or faces of the valve 5.

The above operation is repeated on each cycle of operation of the percussive tool.

The inner transverse surface 27 which is opposed to the pressure area 30 is subjected to atmospheric pressure by means of the bore 34 formed in the stem 23 and the plurality of transverse ports 35 which communicate with the bore 34 and with atmosphere.

It will be understood that the invention is not to be limited to the specific construction or arrangement of parts shown but that they may be widely modified within the invention defined by the claims.

What is claimed is:

1. In a percussive tool, the combination of a cylinder having a piston chamber therein, a piston in said chamber, an exhaust port in the cylinder, a valve chest having a valve chamber and a pressure fluid inlet therein, inlet passages leading from the valve chamber to the piston chamber, a valve in said chamber comprising a body having opposed annular channels in its opposite faces, said valve provided with a plurality of transverse ports opening into said pressure inlet to supply pressure fluid to said channels and opposite faces for throwing the valve, an actuating surface on one end of said valve exposed to compression from piston chamber for assisting in throwing the valve, said valve provided with a bore formed actuating surface opposed to said first actuating surface, a stem extending into said bore and provided with a port opening to atmosphere to subject said bore formed actuating surface to atmospheric pressure, a flange on said valve and extending into said bore, said stem provided with ports open to compression from the cylinder to subject one surface of said flange to compression from the cylinder during one period of operation of the valve and to subject the flange to live air pressure during another period of operation of the valve.

2. In a percussive tool, the combination of a cylinder having a piston chamber therein, a piston in said chamber, an exhaust port in the cylinder, a valve chest having a valve chamber and a pressure fluid inlet therein, inlet passages leading from the valve chamber to the piston chamber, a valve in said chamber comprising a body

having opposed annular channels in its opposite faces, said valve provided with a plurality of transverse ports opening into said pressure inlet to supply pressure fluid to said channels and opposite faces for throwing the valve, an actuating surface on one end of said valve exposed to compression from piston chamber for assisting in throwing the valve, said valve provided with a bore formed actuating surface opposed to said first actuating surface, a stem extending into said bore and provided with a port opening to atmosphere to subject said bore formed actuating surface to atmospheric pressure, a flange on said valve and extending into said bore, said stem provided with ports open to compression from the cylinder to subject one surface of said flange to compression from the cylinder during one period of operation of the valve and to subject the flange to live air pressure during another period of operation of the valve, and a clearance between a part of said stem and valve chest to supply pressure fluid to the forward end of the cylinder.

3. In a percussive tool, the combination of a back head assembly a cylinder having a piston chamber therein, a piston in said chamber, an exhaust port in the cylinder, a valve chest in said back head assembly and having a valve chamber and a pressure fluid inlet therein, inlet passages leading from the valve chamber to the piston chamber, a valve in said chamber and having a bore therein, a flange on said valve extending into said bore, a passage in said back head assembly open to atmosphere and opening into said valve bore, and ports and passages in said cylinder and back head assembly whereby one side of said flange will be intermittently exposed to pressure fluid and the other side of the flange will be constantly exposed to atmospheric pressure for assisting in throwing the valve.

4. In a percussive tool, the combination of a cylinder having a piston chamber therein, a piston in said chamber, an exhaust port in the cylinder, a valve chest having a valve chamber and a pressure fluid inlet therein, inlet passages leading from the valve chamber to the piston chamber, a valve in said valve chamber comprising a body having an axial bore, said valve and valve chest provided with ports and areas for throwing the valve, a flange on the valve extending into said bore, a stem extending into said bore and provided with a port opening to atmosphere to subject one side of said flange to atmospheric pressure, said stem provided with ports open to compression from the cylinder to subject the opposite face of said flange to compression from the cylinder during one period of operation of the valve and to subject the flange to live air pressure during another period of operation of the valve.

HERMAN J. SCHORLE,
WILLIAM A. SMITH, JR.