

S. HAWVER.
FOLDING BED.

No. 523,983.

Patented Aug. 7, 1894.

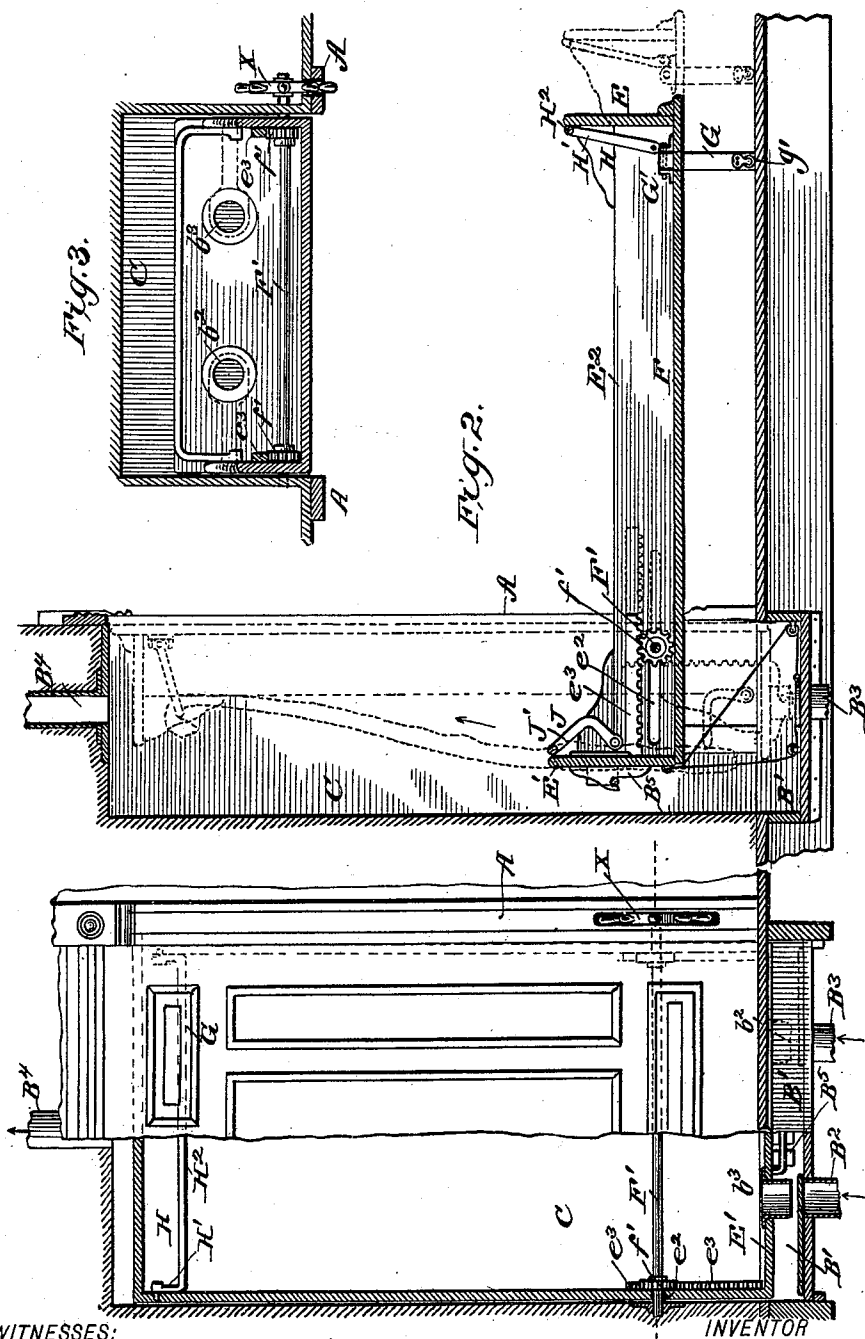

WITNESSES:
Fred G. Deterich
P. B. Turpin.

Fig. 1.

INVENTOR
Samuel Hawver
 BY *Munn & Co.*
 ATTORNEYS.

S. HAWVER.
FOLDING BED.

No. 523,983.

Patented Aug. 7, 1894.

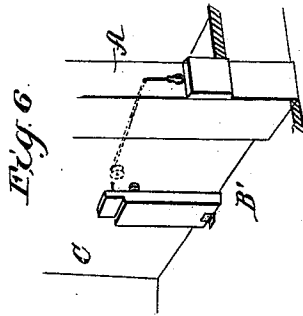

Fig. 6.

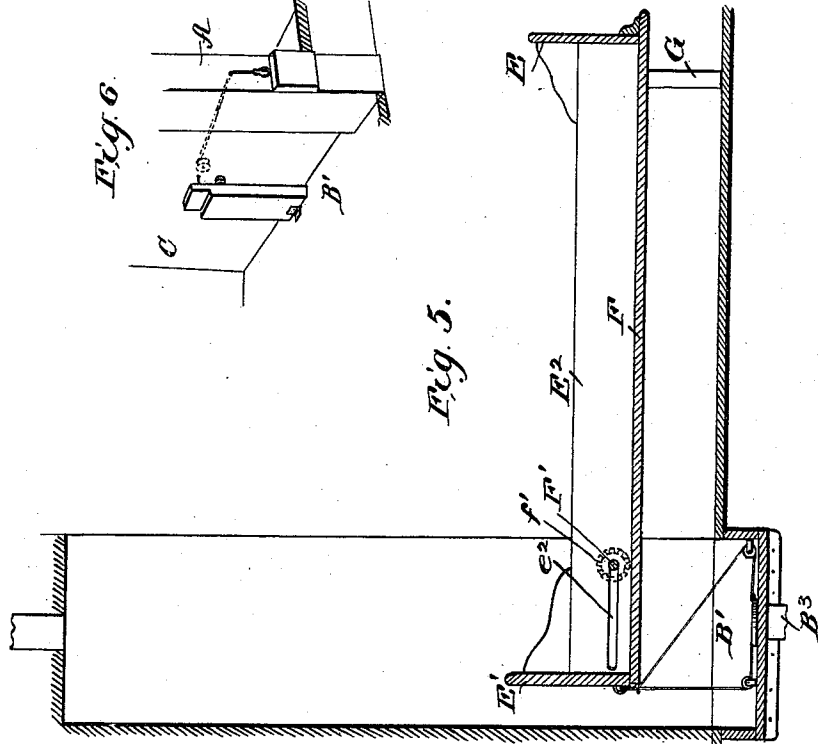

Fig. 5.

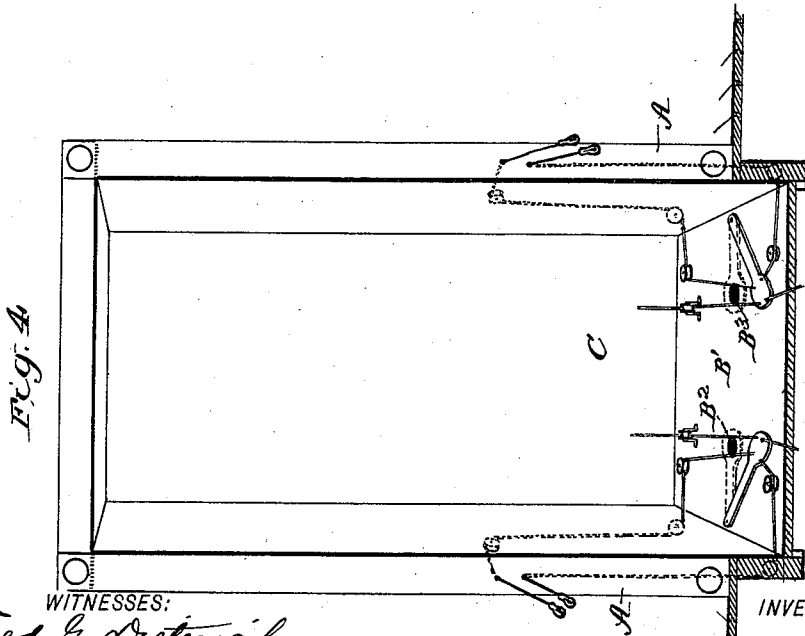

Fig. 4.

WITNESSES:

Fred G. Dretterich
P. B. Juppier.

INVENTOR

Samuel Hawver.
BY *Munn & Co.*
ATTORNEYS.

UNITED STATES PATENT OFFICE.

SAMUEL HAWVER, OF UNIVERSITY, CALIFORNIA.

FOLDING BED.

SPECIFICATION forming part of Letters Patent No. 523,983, dated August 7, 1894.

Application filed December 12, 1892. Serial No. 454,954. (No model.)

To all whom it may concern:

Be it known that I, SAMUEL HAWVER, a citizen of the United States, residing at University, Los Angeles county, State of California, have invented a new Folding Bed, of which the following is a specification.

My invention relates to improvements in folding beds.

The objects of my improvements are, first, to obtain a perfectly ventilated folding bed, a bed that may be warmed at will with the least outlay of labor or expense, I therefore place my bed in a recess in the wall of the house—thereby bringing it in right relations to the building to accomplish my object; second, to remove the bed entirely from the room during the day; third, by placing it in the wall it may be built in with the house, thereby becoming a permanent fixture; thus obviating the necessity of moving them from house to house; fourth, to furnish a bed that would permit the occupant to sleep with his head out of the cold currents along the wall, by placing the head at or near the center of the room; at the same time just as practical for sleeping with the head next to the wall; fifth, to produce a thoroughly practical, healthy bed at a minimum cost. I attain these objects in the manner illustrated in the accompanying drawings, in which—

Figure 1, is a front view partly in section of the bed folded in a recess in the wall out of use for the day. Fig. 2, represents a side sectional view; the dotted vertical lines show the position of the bed during the day, the solid vertical lines marking the recess. The horizontal solid lines in Fig. 2 show the bed folded down for use. The dotted lines at the right hand of the horizontal lines in Fig. 2 suggest the position of the bed when brought out from the recess. Fig. 3, shows a sectional view of the foot end of the bed (or in some instances it may be the head end); I shall, however, in my detail specification treat it wholly as the foot end. Fig. 4 is a face view of the wall recess showing the valves in place. Fig. 5 is a vertical section drawn through the bed and recess, and Fig. 6 is a detail view.

Similar letters refer to similar parts throughout the several figures.

My bed is shown as formed with the bottom F, outer end board E, inner head board

E' and side rails E², the latter being slotted at e² longitudinally for the cross shaft F' and provided adjacent to said slots with racks e³ to be meshed by pinions f' on said shaft. The shaft F' is journaled to the support which is shown as consisting of the wall of the building, and has a hand wheel X by which it may be conveniently turned. By turning this shaft the bed when lowered may be adjusted from the full line position Fig. 2 out to the outer dotted position same figure.

In supporting the outer end of the bed I employ the legs G which are pivoted at G' to the bed bottom F and swing laterally so that when the bed is closed up said legs may be turned in to form panels or parts of panels as shown in Fig. 1 and yet will drop by gravity when the bed is opened to the desired position. These legs have at their lower ends rollers g' journaled properly to roll when the bed is adjusted out and in as before described.

Adjacent to the outer end board E I support a clothes holder H which is in the nature of a bail having its arms H' pivoted to the bed and its cross bar H² extended across the same so that said cross bar may be turned against the end board E when the bed is lowered and in use or may be turned down over and against the bed clothes as shown in the upper dotted lines to hold the clothes to the bed as desired.

At the opposite end of the bed I provide a holder J whose purpose is to hold the bed clothes out from the mattress when the bed is folded to permit the circulation of air in between the bed clothes and mattress. This holder J is similar to the holder H except that its arms J' are bent to L shape forming a flat portion to rest against the bed frame and enable the cross bar to hold the clothes as shown in dotted lines Fig. 2.

In the inner end board E' are provided two flues b² and b² which in the folded adjustment of the bed register with inlet flues B³ B³ presently described.

In the wall or partition is formed a recess C sufficiently deep and high to receive the bed the bottom F of which forms a paneled front for said recess when adjusted to the position shown in Fig. 1, it fitting snugly between the side moldings A as shown. This recess C is depressed at B' slightly below the

level of the floor B as shown in Fig. 2. Flues B² and B³ lead into the recess and a flue B⁴ leads therefrom. One of the inlet flues admits fresh outside air while the other admits warm air which may be supplied by a furnace, stove, gas jet, lamp or other heater. Valves are provided by which to regulate and stop the flow of hot or cold air. These valves are arranged to be automatically opened when the bed is folded into the recess and to be closed when the bed is opened but they may also be opened and shut by hand as desired. By this construction the bed can be thoroughly aired in the day time without taking up any floor space and can be conveniently heated at night before using.

It will be preferred to provide an additional air controlling valve so that in case the outside air is too damp the house keeper can close the air inlet without disturbing the bed. The outlet flue from the wall recess may open into a chimney or may discharge between the studding or be otherwise provided with an exit.

The bed is balanced with counterweights B⁵ which may be arranged as shown in Fig. 1 or otherwise as desired.

In operation the bed may be raised out of the room and form a neat paneled or mirrored section in one side thereof or may be lowered on the shaft F' as an axis and then run out by means of the shaft and pinions and rack as described.

In Fig. 6 I show a spring actuated safety lock for fastening the bed in place when such bed is folded to position for use.

Having thus described my invention, what I claim, and desire to secure by Letters Patent, is—

1. The combination substantially as described of the wall having a ventilating flue or opening, the valve controlling said opening, the folding bed and connections whereby the movements of the bed will effect the opening and closing of the valve, substantially as set forth.

2. The combination substantially as de-

scribed of the wall having a recess, the bed arranged to fold thereinto and flues in the bed and recess arranged to register when the bed is folded substantially as set forth.

3. The combination substantially as described of the wall having a recess flues communicating therewith, valves controlling said flues the bed arranged to fold into and out of said recess and connections between said valves and the bed whereby the movements of the bed will operate the valves all substantially as set forth.

4. The combination substantially as described of the wall having a recess, and flues communicating therewith the bed arranged to fold into and out of said recess and automatically operated valves by which to control said flues by the opening and closing of the bed substantially as set forth.

5. The combination of a cross shaft having a pinion, bearings for said shaft and the folding bed held to and movable longitudinally upon said shaft and having a rack meshed with the wheel of said shaft, substantially as set forth.

6. A folding bed having its side rails provided with longitudinal slots and provided adjacent to said slots with racks the shaft passed through said slots and having pinions meshing with the racks and bearings for said shaft substantially as set forth.

7. A pivoted folding bed provided with a pivoted bail like clothes holder extended transversely across the bed and adapted to fit below and hold the covering or bed clothes out away from the bed, substantially as set forth.

8. A pivoted folding bed provided at its opposite ends with clothes holders one of which is adapted to hold the covering to the bed and the other to hold such covering out away from the bed substantially as set forth.

SAMUEL HAWVER.

Witnesses:

B. T. TILDEN,
C. J. LIPE.