



(86) **Date de dépôt PCT/PCT Filing Date:** 2012/02/10
 (87) **Date publication PCT/PCT Publication Date:** 2012/08/16
 (45) **Date de délivrance/Issue Date:** 2017/02/28
 (85) **Entrée phase nationale/National Entry:** 2013/07/25
 (86) **N° demande PCT/PCT Application No.:** US 2012/024747
 (87) **N° publication PCT/PCT Publication No.:** 2012/109606
 (30) **Priorité/Priority:** 2011/02/11 (US61/441,845)

(51) **Cl.Int./Int.Cl. A61B 17/12** (2006.01)

(72) **Inventeurs/Inventors:**
 BECKING, FRANK P., US;
 HALDEN, STERLING, US;
 DIECK, MARTIN S., US;
 DEBEER, NICHOLAS C., US;
 RVALACABA, TERESA, US;
 LUNDKVIST, ANDRE, US

(73) **Propriétaire/Owner:**
 COVIDIEN LP, US

(74) **Agent:** SMART & BIGGAR

(54) **Titre : DISPOSITIFS D'EMBOLISATION D'ANEVRISME A DEPLOIEMENT EN DEUX ETAPES**
 (54) **Title: TWO-STAGE DEPLOYMENT ANEURYSM EMBOLIZATION DEVICES**

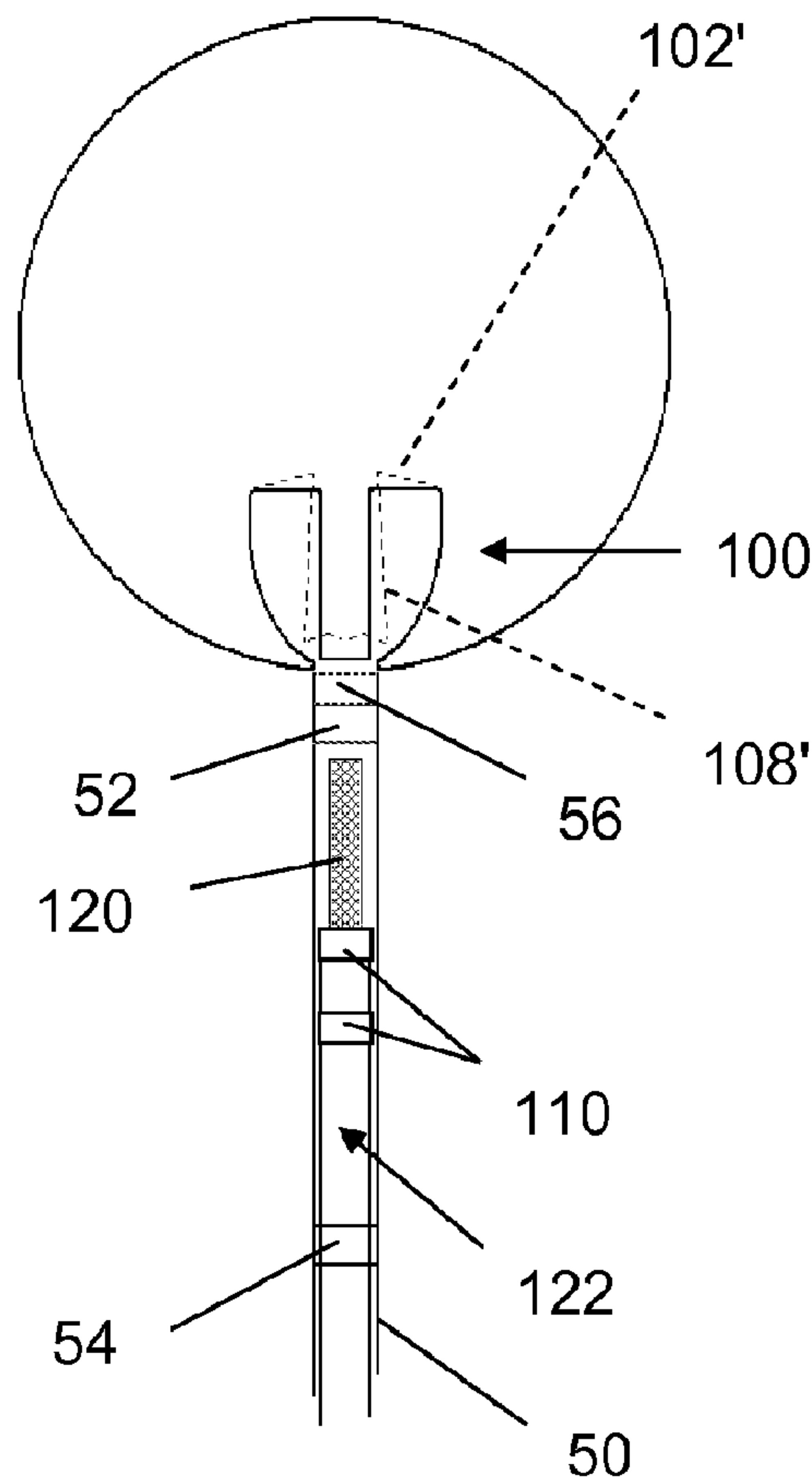

(57) **Abrégé/Abstract:**

Emboic implants, delivery systems and methods of manufacture and delivery are disclosed. The subject implants are deployed in two stages. If sized properly as observed in the first stage, they are deployed to the second stage and detached. If not sized

(57) Abrégé(suite)/Abstract(continued):

properly in/at the first stage, the implants are designed to be withdrawn and replaced with a more appropriately sized implant or another treatment option selected. Some of the implant configurations may be withdrawn even after the second stage deployment as well.

(12) INTERNATIONAL APPLICATION PUBLISHED UNDER THE PATENT COOPERATION TREATY (PCT)

(19) World Intellectual Property
Organization
International Bureau(10) International Publication Number
WO 2012/109606 A1(43) International Publication Date
16 August 2012 (16.08.2012)(51) International Patent Classification:
A61B 17/12 (2006.01)(21) International Application Number:
PCT/US2012/024747(22) International Filing Date:
10 February 2012 (10.02.2012)

(25) Filing Language: English

(26) Publication Language: English

(30) Priority Data:
61/441,845 11 February 2011 (11.02.2011) US(71) Applicant (for all designated States except US): **NFOCUS NEUROMEDICAL, INC.** [US/US]; 2191 E. Bayshore Road, Palo Alto, CA 94303 (US).

(72) Inventors; and

(75) Inventors/Applicants (for US only): **BECKING, Frank, P.** [US/US]; P.O. Box 800, Palo Alto, CA 94302 (US). **HALDEN, Sterling** [US/US]; 985 Cherry Street, San Carlos, CA 94070 (US). **DIECK, Martin, S.** [US/US]; 235 Cherry Lane, Campbell, CA 95008 (US). **DEBEER, Nicholas, C.** [US/US]; 512 7th Street, Montara, CA 94037(US). **RVALACABA, Teresa** [US/US]; 2191 E. Bayshore Road, Palo Alto, CA 94303 (US). **LUNDKVIST, Andre** [US/US]; 2191 E. Bayshore Road, Palo Alto, CA 94303 (US).(74) Agent: **STIRRAT, Mark, A.**; Dickstein Shapiro LLP, 2049 Century Park East, Suite 700, Los Angeles, CA 90067-3109 (US).

(81) Designated States (unless otherwise indicated, for every kind of national protection available): AE, AG, AL, AM, AO, AT, AU, AZ, BA, BB, BG, BH, BR, BW, BY, BZ, CA, CH, CL, CN, CO, CR, CU, CZ, DE, DK, DM, DO, DZ, EC, EE, EG, ES, FI, GB, GD, GE, GH, GM, GT, HN, HR, HU, ID, IL, IN, IS, JP, KE, KG, KM, KN, KP, KR, KZ, LA, LC, LK, LR, LS, LT, LU, LY, MA, MD, ME, MG, MK, MN, MW, MX, MY, MZ, NA, NG, NI, NO, NZ, OM, PE, PG, PH, PL, PT, QA, RO, RS, RU, RW, SC, SD, SE, SG, SK, SL, SM, ST, SV, SY, TH, TJ, TM, TN, TR, TT, TZ, UA, UG, US, UZ, VC, VN, ZA, ZM, ZW.

(84) Designated States (unless otherwise indicated, for every kind of regional protection available): ARIPO (BW, GH, GM, KE, LR, LS, MW, MZ, NA, RW, SD, SL, SZ, TZ, UG, ZM, ZW), Eurasian (AM, AZ, BY, KG, KZ, MD, RU,

[Continued on next page]

(54) Title: TWO-STAGE DEPLOYMENT ANEURYSM EMBOLIZATION DEVICES

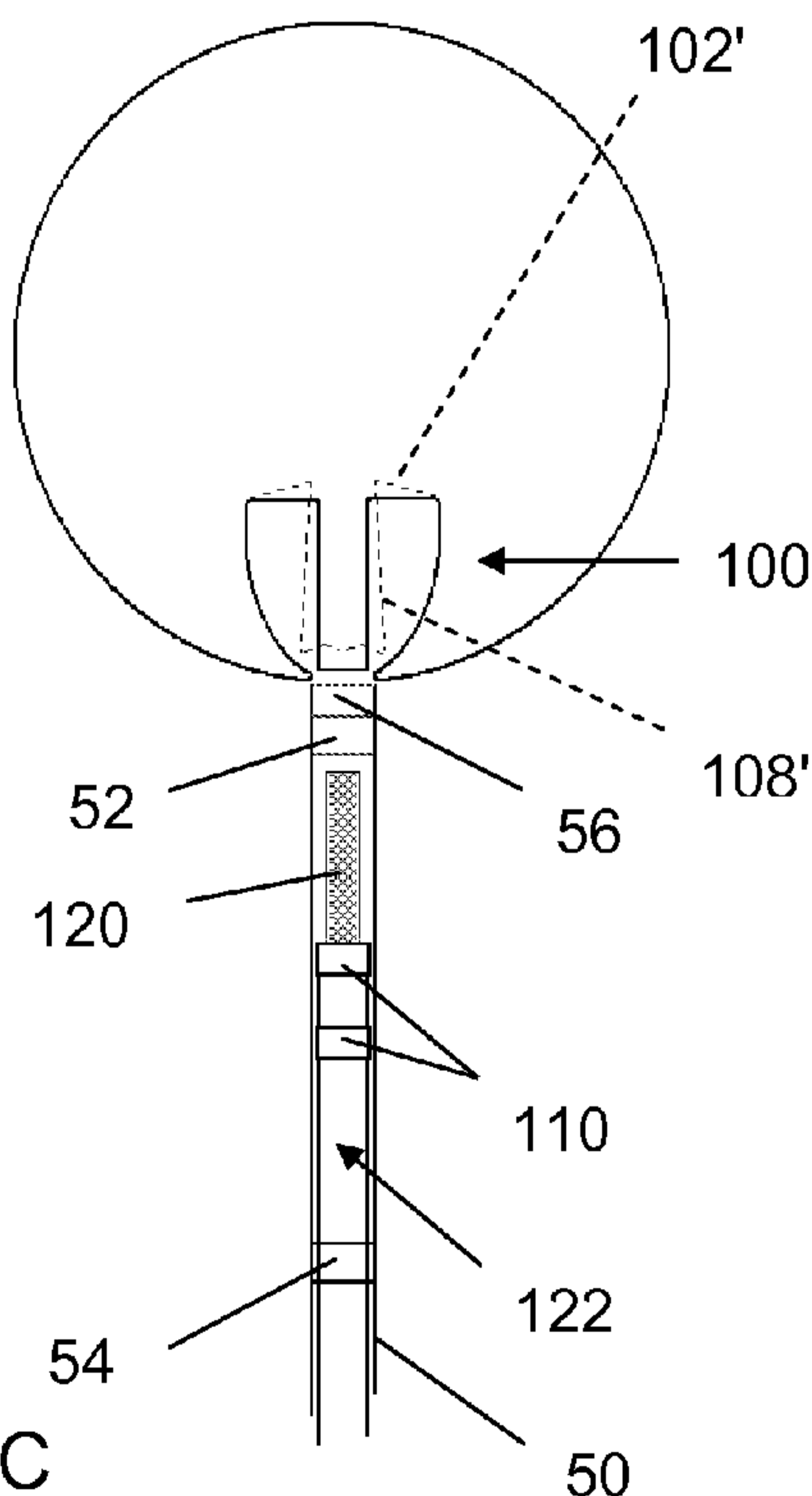

Fig. 6C

(57) Abstract: Embolic implants, delivery systems and methods of manufacture and delivery are disclosed. The subject implants are deployed in two stages. If sized properly as observed in the first stage, they are deployed to the second stage and detached. If not sized properly in/at the first stage, the implants are designed to be withdrawn and replaced with a more appropriately sized implant or another treatment option selected. Some of the implant configurations may be withdrawn even after the second stage deployment as well.

WO 2012/109606 A1 

TJ, TM), European (AL, AT, BE, BG, CH, CY, CZ, DE, DK, EE, ES, FI, FR, GB, GR, HR, HU, IE, IS, IT, LT, LU, LV, MC, MK, MT, NL, NO, PL, PT, RO, RS, SE, SI, SK, SM, TR), OAPI (BF, BJ, CF, CG, CI, CM, GA, GN, GQ, GW, ML, MR, NE, SN, TD, TG).

Published:

— *with international search report (Art. 21(3))*

Two-Stage Deployment Aneurysm Embolization Devices

RELATED APPLICATIONS

[0001] The present filing claims the benefit of US Patent Application Serial No. 61/441,845 filed February 11, 2010.

BACKGROUND

[0001] Numerous companies have pursued ball-type embolization devices for aneurysm treatment. Many of these, including the Nfocus LUNA device and other embodiments disclosed in commonly-owned patent applications are designed to be sized to fit a given aneurysm when the implant is fully deployed outside a delivery catheter. The same is true for the braid-ball implants disclosed and produced by Sequent Medical, Inc.

[0002] At least with the LUNA device, if size as visualized upon deployment (under active x-ray- i.e., "medical imaging") is acceptable to a physician, the implant is detached. If not, the device is retrieved and exchanged for a more appropriate size. No example of devices designed for intra-aneurysmal treatment are known in which confirmation of final sizing is accomplished under medical imaging where the implant is deployed only up to a pre-selected or identified point. Certainly, embolization coils are often partially deployed within an aneurysm and visualized to determine if their size and/or configuration is acceptable before further advancing the same and effecting release. However, these are not deployed to a specified point as marked on the delivery system for making a size check.

SUMMARY

[0003] Generally, braid-balls for aneurysm or other embolization through blood flow disruption and thrombus formation are described. More specifically, variations of the invention concern a subject hub region architecture that may be employed in a single-layer braid ball implant or a double-layer "LUNA" type (i.e., folded-over/flat) implant architecture.

[0004] In use, the bulb of the subject implant is deployed in an aneurysm with the estimated final position of the proximal end visualized by aligning a catheter marker with the device proximal end. The implant end may include a band or otherwise (such as by

welding) serve as a hub to the braid from which the implant is constructed. Other options as described further below are disclosed as well.

- [0005]** Regardless, if the first stage/bulb "fits", then the adjacent retracted hub region is fully deployed (i.e., the second stage is deployed) and the implant is released from its pusher. The position of the catheter shaft marker and shape of the (first) sizing stage of the implant may be selected from a number of options as shown and described, as well as others.
- [0006]** The shape in the hub region is preferably configured to provide force for self-actuation upon catheter exit. One advantageous configuration is substantially spherical. Another contemplated shape is defined by two conical bodies meeting around a common base. When inset in a more curvilinear (heart-shaped) in cross section, the deployed hub can provide additional blood flow satiation zone(s) within the implant.
- [0007]** In any case, the inset is provided such that it can retract even when the implant is compressed to fit a high aspect ratio aneurysm. As demonstrated, the implant is operable in a pocket simulating an aneurysm with a dome-to-width ratio of about 2:1. Based on the implant configuration, higher ratios will be possible as well.
- [0008]** The exemplary embodiment demonstrating such activity employs a small spherical inset region. The inset region was defined over a spherical ball about 3mm in diameter, for an implant between at least about 6-7 mm in gross outside diameter. Thus, the nested inset region can fully expand even within the outer bulb when partially compressed. When using the double-cone shape for the inset region, the additional stored energy available at the medial crease can be of further assistance driving inset shape recovery. Moreover, the conical taper can provide improved clearance for full expansion of the inset form in cases where the outer body or bulb of the implant is further compressed.
- [0009]** The distal/terminal end of the implant and any associated proximal hub/band may be positioned at the periphery of the bulb of the implant when fully deployed, or more inset in varying degrees. When employed in a "LUNA" folded-flat configuration, the distal marker of the implant is internal and a tether extends to the proximal hub of the device. In a one-layer implementation (i.e., a configuration that presents one layer at the distal end of the implant with the option of more at a proximal side depending on inset shape configuration) the distal marker be provided by a radiopaque material (e.g., Pt) band capturing the braid. As to the proximal side of either such device, it may comprise a

radiopaque band capturing the braid. As discussed in US Patent Application No. 2011/0319926 (Becking, et al.) another option is to remove the band after the braid has been glued to create a composite hub construct.

- [0010]** In yet another variation, no such hub or band is provided at the proximal end of the braid defining the implant. Instead, a length of braid (between about 1 and about 2 mm long) is employed as a delivery system interface. Such a "tail" or sleeve of braid, when confined within a catheter is able to firmly grip/interlock with a complementary delivery system surface. In such a system, the delivery system surface is also advantageously covered or constructed of braid of a similar wire size and configuration to promote interlocking. Once the implant is free of the catheter, the (formerly) confined sleeve of braid defining the implant tail opens to permit the inner delivery system pusher member to be pulled free.
- [0011]** The forming method for a LUNA-style hidden hub implant is detailed herein in two heatsetting stages. Stage 1 produces a double-layer "folded-flat" implant preform with a columnar inset. Stage 2 changes the shape of the inset into a spherical volume. In the second forming and heatsetting procedure, a proximal suture tie may be employed in defining a second folded-flat region like that at the distal side as formed in Stage 1. The second heatsetting cycle may also be employed to modify the shape of the outer bulb. For example, while retaining the "folded-flat" distal bend(s), the gross shape of the bulb may be compressed from a substantially cylindrical shape to a more squat or flattened "M&M" shape (e.g., ellipsoidal). So-shaped, greater radial force is available for aneurysm fit and/or a greater range of treatment sites made available. Further reference to heatsetting methodology and delivery systems as may be applied to the present invention are presented in US Patent Application Serial No. 12/465,475 and PCT/US2009/041313 and US Patent Application Serial No. 12/942,209 and PCT/US2010/56051.
- [0012]** Other manufacture techniques are applicable as well. For instance, a selective heat treatment approach is contemplated in which a portion of the implant performing being shaped is set over a ferromagnetic material (e.g., 304 magnetic stainless steel alloy) and is heated through induction utilizing a radio-frequency (RF) field. Such an approach strictly localizes the heat treatment to areas in contact with the induction-heated element. To insure that no other material is significantly heat-affected, such activity may be conducted under the flow of coolant such as Nitrogen or Argon gas

or some other medium. In any case, such an approach may be advantageously used in the "Stage 2" operation described above for re-shaping the inset region, without applying a second heat treat to the remainder of the implant preform.

[0013] The body of the subject implants may be constructed of NiTi alloy that is superelastic at human body temperature. Advantageously, the wire is in the size range of 0.0008 to 0.0013 inches, although it may be larger or smaller. It may be etched pre- and/or post-heat treatment using AYA solution or by such processes employed by service providers including NDC, Inc. Binary Nitinol alloy may be employed, or the alloy may include Au, Pt, W, Ir, Pd, alloys thereof or another dense element to improve radiopacity. Another approach to improving radiopacity contemplates using a plurality of such wires or ribbons intermixed when braiding with Nitinol. Otherwise, Pt core Nitinol Drawn Filled Tube (DFT) may be employed or other means.

[0014] The braid matrix is particularly effective in promoting thrombosis in order to embolize an aneurysm as its density increases. For a given catheter crossing profile, a certain maximum braid configuration is possible. For example, "folded-flat" implants as further described herein that are intended to track to the neurovasculature through commercially available 3Fr/0.027 inch catheters (such as the REBAR or MARKSMAN) may be constructed from a 72x0.001" braid configuration (as originally provided or etched thereto) or 96x0.0009" braid (ditto) configuration. In single layer implant architectures, 144-end braid configurations are feasible with similar crossing profile with wire size in the range of about 0.008 to about 0.0011 inches in diameter. Still, it is to be noted that higher end count braid (e.g., 192 or 288) can be employed in the subject invention as can other braid end multiples/configurations. Likewise, it is possible to construct braided implants indented for 0.021 inch catheter compatibility. These may advantageously use two layers of 48x0.001" braid or higher "end" multiple counts in thinner wire/filament or single-layer 72 or 96 end braid selections, etc.

[0014a] According to an aspect, there is provided an aneurysm treatment system comprising: a catheter with a distal marker and a proximal reference marker; an implant pusher; and an implant comprising a bulbous portion and a tail portion, the tail portion adapted to be received in a linear configuration within the catheter for delivery and to define an inset within the bulbous portion when delivered, wherein at least one of the pusher and the implant comprises a marker that, when aligned with the proximal

reference marker, positions at least the bulbous portion of the implant in a first stage indicative of a final deployed height of the implant in a second stage.

[0014b] According to another aspect, there is provided a method of implant manufacture comprising: forming an intermediate stage implant preform with a bulbous portion and an inset cylindrical section; heatsetting the intermediate stage implant preform; modifying a shape of the intermediate stage implant preform whereby the inset cylindrical section is changed into another shape to produce a final stage implant preform; heatsetting the final stage implant preform; attaching the implant to an implant pusher; and inserting the implant into a catheter having a distal marker and a proximal reference marker, such that a tail portion of the implant received in a linear configuration within the catheter for delivery defines an inset within a bulbous portion of the implant when delivered; wherein at least one of the pusher or the implant comprises a marker that, when aligned with the proximal reference marker, positions the bulbous portion of the implant in the intermediate stage indicative of a final deployed height of the implant in the final stage.

[0015] In any case, the subject inventions include the devices, kits in which they are included, methods of use and methods of manufacture. More detailed discussion is presented in connection with the figures below.

BRIEF DESCRIPTION OF THE FIGURES

[0016] The figures provided herein are not necessarily drawn to scale, with some components and features exaggerated for clarity. Variations of the invention from the embodiments pictured are contemplated. Accordingly, depiction of aspects and elements of the invention in the figures are not intended to limit the scope of the invention.

[0017] Fig. 1 illustrates a variation of the subject implant deployed in an side-wall aneurysm model; Figs. 2A and 2B and Figs. 3A and 3B diagrammatically illustrate an implant in use with coordinated catheter systems at different first and second stages of implant deployment, respectively; Figs. 4A-4D illustrate the implant construction from Fig. 1 visualized through a clear catheter in the stages of deployment represented in Figs. 2A-3B; Figs. 5A-5F illustrate inset configuration variations; Figs. 6A-6C illustrate deployment of an implant with a hubless delivery system interface employing yet another inset configuration; Figs. 7A-7D illustrate stages of implant production; and Fig. 8 is a flowchart showing various implant manufacture options.

DETAILED DESCRIPTION

[0018] Various exemplary embodiments of the inventive aspects are described below. Reference is made to these examples in a non-limiting sense. They are provided to illustrate more broadly applicable aspects of the subject inventions. Various changes may be made to the subject matter described.

[0019] ANEURYSM EMBOLIZATION SYSTEMS

[0020] The embodiments described herein are specifically designed so that, when deployed to a given stage within an aneurysm, the size of this stage is representative of the final size and configuration of the implant upon final deployment with the delivery system. Several advantages can be achieved in conjunction with such a system. One such advantage involves the opportunity to minimize delivery profile and/or complexity given the unique implant/delivery system interaction enabled. Another advantage involves the opportunity to provide larger implant sizes for a given delivery profile. Still another set of advantages involves the ease of expanded implant recapture, together with associated procedural and patient safety advantages. All told, aspects of the present invention (alone and/or in combination with one another) provide for a new and useful system for neurovascular aneurysm treatment or for treating other vascular, pocket-type or luminal defects.

[0021] Fig. 1 shows an implant 10 delivered according to the subject methodology as deployed in an side-wall aneurysm model 2. The model includes a parent vessel 4 and aneurysm fundus 6 filled by the implant 10. The implant is delivered in association (preferably via a detachable association vs. simple abutment) with a pusher 20. The implant comprise an outer bulb 12 and a substantially spherical inset region 14. A dense and complex structure is thus presented to the direction of blood flow (as indicated by arrows) to help promote blood thrombosis via disruption of its flow. Markers are optionally present at proximal and distal extents 16, 18 of the implant.

[0022] Figs. 2A and 2B and Figs. 3A and 3B diagrammatically illustrate the implant in use with coordinated catheter systems. Figs 2A and 2B illustrate one optional approach to staged deployment; Figs. 3A and 3B illustrate another. All of these figures illustrate a generic distal implant architecture 30 in which a distal marker 32 diagrammatically pictured. In each view, the implant includes a proximal hub/marker band 34 operating as an interface region to an (optionally detachable) pusher 40. The hub and pusher may be

connected by a mechanical detachment interface as described in the above-referenced patent applications, an electrolytically-severable joint, a meltable polymer filament, etc. In any case, the pusher is shown within the end of a microcatheter 50. The microcatheter includes a distal marker 52 and a more proximal reference marker 54.

[0023] In Fig. 2A, the reference marker is set at a position such that when the implant proximal hub/marker 34 is aligned therewith the freed/expanded portion of the implant is deployed in a "teardrop" of approximately the same height of the finally deployed implant shape as shown in Figs. 2B and 3B. Likewise, the catheter reference marker shown 54' in Fig. 3A is positioned such that a "mushroom" shape with flats 36 is produced upon hub 34 alignment therewith. Again, this intermediate implant body shape is similarly sized to the finally delivered implant configuration.

[0024] As such, at either intermediate stage of delivery (i.e., in a system configured per Figs. 2A, 3A or related thereto) a physician can determine if the implant is the proper size selected for the aneurysm to be treated by visualizing the position of the distal marker 32 in/on the implant and the distal marker 52 of the catheter. If the distal marker of the catheter is positioned at the neck of the aneurysm when the implant is in the first/intermediate stage of delivery, then the physician is offered an indication (mid-procedure) that upon completion of implant deployment that the proximal surface of the implant will be likewise so-positioned, as desired. Thus, an aspect of the invention concerns a catheter with a marker system and an implant (or an implant pusher as further described below) that include radiopaque markers coordinated for a first "check" stage of deployment followed by a "final" release/released deployment stage.

[0025] Figs. 4A-4D illustrate the implant construction in stages of deployment visualized within a glass vial serving a second model 2'. The implant 30 is shown at various positions confined within a clear sheath 50' simulating a catheter. Proximal to a marker element 34 seen in each image is a coil-reinforced length 22 simulating a pusher. Fig. 4A illustrates the implant in a first stage of the deployment of bulbous portion with the catheter end at point A. In Fig. 4B, the full-size teardrop sizing-check shape has developed with the catheter end at point B. With little or no substantial change in height, the mushroom sizing shape is developed with the catheter end at point B'. As evident from movement of marker 34, however, the pusher has been advanced. Upon advancement of the pusher and marker 34 to its ultimate/final position before pusher detachment, the final implant shape is formed with no significant difference in the

position of the proximal face of the implant as evident by the alignment of the lead-line arrows.

[0026] Notably, all of the figures up to this point illustrate an inset region 14 configuration as shown in cross section per Fig. 5A. Likewise, Fig. 5A illustrates the manner in which the sizing of the inset region 14 accommodates different compression factors 30, 30' of the same implant ball or bulb. The relatively small(er) spherical inset configuration in Fig. 5A is advantageously formed as further described below. Moreover, it demonstrates robust recovery and actuation as pictured. However, other inset shapes or forms offer further advantages and options as described below.

[0027] For example, Fig. 5B illustrates an inset 60 that is "heart shaped" in cross section. Such an inset offers additional clearance for bulb compression along a conical proximal section 62. Yet, the curve 64 to the distal section facilitates recapture of the device even after complete exit of extension 66 and hub 34 from the delivery catheter. By way of contrast, a double-conical shaped inset 70 as shown in Fig. 5C may "lock" with the catheter at the deeply inset "V" junction 72. Yet, the double-cone shape may be desirable because the increased number of sharp bends or transitions within the profile can help drive predictable shape recovery and increase resistance to radial compression within the proximal portion of the device.

[0028] Fig. 5D illustrates a second species of conical inset 74. In this variation, the two cones are adjacent, each with its own base 76, 76' instead one that is conjoined. Further, Fig. 5D illustrates the manner in which any "tail" or extension section of the braid connecting to the hub 34 can be made short or essentially eliminated as compared to the previous variations. Moreover, the upper and lower cones are set at different angles so as to close the proximal end of the device at 78. Naturally, the previous inset variations can receive similar treatment as well.

[0029] Fig. 5E illustrates an approach in which the entry/exit port of the hub 34' is inverted. Thus, recapture into a catheter requires a 180 degree bend form at the braid/hub junction. It will track the same way in the catheter for deployment. Such a feature may limit catheter downsizing. However, this feature can be accommodated by utilizing finer wire (e.g., 0.0008 inch diameter or less) able to bend in a tighter radius than heavier wire.

[0030] Again, the length or position of the inset extension 82 can be varied. For example, it may be desirable to extend it such that the position of the hub marker 34'

appears in roughly the center of implant 30 when uncompressed as illustrated in dashed line. Such an approach may be desirable when intending to fill a cavity with multiple numbers (e.g., in a multi-ball treatment approach to giant aneurysm) of the same implant that are allowed to fully expand, rather than form-fitting a single implant to fill an aneurysm. In which case, the hub can serve as a single, centrally-located marker.

[0031] Next, Fig. 5F illustrates an inset 90 that includes no hub and/or marker arrangement. Instead, this inset is configured especially for use with a delivery system as illustrated in Figs. 6A-6C. Its shape is set to open when uncompressed by a catheter at bulb 92, while offering additional compression force at bends 94 for delivery system securement (via increased linear pressure) when the shape is compressed within the delivery catheter.

[0032] With respect to Figs. 6A-6C, these illustrate an implant 30 with a urn or vase-shaped inset 100 as shown deployed/developed in Figs. 6B and 6C. Such an inset offers advantageous proximal-side clearance, with a flat top 102 reducing inset height, and a distal crease 104 storing energy upon compression to drive shape recovery upon catheter release.

[0033] More generally, Fig. 6A illustrates implant 30 with bulb 12 outside of a delivery catheter 50 and implant tail 106 (before it transforms into the inset shape 100) still located therein. An interface segment 108 of the tail surrounds a textured (optionally by matching braid) retention section 120 of a pusher 122.

[0034] The whole length of the pusher may comprise metal braid which is encased/co-extruded by Polyimide with the distal section ablated from the braid. Components for such construction and ablation services are available from Microlumen, Inc. Tapered flex can be designed into the shaft by further selective ablation and/or including a taper-ground wire (floating or bonded) within a lumen of the pusher construction.

[0035] The delivery microcatheter includes a distal soft tip 56 and distal marker 52. A proximal reference marker 54 on the catheter is shown located between a pair of reference markers 110 on pusher 122. So long as the catheter holds the implant

interface section compressed to the pusher retention section, the implant can be retrieved.

[0036] However, upon full deployment as shown in Fig. 6B, the interlocking interface between the implant and pusher is lost. At this point, pusher 122 may be withdrawn as shown in Fig. 6C and the catheter withdrawn as well. As positioned, the distal end of the catheter continues to mark the proximal position of the implant as the pusher is withdrawn, with only a small gap.

[0037] Also noteworthy is manner in which the inset may be shaped to facilitate implant release. As illustrated by dashed line of features 102' and 108' in Fig. 6C, the inset may be shaped to specifically pull-away from the pusher retention section upon exit from the delivery microcatheter.

[0038] IMPLANT MANUFACTURE

[0039] As referenced above, the subject implant architecture may be employed in a single layer braid ball implant or a double-layer LUNA type (folded-over/flat) approach. Figs 7A-7D illustrate aspects of manufacture in the latter case. Further details may be appreciated in reference to the applications Serial Nos. 12/465,475 and 12/942,209 and PCT/US2009/041313 and PCT/US2010/56051.

[0040] As illustrated in Fig. 7A, a "Stage 1" or "Intermediate" state implant preform 200 can be shaped and heatset in association with internal heatsetting tooling element or form 210 and such other elements as described in the referenced descriptions with the addition of a deep columnar inset 202 formed with sleeve 212. With a close-fit relation between the layers of braid 230, 232 and the form elements 210, 212 tight radius bends are set at the turns 224 as indicated.

[0041] Once freed of the form elements as shown in Fig. 7B, preform 202 is better visualized as including a generally bulbous portion 204 along with inset 202 and extension or tail region 206. The depth "D" of the inset is coordinated to facilitate its acceptance of a secondary internal form 214 as shown in Fig. 7C. With a tie 216 to hold it in place, the extent of the bulb 204 (shown as inverted sections 204' Fig. 7C) can be reversed or "flipped" back into shape as shown in Fig. 7D.

[0042] With a mandrel 218 secured (e.g., by a metal tie 220) in position relative to form 214, a shoulder 222 can be used to compress a proximal fold 234 in the device, and a table or flat 222 can be used to compress the bulb against table element 224 into a

modified shape (in this case more "squat" or ellipsoidal in cross-section) in a second heatsetting step to define a "Stage 2" of "Final" shape preform 200'.

[0043] Such a process flow path is illustrated as the left path in the flowchart of Fig. 8. Specifically, after forming the native braid (previously heatset or not) from which the implant is constructed over and within mandrel/form pieces at 300, the body is heatset at 302. Freed from the first set of heatsetting fixtures, it is optionally reshaped/reformed at 304, followed by a second overall heatsetting procedure 306. Finally, at 308, further processing such as optionally hubbing with marker bands, installing other marker features, hub welding, etc. is performed and then loading onto any optional delivery system pusher, onto packaging and sterilization as is common.

[0044] As an alternate flow path, after the first heatsetting and second shaping, only the inset is heatset at 306'. This can be accomplished as described above using a ferromagnetic material and induction field to concentrate heat for setting the shape of the braid in contact with element 214, for example.

[0045] Generally when the braid comprises Nitinol, any such heatsetting is accomplished between 500-550 °C for a period up to about 5 minutes. Such heating may be followed by quenching in water or be otherwise performed.

[0046] Regardless, it is further contemplated that the entire shaping of the implant may occur in one more complex cycle 310 in which each of the bulb and inset portions of the implant are formed simultaneously over a more complex set of nested forms. Such an approach may be especially viable when the implant only comprises a single layer of braid instead of also including a folded-flat distal section.

[0047] **VARIATIONS**

[0048] The subject methods may include each of the physician activities associated with implant positioning and release. As such, methodology implicit to the positioning and deployment of an implant device forms part of the invention. Such methodology may include placing an implant within a brain aneurysm, or at parent vessel targeted for occlusion, or other applications. In some methods, the various acts of implant introduction to an aneurysm or parent vessel are considered. More particularly, a number of methods according to the present invention involve the manner in which the delivery system operates in reaching a treatment site, for example. Other methods concern the manner in which the system is prepared for delivering an implant.

[0049] Also, it is contemplated that any optional feature of the inventive variations described may be set forth and claimed independently, or in combination with any one or

more of the features described herein. Reference to a singular item, includes the possibility that there is a plurality of the same items present. More specifically, as used herein and in the appended claims, the singular forms "a," "an," "said," and "the" include plural references unless specifically stated otherwise. In other words, use of the articles allow for "at least one" of the subject item in the description above as well as the claims below. It is further noted that the claims may be drafted to exclude any optional element. As such, this statement is intended to serve as antecedent basis for use of such exclusive terminology as "solely," "only" and the like in connection with the recitation of claim elements, or use of a "negative" limitation.

[0050] Without the use of such exclusive terminology, the term "comprising" in the claims shall allow for the inclusion of any additional element irrespective of whether a given number of elements are enumerated in the claim, or the addition of a feature could be regarded as transforming the nature of an element set forth in the claims. Except as specifically defined herein, all technical and scientific terms used herein are to be given as broad a commonly understood meaning as possible while maintaining claim validity.

[0051] The breadth of the present invention is not to be limited to the examples provided and/or the subject specification, but rather only by the scope of the claim language. Although the foregoing invention has been described in detail for purposes of clarity of understanding, it is contemplated that certain modifications may be practiced within the scope of the appended claims.

CLAIMS

1. An aneurysm treatment system comprising:
a catheter with a distal marker and a proximal reference marker;
an implant pusher; and
an implant comprising a bulbous portion and a tail portion, the tail portion adapted to be received in a linear configuration within the catheter for delivery and to define an inset within the bulbous portion when delivered,
wherein at least one of the pusher and the implant comprises a marker that, when aligned with the proximal reference marker, positions at least the bulbous portion of the implant in a first stage indicative of a final deployed height of the implant in a second stage.
2. The system of claim 1, wherein the bulbous portion has a teardrop shape in the first stage.
3. The system of claim 1, wherein the bulbous portion has a mushroom shape in the first stage.
4. The system of claim 1, wherein when delivered, a proximal end of the inset is spaced apart from a proximal end of the implant within the bulbous portion.
5. The system of claim 1, wherein when delivered, a proximal end of the tail is positioned at an outer surface of the implant.
6. The system of claim 5, wherein the inset is substantially spherical.
7. The system of claim 5, wherein the inset has an opposing cone shape.
8. The system of claim 5, wherein the inset includes an inverted hub.
9. The system of claim 4, wherein the inset comprises a bulbous portion and the tail is inverted to form a cylindrical shape coupled to the bulbous portion when delivered.
10. The system of claim 9, wherein the inset is adapted to expand from a compressed conical shape.

11. The system of claim 4, wherein the inset comprises a dual-conical shape.
12. A method of implant manufacture comprising:
 - forming an intermediate stage implant preform with a bulbous portion and an inset cylindrical section;
 - heatsetting the intermediate stage implant preform;
 - modifying a shape of the intermediate stage implant preform whereby the inset cylindrical section is changed into another shape to produce a final stage implant preform;
 - heatsetting the final stage implant preform;
 - attaching the implant to an implant pusher; and
 - inserting the implant into a catheter having a distal marker and a proximal reference marker, such that a tail portion of the implant received in a linear configuration within the catheter for delivery defines an inset within a bulbous portion of the implant when delivered;
 - wherein at least one of the pusher or the implant comprises a marker that, when aligned with the proximal reference marker, positions the bulbous portion of the implant in the intermediate stage indicative of a final deployed height of the implant in the final stage.
13. The method of claim 12, where the heatsetting of the final stage implant preform is performed to set only the shape of a modified shape inset.
14. The method of claim 12, wherein the modifying further comprises changing the shape of the bulbous portion and the heatsetting of the final stage implant preform is performed to set each modified shape.

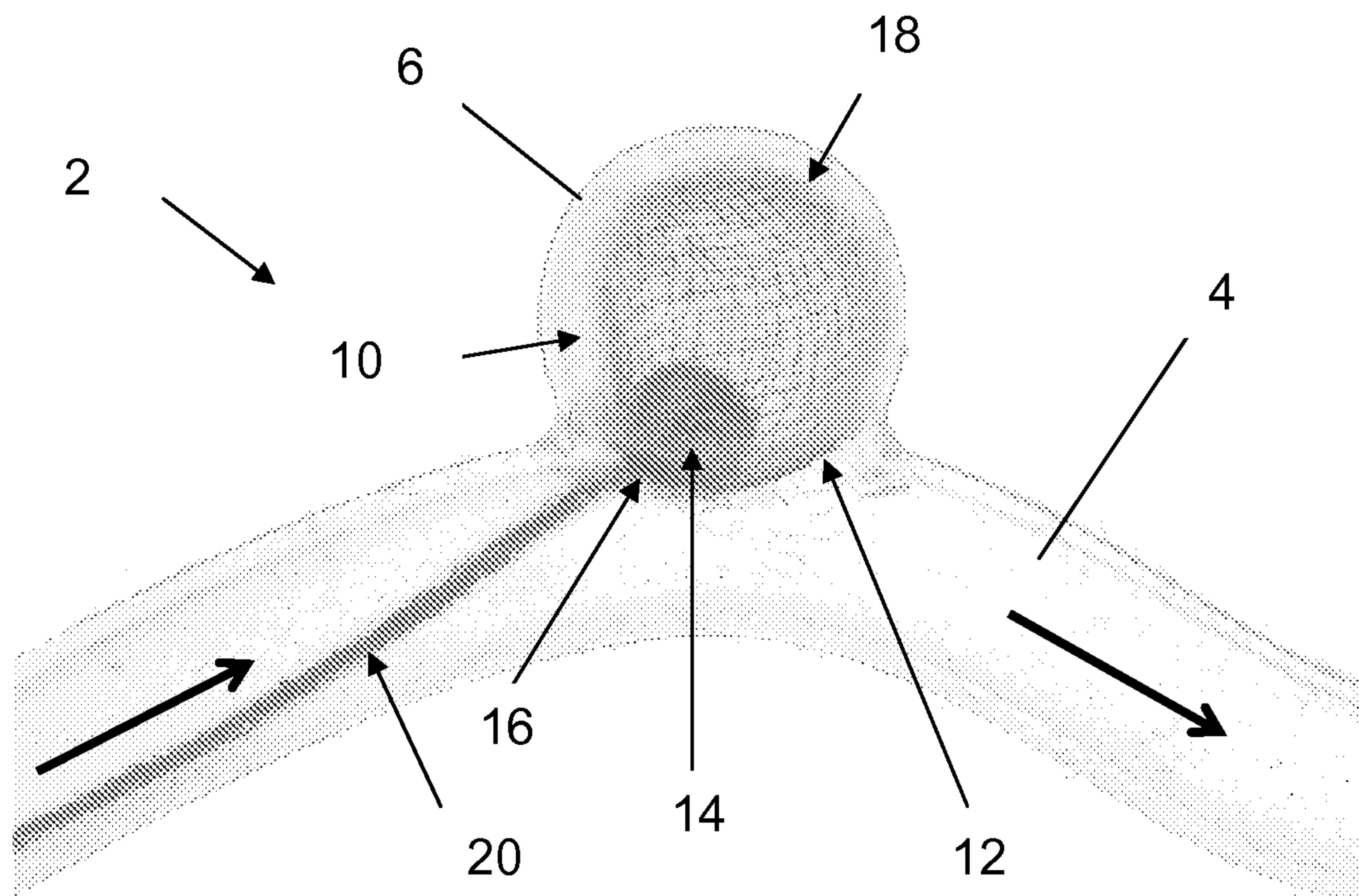

Fig. 1

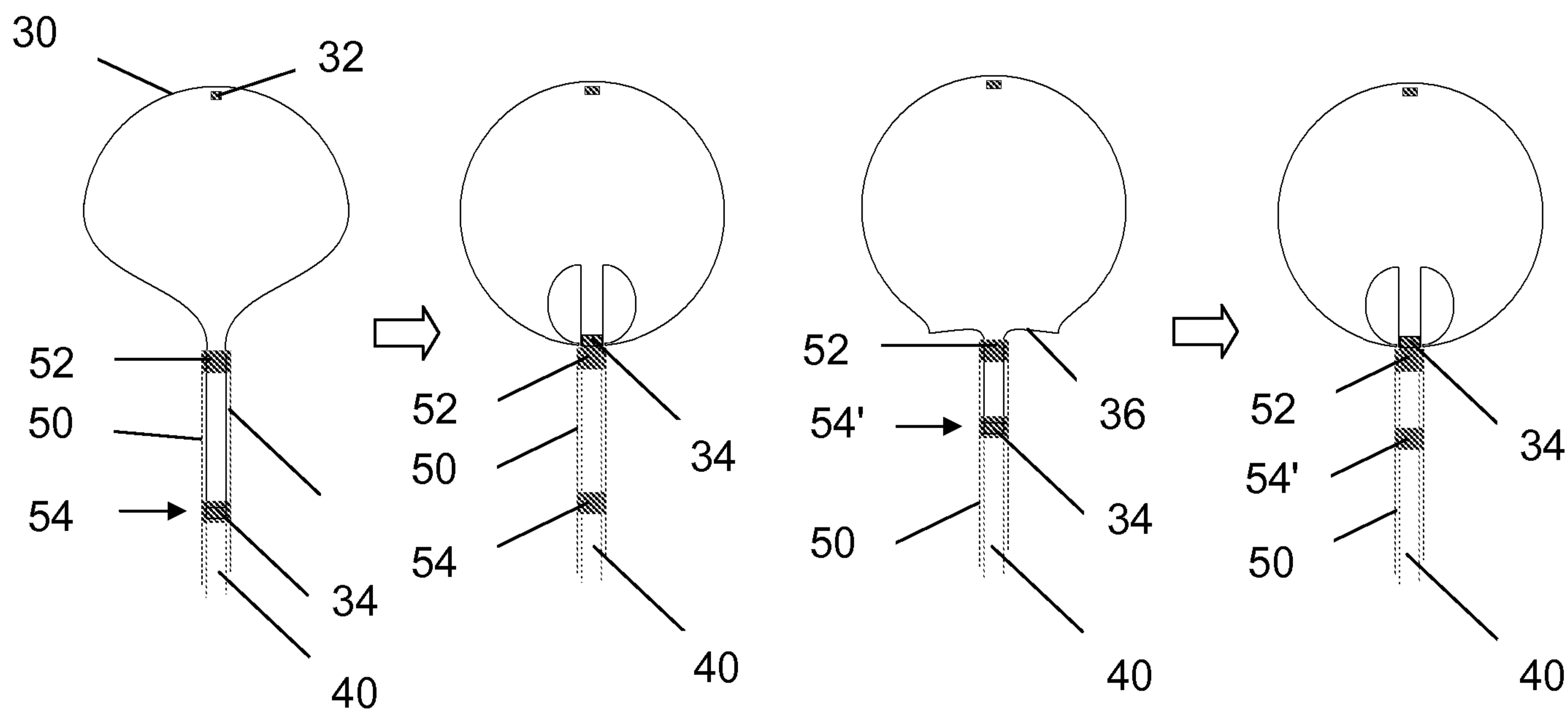

Fig. 2A

Fig. 2B

Fig. 3A

Fig. 3B

Fig. 4A

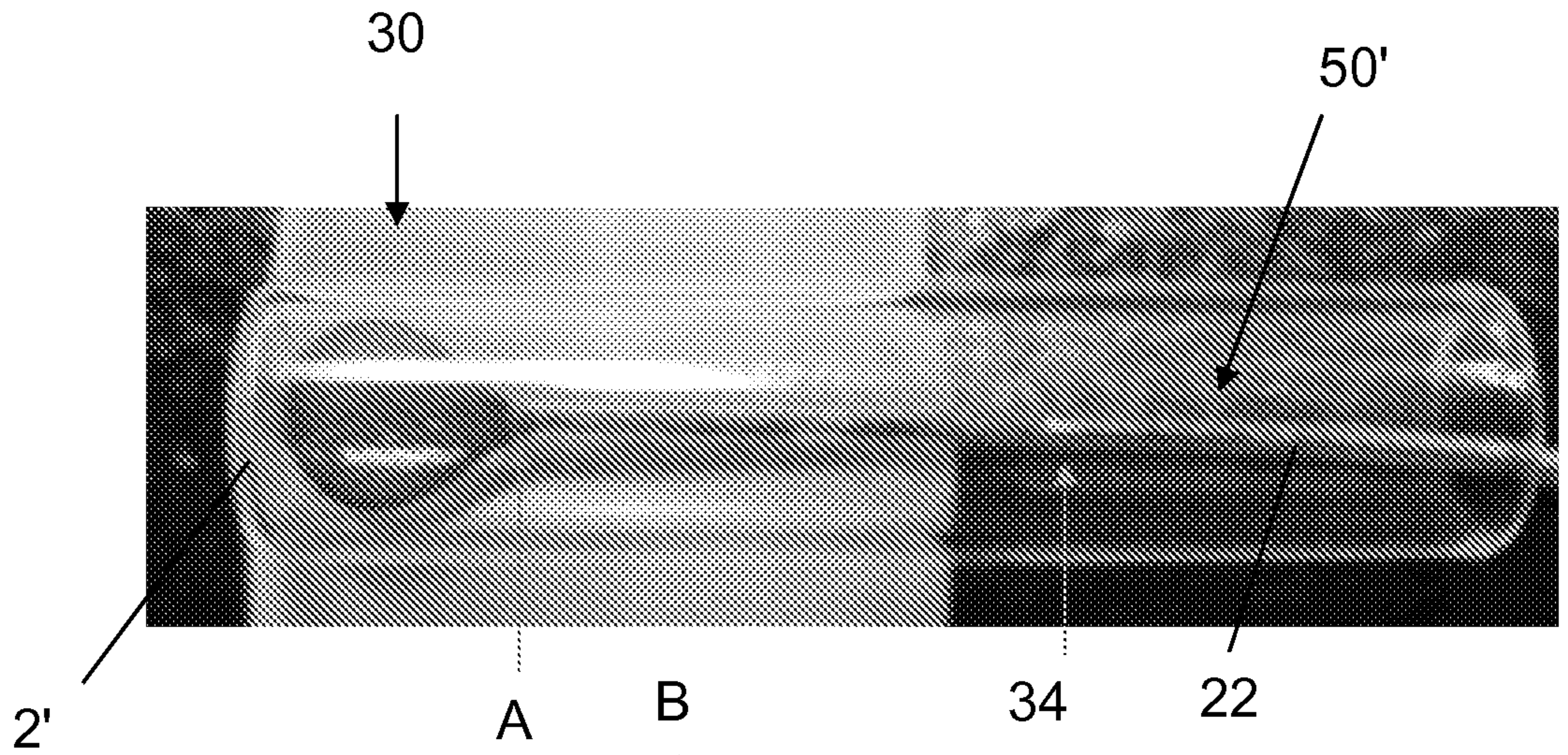

Fig. 4B



Fig. 4C



Fig. 4D

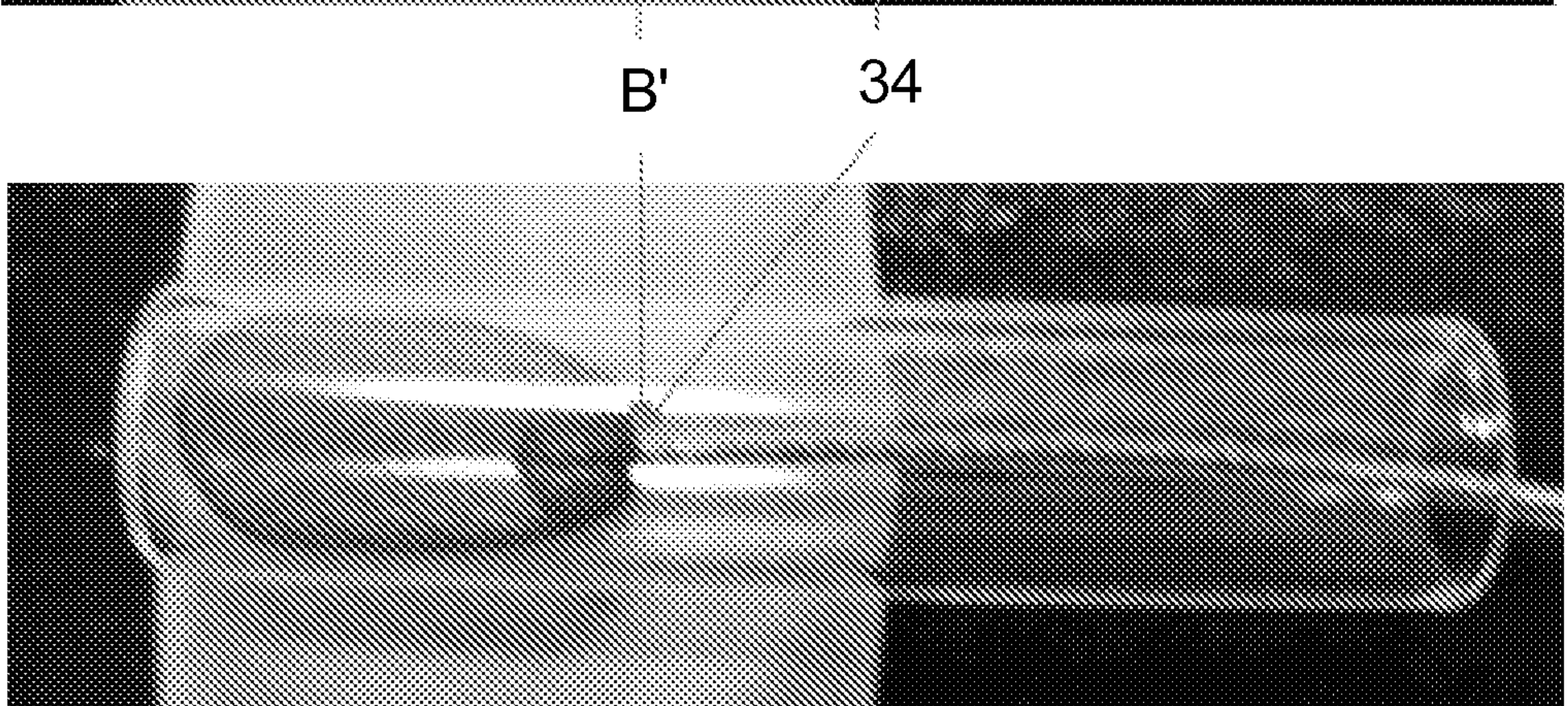

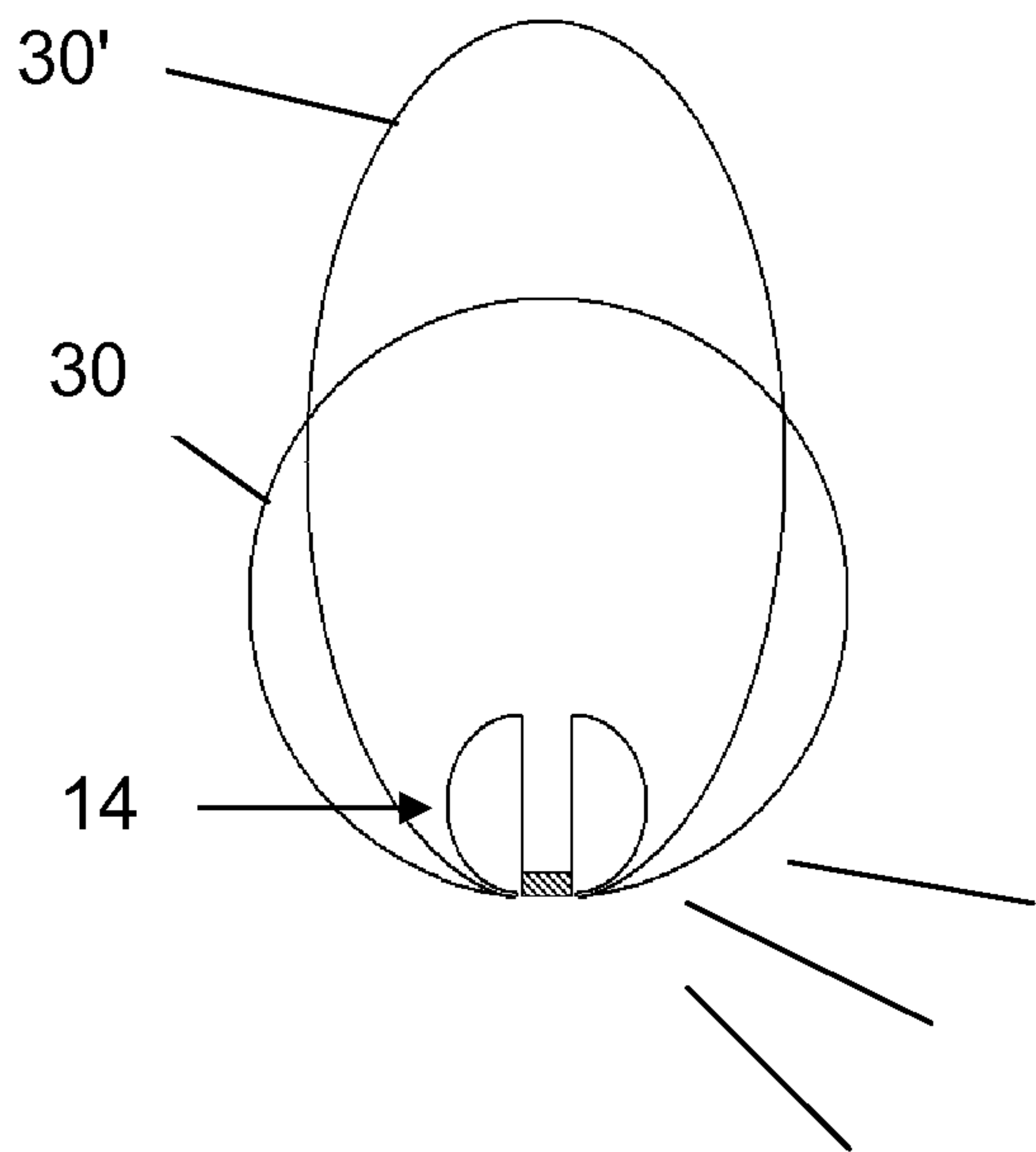

Fig. 5A

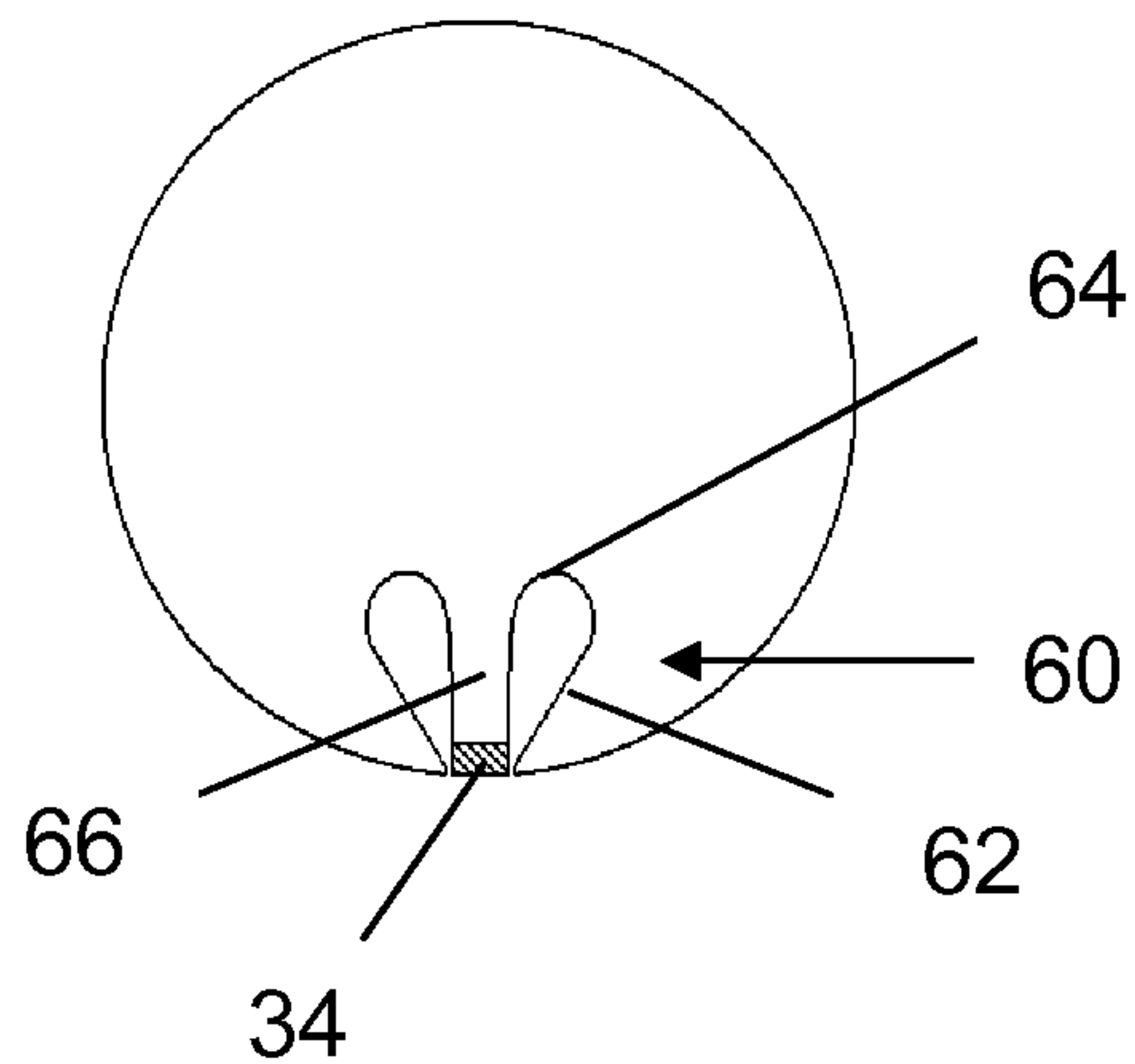

Fig. 5B

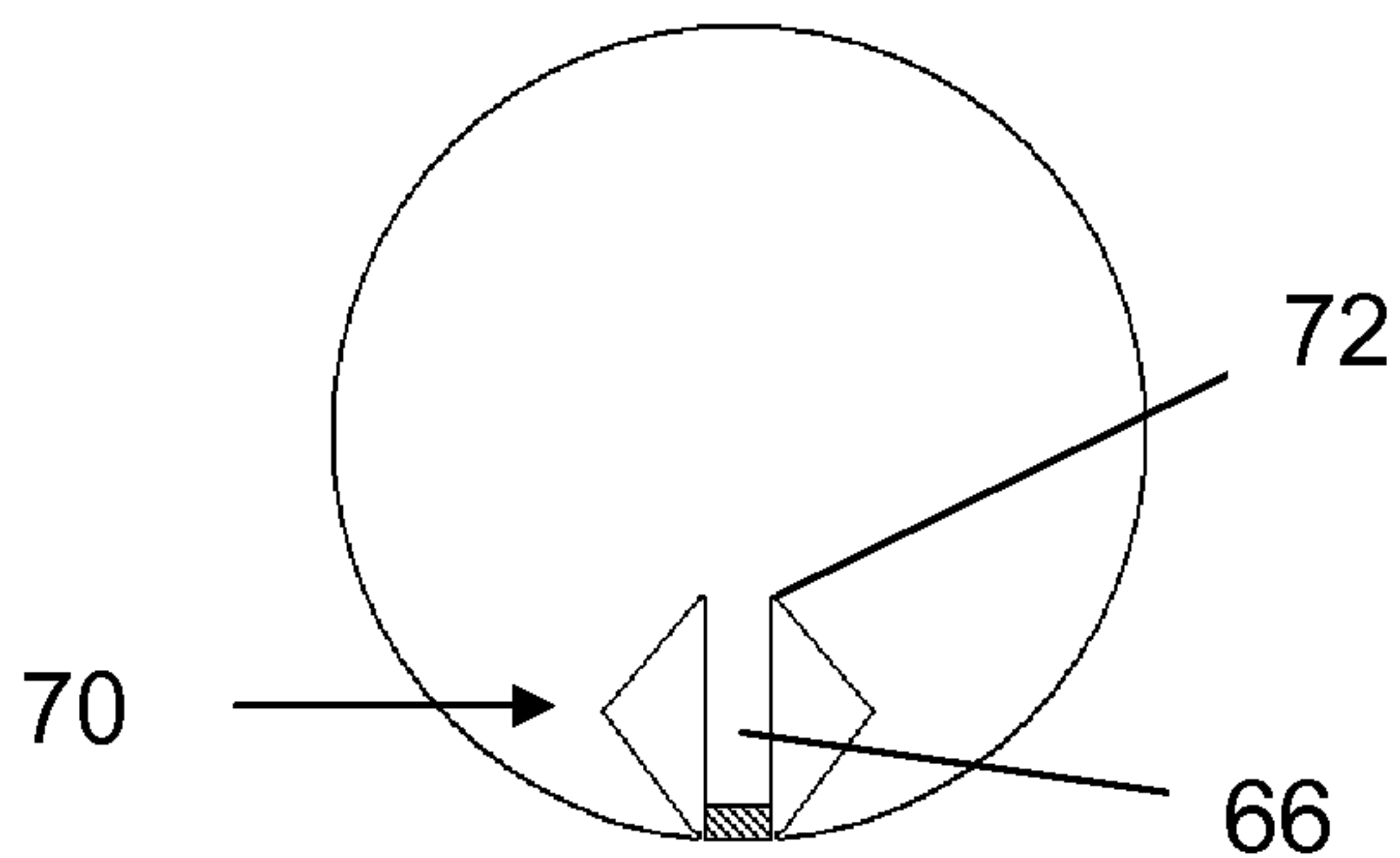

Fig. 5C

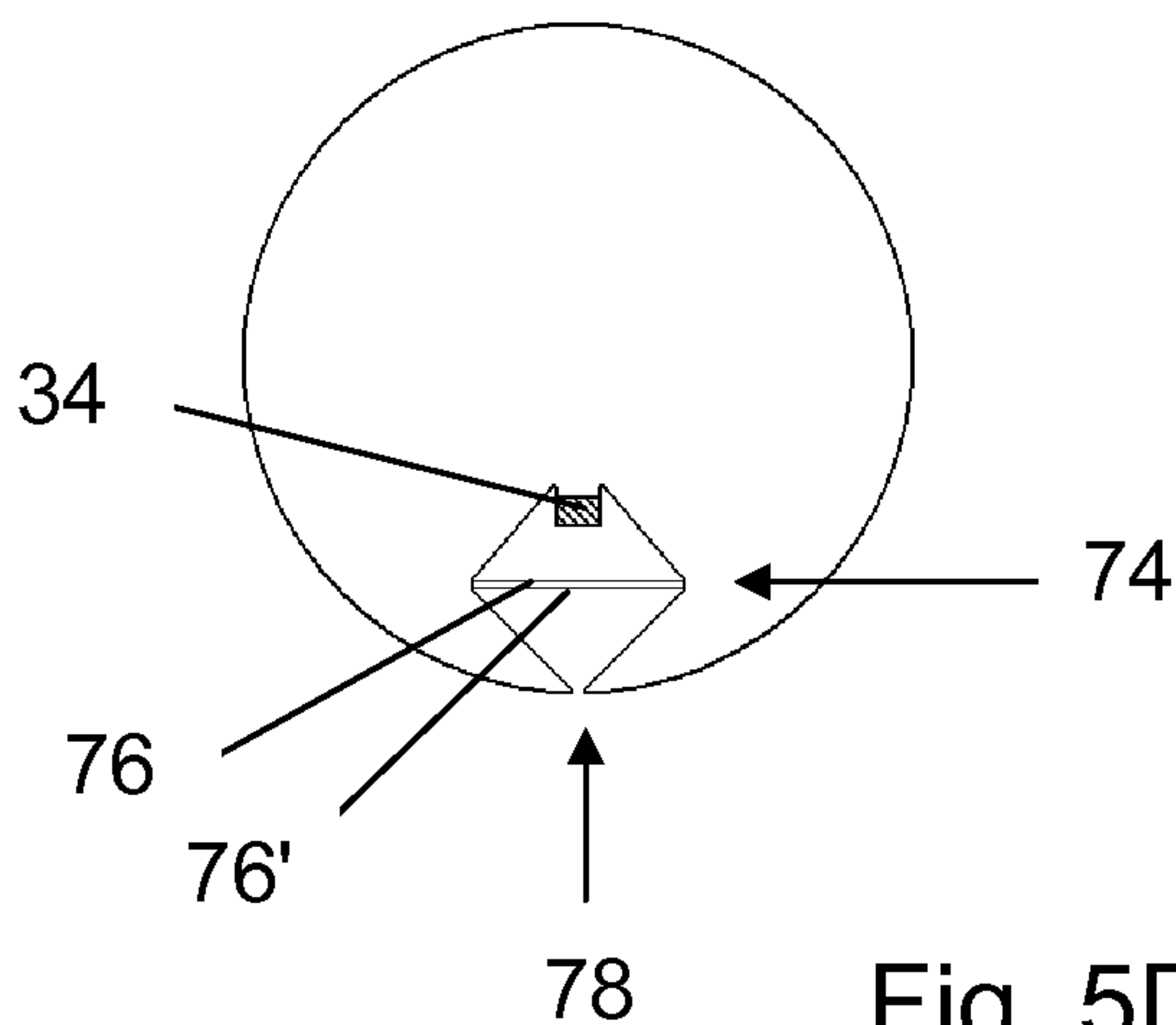

Fig. 5D

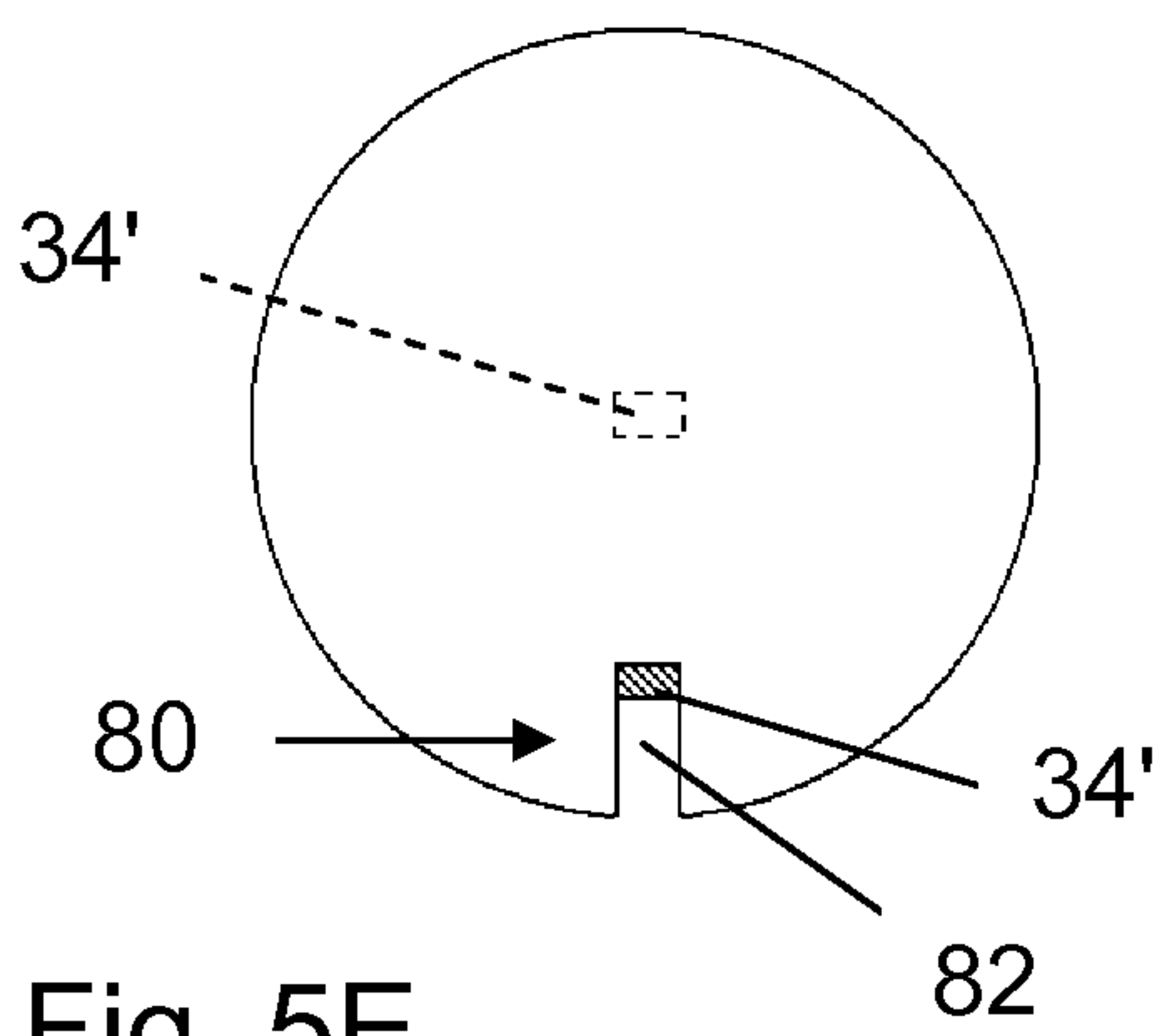

Fig. 5E

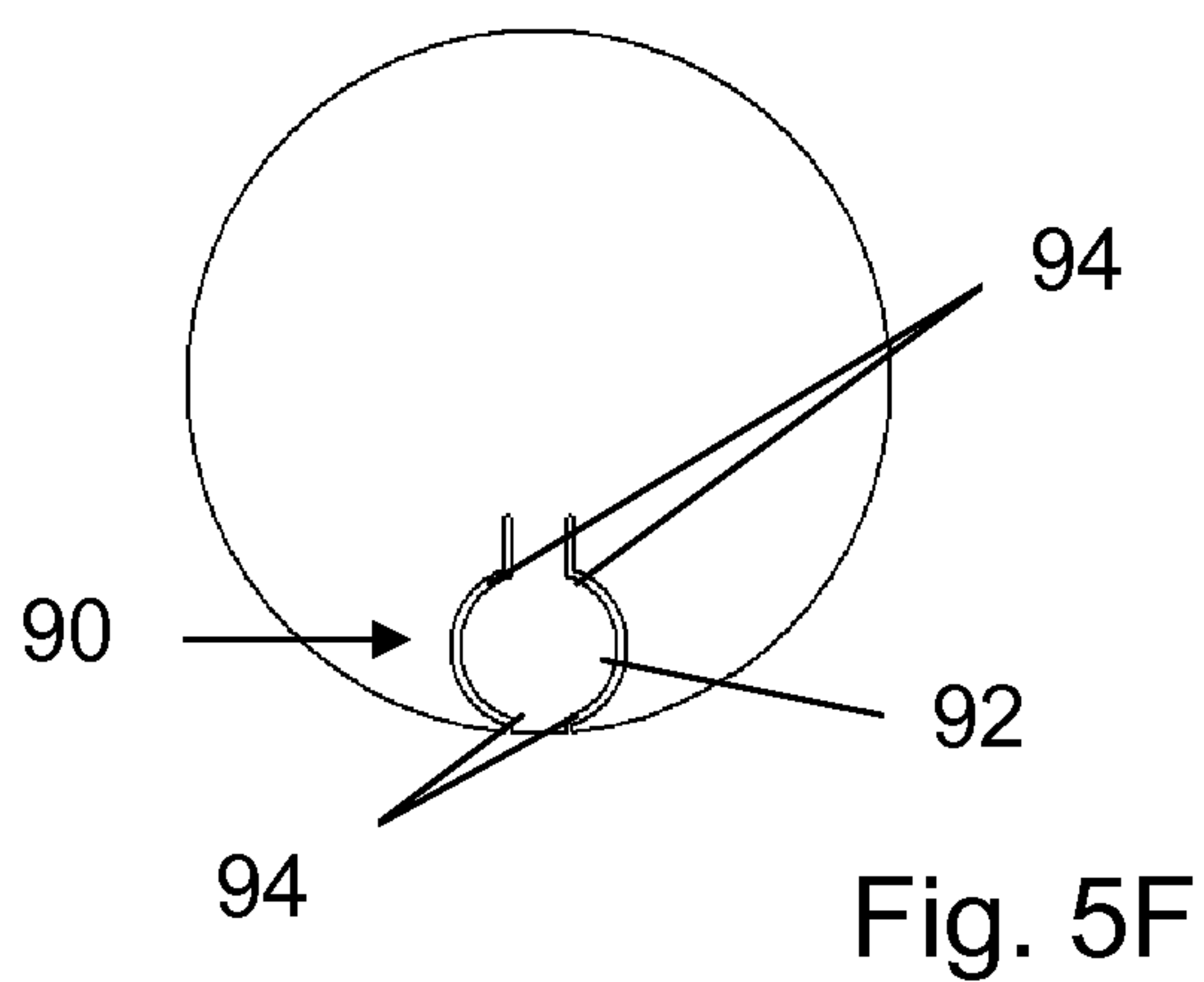
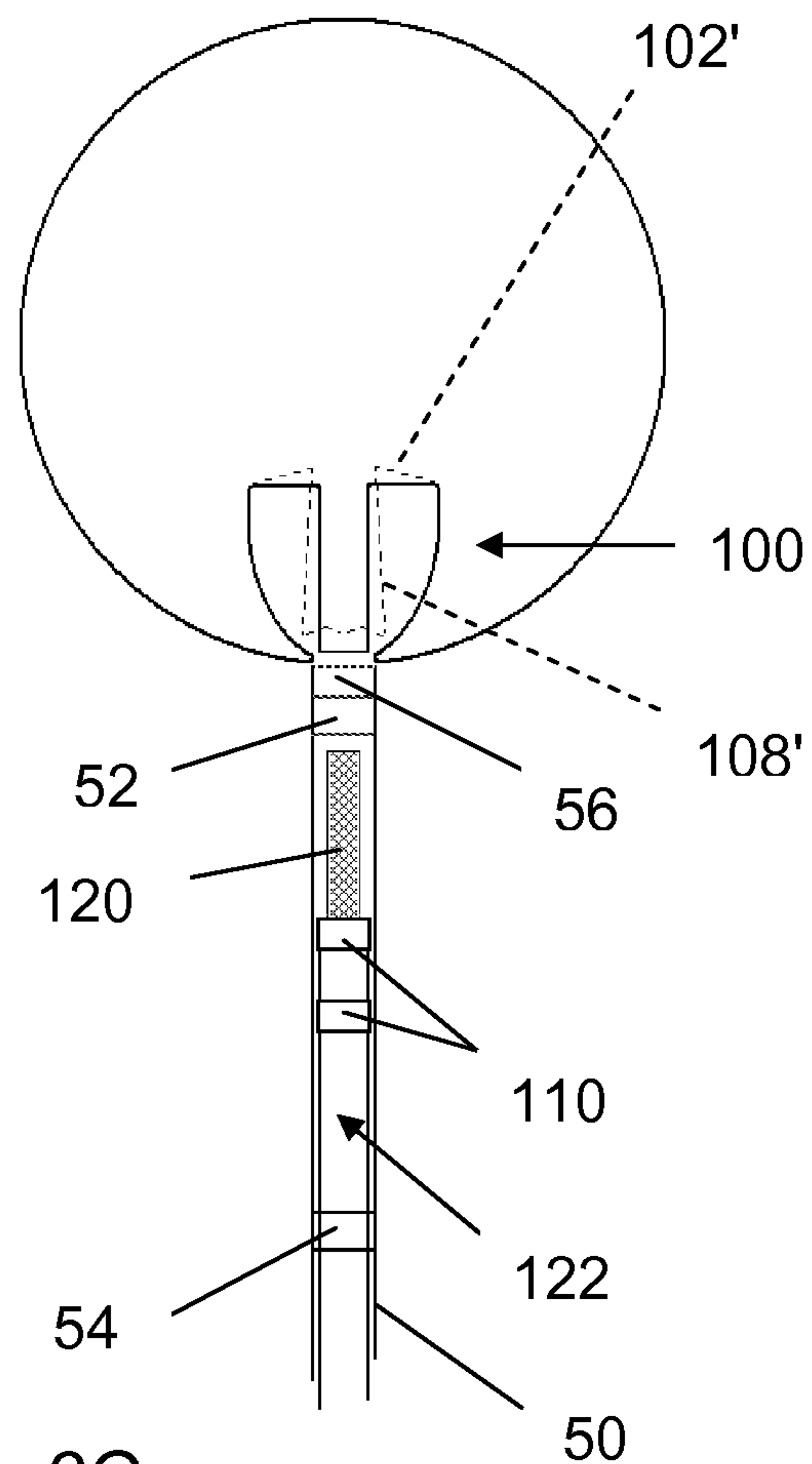
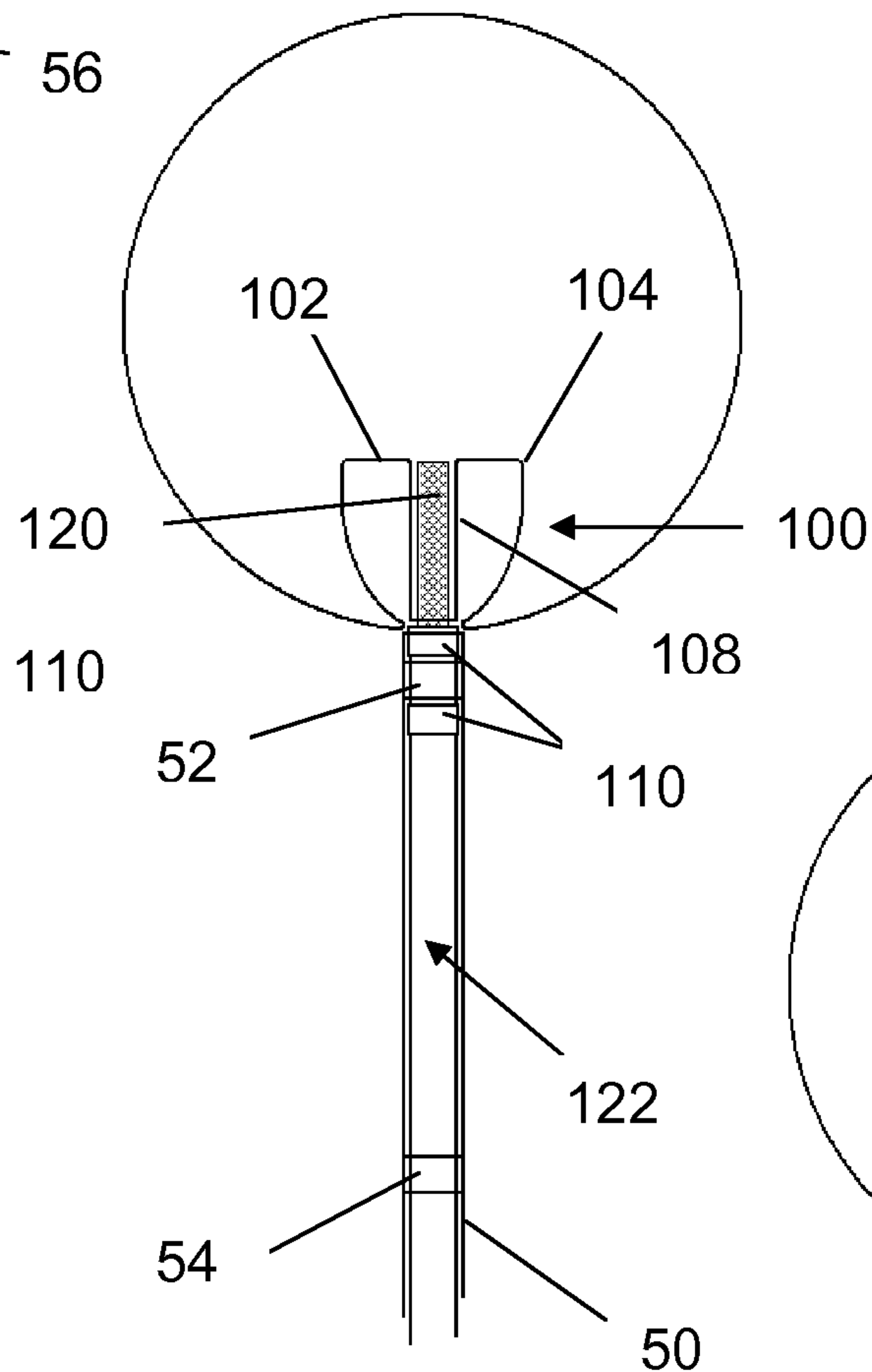
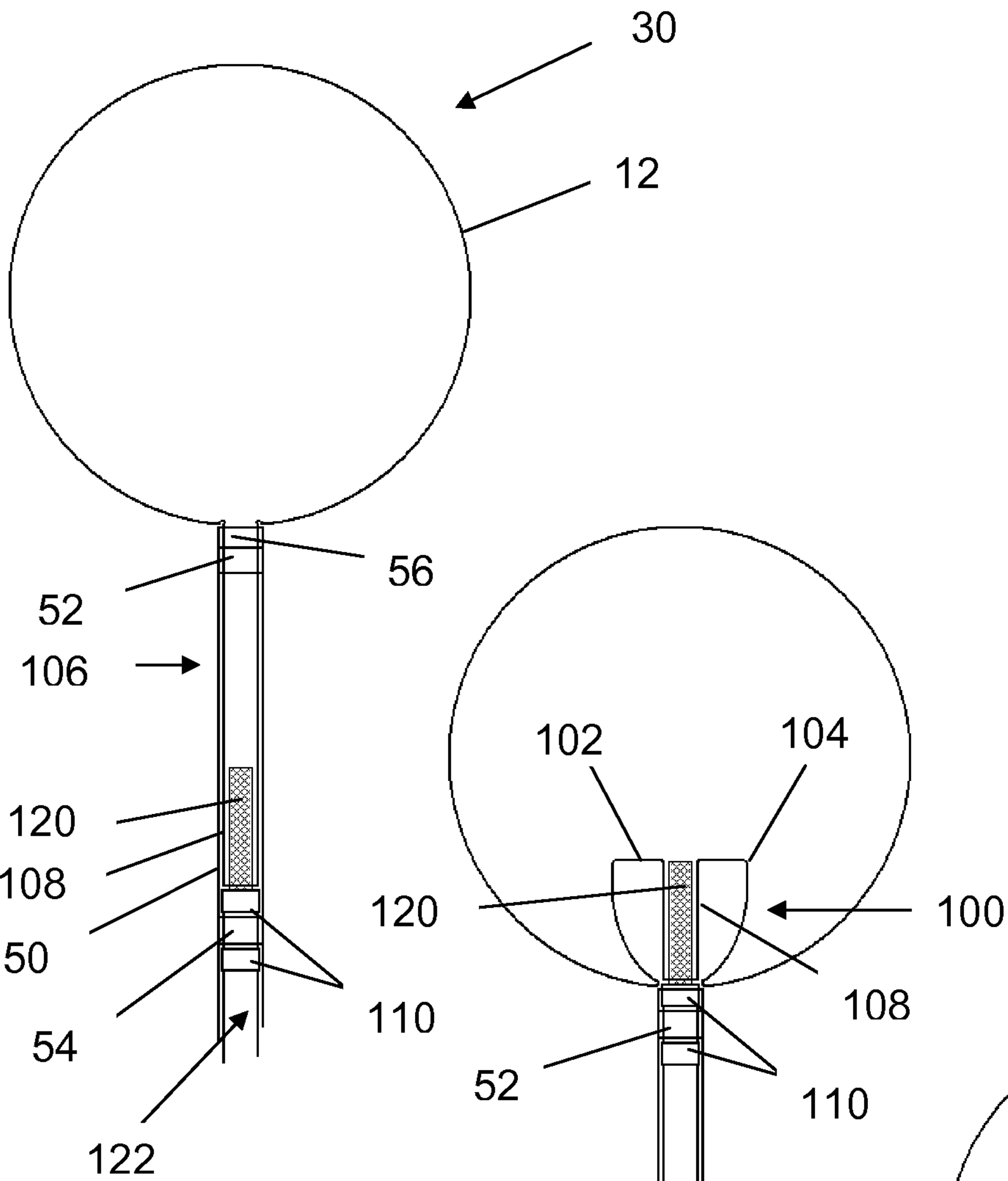
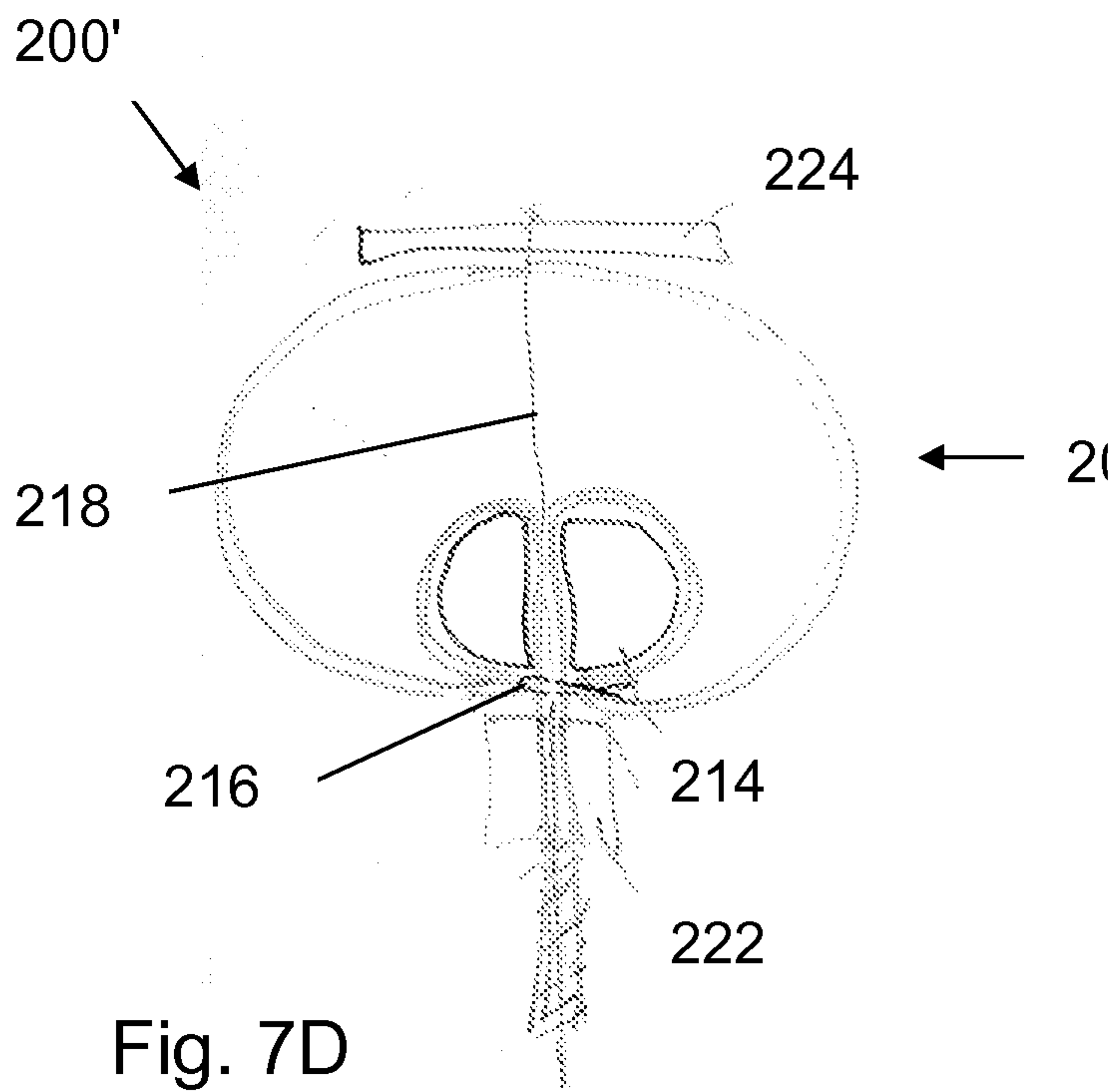
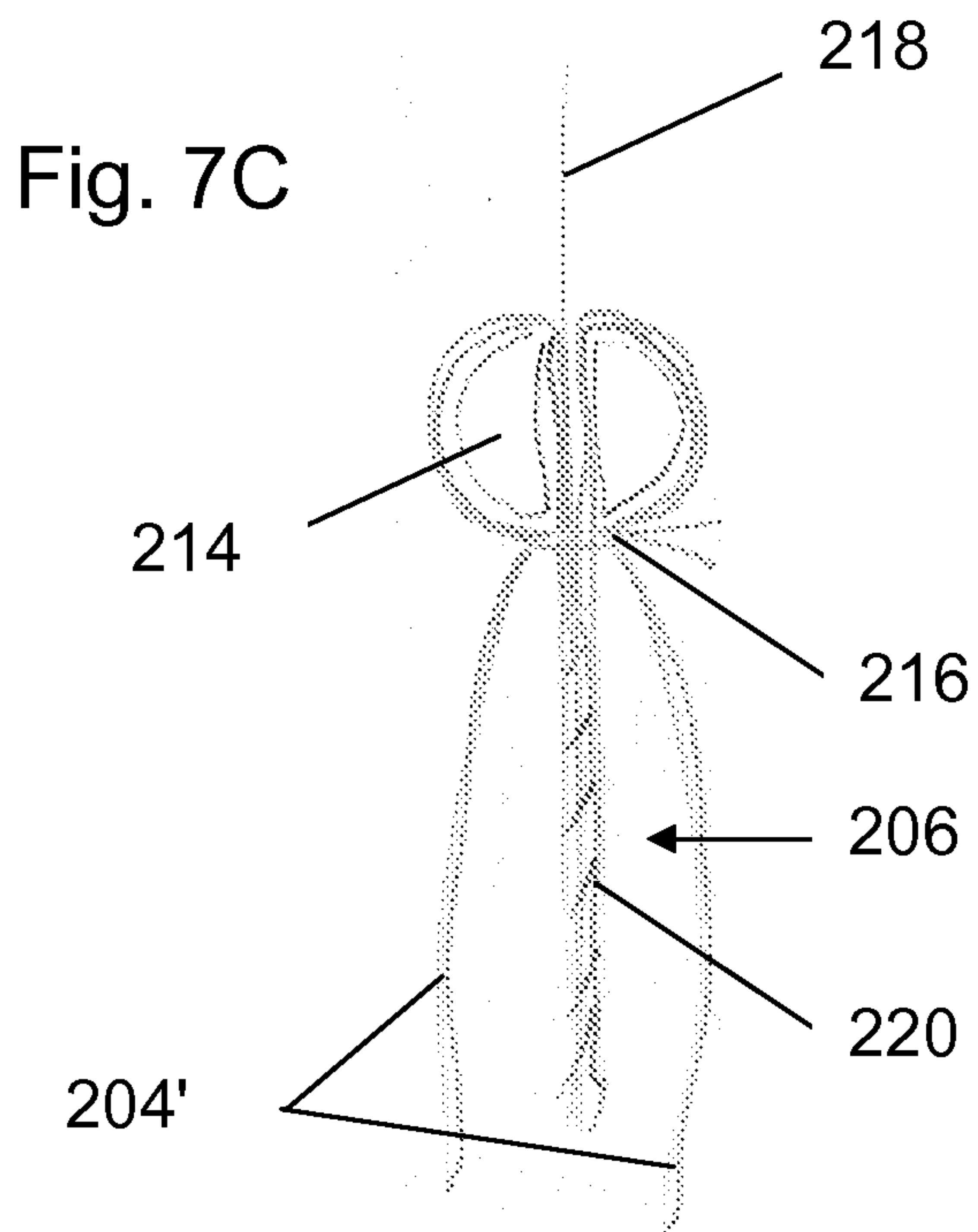
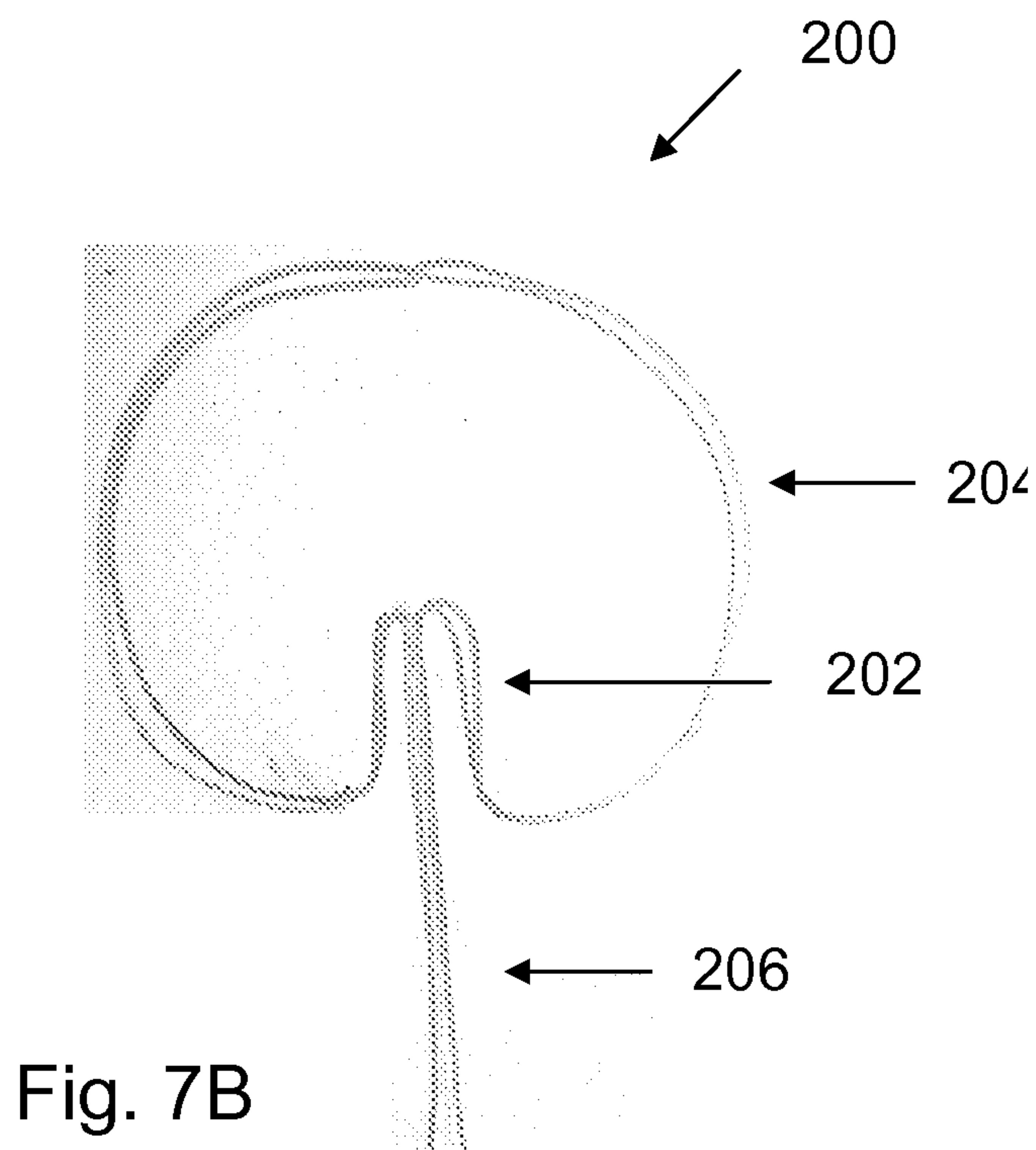
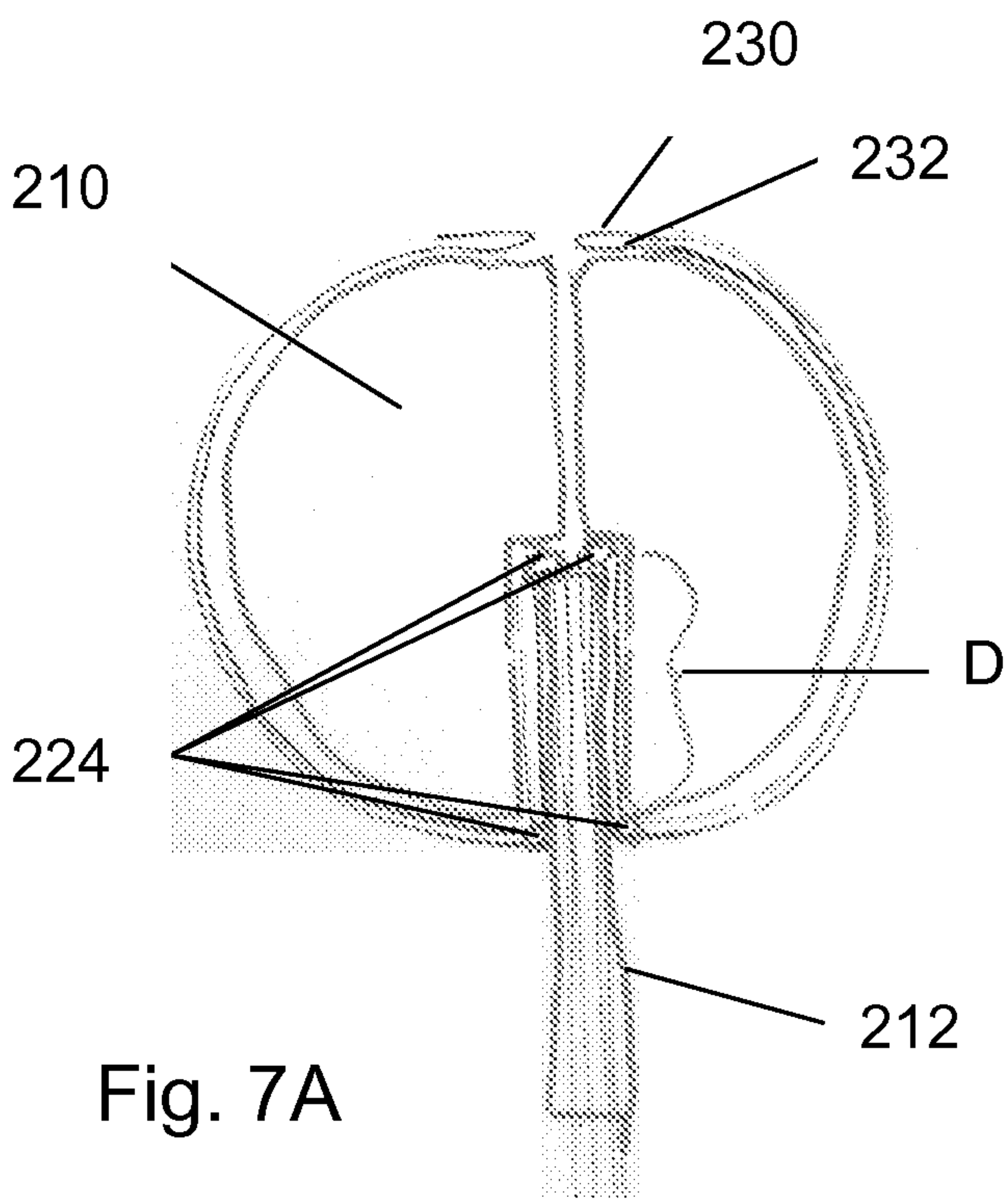

Fig. 5F





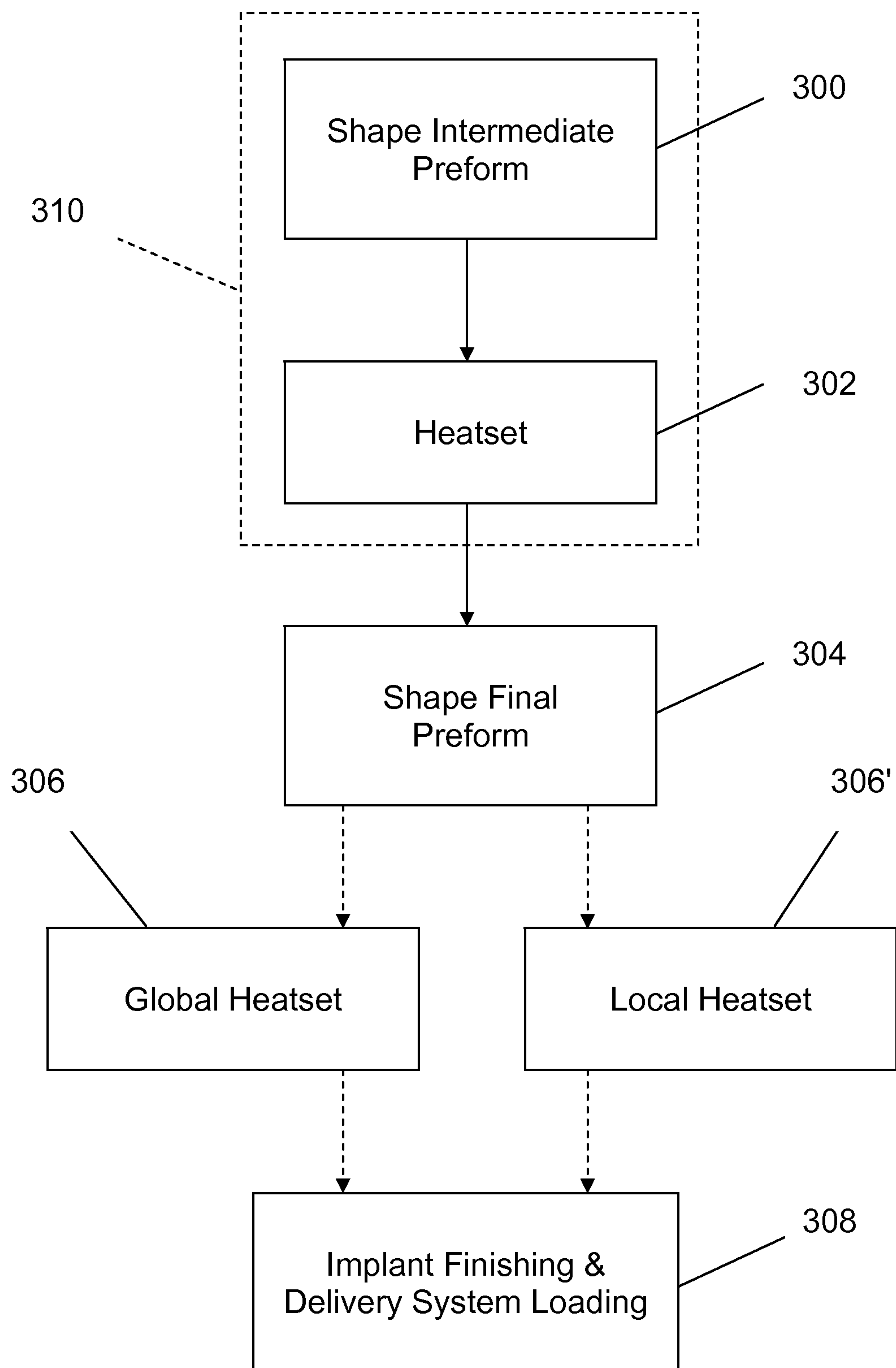

Fig. 8

