

HOWARD & JACKSON.

Buttonholing and Overseaming Attachment for Sewing Machines.

No. 103,745.

Patented May 31, 1870.

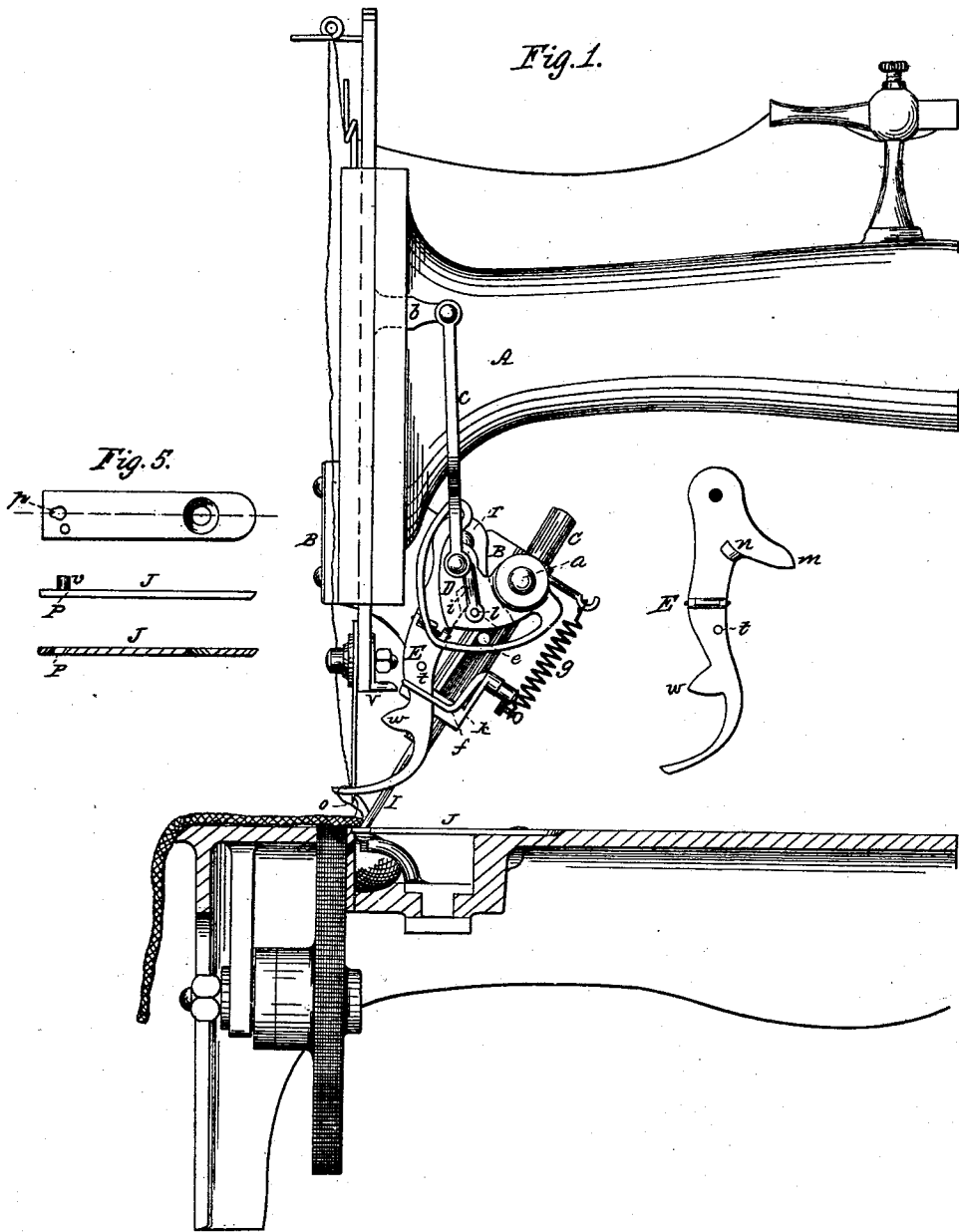

Witnesses:
Thomas Taylor
Phil. T. Dodge

Inventors:
E. Howard &
W. H. Jackson
by Dodge & Munn
their attys

HOWARD & JACKSON.

Buttonholing and Overseaming Attachment for Sewing Machines.

No. 103,745.

Patented May 31, 1870.

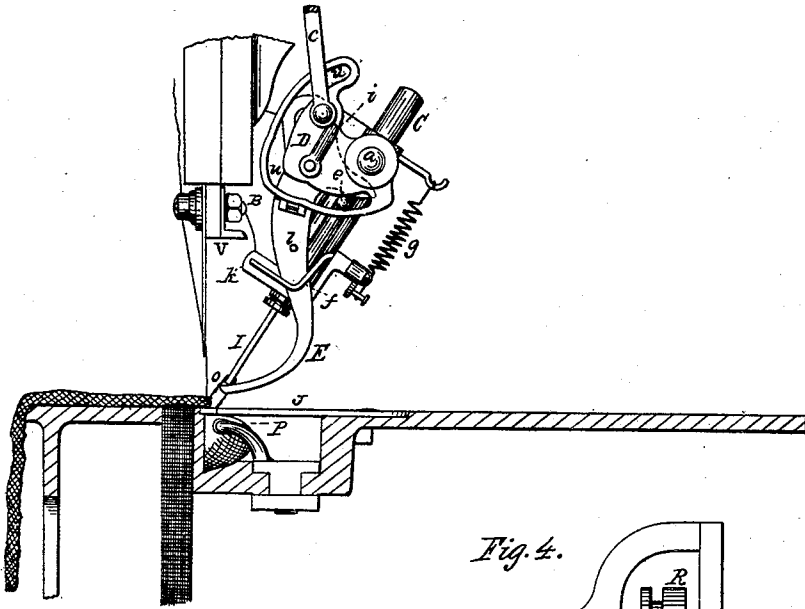

Fig. 4.

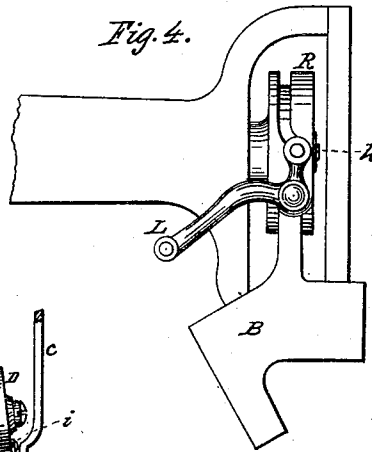
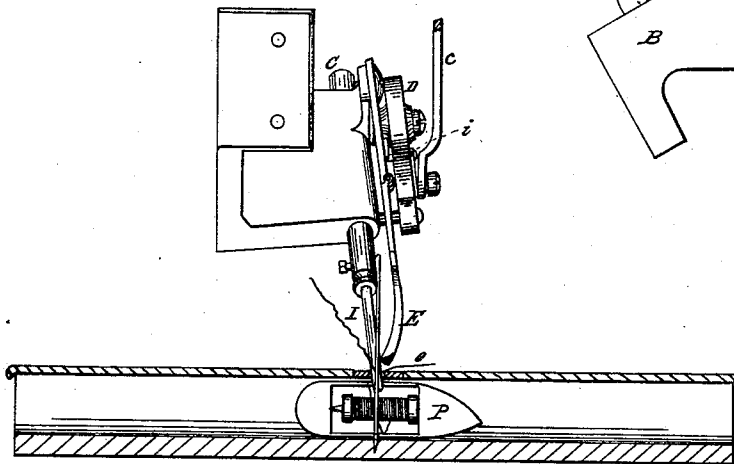

Fig. 3.



Witnesses:
L. Hailer
Phil T. Dodge

Inventors:
E. Howard &
W. K. Jackson
by Dodge & Mun
their Attys

UNITED STATES PATENT OFFICE.

EDMUND HOWARD, OF FLUSHING, AND WILLIAM H. JACKSON, OF
BROOKLYN, NEW YORK.

IMPROVEMENT IN BUTTON-HOLING AND OVERSEAMING ATTACHMENT FOR SEWING-MACHINE.

Specification forming part of Letters Patent No. **103,745**, dated May 31, 1870.

To all whom it may concern:

Be it known that we, EDMUND HOWARD, of Flushing, county of Queens, and WILLIAM H. JACKSON, of Brooklyn, in the county of Kings, and State of New York, have invented certain Improvements in Sewing-Machines, of which the following is a specification, reference being had to the accompanying drawing.

Our invention relates to sewing-machines; and the invention consists in certain mechanical devices to be attached to and operated by and with an ordinary sewing-machine, for the purpose of working button-holes or sewing over the edge of fabrics, as hereinafter more fully explained.

Figure 1 is a side elevation of a portion of a machine, with the apparatus attached. Fig. 2 is a similar view, showing the needle and loopers in a different position. Fig. 3 is a front view of the same. Fig. 4 represents a modification of the operating mechanism; and Fig. 5 are views of the throat-plate, detached.

In the patents heretofore granted to us for an attachment to sewing-machines for working button-holes, &c., the apparatus was so constructed as to be secured horizontally upon the bed of the machine, the looping devices being operated by the shuttle-carrier.

In our present invention the mechanism is connected to the frame over the bed of the machine, and is operated by the needle-bar, or other moving part above, the mechanism being intended to be attached to and used with any ordinary sewing-machine. This attachment or mechanism consists, essentially, of two operating parts, a looper or secondary needle, I, and a vibrating finger, E, both arranged to move intermittently and at certain fixed intervals.

To construct the attachment, we first provide a bracket, B, which is secured by screws to the frame of the needle-bar in such a manner as to bring the attachment in rear of the needle-bar and under the arm or shaft that operates the same, as shown in Fig. 1. In the rear end of this bracket B we mount a slide, C, in the lower end of which is secured a straight needle, I, which has an elongated eye, and which needle we denominate the "looper." This looper, as shown in Figs. 1 and 2, stands

inclined at an angle of about forty-five degrees, and is so located that as it descends its point passes directly under and in the line of the descent of the needle *d* of the sewing-machine, as shown in Fig. 3. To operate this looper I, we pivot on the side of the bracket B a cam, D, which has in it a slot, the first half of which is made eccentric to the pivot, the remaining half, from *u* to *u'*, being made concentric therewith. A pin, *e*, protrudes from the side of the slide C, and enters the slot in the cam D, and the cam is connected by a link, *c*, to the needle-arm, or to a stud, *b*, attached to the needle-bar above, as shown in Fig. 1.

By this arrangement it will be seen that as the needle begins its downward movement the cam D, operating on the slide C, moves the looper I at the same instant, the latter being slightly in advance of the needle, so that the looper is in position first, with its elongated eye directly under the point of the needle, the latter descending and passing through the eye of the looper. As the pin *e* arrives at the point *u* the looper I ceases to move, and remains stationary while the cam completes its motion to *u'* and back to *u* again, during which time the shuttle, or other thread-carrier below, will have passed through the loop of the needle-thread, and the needle be drawn up out of the eye of the looper, when the latter will be raised to its original position ready for another movement. It will be observed that the looper I passes obliquely through a hole in the throat-plate J, just over and so as to clear the shuttle, and under the rim of the feed-wheel or under the feed-ratchet, if such be used.

We also provide a finger, E, which is pivoted at its upper end to the bracket B, in front of the slide C, and between the bracket and the cam D, as shown in Fig. 3.

The general form of this finger is shown in Fig. 1, where it is represented detached. It is made with a joint about midway of its length, to permit its lower portion to be turned up out of the way when desired, it being held in place by a pin, *f*, which is bent in the form of a crank, with its wrist bearing against the side of the finger E, as shown in Figs. 1 and 2. This pin *f* is mounted in a bearing, so as to turn therein, and its opposite end is provided

with a shorter crank, standing at right angle to the first part, this short crank being connected by a spiral spring, *g*, to a pin above.

The tension of the spring thus serves to keep the foot of lower portion of the finger E pressed over against the looper I; and when the lower part of the finger is turned up, the pin *f* is also turned until the short crank is brought on the dead-point, or in line with the spring, which then holds it in that position, the pin *f* then striking against a pin, *t*, which projects from the side of the finger, and thereby holds the finger up, the crank *f* thus serving to hold the finger down to its work, and also up out of the way.

The finger E has three independent movements, which are produced as follows: It has on its rear side an arm, *m*, on its side near the base of this arm an incline, *n*, and on its front edge, toward its lower end, a toe or projection, *w*.

The arm *m* is struck by the pin *e* of the slide C as the latter ascends, which thus throws the finger E back to its rearmost position. At the same time that this occurs, a pin, *l*, which is held by a spring, *i*, secured on the side of the cam D, and the end of which pin protrudes through a hole in the cam, rides up over the incline *n*, and engages against its upper or rear face, so that as the cam descends this pin *l* slides along on the rear face of the incline *n*, and thus throws the finger E forward until the pin slips from behind the incline, the point of the finger, by this movement being thrown forward past the looper and the needle, as in Fig. 1, where it remains until the needle-bar descends, when a projection or toe-piece, V, secured to its lower end, comes in contact with the front projection or toe, *w*, on the spreader E, which drives the spreader back past the needle, with its point close against the looper I, where it remains until the looper is carried nearly to its highest point, when the pin *e*, striking against the under side of the arm *m*, throws the point of the spreader back and under the point of the looper, as represented in Fig. 2.

A plate, *k*, is secured to the lower inner edge of the bracket B, against which the spreader E is pressed by the crank-pin *f*, this plate *k* thus serving as a bearing to guide the spreader in its forward movement, this plate *k* being so set as to permit the point of the spreader to pass under the point of the looper when thrown clear back, and cause it to move obliquely past the needle when thrown forward.

The throat-plate J, as represented in Fig. 5, consists of a single narrow plate secured to the bed of the machine transversely across the shuttle-race, as shown in Figs. 1 and 2. This plate J is provided with a hole, *p*, at its outer end for the passage of the needle and looper, and with a larger hole at its opposite end for a screw, by which it is secured to the bed of the machine. It has also a small stud or pin, *v*, projecting from its upper face in front

of the needle-hole, this pin being intended to enter the slit forming the button-hole, and thus serve to hold it open so as to permit the looper to pass through it, and also to operate as a guide, against which the edge of the fabric rests as it moves along, thus holding the fabric so that it shall not crowd or work over in the way of the looper, and cause the needle to enter the fabric at a uniform distance from the edge.

In Figs. 1, 2, and 3 the attachment is represented as applied to that class of machines which has a vibrating needle-arm; but in Fig. 4 it is represented as applied to that class of machines which has a rotating shaft instead of the vibrating arm for operating the needle. In such cases the cam D is dispensed with, and motion is imparted to the looper-slide by means of an elbow-lever, L, pivoted to an arm of the bracket B, as shown in Fig. 4, the short arm of the lever being provided with a pin, *h*, which engages in a cam-groove on the wheel R, secured to the end of the rotating shaft, the groove being so formed as to give to the lever L, and consequently to the looper I, the required movements. In this case the spring pawl or pin *l*, which rides over the incline *n* on the spreader, is applied to the connecting-link *c*, and operates the same as when applied to the cam in the other case.

It is obvious that many other plans may be adopted to transmit motion from the needle-arm or rotating shaft to the looper and spreader; but those described are simple and efficient, and are amply sufficient for an illustration of the principle or mode of operation of our invention.

The above-described devices constitute the mechanical features of our invention, and their operation is as follows: The shuttle and needle being threaded as for ordinary sewing, and the throat-plate and attachment being secured in position, the cloth is placed under the foot-presser, with the pin *v* in the slit or button-hole or against the edge of the fabric, if it be desired to work the edge simply, and the machine is then set in motion. As it starts the looper I passes obliquely through the slit, under the edge of the material, until its eye comes directly under the needle *d*, which descends and passes through the fabric, and also through the eye of the looper, and down past the shuttle P, or other thread-carrier, as the case may be, this latter passing through the needle-loop in the usual manner. The needle is then drawn up, and as it rises out of the eye of the looper the latter is also drawn back to the position shown in Fig. 2, the thread of the needle, as it is drawn up through the eye of the looper, bringing the shuttle-thread *o* with it, as represented in Fig. 2. At this instant the lower forked end of the spreader E, which has been also brought to the position represented in Fig. 2, engages with that part of the shuttle-thread which is between the looper and the cloth, and immediately carries it over the

upper side of the fabric, thereby forming a loop directly under the needle *d*, as shown in Fig. 1, so that as the needle descends it passes through this loop, and thus locks the shuttle-thread at that point. As soon as the needle has fairly entered the loop on top of the cloth the toe *V*, on the end of the needle-bar, strikes against the projection *w* of the spreader, thereby pushing the latter back to a position directly in rear of the needle and alongside of the looper, where it remains until the looper rises, when the pin *e* of the looper-slide, by striking against the under side of the arm *m*, carries the point of the spreader *E* still farther back, to the position shown in Fig. 2, ready to again engage with the loop of the shuttle-thread for another operation.

It will thus be seen that by these operations the locking of the threads is made upon the upper edge of the fabric, the needle-thread covering the edge of the same, the stitch itself being the same as is produced by our former attachment. By these means we produce an attachment that is simpler and better, and that can be applied to all styles of machines, and which need not be removed for ordinary sewing, as it is only necessary to disconnect the link *c* from the driving bar or shaft, slide back the looper, and then turn up the spreader

out of the way, when the machine can be used the same as though the attachment was not there.

Having thus described our invention, what we claim is—

1. The attachment for forming a button-hole stitch, constructed and operating substantially as described, and arranged to be operated by the needle-arm or shaft from above.

2. The looper *L*, constructed as described, and arranged to move from above diagonally across the line of the needle's movement, under the fabric and over the lower thread-carrier, substantially as described.

3. The spreader *E*, provided with the arm *m*, incline *n*, and toe *w*, arranged to be operated by the spring pawl *i* of cam *D*, the pin *e* of slide *C*, and the toe-piece *V* of the needle-bar, whereby it has imparted to it the intermittent reciprocating movements, substantially as and for the purpose set forth.

4. The hinged spreader *E*, in combination with the bent or crank pin *f* and spring *g*, arranged to operate as set forth.

EDMUND HOWARD.

W. H. JACKSON.

Witnesses:

TH. S. HOWARD,
CHAS. NIEMAN.