

(No Model.)

I. N. HALL.  
COMBINED WATER HEATER AND RANGE.

No. 523,277.

Patented July 17, 1894.

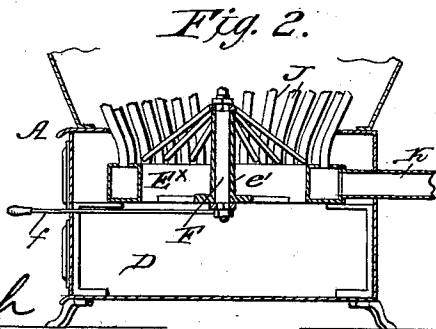
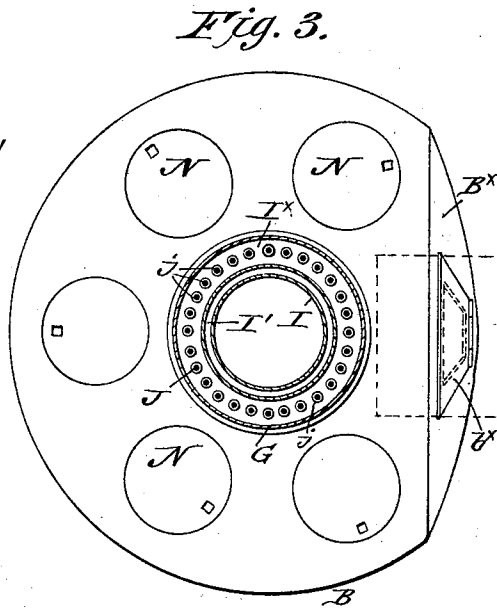
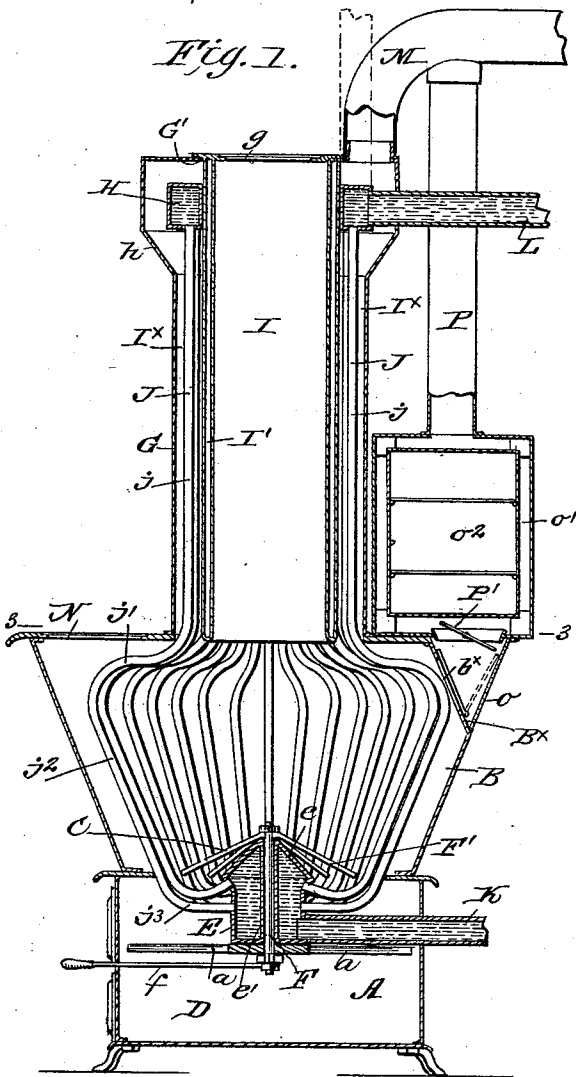

WITNESSES:  
*Fred G. Diterich*  
*W. A. Blouell*

INVENTOR  
*I. N. Hall.*  
BY *Wm. G.*  
ATTORNEYS.

# UNITED STATES PATENT OFFICE.

ISAAC N. HALL, OF MEDIAPOLIS, IOWA.

## COMBINED WATER-HEATER AND RANGE.

SPECIFICATION forming part of Letters Patent No. 523,277, dated July 17, 1894.

Application filed March 31, 1894. Serial No. 505,844. (No model.)

*To all whom it may concern:*

Be it known that I, ISAAC N. HALL, residing at Mediapolis, in the county of Des Moines and State of Iowa, have invented a new and Improved Combined Water-Heater and Range, of which the following is a specification.

My invention relates to a combined water heater and range and it has primarily for its object to provide a heater of this kind of a simple and inexpensive construction which can be set up in a kitchen and used as a range for ordinary purposes and as a means for heating water and causing a circulation thereof through the heating pipes in the several rooms.

Furthermore it has for its object to provide a heating means of this kind in which the combustion chamber and water pipes are so arranged that a large quantity of water can be heated and forced up through the pipes with a small outlay of fuel, and in a very effective manner.

With other objects in view, which herein after will be referred to, the invention consists in the novel construction and peculiar combination of parts, all of which will be first described in detail and then be pointed out in the appended claims, reference being had to the accompanying drawings, in which—

Figure 1 is a vertical section of my improved heater showing the same adapted for burning hard coal. Fig. 2 is a section of the lower portion of the stove showing its combustion chamber constructed to burn soft coal. Fig. 3 is a sectional plan view taken on the line 3—3 Fig. 1.

Referring to the accompanying drawings by letters of reference, A indicates the body or base portion of the stove which comprises a circular inverted cone shaped combustion chamber B, a grate section C and an ash pit D. The grate when the heater is adapted to burn hard coal is constructed substantially in the manner shown in Fig. 1, by reference to which it will be seen that supported centrally on a cross member *a* is a hollow body E having a cone shaped top *e* and through such body, centrally, is projected a tube *e'* which projects above the top *e*. In this tube is held to rock a shaft F having at its upper end the conical grate formed of downwardly

inclined grate fingers F', while its lower end has a shaker or rocker bar *f* adapted to be operated from the outside of the base as shown. Projected centrally from the base is a vertical extension or cylinder G, the upper end of which is slightly enlarged at *h*, in which is held an annular chamber or heater H, fitted about the upper end of the magazine I, which is formed with an annular jacket or space I' to prevent the coal from coking in it and choking and stopping the ready fall of the coal, and such magazine extends to the top of the cylinder G, the feed opening G' of which is held closed by the lid *g* as shown.

Within the space I<sup>x</sup> between the magazine and the cylinder G is held a series of water or circulating pipes J, J, which each consists of a vertical member *j* extended the full length of the space I<sup>x</sup> an outwardly and downwardly curved portion *j'*, inwardly inclined portions *j''* arranged parallel with the sides of the base or combustion chamber, and inwardly curved portions *j'''* which connect with the hollow chamber E.

It will be noticed that by curving the pipes in the manner shown and making them with a long vertical extension practically without a single sharp bend or curve, such arrangement while forming substantially a fire box or fuel holding pot at the lower end, will, owing to the fact that they are free from angles, serve to cause the water to rise more freely and with a much greater force or momentum. It will also be noticed that by forming the several pipes each of a single member entirely free from joints, the trouble heretofore had in making heaters with straight upright pipes having joints, which through unequal expansion break loose, will be avoided.

K indicates the feed water pipe which opens into the chamber E and L the off-take hot water pipe which projects from the holder either in a vertical or horizontal direction as indicated and which supplies the several house pipes, which are arranged in practice in connection with the radiators and expansion tank (not shown).

M indicates the smoke off-take or flue, and N a series of covered openings in the top of the combustion chamber, on which the cooking utensils can be set in the ordinary manner.

At one edge the body portion B of the stove

is cut off as at B<sup>x</sup> to reduce the width sufficient to allow the said heater being passed through a narrow doorway and thereby avoid the necessity of taking it apart to get it in a house. The cut off portion B<sup>x</sup> has a valve opening b<sup>x</sup> over which is adapted to be fitted a pendent extension o of an oven held on the top of the base portion of the stove. This oven it will be noticed has a combustion chamber o' surrounding the baking chamber o<sup>2</sup>, which chamber o' has an off take flue P which discharges into the main off take flue, and a valve or cut off P' in its bottom whereby the heat from the stove proper to the oven can be regulated, it being understood that when the oven is used the valve b<sup>x</sup> is to its open position.

For compactness and to allow a free discharge of the ashes the lower ends of the pipes J are connected with the chamber E alternately one above the other as shown.

When soft coal is used the combustion chamber of the stove is constructed as shown in Fig. 2. In this form the central chamber E is dispensed with and an annular chamber E<sup>x</sup> of a diameter similar to the heater K, with such chamber E<sup>x</sup> the pipes J connect and the feed pipe K discharges. The grate is formed conical as before stated the bars being arranged on a rocker bar and spaced to allow clinkers and hard stones to pass through.

From the foregoing description taken in connection with the drawings, it is thought the complete operation and advantages of my improvement will readily appear. It will be observed that the construction is of such a nature that a single stove will serve to heat the entire house and also serve as a cooking range, in a quick and economical manner.

Having thus described my invention, what I claim, and desire to secure by Letters Patent, is—

1. An improved heater of the kind described, comprising an upper water distributing chamber, a series of pendent feed pipes, bent to form a fuel holding pot at the lower end, with their ends extended radially inward to form a grate portion, and a centrally disposed water heating chamber, connecting the ends of the grate portions of the pipes, substantially as shown and for the purposes described.

2. An improved heater of the kind described comprising an inverted conical like body having a central upwardly extended fuel magazine or cylinder, a water distributing chamber held at the upper end of such magazine, a water holding chamber held centrally at the base of the body and the feed pipes, connected with the water distributing chamber, passed down on the outside of the magazine into the stove body, and having portions curved outwardly under the top of such body, and inwardly curved portions connected with the water holding chamber and adapted to form a grate portion all arranged substantially as shown and described.

3. An improved heater comprising a main body or heating chamber, having at its base a centrally disposed water receiving chamber, a water distributing chamber held above the main body, a series of feed pipes connecting the water receiving and distributing chambers, arranged to form the fuel holding chamber and grate portion, a rocker stem projected centrally of the water holding chamber into the fuel chamber having radial downwardly inclined arms and means for rocking such stem and arms substantially as and for the purposes described.

4. In a heater of the character described, the combination with a body portion, having a central vertical extension having an off take at the top, a magazine having a surrounding jacket, held in such cylinder, a distributing water chamber held in the top of the cylinder, a conical grate held in the bottom of the body portion, a water receiving chamber held under the grate, a series of circulating pipes connected at one end to the water receiving chamber, curved outward and inward within the body portion to form a fuel pot, and terminating in straight portions projected up between the magazine jacket and the cylinder and connected with the distributing chamber all substantially as shown and for the purposes described.

5. In a heater for the purpose described, the combination with the combustion portion, formed of a circular inverted cone shaped body having a portion cut off at one end, having a heat outlet, a central magazine and combustion cylinder surrounding such magazine provided with an off take, of an oven, having a pendent portion adapted to fit over the heat outlet in the cut off portion, and having a combustion chamber, a valve over its inlet opening, a heating chamber, and an off take connecting the said oven combustion chamber and the main off take flue all arranged substantially as shown and described.

6. In a heater for the purpose described the combination with the main or body portion having a contracted fire holding portion, a water receiving chamber projected up into such contracted portion, a rocker shaft projected up through such chamber having a conically arranged grate at the upper end, a magazine chamber and a surrounding cylinder projected up from the body portion, the cylinder having an off take flue, a water distributing chamber held in the upper end of the cylinder, and the circulating pipes consisting each of an upper straight portion, and a lower portion curved to be extended parallel with the sides of the body portion and turned inward to connect with the water receiving chamber and to form a bottom member of the fire pot all substantially as shown and described.

7. An improved heater of the kind described, comprising a body portion having a water heating chamber at the lower end, formed

with a central opening an upper or distrib-  
ing chamber, a series of feed pipes connect-  
ing the upper and lower chambers, having  
their lower portions curved to form a fuel  
5 holding pot, and a rocker stem projected up  
through the opening in the lower water cham-  
ber, and having radial arms extended to form

a grate portion, all arranged substantially as  
shown and for the purposes described.

ISAAC N. HALL.

Witnesses:

WM. HARPER,  
SAML. B. HEIZER.