

C. ELLIS.
PROCESS OF MAKING A THICKENED OIL PRODUCT.
APPLICATION FILED SEPT. 9, 1913.

1,180,025.

Patented Apr. 18, 1916.

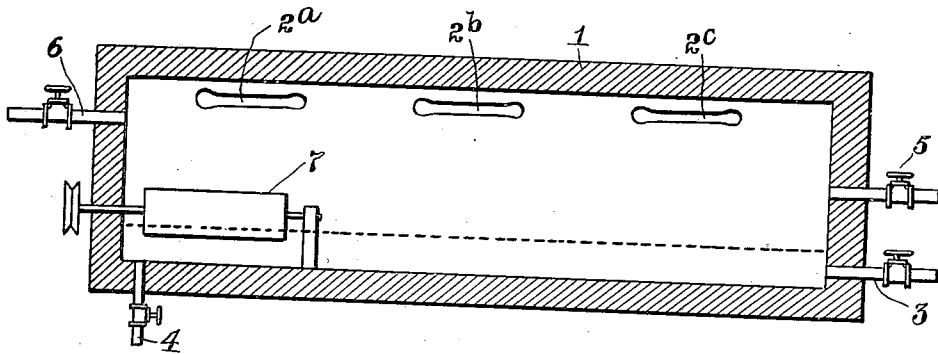

Attest:
W. Mitchell

Inventor:
Charles Ellis

UNITED STATES PATENT OFFICE.

CARLETON ELLIS, OF MONTCLAIR, NEW JERSEY.

PROCESS OF MAKING A THICKENED-OIL PRODUCT.

1,180,025.

Specification of Letters Patent.

Patented Apr. 18, 1916.

Application filed September 9, 1913. Serial No. 788,811.

To all whom it may concern:

Be it known that I, CARLETON ELLIS, a citizen of the United States, and a resident of Montclair, in the county of Essex and State of New Jersey, have invented certain new and useful Processes of Making a Thickened-Oil Product, of which the following is a specification.

This invention relates to thickened oils and relates in part to the treatment of fatty oils or fatty material with ultraviolet light in an oxidizing, reducing or neutral atmosphere, under pressure or *in vacuo* at suitable temperatures, whereby products of improved stability or consistency and color result.

In the past, various proposals have been made to employ actinic light to accelerate reactions, bleach oils, etc., but so far as I am advised the peculiar qualities of ultra violet radiation have not been commercially so employed heretofore.

As the preferred source of ultraviolet radiation I may employ a quartz mercury lamp operated preferably at a voltage of 150 or over. High voltage effects are better suited for the purposes herein set forth and lamps operated at several hundred volts are useful for some applications. The greater the voltage within certain limits the richer is the radiation in rays adapted for oil treatment. The greater part of the unsaturated components of fatty oils when exposed to a source of light of this character polymerize more or less, forming certain stable products of a useful nature. If exposed simultaneously to the light and to oxygen or air the resulting products are more or less oxidized, oxy-fatty acids or glycerids being formed in some cases. Neutral or reducing atmospheres also may be maintained. The gases surrounding the oil may be above or below atmospheric pressure. In treating an oil giving off much vapor it is desirable to use diminished pressure in order to tend to keep such vapor out of contact with the lamp. The ultraviolet radiation is easily impeded and vapors coming in contact with the highly heated quartz tube form a coating which affects the character of the radiation to a marked degree. Accordingly means should preferably be employed to preclude loss of activity from this cause.

The temperature has considerable influence on the rate of polymerization and fairly high temperatures are best main-

tained although for oils which are very sensitive to temperature effects under these conditions and decompose undesirably suitable cooling means may be provided. As a rule a temperature of 100° C. or over is to be recommended as effective for many oils. Moreover this temperature suffices to cause the expulsion of water which may be formed in the course of the reaction and this is desirable. A vacuum may be maintained to remove the water vapor or these may be swept out by a current of an indifferent gas. It is best to thoroughly dry oils before exposure, except when treating at high temperatures. This does not preclude treating oils in the presence of moisture especially certain mixtures of fatty acids.

With 3-5 amperes and 150 volts at the lamp, a light intensity approaching 2500 candles may be secured per unit. The candle power does not however form an adequate measure of the polymerizing intensity, which largely depends on the specific rays. A series of light units may be arranged as a battery above a tank containing the oil to be treated. Care should be taken to shield the operator from the light as serious burns will result from short exposure and in fact an exposure almost momentary is liable to cause blindness.

In the tank there may be placed a drum or a series of disks of a rotatable character so arranged that a portion will dip slightly below the surface of the oil and on rotation will carry upward a film of oil on which the ultraviolet rays impinge. The drum may be of wire gauze to better permit the penetration of the rays to the main body of oil. Sheets of fused quartz may be arranged as paddles, if desired.

The drawings show in longitudinal section an apparatus adapted for carrying out the process hereof.

In these diagrammatic drawings 1 is a chamber of considerable length having the ultra violet lights 2^a, 2^b and 2^c.

3 is an inlet for the admission of oil and 4 an outlet therefor.

5 is an inlet for the admission of steam or inert gas and the like and 6 is outlet therefor.

7 is a rotatable cylinder the lower part of which touches the oily layer and on rotation of this cylinder the oil is exposed as a film to the action of the light.

110

In the operation of this apparatus an oil such as cottonseed oil is substantially freed from moisture and is exposed as a thin layer in an atmosphere of carbon dioxide to the action of the ultraviolet rays. The oil flows past one light after another and the hydrogen number is reduced by such exposure to about 80 or 90. The temperature of operation under these conditions is usually between 75-95° C.

By exposure in this manner, linseed oil forms a solid product with an iodine number less than one half the iodine number of the untreated oil. Wood oil is very quickly solidified to a transparent rubbery material. Fish and whale oils are deodorized and the color improved. Corn and castor oils are variously modified. Cotton oil on relatively short exposure is bleached and thickened. A castor-oil-like viscosity may be obtained without the discoloration often attendant on making blown oils. Longer exposure gives an elastic solid, of a somewhat rubbery nature. The product is light and transparent. The iodine number by the treatment falls from above 100 to 50 or so. The product in part at least is insoluble in solvents such as ether or chloroform, but dissolves fairly well in hot fatty oil, as cotton oil, modifying the viscosity of the latter. By further treatment more insoluble bodies are secured. A light-treated cotton oil of high viscosity, or a similar mixture of cotton and corn oil may be hydrogenated to give an edible product. For this purpose even crude cotton oil may be used as the light radiation of this character bleaches the oil in large measure and also purifies it. After hydrogenation the product, if desired, may be treated with superheated steam *in vacuo*.

The light-treated oils may be used to advantage in lubricants, varnishes, printing inks, linoleum, rubber substitutes and the like.

The treatment of oils of the character herein referred to in the form of a relatively thick layer is claimed in my copending application Serial No. 793,334 filed Oct. 4, 1913.

What I claim is;—

1. The process of modifying the consistency of fatty oils which comprises exposing same in a substantially non-oxidizing

atmosphere to the rays of a very powerful source of ultra violet light for a sufficient length of time to substantially increase the viscosity of the fatty oil.

2. The process of making a thickened oil product which comprises exposing an oil in a substantially non-oxidizing atmosphere containing glycerid to a very powerful source of ultra violet light, so as to concentrate the rays therefrom on a comparatively thin film of glycerid containing material.

3. The process of making a thickened fatty oil which comprises exposing a fatty oil as a moving film in a substantially non-oxidizing atmosphere to ultra violet radiation.

4. The process of improving the quality of oil material substantially free from petroleum oil which comprises exposing such material in a substantially non-oxidizing atmosphere to a concentrated source of ultra violet radiation and in applying the rays locally to relatively thin layers of said material.

5. A process of treating fatty oils, which comprises subjecting liquid, dry, fatty oils, to the action of ultra-violet rays, for a length of time sufficient to produce a thickening of the oil.

6. A process of treating oils which comprises subjecting oil to the action of ultra-violet rays, for a sufficient length of time to cause a thickening thereof, while preventing contact between the liquid or vaporized oil and the device producing the ultra-violet rays.

7. A process which comprises treating an oil substantially free from water, with ultra-violet rays, while in the form of a film, while maintained in a non-oxidizing atmosphere, and while out of contact with the device producing such ultra-violet rays, until the viscosity of said oil is increased, and the iodine number lowered.

Signed at Montclair in the county of Essex and State of New Jersey this 6th day of September A. D. 1913.

CARLETON ELLIS.

Witnesses:

B. M. ELLIS,

I. DAVID SHUBETSKI.