

H. BESSEMER.
SUGAR CANE PRESS.

No. 9,617.

Patented Mar. 15, 1853.

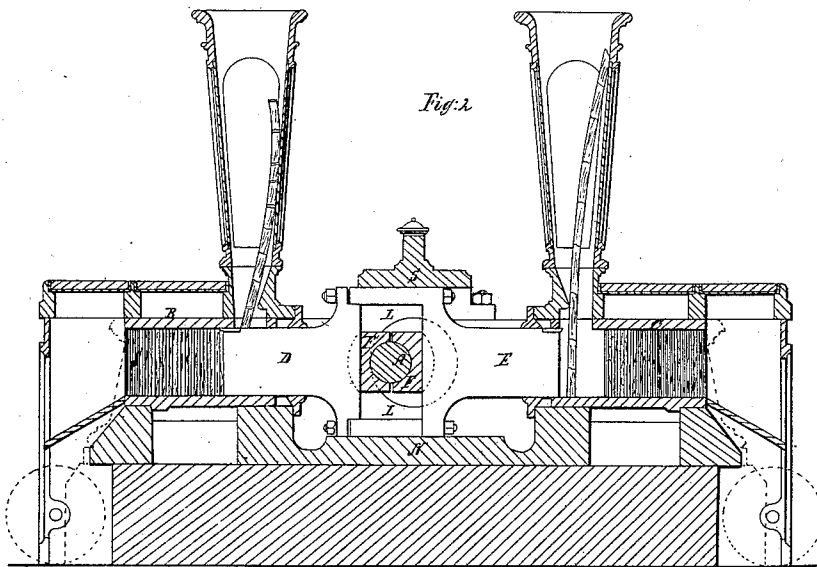
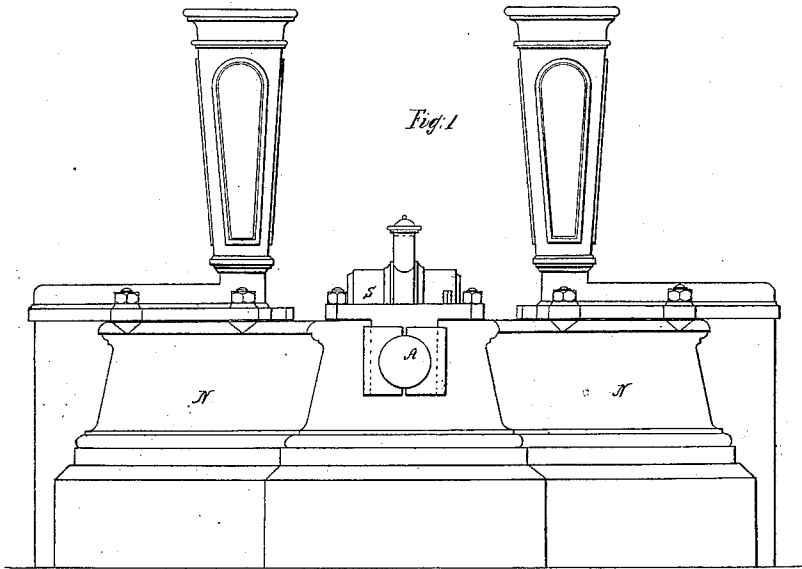

H. BESSEMER.
SUGAR CANE PRESS.

No. 9,617.

Patented Mar. 15, 1853.

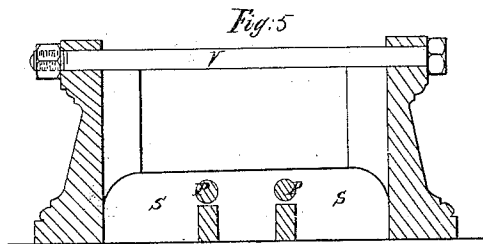
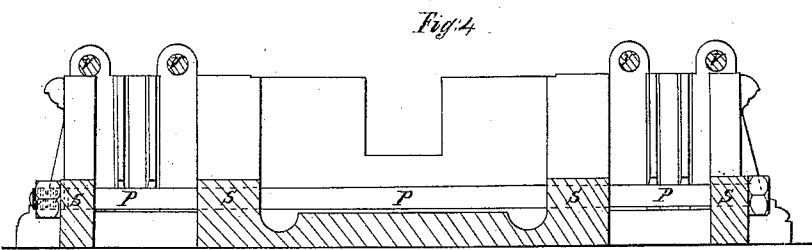
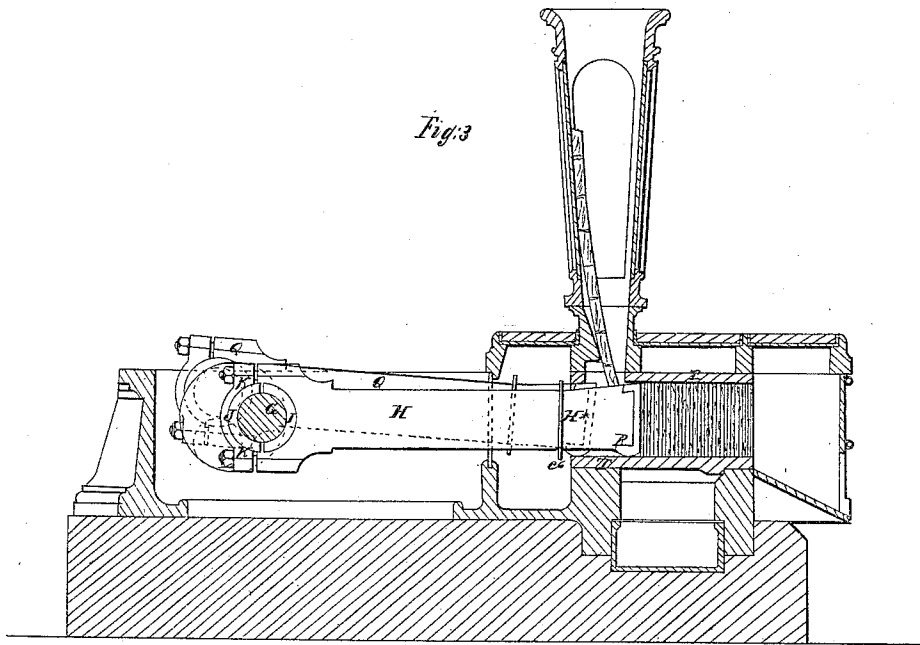

H. BESSEMER.
SUGAR CANE PRESS.

No. 9,617.

Patented Mar. 15, 1853.

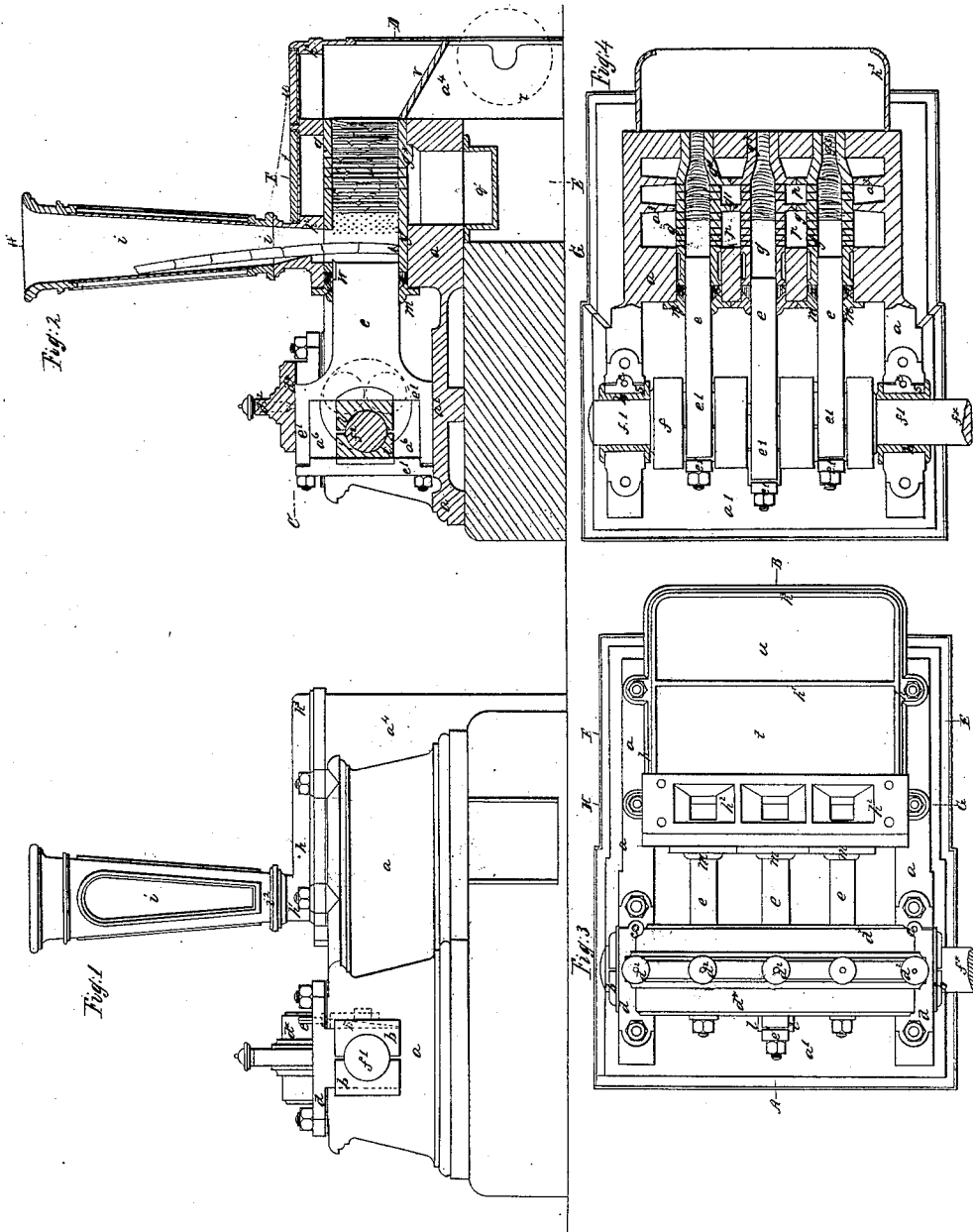

H. BESSEMER.
SUGAR CANE PRESS.

No. 9,617.

Patented Mar. 15, 1853.

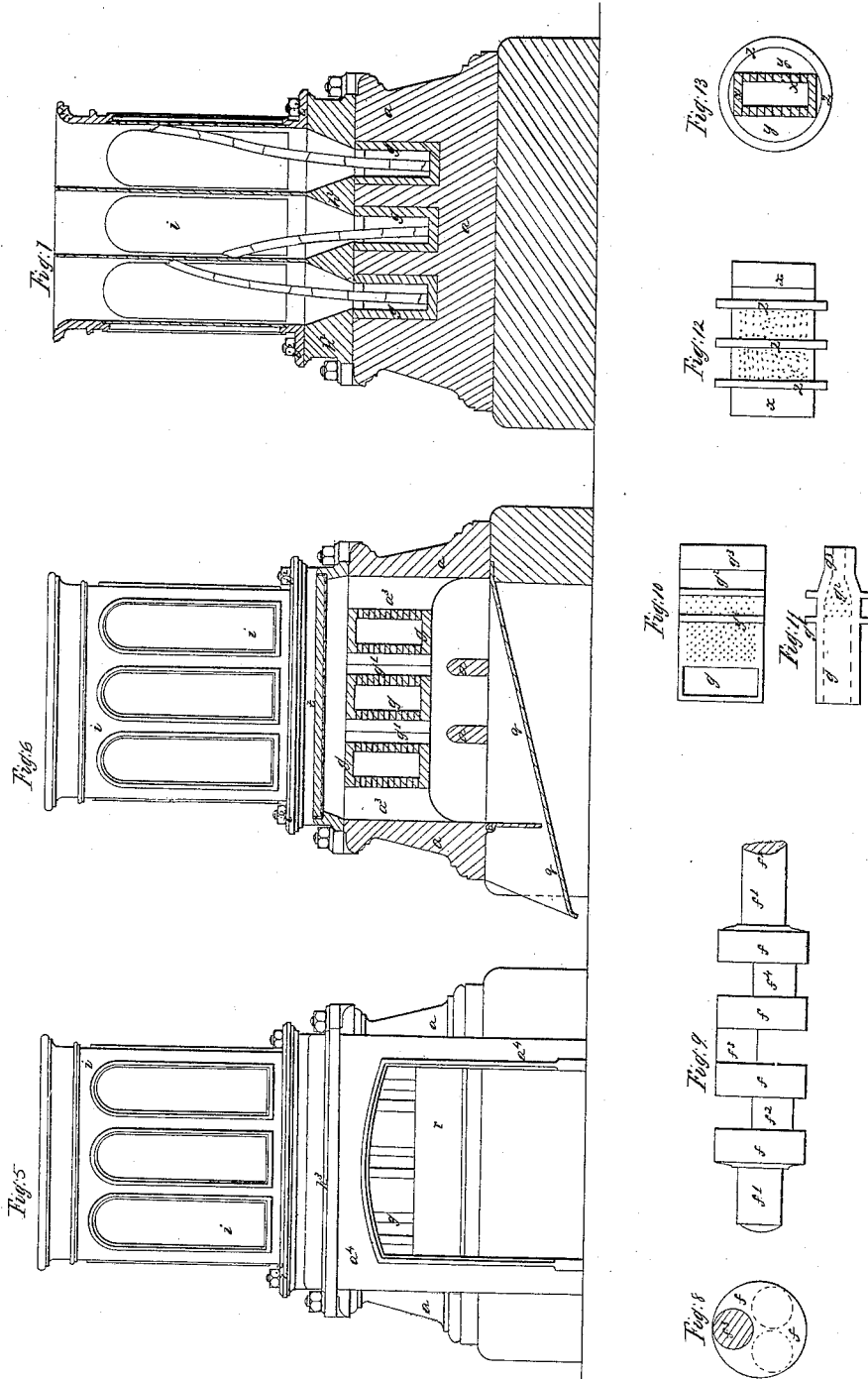

UNITED STATES PATENT OFFICE.

HENRY BESSEMER, OF BAXTER HOUSE, ENGLAND.

IMPROVEMENT IN MACHINES FOR EXPRESSING SUGAR-CANE JUICE.

Specification forming part of Letters Patent No. 9,617, dated March 15, 1853.

To all whom it may concern:

Be it known that I, HENRY BESSEMER, of Baxter House, Old Saint Pancras Road, in the county of Middlesex, England, a subject of the Queen of Great Britain, have invented or discovered new and useful Improvements in Sugar-Cane Presses; and I, the said Henry Bessemer, do hereby declare that the nature of my said invention, and the manner in which the same is to be performed, are fully described and ascertained in and by the following statement thereof, reference being had to the drawings hereunto annexed, and to the figures and letters marked thereon—that is to say:

The improvements comprehended under my said invention are represented on sheets A and B of the drawings annexed.

On sheet A, Figure 1 represents a longitudinal elevation of the improved cane-press. Fig. 2 is a longitudinal and vertical section of it, taken on the line A B of Fig. 3. Fig. 3 is a plan of the press with the hoppers removed. Fig. 4 is a horizontal section of it, taken on the line C D of Fig. 2. Fig. 5 is an end elevation of it. Fig. 6 is a vertical cross-section of it, taken on the lines E F of Figs. 2 and 3; and Fig. 7 is a vertical cross-section of it, taken on the line G H of Figs. 2 and 3.

The cast-iron frame or bed-plate *a* of the machine is cast in one piece, and has formed upon it, at opposite sides, two square recesses, into which the brass bearings *b* are fitted. These brasses are divided vertically, and have a wedge-shaped piece, *s*, (shown by dotted lines,) fitted between one of them and one side of the square recess. This wedge-shaped piece has a screw, *c*, passing through a projection formed on the back of it, by means of which the wedge is either raised or lowered into the recess, and by this means the brasses are tightened or loosened as may be required. The brasses *b* are retained in their places by flanges made on each side of them, and they are prevented from rising out of their seats by a cap, *d*, which is firmly bolted to the frame *a*. This cap is arched and rests on both sides of the frame, the central or arched part, *d*², also serving as a guide for the cane-pistons *e*. The brasses *b* are for the purpose of supporting the end journals, *f*¹, of the crank *f*. This crank I

prefer to be formed by first turning a plain cylindrical mass of iron, and then placing it eccentrically in the lathe and cutting or turning away a part of it until it is reduced about half the diameter, the reduced part forming a crank-journal. Farther on the cylindrical mass is treated in like manner in as many places as there are crank-throws to be formed thereon, each throw being placed farther round the cylindrical mass as to act in succession at equal intervals of time during each revolution of the shaft. A crank constructed in this manner is shown in elevation at Fig. 9, and in cross-section at Fig. 8. *f* is the plain cylindrical part between the throws, and *f*¹ are the journals on which it revolves. *f*², *f*³, and *f*⁴ are the crank-throws, as shown by dots in Fig. 8. The crank-shaft is shown as broken off at *f*^{*}, where it may be connected to a steam-engine or other first mover.

There are three recesses formed on the upper side of the bed-plate *a*, which are planed out so as to fit accurately the pressing-tubes *g*, which are also planed true so as to fit the said recesses in the bed-plate. By means of a rib or projection, *g*^{*}, Fig. 2, the tubes are prevented from being pushed out of their position. This projection is cast on the under side of them, and they are prevented from rising by having a cast-iron frame, *h*, bolted down to the top of the frame *a*, the cross-bar *h*¹ passing over one end of them, while at the same time the part *h*² passes across the other end, and serves also as the base of the hoppers *i*. The end *h*³ of the frame *h* overhangs the frame *a*, and has a board, *u*, fitted into it and covered with a thin sheet of copper on its under side, to protect it from the splashing of the juice. There is a similar board, *t*, fitted into the frame *h*. These boards are movable so as to afford access to the tubes. They also serve the purpose of a stage on which the feeder or attendant stands to put the canes into the hoppers *i*. The pressing-tubes *g*, respectively, have pistons or plungers *e* fitted into them. One end of each of these plungers has a recess formed in it, and a cap, *e*¹, secured by bolts in such a manner as to form a rectangular slot, *e*², in which is fitted a pair of brasses, *l l*. These brasses have flanges to keep them in place, and the brasses of the several pistons

are fitted to the eccentric parts or throws of the cranks f^2 , f^3 , and f^4 .

A portion of the bed-plate a is planed true, and between it and the under side of the piece or cap d^* , the enlarged end of the plunger is fitted, so that the space between the surfaces a' and d^* forms a guide for the plunger, and insures its rectilinear motion backward and forward when actuated by the crank. The gland m fits into a recess formed at the end of the pressing-tubes, and causes the packing n to keep a close joint, and prevent the backward flow of cane-juice, which might otherwise run down on the part a' and mix with the oil used to lubricate it. The supply of oil to these working parts is given from oil-cups d^* , which are placed above each throw of the crank, and by suitable channels the lubricating matter is allowed to flow onto the brasses and sliding parts. The hoppers i are cast in one piece, and are secured to the frame k by bolts passing through the flange i^2 .

The pressing-tubes g are each made rectangular in vertical cross-section, and as the interiors of them are difficult to plane out and render true, I prefer to cast them on an iron bar or core, which is made very accurate, and heated previously to casting the tube thereon; and as an alloy of forty parts zinc, and sixty parts of copper (known as "Muntz metal") will bear the application of force while hot much better than common brass, I prefer to make the tubes of this alloy; in order that the iron core may be forced out while the metal is hot. Otherwise the shrinking of the cast metal on the iron core would render the latter extremely difficult to be removed, and would endanger the soundness of the casting.

To prevent the bursting of the tubes by the pressure within them when in use, ribs g' are cast upon them and made to abut against each other and be sustained by similar ribs, a^3 , formed on the bed-plate a , the whole thus constituting a mutual support for each other. One of these tubes is shown in Figs. 10 and 11 detached from the rest, the said Fig. 10 being a side elevation, while Fig. 11 is a plan of the same. When rotary motion is communicated from any first mover to the crank-shaft f , and canes are put into the hoppers i , the plungers or pistons e will move forward, and the cutter w , which is fitted onto and forms the top angle of each plunger, will cut off a piece of cane equal in length to the height of the interior of its tube g . Each of the plungers e acting in succession will cut off a piece of cane and carry it forward into their respective pressing-tubes. After several pieces have been cut off in each tube the force required to push them forward through the contracted part of the tube will cause them to be crushed and flattened out, and thus still further increase the resistance which they offer to the moving-power which tends to expel them at the open end of the tube. When in this manner the

tubes are filled, the apparatus will be in a suitable condition to continue the operation of expressing the saccharine fluid from the cane.

It will be observed by reference to Fig. 2, Sheet A, that the canes, which are put into the hoppers i , fall down to the bottom of the pressing-tubes whenever the plungers are drawn back, and in their forward motion that portion of the cane which is within the tube is cut off and pushed against the mass of canes therein contained; and as it requires a great amount of force to move the mass of canes forward, the piece of cane last cut off is flattened out, whereby the cells containing the saccharine juice are burst and the juice forced out through the numerous perforations made in the tubes for that purpose; but as the cane is partly composed of solid matter, which cannot escape through these perforations, every new piece that is cut off and pressed must therefore move forward the mass a distance equal to its own thickness when in a compressed state, and thus discharge at each stroke a portion of the compressed cane or "bagasse" at the open end of the tube.

In the cane-presses heretofore made with pressing-tubes the said tubes have been made with parallel or nearly parallel surfaces throughout their interiors, and of much greater length than those of my invention, as represented in the annexed drawings. The resistance opposed to the escape of the canes through the tubes being chiefly or wholly caused by the friction of the bagasse in passing through the tube, it has been found that the elasticity of the bagasse in such a long tube tended to prevent the crushing of the cane by forming a sort of cushion for it, and it also produced an irregular action of the machine by not allowing each new portion of cane when pressed to expel another piece at the opposite end of the tube. These disadvantages are obviated in the present invention—that is to say, by forming pressing-tubes in the manner represented in the annexed drawings, and causing the resistance necessary to crush the cane by forcing the bagasse (which has once been squeezed out, so as to occupy the wider part of the tube) through the taper part g^2 thereof, and afterward forcing it along the narrow parallel part g^3 of the tube. This change of form taking place while the canes are under pressure will assist the disruption of the cells in which the juice is contained, and facilitate its removal from them, while the quantity of bagasse contained in the wide part of the tube is too small to prevent the proper crushing of the cane by its elasticity.

It will also be observed that the crank, as herein represented, will cause the pistons to act in succession, so that the great resistance opposed to the pistons during the last portion of their forward movement will have ceased in one tube before it is commenced in another, and thus much of the strain is taken off the machine by their moving one after the other,

instead of moving simultaneously, as heretofore practiced.

The spaces *p* between the supporting-ribs allow that portion of the juice which escapes laterally to fall down into the chute *g*, from whence it may be conveyed to the clarifiers.

The framing *a'* at the end of the press may be made to contain a drum, *r*, (shown by dots,) around which an endless web may be made to pass for the purpose of carrying away the bagasse, which slides down the inclined plate *v* onto it.

In order to strengthen the pressing-tubes I sometimes cast one or more circular flanges upon them, and when the edges of these flanges are turned true I shrink an iron or steel ring upon them, in a manner well understood. A tube so constructed is represented on Sheet A, where Fig. 12 is a side elevation, and Fig. 13 is a cross-section, of it. *x* is the tube; *y*, the flange cast thereon, and *z z z* the steel rings shrunk upon the tube.

In the cane-press represented on Sheet A, I have shown only three pressing-tubes; but I do not confine myself to that number, because other numbers may be used in the same manner by making the requisite number of throws upon the crank-shaft and otherwise adapting the apparatus thereto. But when it is desired to increase greatly the number of pressing-tubes, I prefer to construct a double-acting machine, which I have represented in Sheet B of the annexed drawings, where Fig. 1 is an elevation of such machine, and Fig. 2 a longitudinal vertical section of it, taken through the center of the machine. In this modification of the apparatus the crank-shaft *A* is placed across the center of it, and equidistant between two sets of pressing-tubes, *B* and *C*. The plungers *D E* are bolted end to end, and in the slot *L*, formed between them, the brasses *F* move up and down when the crank-shaft is in motion. The general details and arrangement of this apparatus are the same as that before described and represented on Sheet A, with the exception of such parts as are necessarily modified in form or position to suit its double action.

In both the forms of apparatus herein lastly described it will be seen that the plungers have their motion rendered rectilinear by working in between the bed-plate *N* and the covering-plate *S*, which extends across the frame and fits down upon them; but in some cases I prefer to dispense with these guides and connect one end of the plungers directly with the cranks, in which case I lengthen the plungers a little, in order to lessen the angle formed by their oscillation. This renders it necessary to lengthen the frame or bed-plate to a like extent, but does not otherwise greatly interfere with the general arrangement or construction of the machine. In order that this modification may be fully understood I have shown in Fig. 3, Sheet B, a longitudinal vertical section of a machine so constructed,

such section being taken through the center of the machine. In this figure *G* is the crank-shaft, and *H* one of the plungers, which latter has a pair of brasses, *J*, fitted thereto, in which the throw of the crank revolves. These brasses are tightened up by a cap, *K*, in a manner similar to that usually employed to tighten the brasses of plumber-blocks. The opposite end of the plunger has a steel piece, *L*, fastened upon it, the lower angle of which is rounded so as to slide freely on the lower side of the tube *T*. The depth of the plunger is also reduced by a gradual taper to the part *H**, where there is a thin plate of metal, *e'*, extending around it to prevent any juice that may escape from the end of the tube from splashing against the crank.

Q represents another plunger, (seen partly in elevation above the plunger *H*, and partly by dots.) As the crank revolves these plungers rise and fall at that end where they are united to the crank, while the other ends of them move within the tubes in a right line, the faces or ends of the plungers being respectively thrown slightly out of the vertical line during the time they are receding from or approaching the end of their stroke, where they become truly vertical. The great resistance which the plungers have to overcome toward the end of their stroke renders it necessary that great strength should be given to all parts of the framing, to enable it to withstand the force thus exerted upon it. The lateral pressure of the canes within the tubes must also be borne by the frame, against which the sides of the tubes abut. In order to provide most fitly against these powerful strains I sometimes make use of tension-rods of wrought-iron so placed as to bear the chief strains to which the machine is subjected. The mode of doing this will be better understood by reference to Sheet B, where Fig. 4 is a longitudinal and Fig. 5 a cross section of a frame similar to that represented in Figs. 1 and 2, Sheet B, with the exception of the tension-rods. These rods *P P* are made of wrought-iron, and of considerable strength. They are made to pass entirely through the main cross-ribs *S S* of the frame, and thereby receive the thrust of the plungers in each direction. *V V* are also similar tension-rods, which pass across the frame and prevent the lateral pressure exerted within the tube from injuring the main framing of the machine. These tension-rods have heads forged upon them at one end, and are secured at the other by screwed nuts, as shown; or they may be tightened up by colters passing through slots formed therein.

Having thus described my invention, what I claim is as follows:

1. The improvement of constructing each of the cane-pressing tubes, substantially as specified—viz., with sides made parallel some distance, for the working of the piston against them, and to approach one another toward

the mouth of discharge of the pressed cane—whereby advantages as above mentioned are gained.

2. The combination and arrangement of two cane-presses or pressing-tubes, B C, and two conjoined pistons, D E, with one revolving actuating-shaft and its mechanism, to give to their plungers or pistons a simultaneous reciprocating rectilinear motion, all as repre-

sented in Fig. 2 of Sheet B of the drawings above mentioned.

In testimony whereof I have hereunto set my signature this 30th day of December, A. D. 1852.

HENRY BESSEMER.

Witnesses.

JOSEPH MARQUETTE,
JOHN R. DARKER.