

[54] LATCH ASSEMBLY

[75] Inventor: Helmut Standke, Woodland Hills, Calif.

[73] Assignee: Consolidated Controls Corporation, Bethel, Conn.

[22] Filed: Oct. 29, 1971

[21] Appl. No.: 193,782

[52] U.S. Cl. 292/15, 292/252
 [51] Int. Cl. E05c 5/00
 [58] Field of Search..... 292/251.5, 252, 261, 292/299, 305, 144, 201, 15, 16, 75; 335/290; 24/211; 339/91 B

Primary Examiner—Richard E. Moore
 Attorney—Richard D. Mason et al.

[57] ABSTRACT

A latch assembly for a door swingable towards and away from a doorjamb comprising a pair of mechanically engageable latch means mounted on the doorjamb and movable relatively between an engaged, mechanically latched position and an unlatched position. Permanent magnet means is provided for holding mechanically latched engagement between said latch means, and electromagnet means is provided having a polarity while energized opposing said permanent magnet for overcoming the holding force thereof to cause unlatching. One of said pair of latch means includes a pair of relatively movable members with one member being fixed to the jamb and the other member movable relative thereto. Said permanent magnet means is positioned in fixed magnetic relation to the fixed member and normally attracts said movable member to a latch holding position in contact therewith. Said electromagnet means is positioned to act through a lever and repel the movable latch member away from said latched position to said unlatched position when said electromagnet means is momentarily energized.

[56]

References Cited

UNITED STATES PATENTS

3,658,370	4/1972	Wang	292/201
3,635,511	1/1972	Waller	292/251.5
1,467,782	9/1923	Englund	292/15
2,348,967	5/1944	Duby	335/290
2,584,480	2/1952	Manting	292/251.5
R23,636	3/1953	Mark et al.	292/251.5 X
2,888,290	5/1959	Pierce	292/251.5
3,312,492	4/1967	Remhof	292/201
2,593,662	4/1952	Dickinson	292/252
3,125,790	3/1964	Gaylord	292/15 X
3,475,715	10/1969	Venaleck	339/91 B X

13 Claims, 7 Drawing Figures

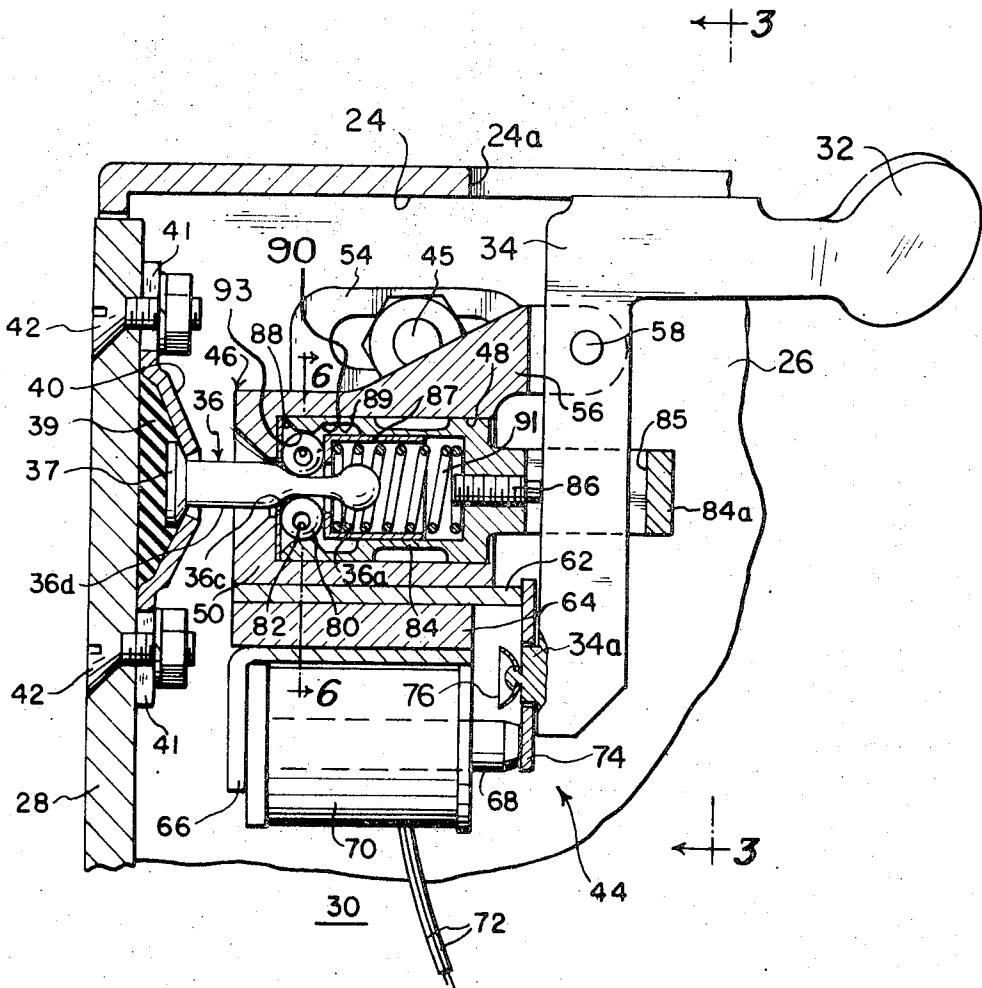

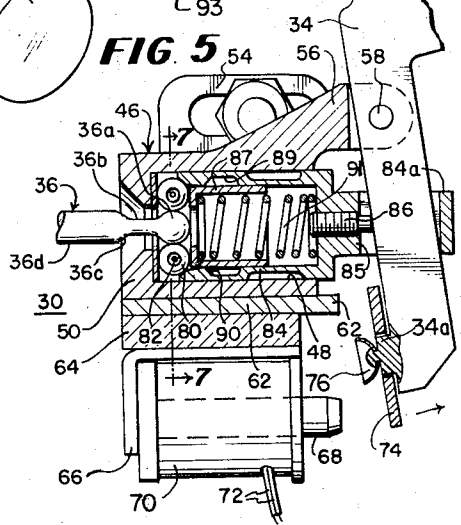
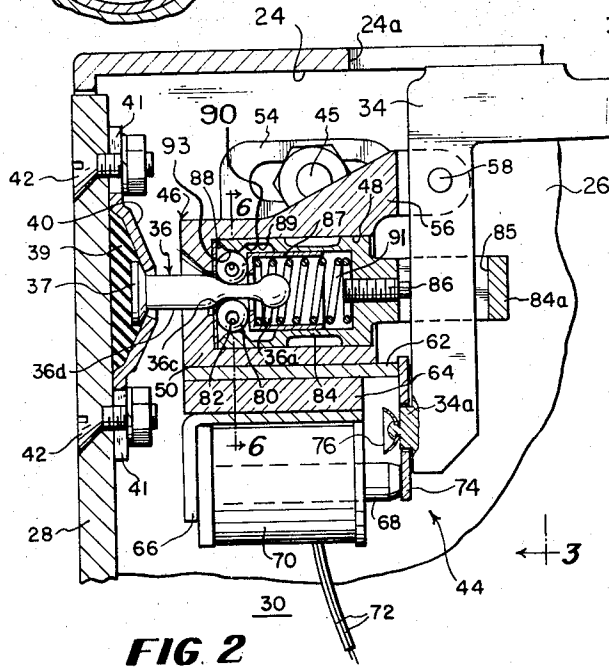
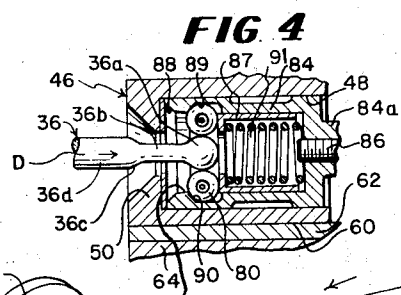
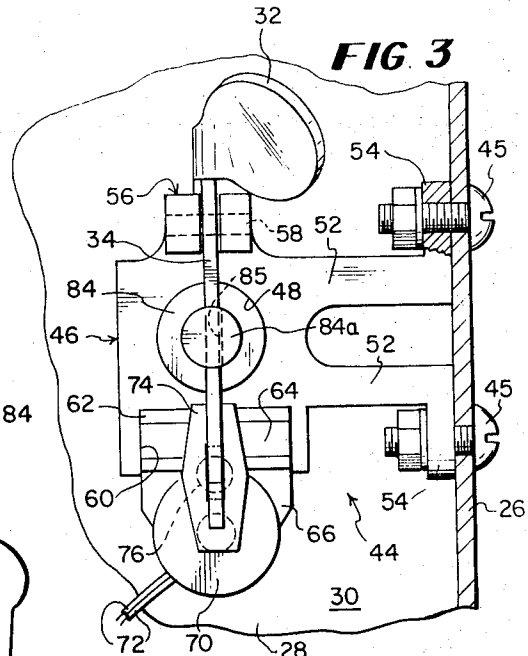
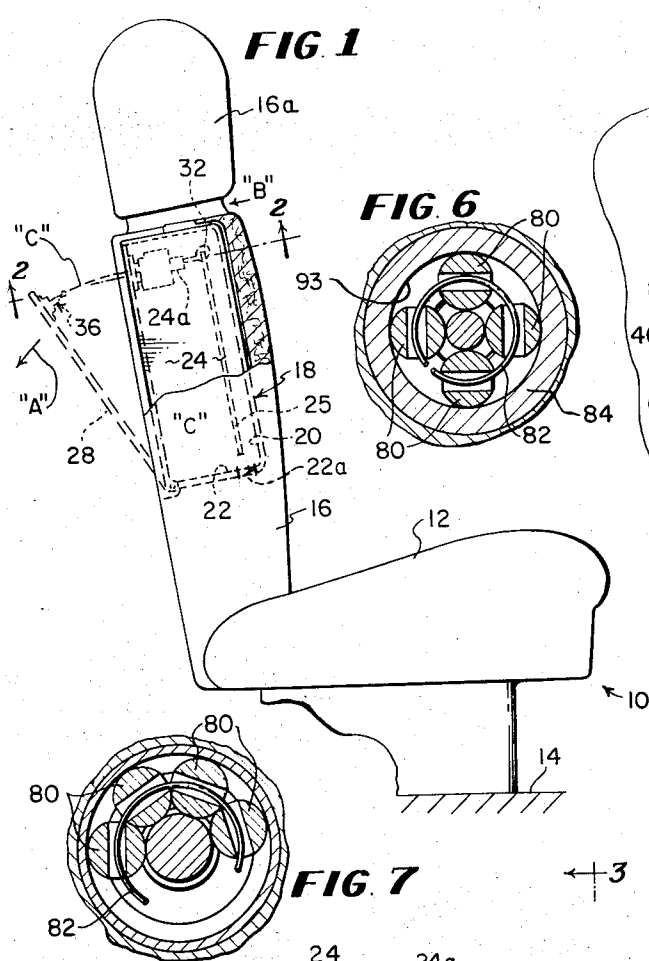

INVENTOR:
HELMUT STANDKE

BY *Mason, Kolchman, Rathbar & Wyss*
ATTORNEYS

1
LATCH ASSEMBLY

The present invention relates to a new and improved latch assembly wherein a permanent magnet force is used to hold or lock a pair of mechanically engageable latch members together in latched engagement. The magnetic latching assembly of the present invention is especially well suited for application in modern passenger aircraft for use in latching doors or closure panels on compartments carrying life support equipment, or the like. Because the doors or closure panels are only opened or unlatched under emergency conditions or during testing out of the aircraft systems, it is desirable that the latching assembly be extremely trustworthy and reliable in operation.

The latch assembly of the present invention comprises an improvement over the latch assembly shown and described in copending United States patent application Ser. No. 3,132, filed Jan. 15, 1970, now U.S. Pat. No. 3,658,370, and assigned to the same assignee as the present application. The latch assembly of the present invention is especially designed and adapted to withstand relatively high forces acting to open the door without unlatching, yet is readily unlatchable when desired by either electrical means or by manual means with very little force being required. The latch assembly employs a pair of mechanically engaged latching surfaces for maintaining the door latched in the closed position and employs a permanent magnet force for holding the latching surfaces of the latch members in latched engagement to hold the door closed. Opening of the latch assembly is normally accomplished by momentarily energizing an electromagnet to oppose the holding force of the permanent magnet, or, in the alternative, unlatching can be accomplished by manual means. In addition, the novel latch assembly of the present invention permits setting of the latch before closing of the door, with subsequent holding of the door in the closed, latched condition without requiring resetting of the latch assembly after the door is closed.

It is an object of the present invention to provide a new and improved latch assembly of the character described which employs a pair of mechanically engaged latching surfaces for holding a door in a closed, latched position with a permanent magnet force holding the pair of latching surfaces in latched engagement.

Another object of the present invention is to provide a new and improved latch assembly of the character described wherein unlocking of the engaged latch members may be accomplished either by electromagnetic means or by manual means.

Still another object of the present invention is to provide a new and improved latch assembly of the character described which can be preset in a latched condition with the door open and, subsequently, the door may be closed and latched automatically without resetting of the latch or disengagement of the latched condition.

Another object of the present invention is to provide a new and improved latch assembly of the character described which is low in cost, simple in construction, and extremely reliable and foolproof in operation.

Another object of the present invention is to provide a new and improved latch assembly of the character described which can be readily mass produced in volume quantities, yet which can meet present safety requirements of reliability of operation in an environment

2

wherein excessive forces may be applied tending to unlatch the mechanism.

Another object of the present invention is to provide a new and improved latch assembly of the character described wherein permanent magnet means is provided for maintaining latched engagement between a pair of latching members and said permanent magnet means is mounted in a fixed position relative to one of the movable latching members.

The foregoing and other objects and advantages of the present invention are accomplished in an illustrated embodiment thereof which comprises a latch assembly especially adapted for use with a door swingable toward and away from a doorjam in an environment such as a compartment in an aircraft for containing lift support equipment. The latch assembly comprises a pair of mechanically engageable latch members which are mounted on the compartment door and jamb, respectively, and which are movable relatively between an engaged, mechanically latched position and an unlatched position. Permanent magnet means is provided for maintaining the mechanically latched engagement between the pair of latch means, and electromagnet means, having a polarity while energized opposing magnetic force of the permanent magnet means, is provided for unlatching the assembly so that the compartment door may be opened. One of the latch means includes a pair of relatively movable latch members, one being fixed relative to the doorjamb and the other movable relative thereto. Said permanent magnet means is in a fixed magnetic relation to the fixed member and normally attracts the other, movable member into a latch holding position in contact therewith. Electromagnet means is positioned for repelling the other movable member out of latching engagement away from contact with the fixed means, thereby releasing the latching engagement between the latch members and permitting opening of the door.

For a better understanding of the present invention, reference should be had to the following detailed description, in which:

FIG. 1 is a side elevational view of a typical aircraft seat including a compartment mounted in the back portion of the seat for containing life support equipment for the passengers on board the aircraft;

FIG. 2 is an enlarged, fragmentary, sectional view taken on a plane through the life support compartment substantially along line 2—2 of FIG. 1 showing a latch assembly constructed in accordance with the features of the present invention in a latched condition;

FIG. 3 is a fragmentary, end, elevational view of the latching assembly looking in the direction of the arrows 3—3 of FIG. 2;

FIG. 4 is a fragmentary, sectional view of the latch assembly shown in a position wherein a latch member on the door is being moved toward latching engagement with a latch member mounted on the compartment wall;

FIG. 5 is a fragmentary view similar to FIG. 2 illustrating the latch assembly in an unlatched condition wherein the compartment door may be opened;

FIG. 6 is a transverse, fragmentary, sectional view taken substantially along line 6—6 of FIG. 2; and

FIG. 7 is a transverse, fragmentary, sectional view similar to FIG. 6 but showing the unlatched position as taken along line 7—7 of FIG. 5.

Referring now, more particularly, to the drawings, in FIG. 1 therein is illustrated a typical aircraft seat indicated generally by the numeral 10 and having a base or seat cushion 12 supported on the floor 14 of an aircraft or other vehicle. The seat includes an upstanding, sloped back portion 16 having an upper headrest 16a and the back portion is pivotally mounted on the seat or base 12 for angular adjustment therewith in order to provide for comfort of the passengers in the aircraft. In order to provide for life support equipment such as an oxygen source and an oxygen mask for the passengers in case of an emergency, an enclosure or compartment, generally indicated as 18, is mounted in the back portion of the seat.

The compartment 18 includes a front wall 20, a bottom wall 22, a pair of sidewalls 24, and a top wall 26, and one sidewall 24 serves a doorjamb structure for a swingable compartment door 28 which is hingedly attached along its lower edge to the bottom wall 22, as shown in FIG. 1. In normal conditions, the door 28 is positively latched in a closed position and forms a portion of the surface of the back portion 16 of the aircraft seat. However, in an emergency situation wherein oxygen is required, the door 28 is unlatched and pivots to the open position as shown by the arrow A (FIG. 1), so that the interior of the compartment 18 is readily accessible. Oxygen masks may be mounted on or secured to the inside surface of the door in a typical installation.

In accordance with the present invention, a new and improved latch assembly 30 is provided for positively latching and holding the door 28 in the closed position. The latch assembly normally is electrically activated to the unlatched condition for permitting the door 28 to open. If electrical actuation is not available, the door may be unlatched manually and opened. Manual opening is usually accomplished for servicing and inspection of the compartments one at a time on a seat-by-seat basis in an aircraft. Manual unlatching is accomplished by inserting a finger in between adjacent seats on the side of the seat back portions 16 in the direction indicated by the arrow B, as shown in FIG. 1, and pushing a manual unlatching tab 32 or by inserting a small tool into the interior of the compartment through an opening 22a in the wall 22 to operate an unlatching push rod 25. The actuating tab 32 is formed on the outer end of a lever 34 for releasing the latch mechanism to open the door.

In accordance with the present invention, the latch assembly 30 includes a latching stem 36 supported in cantilever fashion on the inside of the compartment door 28 adjacent the upper edge portion thereof. The stem 36 extends inwardly into the compartment 18 at the right angles to the door and includes an enlarged, washerlike base 37 which is backed up by a filler of resilient material 39. The filler 39 is carried in a dishlike annulus 40 having a circular aperture in the center thereof larger in diameter than the stem to permit limited lateral movement thereof. The baseplate 40 includes a pair of mounting lugs 41 having openings therein to accommodate washer and nut assemblies 42 or other fasteners for securing the baseplate in place on the inside surface of the door.

The stem includes an enlarged ball-type, head portion 36a at its outer end, an intermediate stem portion 36b of reduced diameter, and a frustoconically tapered portion 36c which transitions between the portion 36b to the nominal diameter of the base portion of the stem,

as at 36d. Because the stem base 37 is backed up by the resilient filler 39, the stem is movable to a limited extent and the angle between the stem and the inside surface of the door 28 may vary slightly. The enlarged diameter aperture in the mounting base 40 permits limited flexure or movement of the stem as latching engagement is made or broken. The stem moves generally in an arcuate path, as indicated by the dotted line C in FIG. 1, as the compartment door 28 is opened or closed and is adapted to cooperate with a relatively fixed, latching subassembly generally indicated as 44 (FIG. 2) which is secured to the compartment top wall 26 with mounting screws 45, or other suitable fasteners, as best shown in FIG. 3.

In accordance with the present invention, the latching subassembly 44 includes a body 46 having a hollow, cylindrical sleeve 48 which is open at the end away from the door and which is partially closed at the opposite end by an annular end flange 50 having a frustoconically tapered, concave, central aperture for guiding the stem 36 axially into the bore of the sleeve. The minimum diameter of the aperture defined by the annular flange 50 is larger than the head portion 36a of the stem in order to permit free passage of the stem into and out of axial alignment in the sleeve 48.

The latch body 46 includes a mounting base 52 having flange portions at the outer end which are apertured to receive the bolts 45 for fixedly mounting the body on the compartment wall 26. The latch body is preferably integrally formed of strong, lightweight, molded plastic material, such as polycarbonate resin and is shaped to include an upstanding, bifurcated support bracket 56 having a pivot pin 58 extended transversely through the outer end portion for pivotally supporting the latch lever 34 intermediate its ends. The latch body is formed with a recess 60 (FIG. 3) in which is mounted a pole piece 62 formed of readily magnetizable material, such as soft iron or the like. A bar-type permanent magnet 64 is mounted in the recess 60 of the body with one side in contact with the pole piece 62, and the other side of the permanent magnet contacts one leg of an L-shaped, coil supporting bracket 66 formed of soft iron or other readily magnetizable material. The L-shaped bracket includes a depending leg 66 for supporting a cylindrical, soft iron armature or coil core 68 on which is mounted an annular, electromagnetic coil indicated by the numeral 70. The electromagnetic coil is energized through a pair of color coded leads 72 in order to provide the proper magnetic polarity when the coil is energized. The coil may be provided with a diode or rectifier in series therewith for use with common aircraft power, such as a 115V, 400 Hz AC current, and the coil winding direction is chosen appropriately to achieve the desired magnetic polarity.

The latch lever 34 is preferably formed of lightweight, high strength material, such as aluminum, or the like, and is normally maintained in the latching position (as shown in FIG. 2) by magnetic force supplied by the permanent magnet 64 which attracts a lever armature 74 formed of magnetizable material, such as soft iron, mounted adjacent the lower end of the latch lever. When the latch lever is in the latched position, the lever armature 74 is in contact at its upper end with one end face of the pole piece 62, and the lower end of the armature is in contact with the exposed outer end of the coil core 68. A complete magnetic circuit is provided from the permanent magnet 64 through the pole piece

62, lever armature 74, coil core 68, and the L-shaped support bracket 66. The coil 70 is wound with a polarity so that when current is momentarily supplied through the leads 72, the magneto motive force developed is in direct opposition to the magnetic holding force developed by the permanent magnet 64. The electromagnetic force from the coil 70 is sufficiently strong relative to the permanent magnetic force supplied by the magnet 64 to cause the lever armature 74 to be repelled, and, with the help of a spring 91, moves outwardly away from the pole piece 62 and coil core 68. When this occurs, the latch lever is pivoted about the pivot pin 58 to the unlatched position, as shown in FIG. 5. Pivoting of the lever 34 from the latched position of FIG. 2 to the unlatched position of FIG. 5 may also be accomplished manually, as previously described, by actuation of the tab 32. Once the latch lever 34 is in the unlatched position and the coil 70 is subsequently de-energized, the permanent magnet 64 does not provide sufficient magnetic pull on the lever armature 74 to relatch the lever, and normally it is desirable to manually reset the lever into the latched position.

From the foregoing, it will be seen that the latch lever 34 is normally maintained or held in the latched position by magneto motive force supplied by the permanent magnet 64. When the coil 70 is energized momentarily, a strong magneto motive force in opposition to the permanent magnet force is developed and this causes the lever to pivot to the unlatched position driven by the force of a coil spring 91 and transmitted via a plunger 84 and adjustment screw 86 to the lever 34. With the coil de-energized, when it is desired to relatch the lever 34, the tab 32 is moved until the lever armature 74 is sufficiently close to the pole piece 62 to be attracted by the magneto motive force of the permanent magnet 64. Preferably, the pole piece 62, permanent magnet 64, and coil support bracket 66 are secured in position in the groove or recess 60 in the lower portion of the body 46 by means of suitable epoxy adhesive material.

The lever armature 74 is secured onto a projection 34a on the lower end of the latch lever 34 by a dished washer 76 in order to provide limited pivoting movement of the armature on the lever for good contact seating of the armature simultaneously against the facing ends of the pole piece 62 and the coil core 68. The lever armature is allowed to swivel within limits in order to provide self-aligned seating contact against the pole piece and coil core end faces, as shown in FIG. 2.

In accordance with the present invention, direct mechanical latching engagement between the stem 36 and the latching subassembly 44 is provided by a plurality of spherical latch balls 80 which are mounted at the forward end of the sleeve 48 inside the end flange 50. The balls 80 are drilled with apertures therein and are mounted on a C-ring 82 (FIGS. 6 and 7) formed of spring steel wire which normally tends to expand the balls radially outwardly to engage the walls of the sleeve. When the C-ring 82 expands and the balls 80 move radially outwardly in the sleeve to the unlatch position shown in FIGS. 5 and 7, the internal clearance in the center of the ring of latch balls is sufficiently large to permit the enlarged head portion 36a of the stem to move freely into and out of the sleeve 48 through the aperture in the end flange 50. When the balls are moved radially inwardly around the intermediate portion 36b of the stem to the latching position, as shown

in FIGS. 2 and 6, latching engagement between the balls and with the enlarged head portion 36a of the stem 36 will prevent withdrawal of the stem outwardly of the sleeve 48. In this manner, latching of the door 28 in the closed position is accomplished by mechanical means and the latching action thus provided is strong enough to resist acceleration and deceleration as much as 250 times that of gravity in a direction generally axially of the stem, tending to withdraw the stem from the sleeve 48, and as high as 300 times gravity in any other direction.

In accordance with the present invention, a generally cylindrical, hollow, cam plunger 84 is mounted for axial sliding movement in the sleeve 48. The hollow cam plunger includes an outwardly extending stem portion 84a having a vertical slot 85 formed therein. The lever 34 extends through the slot 85 and normally intersects the longitudinal axis of the cam plunger at right angles in the latched position (FIG. 2). The rearward end of the hollow cam plunger is provided with an end wall having a threaded axial bore for receiving an adjustment setscrew 86 which limits the amount of angular displacement between the latch lever 34 and the plunger, as best shown in FIG. 5. A cuplike biasing member 87 having a hollow, cylindrical sidewall and an annular flange facing the flange 50 is mounted in the bore of the cam plunger 84. The flange of the biasing member 87 is adapted to urge the latch balls 80 towards the flange 50 of the sleeve 48. The open end of the cam plunger 84 is shaped with an inwardly convex frustoconically tapered first cam surface 88 which is adapted to cam the latch balls 80 radially inwardly toward the latching position (FIG. 2) as the cam plunger is moved longitudinally in the sleeve 48 from the unlatched position of FIG. 5 to the latched position of FIG. 2.

When the cam plunger is in the latched position, the balls are maintained radially inwardly in the latched position around the intermediate portion of the stem 36b by an internal bore surface 93 (FIGS. 2 and 6) of the cam plunger 84. The bore surface is slightly tapered (approximately 7°) and is frustoconical in shape in order to compensate for friction and to aid in the release of the plunger 84 when the mechanism is unlatched under load. In this latched position, the flanged end of the biasing member 87 urges the balls toward the end flange 50 of the body and this force is supplied by a coil spring 91 mounted inside the bores of the cam plunger 84 and member 87. In this position, the latch lever 34 held by the holding force of permanent magnet 64 prevents further expansion of the bias spring 91. When, however, the magnetic holding force is overcome by energization of the coil 70, the spring 91 is effective to bias the cam plunger 84 from the latched position of FIG. 2 to the unlatched position shown in FIG. 5, and when this occurs, the frustoconical cam surface 88 on the open end of the cam plunger 84 shifts longitudinally in the sleeve, permitting the latch balls 80 to be expanded radially outwardly by the spring 82 towards the sleeve walls (FIG. 7) to the unlatched position, permitting the stem 36 to be withdrawn from the sleeve 48, as shown in FIG. 5.

When it is desired to latch the assembly, the cam plunger 84 is reset manually by movement of the latch lever 34 in a clockwise direction about the pivot pin. This forces the plunger 84 toward the flange 50 and the cam surface 88 of the plunger forces the latch balls 80

radially inwardly to the latched position of FIGS. 2 and 6. Resetting of the cam plunger 84 to the latched position may be accomplished while the door 28 is open or closed, and in the latter condition the latch balls are urged radially inwardly around the intermediate portion of the stem 36b, as shown in FIG. 2. If the compartment door is open when the cam plunger 84 is reset, the permanent magnetic holding force supplied by the permanent magnet 64 through the pole piece 62, bracket 66, and the coil core 68 holds the lever armature 74 in the latched position against the force of the bias spring 91. In this position, the latch balls 80 are maintained in the latched position of FIG. 2. Subsequently, when the compartment door is closed, the enlarged head portion 36a of the stem is forced inwardly into the sleeve 48 in the direction of the arrow D (FIG. 4). As this occurs, the stem head 36a moves the balls 80 axially within the bore of the cam plunger against force of the spring 91 exerted on the biasing member 87. During the axial movement of the balls, as the door is closed, the balls are also permitted to move radially outwardly in the bore into an internal, annular recess 89 (FIG. 4), and in this position the head portion of the stem 36a passes by the balls until the intermediate portion 36b of reduced diameter is adjacent the balls in the recess 89.

After the enlarged head portion 36a of the stem passes by the ring of latch balls which are forced radially outwardly thereby, the spring 91 is effective to bias the member 87 toward the plunger 50 and urge the balls 80 axially toward the flange and inwardly around the intermediate portion of the stem 36b to the latched position. A second, frustoconically tapered, cam surface designated as 90 is spaced axially inwardly of the convex cam surface 88 and has a slope in the opposite direction for effecting the aforescribed action. Engagement of the balls 80 against the cam surface 90 drives the balls radially inwardly into the latched position of FIG. 2, wherein the slightly tapered bore surface 93 (FIG. 6) maintains the latching engagement. From the foregoing, it will be seen that latching assembly 30 may be reset when the door is either open or closed and, once reset, with the door open, the door can be subsequently closed and latching occurs automatically without necessitating further release and reset of the mechanism. The spring 91 is of sufficient strength to move the cam plunger 84 to the unlatched position whenever the lever armature 74 is moved a slight distance away from the holding end face of the pole piece 62 and coil core 68. The permanent magnetic holding force is not strong enough to hold the lever in the latched position, once a slight gap is established. When this occurs, the latch lever pivots sharply in a counterclockwise direction about the pivot pin 58 to the unlatched position. Accordingly, when the electromagnetic coil 70 is momentarily energized, it provides a magnetic force in opposition to the force of the permanent magnet 64 nullifying the permanent magnetomotive holding force and allowing the lever armature 74 to move away from the coil core and pole piece, because the spring 91 is then rendered effective to unlatch the lever permitting axial movement of the cam plunger 84 in the sleeve 48 and movement of the latch balls 80 to the unlatched position.

The latching assembly 30 of the present invention is extremely reliable and foolproof in operation and can be unlatched either manually or electrically. In addition, the latch can be reset with the door either open

or closed and if reset while the door is open, subsequent closing of the door automatically effects latching and does not require further unlatching and resetting of the latch. The mechanical latching engagement between the enlarged head of the stem 36a and the locking balls 80 is sufficiently strong to withstand extremely high forces in a direction tending to open the door 28. The magnetic holding force of the permanent magnet 64 is used for normally maintaining the latch lever 34 in the latched position. The permanent magnet provides a magnetic holding force for securing the door in a closed position against opening forces applied to the stem 36 which are as high as 25 times the amount of the holding force at the lever armature 74.

While there has been illustrated and described a single embodiment of the present invention, it will be appreciated that numerous changes and modifications will occur to those skilled in the art, and it is intended in the appended claims to cover all those changes and modifications while fall within the true spirit and scope of the present invention.

What is claimed as new and desired to be secured by Letters Patent of the United States is:

1. A latch assembly for a door swingable toward and away from a doorjamb, said latch assembly comprising a pair of mechanically engageable latch means mounted on said door and jamb, respectively, and movable relatively between an engaged mechanically latched position and an unlatched position, permanent magnet means for retaining said mechanically latched engagement between said latch means while in said latched position, electromagnet means having a polarity while energized opposing said permanent magnet means for overcoming the retaining force thereof for unlatching movement of said latch means to said unlatched position permitting said door to be opened, one of said latch means including a pair of relatively movable members, one member fixed relative to said jamb and the other movable relative thereto, said permanent magnet means in fixed magnetic relation to said fixed member and normally attracting said movable member to a latch holding position in contact therewith, said electromagnet means positioned to repel said movable member away from contact with said permanent magnet means to a latch releasing position when said electromagnet means is momentarily energized, said movable member including a lever mounted for pivotal movement relative to said fixed member toward and away from said permanent magnet, said permanent magnetic force normally biasing said lever toward said latch holding position, said movable member including a latch subassembly connected to said lever and movable to engage and release said other latch means, said lever including a magnetic armature means engageable with said permanent magnet means and a pole face of said electromagnet means in said latch holding position.

2. The latch assembly of claim 1 wherein said subassembly includes spring means for biasing said lever away from said latch holding position against the magnetic holding force of said permanent magnet means.

3. The latch assembly of claim 1 wherein the other of said latch means includes an elongated stem supported at one end in cantilever fashion and an enlargement mounted adjacent the outer free end of said stem for latching engagement with said one latch means when in said mechanically engaged latched position.

4. The latch assembly of claim 3 wherein said enlargement comprises a spherical ball mounted on said stem, said stem being laterally flexible adjacent said outer free end and movable toward and away from said one latch means upon opening and closing of said door into and out of latching engagement therewith.

5. The latch assembly of claim 3 wherein said fixed member comprises socket forming means including a plurality of circumferentially spaced latching balls movable radially of the axis of said stem into and out of latching engagement with said enlargement on said stem and means for moving said balls into and out of latching engagement with said enlargement.

6. The latching assembly of claim 5 wherein said socket forming means includes a hollow sleeve for containing said balls and a cam plunger mounted for axial sliding movement relative to said sleeve permitting radial movement of said balls in response to the axial position thereof, said permanent magnet means normally urging said plunger into an axial position wherein said balls are urged into latched engagement around said stem.

7. The latching assembly of claim 6 wherein the force exerted by said electromagnet means while energized is active to move said plunger into a second axial position permitting said balls to move radially outward out of latched engagement with said enlargement.

8. The latch assembly of claim 6 including a lever pivotally mounted with respect to said sleeve and connected to move said plunger therein, said permanent magnet means positioned to exert bias on said lever normally maintaining said plunger in said sleeve in a latching position urging said balls into latching engagement around said stem.

9. The latch assembly of claim 8 wherein said lever carries a magnetic armature thereon and said electromagnet means includes a pole piece in magnetic circuit with said permanent magnet means, said lever armature adapted to magnetically interconnect one end of said pole piece and said permanent magnet means for holding said plunger in a latching position, said electromagnet means operable to repel said lever armature away from said pole piece upon energization to move

said plunger to an unlatch position.

10. A latching assembly including a hollow sleeve having an inwardly directed annular flange at one end defining an axial opening; a latch stem having an enlarged head on a free outer end and movable axially into and out of said sleeve through said opening for latching engagement therein; a plurality of retaining balls in said sleeve adjacent said flange for controlled latching engagement with said enlarged head of said stem; a cam plunger slidable in said sleeve including a first surface for camming said balls inwardly toward a latching position around said stem; a second oppositely sloping cam surface spaced axially of said first for urging said balls inwardly into said latching position, means for biasing said balls axially of said plunger toward said flange, and holding means including a permanent magnet for normally maintaining said plunger in a first axial position in said sleeve wherein said balls are urged inwardly into a latching position around said stem whereby withdrawal of said stem from the socket is prevented by engagement between said balls and said enlarged head.

11. The latching assembly of claim 10 wherein said second cam surface defines a wall portion of an annular recess internally of said plunger for receiving said balls in an unlatched position permitting passage of said head thereby upon axial movement of said stem into said socket.

12. The latching assembly of claim 10 including electromagnet means having a polarity when energized opposing said permanent magnet for activating said holding means to move said plunger axially in said socket to a ball releasing position wherein said balls are movable outwardly away from said stem.

13. The latching assembly of claim 10 wherein said plunger includes a third internal cam surface of gently tapered frustoconical shape for supporting said balls in latched position around said stem, said third cam surface compensating for friction between said stem head, said balls and said plunger allowing said plunger to move toward a stem head releasing position when axial load is applied to unlatch said stem.

* * * * *

45

50

55

60

65