



(11) **EP 1 570 765 B1**

(12) **EUROPEAN PATENT SPECIFICATION**

(45) Date of publication and mention
of the grant of the patent:
14.05.2008 Bulletin 2008/20

(51) Int Cl.:
A47B 77/02 ^(2006.01) **A47B 77/06** ^(2006.01)
A47B 96/06 ^(2006.01)

(21) Application number: **04004963.7**

(22) Date of filing: **03.03.2004**

(54) **Modular kitchen system**

Modulares Küchensystem

Système de cuisine modulaire

(84) Designated Contracting States:
DE ES FR GB IT PL

(43) Date of publication of application:
07.09.2005 Bulletin 2005/36

(73) Proprietor: **WHIRLPOOL CORPORATION**
Benton Harbor
Michigan 49022 (US)

(72) Inventors:
• **Cusinato, Alessia**
21025 Comerio (IT)
• **Menegon, Renzo**
21025 Comerio (IT)

• **Willemen, Maurits**
21025 Comerio (IT)

(74) Representative: **Guerci, Alessandro**
Whirlpool Europe S.r.l.
Patent Department
Viale G. Borghi 27
21025 Comerio (VA) (IT)

(56) References cited:
EP-A- 0 363 868 **DE-A- 10 235 776**
US-A- 3 101 486 **US-A- 3 899 228**
US-A- 5 392 934

EP 1 570 765 B1

Note: Within nine months from the publication of the mention of the grant of the European patent, any person may give notice to the European Patent Office of opposition to the European patent granted. Notice of opposition shall be filed in a written reasoned statement. It shall not be deemed to have been filed until the opposition fee has been paid. (Art. 99(1) European Patent Convention).

Description

[0001] The present invention relates to a modular kitchen system, and more particularly to a system for interconnecting a plurality of modular kitchen units along a common base structure.

Background of the Invention

[0002] In the majority of kitchen constructions, the fabrication and assembly of the kitchen is performed as a plurality of steps by skilled kitchen installers. Plumbing layout and electrical wiring are often done prior to cabinet construction or installation. This is then followed by the installation of appliance units - ovens, dishwashers, refrigeration units. In some cases, it is necessary for plumbers to return after the appliances are installed to make water, drain and electrical connections to the appliances. The process of assembly a kitchen is relatively complex and labour intensive.

[0003] In order to reduce this complexity and simplify kitchen installation, it would be beneficial to develop a modular kitchen system wherein a plurality of storage, appliance and/or sink modules may be quickly assembled together to provide an attractive, functional and cost effective kitchen system.

[0004] The desirability of a modular kitchen system has been previously recognized as illustrated by U.S. Pat. Appl. No. 2003/0227240 A1 which describes a modular, vertically adjustable kitchen system having modular appliance units and modular base units for vertically adjusting the modular appliance units. U.S. Des. Pat. No. Des. 313,727 discloses an ornamental appearance of a kitchen work unit where it appears that a number of appliances and storage units are integrated into a common unit.

[0005] U.S. Pat. No. 5,513,908 discloses a modular system for assembling food service fixtures including a horizontal wall mounted rails having a number of leg assemblies fastened thereto. Different fixtures or modules - warmers, control panels, shelves - can be fastened between adjacent leg assemblies.

[0006] U.S. Pat. No. 5,392,934 discloses a wall rail apparatus being used in a kitchen, providing adjustable support for various kitchen structures side-by-side.

[0007] Regardless of the existence of prior proposed systems, there lacks a complete modular kitchen system where a plurality of different modules, including sink modules, may be connected together and easily provided with utilities.

Summary of the Invention:

[0008] According to the invention, a modular kitchen system is provided having a plurality of modular kitchen units assembled together and mounted to a kitchen wall. The plurality of modular units include at least a sink unit and an appliance unit. A mounting rail is mounted to the kitchen wall, the mounting rail being an elongated ele-

ment having an upper portion and a lower portion. A movable water tap is slidably supported along the upper portion of the mounting rail. A plurality of mounting brackets slidably connect to the mounting rail and include collar-like main bodies for supporting the plurality of modular units wherein the plurality of units include contiguous ends that substantially match each other and may be received into one of the collar-like main bodies of the mounting brackets for support along the mounting rail.

[0009] The plurality of modular units may include at least a sink unit, a refrigeration unit, and a cooking unit. The mounting rail houses a plurality of utility conduits for supplying power and water to the modular units.

[0010] The modular kitchen assembly may further include a hood member extending from the upper portion of the mounting rail which is formed by a pair of frame elements extending upwardly from the mounting rail for supporting a hood cover. Electrical power is supplied to a light element mounted within the hood cover through one of the pairs of frame elements and a switch is provided on the mounting rail for controlling energization of the light element.

Brief Description Of The Drawings

[0011] The present invention will be more apparent from the accompanying drawings, which are provided by way of non-limiting example and in which:

FIG. 1 is a perspective view of a modular kitchen system embodying the principles of the present invention.

FIG. 2 is an exploded, perspective view of the modular kitchen system of FIG. 1 but without the modular appliance units.

FIG. 3 is a sectional view taken along lines 3-3 of FIG. 2.

FIG. 4 is a sectional view of an alternate embodiment of the mounting rail.

FIG. 5 is a perspective view of one of the modular units and associated mounting brackets.

FIG. 6 is a perspective view of the modular kitchen system of the present invention with surrounding kitchen cabinetry.

Detailed Description Of The Preferred Embodiments

[0012] With reference to FIG. 1, an overall modular kitchen system constructed in accordance with the present invention is generally indicated at 10. As shown, the kitchen system includes a wall assembly which includes a plurality of modules such as a sink unit 12, a refrigeration unit 14, and an cooking unit 16 which extend from a kitchen wall surface 20. The refrigeration unit 14 and cooking unit 16, may be each referred to as appliance units. Appliance units may also refer to a dishwasher type unit or even an automatic washer type unit. While these units or modules are shown, it can be readily understood

that other modules may be incorporated into this modular kitchen system including storage units. All of these units or modules are constructed and assembled together in accordance with the present invention as described more fully below.

[0013] The different units or modules 12, 14, 16 are mounted to the wall 20 through use of a mounting rail 30, as shown in FIG. 2. The mounting rail 30 is a multi-functional member which serves to provide: structural support to the appliance units 12, 14 and 16; a mechanism to supply utilities to the appliance units 12, 14 16; support for a lighting/hood member 24; support to a movable or slidable water tap 26; and finally, a rear portion of the work surface formed by the appliance modules. The mounting rail 30 is securely mounted to the wall 20 through the use of known fastening techniques.

[0014] The mounting rail 30 is an elongated member having an upper portion 32 and a lower portion 34. The upper portion 32 includes a top surface 36 which forms part of the work surface of the kitchen assembly 10 and also provides a support for the slidable water tap 26. A vertically extending back splash portion 37 may extend from the top surface 36 upwardly along the wall 20. The back splash may be integrally part of the mounting rail or a separate member. The slidable water tap 26 is located in a guide or slot 38 and is connected to a flexible hose 40 such that the tap 26 may be allowed to move longitudinally along the kitchen system 10. In this way the tap 26 may be located above the sink unit 12 or above the cooking unit 16 for filling a cooking vessel with water or along any other section of the kitchen system 10.

[0015] The lower portion 34 of the rail 30, best shown in FIG. 3, may house a plurality of utility conduits - such as a water inlet 42 and a power or electricity inlet 44. Further, a drain outlet conduit 46 may be provided. At predetermined locations, inlet pipes 43 and 45 for water inlet and power are provided teed off from the utility conduits 42 and 44 for connection with appliance or sink units 12, 14, 16. Moreover, a drain tube 47 may also be teed off from the drain outlet conduit 46. In this way, appliance units 12, 14 and 16 may be mounted to the rail 30 and also readily connected to the necessary utilities. The rail 30, when mounted to the wall 20, is connected to external utilities at one location and then distributes these utilities along the lower portion. The utility conduits may also be housed in the upper portion 32.

[0016] The mounting rail 30 may be a unitary structure or may be constructed from a plurality of separate parts. FIG. 4 illustrates an alternative embodiment of the mounting rail 30' where the rail is separated into two elements. In this embodiment, the rail 30' includes a first upper member 32' and a lower member 34'. The upper member 32' supports a movable water tap 26 and houses a plurality of utility inlet pipes 43', 45' that extend from the utility conduits 42 and 44. The lower member 34' houses a drain tube 47' which extends from a drain outlet conduit 46 - in a similar manner as described above.

[0017] One of the functions of the mounting rail 30 is

to support the modular units 12, 14, 16 and to that end, the mounting rail 30 includes a guide channel 50, as shown in FIG. 3. The guide channel 50 extends along the length of the mounting rail 30 and provides an engagement location for a plurality of mounting brackets 52 which are slidably received onto the mounting rail 30 in a manner wherein an engagement portion 54 is received into the guide channel 50 (see FIG. 3). The mounting brackets 52 may be preferably formed from metallic material such as stainless steel or aluminum. The mounting brackets include a collar-like main body 56 that is positioned between the contiguous ends of adjacent modular units 12, 14, 16 for supporting the units. Shown in greater detail in FIG. 5, the collar-like main body 56 receives the end 58 of a unit. The unit end 58 may be formed with a recessed portion 58a to nest or fit within the collar-like main body 56. Additionally, the collar-like main body 56 may be provided with a mechanism (not shown) for tightening the main body 56 about the end 58 of the unit.

[0018] FIG. 4 illustrates an alternate embodiment of the mounting brackets 52. In this embodiment, mounting brackets 70 are formed as reverse C shaped members. A collar-like main body 72 includes two engagement ends 74 and 76. These engagement ends are received into a pair of guide channels 80 and 82 provided on the mounting rail 30'. Additionally, it can be seen that a support leg 77 may extend downwardly from one or more of the mounting brackets 70 to provide further support for the modular units.

[0019] Located at either end of the modular kitchen system 10 is a final mounting bracket 52 and an end panel 110, 112. The end panels are design to assemble to the end mount bracket 52 and provide a finished visual appearance.

[0020] Looking again at FIGS. 1 and 2, it can be seen that mounting rail 30 further supports a lighting hood member 24. The hood member 24 includes a pair of upwardly extending frame elements 86 and 88 which support the hood cover 90. The hood cover 90 may support a light element 92. The power supply to the light element 92 is provided through one of the frame elements. A control switch 94 may be provided along the top surface 36 of the mounting rail 30.

[0021] As discussed above, the modular kitchen system may include a sink unit 12, a refrigeration unit 14, and a cooking unit 16. The individual units include end portions 58 that may be received into the main body 56 of the mounting brackets 52. Moreover, each end 58 of the units 12, 14, 16 substantially conform to a fixed shape or configuration so that the individual units 12, 14, 16 may be assembled both in any desired order. Moreover, by utilizing different length mounting rails 30, it is also possible to utilize different numbers of units.

[0022] In FIG. 1 it is shown that the refrigeration unit 14 may comprise a drawer element 98 which includes two cavities 100 and 102 that may be varied in size by movement of a middle divider element 104. The two cavities 100 and 102 are a fresh food cavity and freezing

cavity respectively. By adjusting the location of the middle divider 104, the size of the cavities can be varied. Moreover, the top surface 106 of the refrigeration unit 14 may be a transparent material such that it is possible to view the contents of the refrigeration unit 14 without opening the drawer element 98.

[0023] The cooking unit 16 may be provided with a cooktop surface 108 which includes a plurality of heating element (not shown). Below the cooktop surface 108, there is an oven cavity which can be either a conventional oven cavity or a microwave. As previously discussed, it is possible to move the water tap 26 to directly fill cooking vessels located on the cooktop surface.

[0024] It can be seen that the top surface of the modular kitchen system 10 is formed from a combination of the modular appliance units 14, 16, along with the top surface 36 of the mounting rail 30. Together, these elements form the top work surface of the modular kitchen system 10 such that no additional counter top material or structure is required.

[0025] Turning now to FIG. 6, the modular kitchen system 10 of the present invention is shown incorporated into a kitchen environment with additional storage units and work surface areas. In this way, the space around and below the modular kitchen system 10 may be beneficially used.

[0026] As is apparent from the foregoing specification, the invention is susceptible of being embodied with various alterations and modifications which may differ particularly from those that have been described in the preceding specification and description. It should be understood that we wish to embody within the scope of the patent warranted hereon all such modifications as falling within the scope of the claims.

Claims

1. A modular kitchen system having a plurality of modular kitchen units (12, 14, 16) assembled together and mounted to a kitchen wall, the plurality of modular units (12, 14, 16) include at least a sink unit (12) and an appliance unit (14, 16), wherein a mounting rail (30) is mounted to the kitchen wall, the mounting rail (30) being an elongated element having an upper portion (32) and a lower portion (34), **characterized by** a movable water tap (26) slidably supported along the upper portion (32) of the mounting rail, a plurality of mounting brackets (52) which slidably connect to the mounting rail (30) and include collar-like main bodies (56) for supporting the plurality of modular units (12, 14, 16) wherein the plurality of units include contiguous ends that substantially match each other and may be received into one of the collar-like main bodies of the mounting brackets for support along the mounting rail.
2. The modular kitchen assembly as claimed in claim 1, **characterized in that** the plurality of modular units (12, 14, 16) include at least a sink unit (12), a refrigeration unit (14) and a cooking unit (16).
3. The modular kitchen assembly as claimed in claim 1, **characterized in that** the mounting rail (30) houses a plurality of utility conduits (42, 44) for supplying power and water to the modular units (12, 14, 16).
4. The modular kitchen assembly as claimed in claim 1, **characterized in that** the mounting rail (30) is formed from an upper member (32') and a separate lower member (34').
5. The modular kitchen assembly as claimed in claim 4, **characterized in that** the upper member (32') houses a plurality of utility conduits (42, 44) for supplying power and water to the modular units (12, 14, 16).
6. The modular kitchen assembly as claimed in claim 1, **characterized in that** a hood member 24 extends from the upper portion (32) of the mounting rail (30).
7. The modular kitchen assembly as claimed in claim 6, **characterized in that** the hood member (24) is formed by a pair of frame elements extending upwardly from the mounting rail (30) for supporting a hood cover (90).
8. The modular kitchen assembly as claimed in claim 7, **characterized in that** electrical power is supplied to a light element (92) mounted within the hood cover (90) through one of the pairs of frame elements and a switch (94) is provided on the mounting rail (30) for controlling energization of the light element.
9. The modular kitchen assembly as claimed in claim 1, **characterized in that** the modular kitchen system includes a top work surface formed by a combination of the modular units and the upper portion of the mounting rail.
10. The modular kitchen assembly as claimed in claim 9, **characterized in that** the plurality of modular units (12, 14, 16) include at least a sink unit (12) and a refrigeration unit (14) and wherein the refrigeration unit includes a drawer (98) and a transparent top surface (106).
11. The modular kitchen assembly as claimed in claim 10, **characterized in that** the plurality of modular units (12, 14, 16) also include a cooking unit (16) upon which cooking vessels may be placed and the movable water tap (26) may be slidably positioned adjacent the cooking unit for supplying water to such cooking vessels.

Patentansprüche

1. Modulares Küchensystem mit einer Vielzahl von modularen Kücheneinheiten, (12, 14, 16), die zusammengesetzt und an einer Küchenwand befestigt sind,
wobei die Vielzahl von modularen Einheiten (12, 14, 16) zumindest eine Spüleneinheit (12) und ein Geräteeinheit (14, 16) beinhaltet, und wobei eine Befestigungsschiene (30) an der Küchenwand befestigt ist, wobei die Küchenwand (30) ein längliches Element ist, das einen oberen Abschnitt (32) und einen unteren Abschnitt (34) aufweist, **gekennzeichnet durch** eine bewegliche Wasserleitung (26), die gleitbar entlang des oberen Abschnitts (32) der Befestigungsschiene abgestützt ist, eine Vielzahl von Befestigungshalterungen (52), die gleitbar mit der Befestigungsschiene (30) verbunden sind und kragenähnliche Hauptkörper (56) zum Abstützen der Vielzahl von modularen Einheiten (12, 14, 16) beinhalten, wobei die Vielzahl von Einheiten benachbarte Enden beinhaltet, die im Wesentlichen miteinander zusammenpassen und in einem der kragenähnlichen Hauptkörper der Befestigungshalterungen zum Abstützen entlang der Befestigungsschiene aufgenommen werden können.
2. Modularer Küchenaufbau wie in Anspruch 1 beansprucht, **dadurch gekennzeichnet, dass** die Vielzahl von modularen Einheiten (12, 14, 16) zumindest eine Spüleneinheit (12), eine Kühleinheit (14) sowie eine Kocheinheit (16) beinhalten.
3. Modularer Küchenaufbau wie in Anspruch 1 beansprucht, **dadurch gekennzeichnet, dass** die Befestigungsschiene (30) eine Vielzahl von Versorgungsleitungen (42, 44) zur Zufuhr von Energie und Wasser zu den modularen Einheiten (12, 14, 16) einhaust.
4. Modularer Küchenaufbau wie in Anspruch 1 beansprucht, **dadurch gekennzeichnet, dass** die Führungsschiene (30') aus einem oberen Element (32') und einem separaten unteren Element (34') ausgebildet ist.
5. Modularer Küchenaufbau wie in Anspruch 4 beansprucht, **dadurch gekennzeichnet, dass** das obere Element (32') eine Vielzahl von Versorgungsleitungen (42, 44) zur Zufuhr von Energie und Wasser zu den modularen Einheiten (12, 14, 16) einhaust.
6. Modularer Küchenaufbau wie in Anspruch 1 beansprucht, **dadurch gekennzeichnet, dass** ein Haubenelement (24) sich von dem oberen Abschnitt (32) der Befestigungsschiene (30) erstreckt.
7. Modularer Küchenaufbau wie in Anspruch 6 beansprucht, **dadurch gekennzeichnet, dass** das Haubenelement (24) aus einem Paar von Rahmenelementen ausgebildet ist, die sich von der Befestigungsschiene (30) zum Abstützen einer Haubenabdeckung (90) nach oben erstrecken.
8. Modularer Küchenaufbau wie in Anspruch 7 beansprucht, **dadurch gekennzeichnet, dass** die elektrische Energie an einem Beleuchtungselement (92) innerhalb der Haubenabdeckung (90) befestigt ist, durch eins der Paare von Rahmenelementen zugeführt wird, und dass ein Schalter (94) an der Befestigungsschiene (30) zur Steuerung der Energieversorgung für das Beleuchtungselement vorgesehen ist.
9. Modularer Küchenaufbau wie in Anspruch 1 beansprucht, **dadurch gekennzeichnet, dass** das modulare Küchensystem eine obere Arbeitsoberfläche beinhaltet, die durch eine Kombination der modularen Einheiten und des oberen Abschnitts der Befestigungsschiene ausgebildet ist.
10. Modularer Küchenaufbau wie in Anspruch 9 beansprucht, **dadurch gekennzeichnet, dass** die Vielzahl von modularen Einheiten (12, 14, 16) zumindest eine Spüleneinheit (12) und eine Kühleinheit (14) beinhaltet, wobei die Kühleinheit ein Schubfach (98) und eine transparente obere Oberfläche (106) beinhaltet.
11. Modularer Küchenaufbau wie in Anspruch 10 beansprucht, **dadurch gekennzeichnet, dass** die Vielzahl von Einheiten (12, 14, 16) auch eine Kocheinheit (16) beinhaltet, auf der Kochbehältnisse platziert werden können, und dass die bewegliche Wasserleitung (26) gleitend benachbart zur Kocheinheit zur Zufuhr von Wasser zu den Kochbehältnissen positioniert sein kann.

Revendications

1. Système de cuisine modulaire comprenant une pluralité d'unités de cuisine modulaires (12, 14, 16) assemblées ensemble et montées sur une paroi de cuisine,
la pluralité d'unités de cuisine modulaires (12, 14, 16) comprend au moins une unité d'évier (12) et une unité d'appareil électroménager (14, 16), dans lequel un rail de montage (30) est monté sur la paroi de cuisine, le rail de montage (30) étant un élément allongé ayant une partie supérieure (32) et une partie inférieure (34), **caractérisé par** un robinet d'eau mobile (26) supporté de manière coulissante le long de la partie supérieure (32) du

- rail de montage,
une pluralité de supports de montage (52) qui sont reliés de manière coulissante au rail de montage (30) et comprennent des corps principaux en forme de collier (56) pour supporter la pluralité d'unités modulaires (12, 14, 16) dans lequel la pluralité d'unités incluent des extrémités contiguës qui se correspondent sensiblement et peuvent être reçues dans un des corps principaux en forme de collier des supports de montage pour être supportées le long du rail de montage.
2. Assemblage de cuisine modulaire selon la revendication 1, **caractérisé en ce que** la pluralité d'unités modulaires (12, 14, 16) inclut au moins une unité d'évier (12), une unité de réfrigération (14) et une unité de cuisinière (16). 5
 3. Assemblage de cuisine modulaire selon la revendication 1, **caractérisé en ce que** le rail de montage (30) loge une pluralité de conduits fonctionnels (42, 44) pour fournir du courant et de l'eau aux unités modulaires (12, 14, 16). 10
 4. Assemblage de cuisine modulaire selon la revendication 1, **caractérisé en ce que** le rail de montage (30') est formé d'un élément supérieur (32') et d'un élément inférieur séparé (34'). 15
 5. Assemblage de cuisine modulaire selon la revendication 4, **caractérisé en ce que** l'élément supérieur (32') loge une pluralité de conduits fonctionnels (42, 44) pour fournir du courant et de l'eau aux unités modulaires (12, 14, 16). 20
 6. Assemblage de cuisine modulaire selon la revendication 1, **caractérisé en ce qu'**un élément de hotte (24) s'étend depuis la partie supérieure (32) du rail de montage (30). 25
 7. Assemblage de cuisine modulaire selon la revendication 6, **caractérisé en ce que** l'élément de hotte (24) est formé par une paire d'élément de cadre s'étendant vers le haut depuis le rail de montage (30) pour supporter un couvercle de hotte (90). 30
 8. Assemblage de cuisine modulaire selon la revendication 7, **caractérisé en ce que** le courant électrique est fourni à un élément d'éclairage (92) monté dans le couvercle de hotte (90) par une des paires d'éléments de cadre et un commutateur (94) est fourni sur le rail de montage (30) pour contrôler l'alimentation en énergie de l'élément d'éclairage. 35
 9. Assemblage de cuisine modulaire selon la revendication 1, **caractérisé en ce que** le système de cuisine modulaire comprend une surface de travail supérieure formée par une combinaison d'unités mo- 40
- dulaires et la partie supérieure du rail de montage.
10. Assemblage de cuisine modulaire selon la revendication 9, **caractérisé en ce que** la pluralité d'unités modulaires (12, 14, 16) inclut au moins une unité d'évier (12) et une unité de réfrigération (14) et dans lequel l'unité de réfrigération inclut un tiroir (98) et une surface supérieure transparente (106). 45
 11. Assemblage de cuisine modulaire selon la revendication 10, **caractérisé en ce que** la pluralité d'unités modulaires (12, 14, 16) inclut aussi une unité de cuisinière (16) sur laquelle des récipients de cuisine peuvent être placés et le robinet d'eau mobile (26) peut être positionné de manière coulissante adjacent à l'unité de cuisinière pour fournir de l'eau à des tels récipients de cuisine. 50

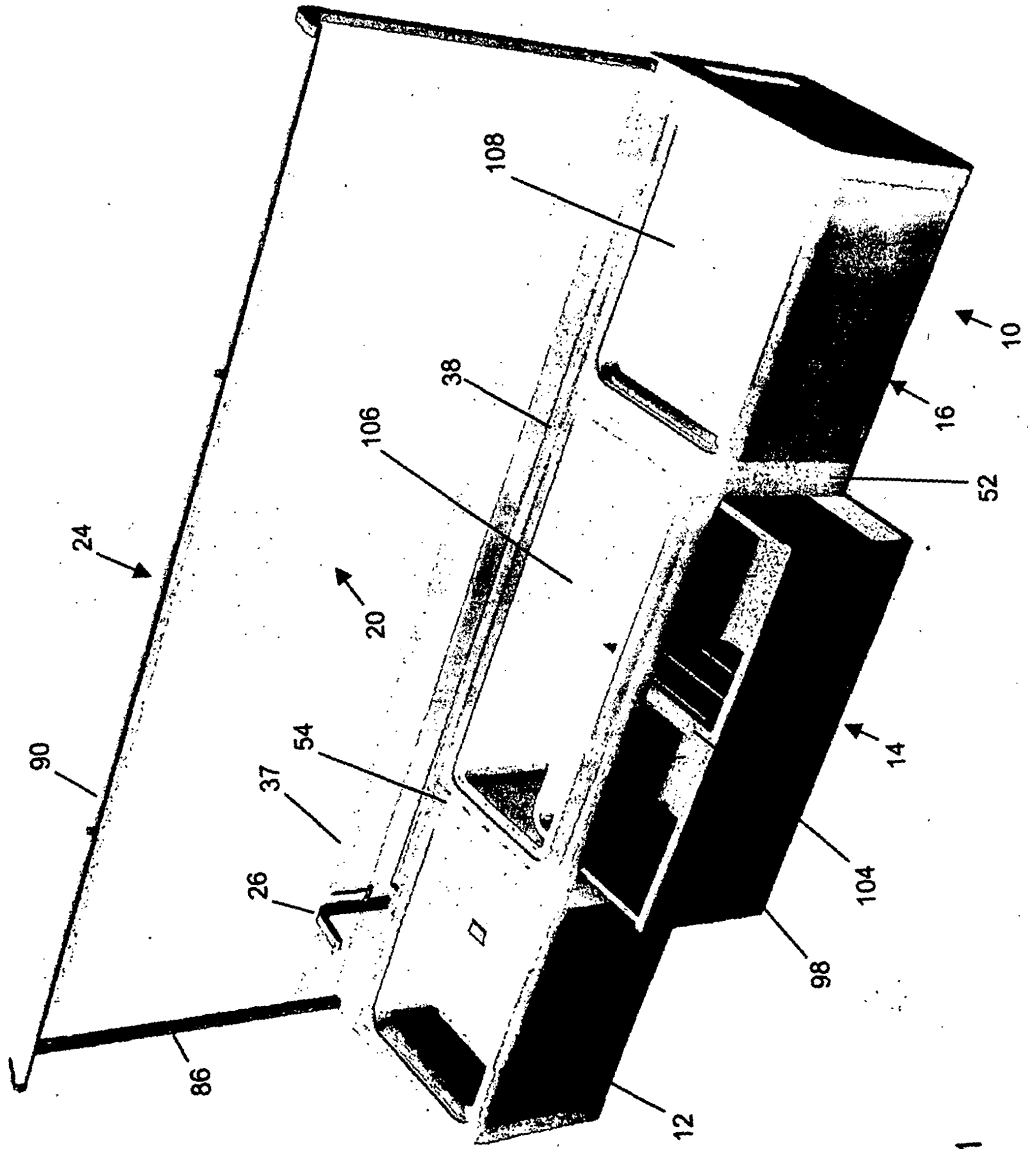

Fig.1

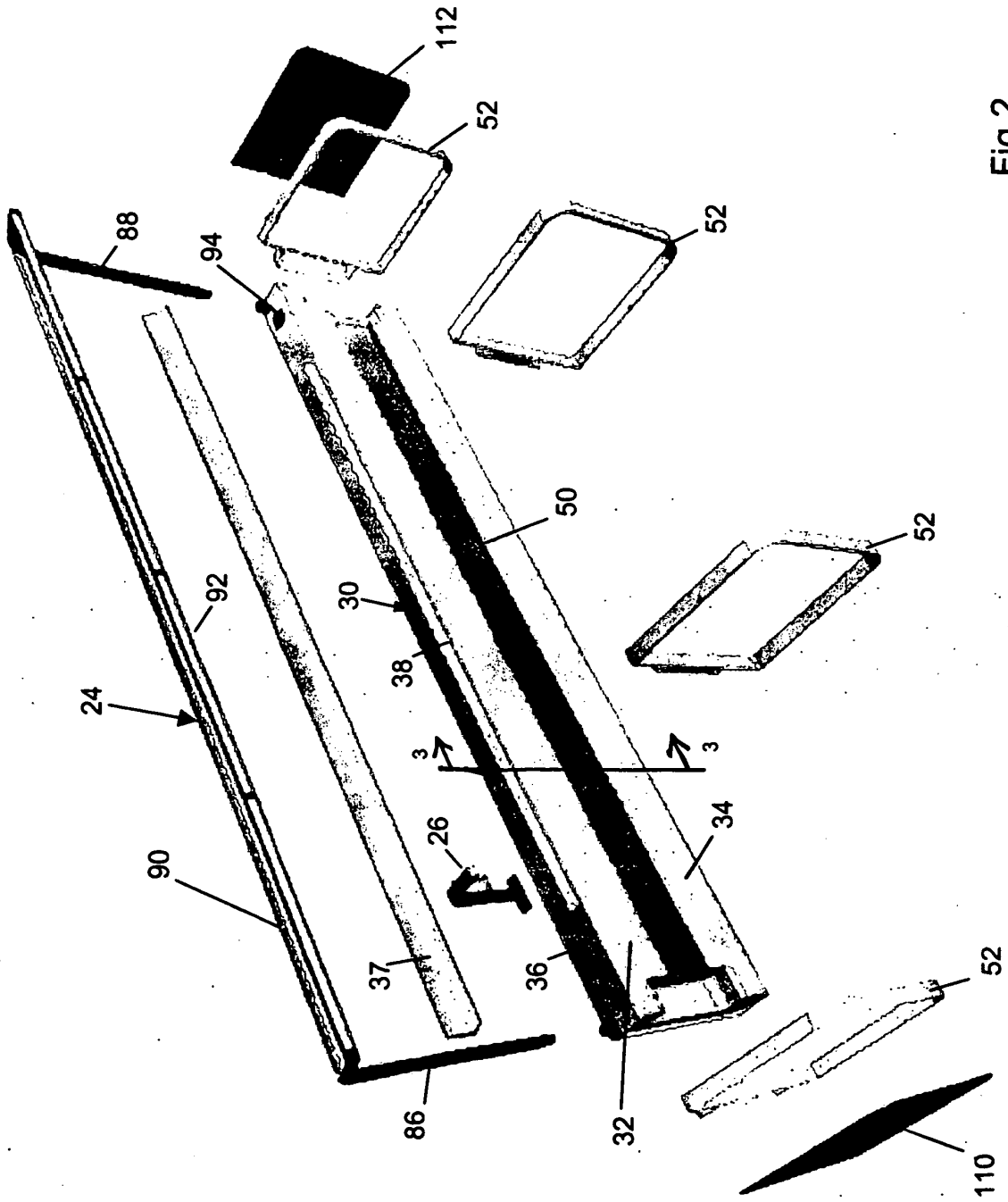

Fig.2

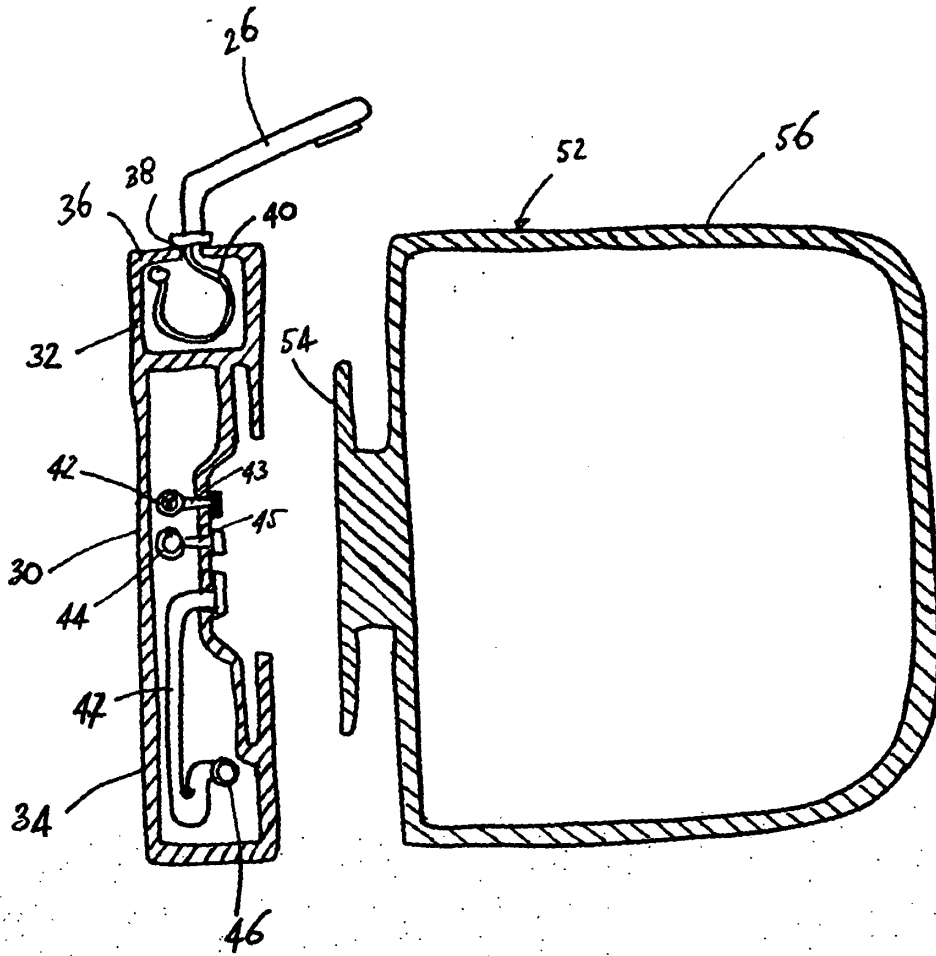

Fig. 3

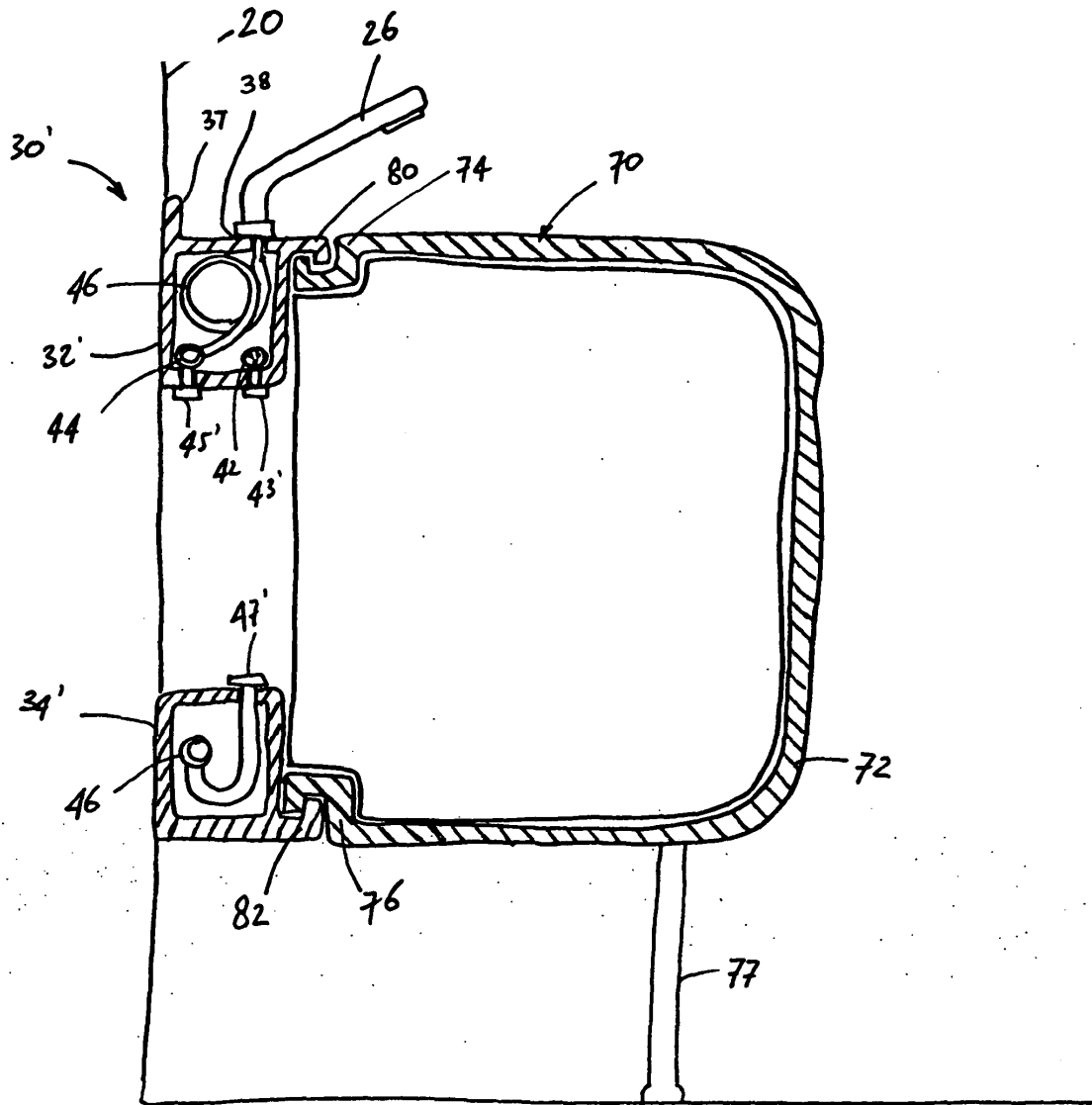

fig. 4

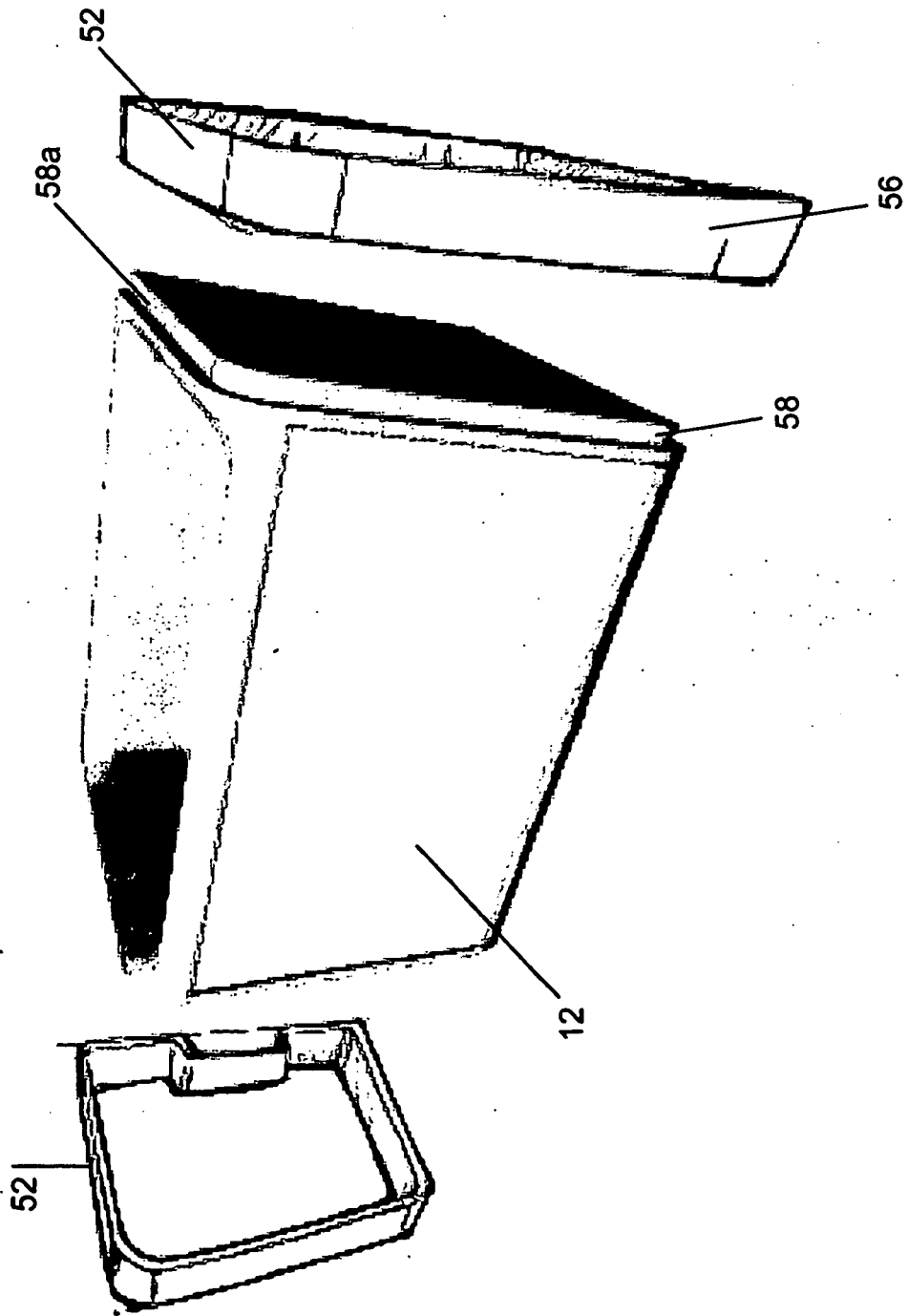

Fig.5

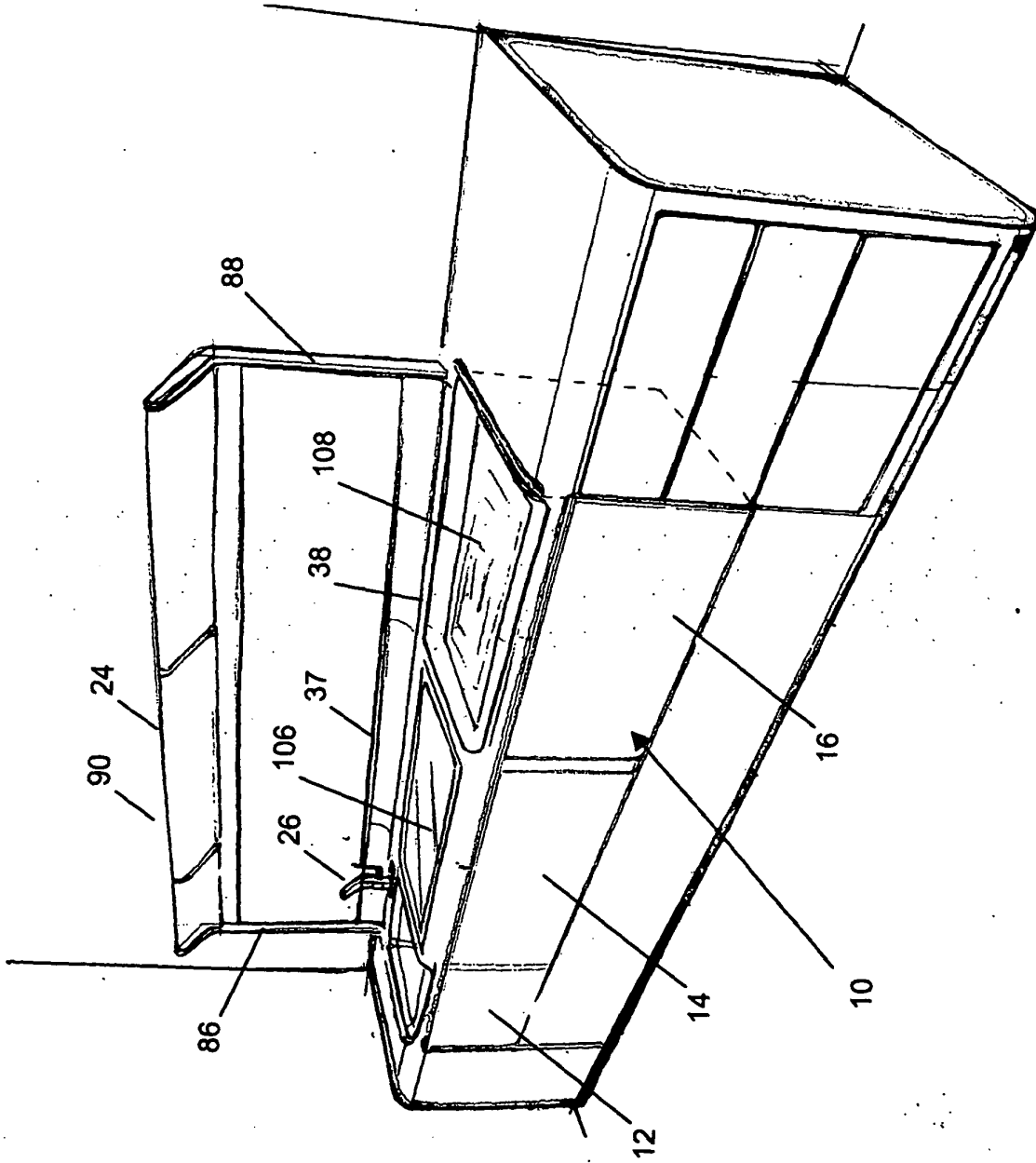

Fig.6

REFERENCES CITED IN THE DESCRIPTION

This list of references cited by the applicant is for the reader's convenience only. It does not form part of the European patent document. Even though great care has been taken in compiling the references, errors or omissions cannot be excluded and the EPO disclaims all liability in this regard.

Patent documents cited in the description

- US 20030227240 A1 [0004]
- US 313727 A [0004]
- US 5513908 A [0005]
- US 5392934 A [0006]