



(11) **EP 2 000 573 B1**

(12) **EUROPEAN PATENT SPECIFICATION**

(45) Date of publication and mention of the grant of the patent:
25.01.2012 Bulletin 2012/04

(51) Int Cl.:
D06B 5/12 (2006.01)

(21) Application number: **07252252.7**

(22) Date of filing: **05.06.2007**

(54) **Method and apparatus for flow control in a package dyeing machine**

Verfahren und Vorrichtung zur Durchflusssteuerung in einer Maschine zum Färben von Textilspulen

Procédé et appareil pour la commande du débit dans une machine de teinture des bobines textiles

(84) Designated Contracting States:
DE TR

(43) Date of publication of application:
10.12.2008 Bulletin 2008/50

(73) Proprietor: **Falmer Investments Limited**
Road Town, Tortola (VG)

(72) Inventor: **Tsui, Tak Ming William**
Causeway Bay
Hong Kong (HK)

(74) Representative: **McGowan, Cathrine**
D Young & Co LLP
120 Holborn
London EC1N 2DY (GB)

(56) References cited:
EP-A- 0 851 053 DE-A- 19 851 795

EP 2 000 573 B1

Note: Within nine months of the publication of the mention of the grant of the European patent in the European Patent Bulletin, any person may give notice to the European Patent Office of opposition to that patent, in accordance with the Implementing Regulations. Notice of opposition shall not be deemed to have been filed until the opposition fee has been paid. (Art. 99(1) European Patent Convention).

Description**BACKGROUND OF THE INVENTION**

[0001] The present invention relates to a method and apparatus for controlling the flow of treatment fluid in a package dyeing machine.

[0002] Textiles such as yarn, thread, ribbon and the like are commonly wound onto large conical spools or bobbins to form packages for handling by textile treatment machines. Textile treatment includes dyeing and also treating with substances other than dye, where the dye stuff or other treatment substance is diluted in water to give a treatment fluid or liquor. A quantity of packages are loaded onto hollow spindles inside the kier of a treatment machine, the kier is filled with the treatment fluid, and the fluid is then passed through the packages using a fluid circulation system. A pump drives fluid around the circulation system.

[0003] To achieve an even treatment effect such as uniform dyeing, two fluid flow paths are typically used. An inside-to-out flow path sends fluid up inside the hollow spindle, through perforations in the spindle wall and outwardly through the package, to the main volume of the kier. An opposite, outside-to-in flow path forces fluid from the main volume of the kier inwardly through the package, through the spindle wall and into the central hollow space in the spindle.

[0004] A typical treatment cycle will include periodic switching between these two flow directions. This is a widely-accepted technique to minimise unevenness in the treatment. The change in flow direction is achieved by a mechanical flow reversal device in the fluid circulation system together with a unidirectional pump. However, the structure of flow reversal devices is such that the resistance to flow for the two flow directions is different, because the distance of travel and the nature of the flow is not the same. A consequence of this is that the performance of the pump is also different for the two flow directions, giving different rates of flow. To balance this difference for the purpose of achieving an even treatment result, different cycle times for the two flow directions are commonly used. The time difference is typically obtained through experience.

[0005] This practice is open to improvement, since it is over-reliant on human experience and human error. Also, the time required to obtain the timing parameters can be extensive. Further disadvantages arise because large quantities of treatment fluid, possibly at high temperatures need to be circulated for longer than might otherwise be necessary, which wastes energy. Moreover, because the known method relies heavily on experience, new recipes for dyes and the like have to be extensively tested to find a reasonable balance between the inside-to-out and outside-to-in flow directions; this means that adaptability and repeatability cannot be guaranteed.

[0006] DE-A-19851795 (Thies GmbH & Co) discloses a mechanism for measuring differential pressure in a

pump and thereby calculating a fluid flow rate through the attached system.

SUMMARY OF THE INVENTION

[0007] Accordingly, a first aspect of the present invention is directed to a method of controlling fluid flow rate during operation of a textile package fluid treatment machine, comprising: measuring the differential pressure across a unidirectional pump in a fluid circulation system connected to a kier of the machine and comprising a reversal device which is switched during operation of the machine to reverse the direction of fluid flow through at least one package in the kier; calculating an actual fluid flow rate through the fluid circulation system from the measured differential pressure using a performance characteristic of the pump; monitoring the actual flow rate over time to determine the accumulated flow between each switching of the reversal device; and using the accumulated flow information to automatically control switching of the reversal device such that total flow between each switching of the reversal device is substantially equal.

[0008] The method therefore corrects the flow rate for changes that typically exist between the two flow directions. Equal flow in each direction is important for achieving a good treatment result, but changes in flow rate may arise after each switching of the reversal device. By monitoring the accumulated flow after each switching operation, the switching can be carried out at the appropriate times to ensure that the total flow is the same. The method allows the correct flow to be used without the need for any human estimation or experience, so that human error is removed from the treatment process, and better quality textiles can be produced.

[0009] In an alternative embodiment, the method may further comprise comparing the actual fluid flow rate with a desired fluid flow rate for the at least one package to determine any flow rate difference; and using the flow rate difference to automatically adjust operation of the pump such that the flow rate difference is reduced.

[0010] By this technique, the need for human estimation, and hence the risk of human error, is also removed from the provision of the correct flow rate, thereby further improving the textile quality. According to this embodiment, the method can be operated as a feedback arrangement to allow constant monitoring and adjustment of the flow rate throughout an entire treatment process so that any changes in flow rate arising from, for example, switching of the reversal device or fluctuations in pump performance can be compensated and corrected as they arise.

[0011] Any reduction in the flow rate difference is advantageous, but preferably the method is used to substantially match the actual flow rate to the desired flow rate. Therefore, operation of the pump may be adjusted such that the flow rate difference is substantially eliminated. Several adjustments may be required to achieve

this.

[0012] Any suitable type of pump may be used. Typically, however, the pump will be driven by a motor, in which case automatically adjusting operation of the pump may comprise automatically controlling operation of a motor that drives the pump.

[0013] The desired flow rate may be provided directly, if known. Alternatively, it may be determined for the particular treatment process to be performed from more readily available parameters. This simplifies things for the machine operator. For example, the method may further comprise calculating the desired flow rate from the size of the load in the kier and the performance index of the textile in the at least one package.

[0014] A second aspect of the present invention is directed to apparatus for controlling fluid flow rate during operation of a textile package fluid treatment machine, comprising: a differential pressure sensor connectable across a unidirectional pump in a fluid circulation system connected to a kier of the machine and comprising a reversal device switchable to reverse the direction of fluid flow through at least one package in the kier; a reversal device controller connectable to the reversal device and operable to control switching of the reversal device during operation of the machine; a flow rate calculator arranged to receive differential pressure data measured by the differential pressure sensor and operable to calculate an actual fluid flow rate through the fluid circulation system using a performance characteristic of the pump; and a levelness control unit arranged to receive the actual flow rate from the flow rate calculator and operable to monitor the actual flow rate over time to determine the accumulated flow between each switching of the reversal device, and to provide instructions to the reversal device controller to switch the reversal device such that total flow between each switching of the reversal device is substantially equal.

[0015] In a further embodiment, the apparatus may further comprise an input device for receiving operator input relating to a desired flow rate for the at least one package; a comparator operable to compare the actual flow rate and the desired flow rate to determine any flow rate difference; and a pump controller connectable to the pump, and arranged to receive flow rate difference data from the comparator and operable to adjust operation of the pump such that the flow rate difference is reduced.

[0016] Operation of the pump may be adjusted such that the flow rate difference is substantially eliminated.

[0017] The pump controller may be operable to adjust operation of the pump by controlling operation of a motor that drives the pump.

[0018] The input device may be configured to receive operator input of the size of the load in the kier and the performance index of the textile in the at least one package, with the apparatus further comprising a flow rate converter operable to calculate the desired flow rate from the operator input. This removes the need for the operator to know or calculate the desired flow rate, and allows the

more simpler step of entry of more directly available data.

[0019] A third aspect of the present invention is directed to a textile package fluid treatment machine provided with apparatus according to any embodiment of the second aspect. The machine may be a textile package dyeing machine, for example.

BRIEF DESCRIPTION OF THE DRAWINGS

[0020] For a better understanding of the invention and to show how the same may be carried into effect reference is now made by way of example to the accompanying drawings in which:

Figure 1 shows a schematic representation of a conventional textile package treatment machine having a fluid circulation system with a pump and a reversal device;

Figure 2 shows a schematic representation of a textile package treatment machine having a fluid circulation system with a pump and a reversal device and apparatus for controlling the fluid flow according to an embodiment of the invention; and

Figure 3 shows a graph of a performance characteristic of an example pump such as may be used in conjunction with embodiments of the present invention.

DETAILED DESCRIPTION

[0021] Figure 1 shows a simplified schematic diagram of a conventional package dyeing machine with a fluid circulation system. The machine 20 comprises a kier 22 for holding a plurality of textile packages during a fluid treatment process such as dyeing. For simplicity, only one package 26 is shown. The package 26 is supported on a vertical hollow spindle 24 extending up from the base of the kier 22. The base of the kier 22 also includes two fluid inlet/outlet ports. One port 28 connects with the hollow interior of the spindle 24. The other port 30 opens in the base of the kier 22 remote from the spindle to as to communicate with the main volume of the kier.

[0022] A fluid circulation system is connected to the ports 28, 30, and operates to circulate treatment fluid through the package 26. The system comprises a pipe network 34 and a pump 36 in the pipe network operable to drive fluid around the pipe network 34 and into the kier 22. The pump 36 is unidirectional and circulates fluid only in the direction indicated by the single-headed arrows.

[0023] For even treatment of the textile (such as a uniform dyeing result), it is preferred to circulate the fluid through the package in two opposing directions, from inside to out and from outside to in. Inside-to-out flow passes from the hollow interior of the spindle 24, through the spindle wall (which is perforated) and through the package to the main volume of the kier. Outside-to-in flow follows the reverse direction. The two flow directions are indicated by the double-ended arrows. To achieve the

two opposite flow directions from the unidirectional pump 36, a flow reversal device 32 is interposed between the pipe network 34 and the kier 22. The reversal device 32 has an inlet 38 for receiving fluid from the pipe network 34 and an outlet 40 for returning fluid to the pipe network 34, plus connections to the two ports 28, 30 in the base of the kier. A mechanical mechanism in the reversal device 32 can be switched between an inside-to-out flow position which connects the inlet 38 to the port 28 under the spindle 24 and connects the port 30 in the base of the kier 22 to the outlet 40, and an outside-to-in flow position which connects the inlet 38 to the port 30 in the base of the kier 22 and connects the port 28 under the spindle 24 to the outlet 40. A range of flow reversal devices is known.

[0024] A typical treatment process comprises several alternating periods of flow in each direction, with the aim of providing equal total flow for each period. As discussed in the introduction, the duration of the periods for the two flow directions must generally be unequal to compensate for differences in the resistance to flow for each flow direction, arising in part from the construction of the reversal device. The timings are determined by user experience, and are hence prone to error.

[0025] To address this, according to the present invention there is proposed a method of automatically controlling the flow, which can be performed using an apparatus such as is shown in Figure 2.

[0026] Figure 2 shows a package dyeing machine similar to the conventional machine 20 of Figure 1, comprising a kier 1 having a fluid circulation system comprising a pipe network 14, a reversal device 2 connected between the pipe network 14 and the kier 1, and a unidirectional pump 15. In this example, the pump 15 is driven by a motor 4.

[0027] The machine is provided with an apparatus according to an embodiment of the invention for automatically controlling the fluid flow through the packages in the kier such that substantially equal amounts of flow can be provided in each flow direction during a single treatment process.

[0028] A pump has a performance characteristic that relates the flow rate it produces to the pressure difference (pressure head) across the pump. Figure 3 shows an example of a pump performance characteristic, illustrated as a graph showing the relationship between the head and the flow rate. In this case, the relationship is substantially linear with a shallow decline, such that a small change in the pressure difference (the decrease from point A to point B, for example) gives a large change to the flow rate (the increase from point r to point s, for example). The present invention makes use of the relationship. The exact nature of the relationship is immaterial, so long as it is known or can be determined for the pump being used. Therefore, the invention is not limited to a pump with a performance characteristic as shown in Figure 3.

[0029] Returning to Figure 2, the apparatus includes

a differential pressure sensor 5. This is connected to the inlet 3 and the outlet 13 of the pump 15, so as to measure the pressure difference (differential pressure) across the pump 15 while the pump 15 is in operation to circulate fluid through packages in the kier 1. The differential pressure will vary according to the rate at which the motor 4 is driving the pump 15, and the direction of flow as set by the reversal device 2.

[0030] The measured differential pressure is supplied from the sensor 5 to a flow rate calculator 6. The flow rate calculator 6 is provided with information regarding the performance characteristic of the pump 15, and is operable to calculate the flow rate from the differential pressure, using the performance characteristic. The calculator may be implemented by hardware or software. The calculation may be carried out using a look-up table that lists values of flow rate for the corresponding values of differential pressure, or using the equation that describes the curve of the performance characteristic, for example.

[0031] The apparatus further comprises a flow rate converter 7 connected to an input device 10 which allows an operator of the machine to enter a value for the flow rate at which it is desired that a treatment process should be carried out. This value is supplied to the flow rate converter 7. Alternatively, the input device 10 can allow user input of data from which the desired flow rate can be determined. This may be an input of the size or capacity 11 of the textile load that is to be contained in the kier 1, and an input of the performance index of the textile (a parameter describing the ease of treating that textile with the particular treatment fluid to be used). The input device 10 may have a display screen, and a keypad, keyboard or other entry device via which the data can be entered. The display screen may show messages prompting the user to enter the required data. The data is entered before operation of the machine. The flow rate converter 7 is then operable to calculate the desired flow rate from the data entered by the user. As with the flow rate calculator 6, this may be performed using equations or a look-up table, and by software or hardware.

[0032] Once the desired flow rate is obtained, it is supplied by the flow rate converter 7 to a comparator 16. Then, during operation of the machine, the comparator 16 also receives from the flow rate calculator 6 the calculated actual flow rate. The comparator 16 compares the two flow rates to determine any difference between them. A difference indicates that the pump is not circulating the treatment fluid at the appropriate flow rate for the process. To correct this, a motor controller 12 is arranged to receive flow rate difference data from the comparator 16, and, using the data, to generate and send control signals to the motor 4 to turn the motor up or down as appropriate to change the rate at which the pump 15 operates. Alternatively, the control signals may be generated by the comparator 16 and sent to the motor controller 12 which then operates to adjust the motor 4.

[0033] The aim of the adjustment to the motor 4 is to

reduce the flow rate difference so that the actual flow rate substantially matches the desired flow rate. This may require several cycles of measurement and adjustment. Hence, the control may be carried out continuously during operation of the machine. The magnitude of the flow rate difference determines by how much the motor is adjusted, and the sign of the flow rate difference determines whether the motor operation is increased or decreased. Further measurement of the differential pressure, calculation of the flow rate and comparison with the desired flow rate will determine if further adjustment to the motor is necessary, and so on. Overall, therefore, the apparatus can provide a feedback loop for controlling the pump throughout operation of the machine.

[0034] In particular, adjustment will likely be required when the reversal device 2 is switched between positions for the two flow directions. In this way, changing the rate at which the motor 4 drives the pump 15 compensates for the inherent differences in flow rate for the two opposite flow directions. The flow rates for both directions can therefore be matched to the desired flow rate. Once this is achieved, the reversal device can be operated such that the two flow directions are used for substantially equal time periods, to produce substantially equal total amounts of flow for each direction during each period and over the whole treatment process. This gives an even and uniform treatment of the textiles.

[0035] The machine might therefore be operated using periodic switching of the reversal device at pre-set intervals to match the flow times for each direction. However, while such operation is attractively simple, it may be found that the oscillations which often occur in a feedback system and the time taken to reach a steady state after each switching of the reversal device are significant so that mere operation of the machine with equal times for each flow direction does not produce a good enough balance between the total flow in each direction.

[0036] Therefore, a further embodiment proposes a dynamic control of the reversal device 2 to address this issue, and achieve equal flow in each flow direction.

[0037] Referring again to Figure 2, the apparatus accordingly may further comprise a reversal device controller 9 connected to the reversal device 2 and operable to switch the reversal device 2 between its two positions. Also, a levelness control unit 8 is connected between the flow rate calculator 6 and the reversal device controller 9. The levelness control unit 8 continuously receives the real-time calculated actual flow rate from the flow rate calculator 6. It also generates control signals for transmission to the reversal device controller 9 to tell the reversal controller when to switch the reversal device. Therefore, the levelness control unit 8 knows which flow direction is being used.

[0038] The levelness control unit 8 operates by monitoring the actual flow rate over time for the two flow directions to determine the accumulated flow in each time period for each flow direction as the process proceeds. Based on this information, the levelness control unit 8

determines when the reversal device should be switched so as to achieve the same amount of flow for each time period of the reversal device, and hence a balance between the total inside-to-out flow and the total outside-to-in flow over the entire treatment process. The levelness control unit 8 can be implemented by hardware or software, and may perform its function by use of an algorithm, for example.

[0039] Overall, therefore, embodiments of the invention provide automated dynamic control of the pump and the reversal device over the course of a treatment process carried out by the machine, to provide equal total flows for the two opposite fluid flow directions. After data relating to the desired flow rate (either the rate itself or data from which it can be calculated by the apparatus) has been provided to the apparatus, the treatment process with automated control can be initiated and completed without further operator input. Furthermore, it is possible to implement only the control of the reversal device, without including control of the pump.

[0040] Figure 2 shows the apparatus embodied as separate modules. Each module may be implemented using hardware, software or firmware as desired or as appropriate. The functions of more than one module may be combined within a single unit. For example, with the exception of suitable pressure transducers to provide the pressure measurements required to determine the differential pressure, the whole apparatus may be implemented as software running on a single processor that receives the pressure measurements from the pump and the desired flow rate data input by the operator, and outputs control signals to the motor and the reversal device.

Claims

1. A method of controlling fluid flow rate during operation of a textile package fluid treatment machine, comprising:

measuring the differential pressure across a unidirectional pump (15) in a fluid circulation system connected to a kier (1) of the machine and comprising a reversal device (2) which is switched during operation of the machine to reverse the direction of fluid flow through at least one package in the kier;

calculating an actual fluid flow rate through the fluid circulation system from the measured differential pressure using a performance characteristic of the pump,

and **characterised by:**

monitoring the actual flow rate over time to determine the accumulated flow between each switching of the reversal device; and using the accumulated flow information to automatically control switching of the re-

- versal device such that total flow between each switching of the reversal device is substantially equal.
2. A method according to claim 1, further comprising:
- 5 comparing the actual fluid flow rate with a desired fluid flow rate for the at least one package to determine any flow rate difference; and using the flow rate difference to automatically adjust operation of the pump such that the flow rate difference is reduced. 10
3. A method according to claim 2, in which operation of the pump is adjusted such that the flow rate difference is substantially eliminated. 15
4. A method according to claim 2 or claim 3, in which automatically adjusting operation of the pump comprises automatically controlling operation of a motor (4) that drives the pump. 20
5. A method according to any one of claims 2 to 4, further comprising calculating the desired flow rate from the size of the load in the kier and the performance index of the textile in the at least one package. 25
6. Apparatus for controlling fluid flow rate during operation of a textile package fluid treatment machine, comprising:
- 30 a differential pressure sensor (5) connectable across a unidirectional pump (15) in a fluid circulation system connected to a kier (2) of the machine and comprising a reversal device (2) switchable to reverse the direction of fluid flow through at least one package in the kier; a flow rate calculator (6) arranged to receive differential pressure data measured by the differential pressure sensor and operable to calculate an actual fluid flow rate through the fluid circulation system using a performance characteristic of the pump, and **characterised by:**
- 35 a reversal device controller (9) connectable to the reversal device and operable to control switching of the reversal device during operation of the machine; and a levelness control unit (8) arranged to receive the actual flow rate from the flow rate calculator and operable to monitor the actual flow rate over time to determine the accumulated flow between each switching of the reversal device, and to provide instructions for the reversal device controller to switch the reversal device such that total flow between each switching of the reversal
- 40
- 45
- 50
- 55

device is substantially equal.

7. Apparatus according to claim 6, and further comprising an input device (10) for receiving operator input relating to a desired flow rate for the at least one package; a comparator (16) operable to compare the actual flow rate and the desired flow rate to determine any flow rate difference; and a pump controller (12) connectable to the pump, and arranged to receive flow rate difference data from the comparator and operable to adjust operation of the pump such that the flow rate difference is reduced.
8. Apparatus according to claim 7, in which operation of the pump is adjusted such that the flow rate difference is substantially eliminated.
9. Apparatus according to claim 7 or claim 8, in which the pump controller is operable to adjust operation of the pump by controlling operation of a motor (4) that drives the pump.
10. Apparatus according to any one of claims 7 to 9, in which the input device is configured to receive operator input of the size of the load in the kier and the performance index of the textile in the at least one package, and the apparatus further comprising a flow rate converter (7) operable to calculate the desired flow rate from the operator input.
11. A textile package fluid treatment machine provided with apparatus according to any one of claims 6 to 10.
12. A textile package fluid treatment machine according to claim 11, in which the machine is a textile package dyeing machine.

Patentansprüche

1. Verfahren zum Steuern der Fluidflussrate während des Betriebes einer Maschine zur Fluidbehandlung eines textilen Packstoffes, dass aufweist:

Messen des Differenzdruckes über einer unidirektionalen Pumpe (15) in einem Fluidzirkulationssystem, das mit einem Beuchkessel (1) der Maschine verbunden ist und eine Umkehrvorrichtung (2) aufweist, die während des Betriebes der Maschine geschaltet wird, um die Richtung des Fluidflusses durch zumindest einen Packstoff in dem Beuchkessel umzukehren, Berechnen einer tatsächlichen Fluidflussrate durch das Fluidzirkulationssystem aus dem gemessenen Differenzdruck unter Verwendung einer Leistungscharakteristik der Pumpe, und ge-

kennzeichnet durch:

- Überwachen der gegenwärtigen Flussrate über der Zeit, um den gesammelten Fluss zwischen jedem Schalten der Umkehrvorrichtung zu bestimmen, und
5
Verwenden der gesammelten Flussinformation, um automatisch das Schalten der Umkehrvorrichtung zu steuern, so dass der Gesamtfluss zwischen jedem Schalten der Umkehrvorrichtung im Wesentlichen gleich ist.
10
2. Verfahren nach Anspruch 1, das weiterhin aufweist:
15
Vergleichen der gegenwärtigen Fluidflussrate mit einer gewünschten Fluidflussrate für den zumindest einen Packstoff, um jegliche Flussratendifferenz zu bestimmen, und
Verwenden der Flussratendifferenz um automatisch den Betrieb der Pumpe derart einzustellen, dass die Flussratendifferenz reduziert wird.
20
3. Verfahren nach Anspruch 2, bei dem die Operation der Pumpe derart eingestellt wird, dass die Flussratendifferenz im Wesentlichen eliminiert wird.
25
4. Verfahren nach Anspruch 2 oder Anspruch 3, bei dem der automatische Einstellbetrieb der Pumpe das automatische Steuern des Betriebes eines Motors (4) aufweist, der die Pumpe antreibt.
30
5. Verfahren nach einem der Ansprüche 2 bis 4 das weiterhin aufweist das Berechnen der gewünschten Flussrate aus der Größe der Ladung in dem Beuchkessel und dem Gütegrad der Textilien in dem zumindest einen Packstoff.
35
6. Vorrichtung zum Steuern der Fluidflussrate während des Betriebes einer Maschine zur Fluidbearbeitung eines textilen Packstoffes, die aufweist:
40
einen Differenzdrucksensor (5), der über einer unidirektionalen Pumpe (15) in einem Fluidzirkulationssystem, das an einem Beuchkessel (2) der Maschine angeschlossen ist, verbindbar ist und eine Umkehrvorrichtung (2) aufweist, die schaltbar ist, um die Richtung des Fluidflusses durch zumindest einen Packstoff in dem Beuchkessel umzukehren,
45
einen Flussratenberechner (6), der angeordnet ist, um die Differenzdruckdaten, die durch den Differenzdrucksensor gemessen wurden, zu empfangen und betreibbar ist, um eine gegenwärtige Fluidflussrate durch das Fluidzirkulationssystem unter Verwendung einer Leistungscharakteristik der Pumpe zu berechnen,
50
und **gekennzeichnet durch:**
55
- einen Umkehrvorrichtungscontroller (9), der mit der Umkehrvorrichtung verbindbar ist und betreibbar ist, um das Schalten der Umkehrvorrichtung während des Betriebes der Maschine zu steuern, und
eine Gleichmäßigkeitssteuereinheit (8), die angeordnet ist, um die gegenwärtige Flussrate von dem Flussratenberechner zu empfangen und betreibbar ist, um die gegenwärtige Flussrate über der Zeit zu überwachen, um den gesammelten Fluss zwischen jedem Schalten der Umkehrvorrichtung zu bestimmen, und um Befehle bereitzustellen für den Umkehrvorrichtungscontroller, um die Umkehrvorrichtung derart zu schalten, dass der Gesamtfluss zwischen jedem Schalten der Umkehrvorrichtung im Wesentlichen gleich ist.
7. Vorrichtung nach Anspruch 6, die weiterhin eine Eingabevorrichtung (10) für das Empfangen einer Operatoreingabe betreffend eine gewünschte Rate für den zumindest einen Packstoff,
einen Vergleicher (16), der betreibbar ist, um die gegenwärtige Flussrate und die gewünschte Flussrate zu vergleichen, um jegliche Flussratendifferenz zu bestimmen, und
einen Pumpcontroller (12) aufweist, der mit der Pumpe verbindbar ist und angeordnet ist, um die Flussratendifferenzdaten von dem Vergleicher zu empfangen und betreibbar ist, um den Betrieb der Pumpe derart einzustellen, so dass die Flussratendifferenz reduziert wird.
8. Vorrichtung nach Anspruch 7, bei der der Betrieb der Pumpe derart eingestellt wird, dass die Flussratendifferenz im Wesentlichen eliminiert wird.
9. Vorrichtung nach Anspruch 7 oder Anspruch 8, bei der der Pumpencontroller betreibbar ist, um dem Betrieb der Pumpe einzustellen durch das Steuern des Betriebes eines Motors (4), der die Pumpe antreibt.
10. Vorrichtung nach einem der Ansprüche 7 bis 9, bei der die Eingabevorrichtung konfiguriert ist, um eine Operatoreingabe zu empfangen der Größe der Beladung in dem Beuchkessel und dem Güteindex der Textilien in dem zumindest einen Packstoff, und die Vorrichtung weiterhin aufweist einen Flussratenkonverter (7), der betreibbar ist, um die gewünschte Flussrate aus der Operatoreingabe zu berechnen.
11. Maschine zur Fluidbehandlung eines textilen Packstoffes, die mit einer Vorrichtung nach einem der Ansprüche 6 bis 10 ausgestattet ist.
12. Maschine zur Fluidbearbeitung eines textilen Packstoffes nach Anspruch 11, bei der die Maschine eine

textile Packstofffärbemaschine ist.

Revendications

1. Procédé de commande du débit de fluide pendant le fonctionnement d'une machine de traitement à fluide de bobine de textile, comprenant :

une mesure de la pression différentielle dans une pompe unidirectionnelle (15) dans un système de circulation de fluide raccordé à un autoclave (1) de la machine et comprenant un dispositif d'inversion (2) qui est commuté pendant le fonctionnement de la machine afin d'inverser la direction de l'écoulement de fluide à travers au moins une bobine dans l'autoclave ;
un calcul d'un débit réel de fluide à travers le système de circulation de fluide à partir de la pression différentielle mesurée en utilisant une caractéristique de fonctionnement de la pompe, et **caractérisé par** :

un contrôle du débit réel en fonction du temps pour déterminer l'écoulement cumulé entre chaque commutation du dispositif d'inversion ; et
une utilisation des informations d'écoulement cumulé pour commander automatiquement la commutation du dispositif d'inversion de façon que l'écoulement total entre chaque commutation du dispositif d'inversion soit sensiblement égal.

2. Procédé selon la revendication 1, comprenant en outre:

une comparaison entre le débit réel de fluide et un débit désiré pour ladite au moins une bobine afin de déterminer une différence de débit ; et
une utilisation de la différence de débit pour régler automatiquement le fonctionnement de la pompe de sorte que la différence de débit soit réduite.

3. Procédé selon la revendication 2, dans lequel le fonctionnement de la pompe est réglé de sorte que la différence de débit soit sensiblement supprimée.

4. Procédé selon la revendication 2 ou la revendication 3, dans lequel le réglage automatique du fonctionnement de la pompe comprend une commande automatique du fonctionnement d'un moteur (4) qui entraîne la pompe.

5. Procédé selon l'une quelconque des revendications 2 à 4, comprenant en outre un calcul du débit désiré à partir de la taille de la charge dans l'autoclave et

de l'indice de rendement du textile dans ladite au moins une bobine.

6. Appareil pour commander un débit de fluide pendant le fonctionnement d'une machine de traitement à fluide de bobine de textile, comprenant :

un capteur de pression différentielle (5) pouvant être raccordé à une pompe unidirectionnelle (15) dans un système de circulation de fluide raccordé à un autoclave (1) de la machine et comprenant un dispositif d'inversion (2) pouvant être commuté afin d'inverser la direction de l'écoulement de fluide à travers au moins une bobine dans l'autoclave ;
un calculateur de débit (6) conçu pour recevoir des données de pression différentielle mesurées par le capteur de pression différentielle et pouvant être commandé pour calculer un débit réel de fluide à travers le système de circulation de fluide en utilisant une caractéristique de fonctionnement de la pompe, et **caractérisé par** :

un dispositif de commande de dispositif d'inversion (9) pouvant être raccordé au dispositif d'inversion et pouvant être commandé pour commuter le dispositif d'inversion pendant le fonctionnement de la machine ; et
une unité de commande de régulation (8) conçue pour recevoir le débit réel du calculateur de débit et pouvant être commandée pour surveiller pour le débit réel en fonction du temps pour déterminer l'écoulement cumulé entre chaque commutation du dispositif d'inversion, et pour fournir des instructions au dispositif de commande de dispositif d'inversion pour commuter le dispositif d'inversion de sorte que l'écoulement total entre chaque commutation du dispositif d'inversion soit sensiblement égal.

7. Appareil selon la revendication 6, et comprenant en outre un dispositif d'entrée (10) destiné à recevoir une entrée de l'opérateur relative à un débit désiré pour ladite au moins une bobine ;
un comparateur (16) pouvant être commandé pour comparer le débit réel et le débit désiré pour déterminer une différence de débit ; et

un dispositif de commande de pompe (12) pouvant être raccordé à la pompe, et conçu pour recevoir des données de différence de débit du comparateur et pouvant être commandé pour régler le fonctionnement de la pompe de sorte que toute différence de débit soit réduite.

8. Appareil selon la revendication 7, dans lequel le

fonctionnement de la pompe est réglé de sorte que la différence de débit soit sensiblement supprimée.

9. Appareil selon la revendication 7 ou la revendication 8, dans lequel le dispositif de commande de pompe peut être commandé pour régler le fonctionnement de la pompe en commandant le fonctionnement d'un moteur (4) qui entraîne la pompe. 5
10. Appareil selon l'une quelconque des revendications 7 à 9, dans lequel le dispositif d'entrée est configuré pour recevoir une entrée de l'opérateur correspondant à la taille de la charge dans l'autoclave et à l'indice de rendement du textile dans ladite au moins une bobine, et l'appareil comprenant en outre un convertisseur de débit (7) peut être commandé pour calculer le débit désiré à partir de l'entrée de l'opérateur. 10
15
11. Machine de traitement à fluide de bobine de textile munie d'un appareil selon l'une quelconque des revendications 6 à 10. 20
12. Machine de traitement à fluide de bobine de textile selon la revendication 11, dans laquelle la machine est une machine de teinture sur bobine de textile. 25

30

35

40

45

50

55

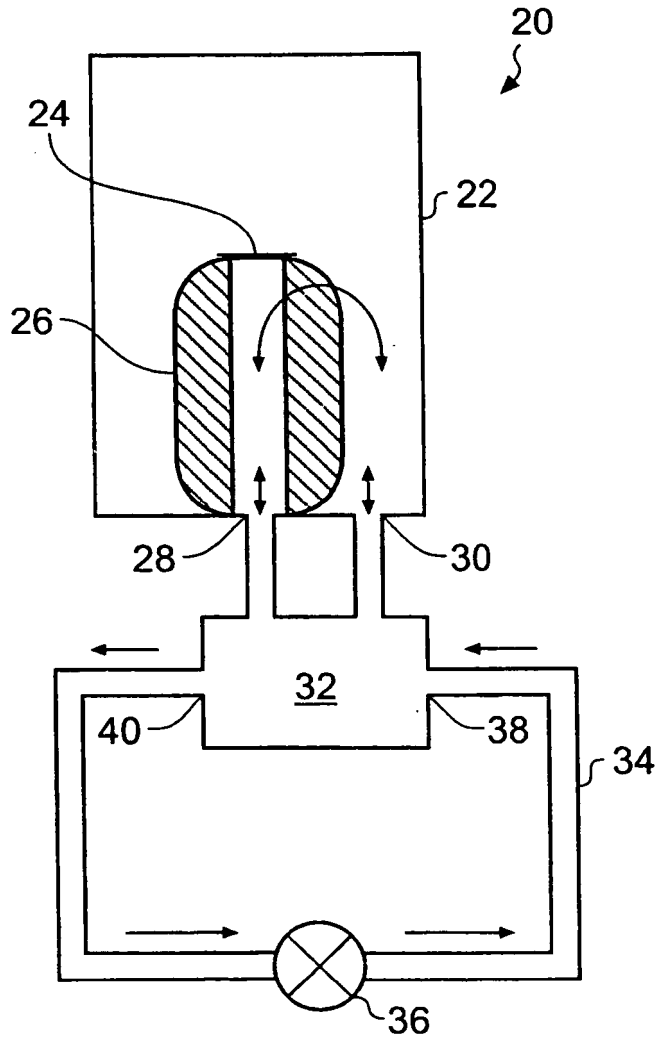

Fig. 1 (Prior Art)

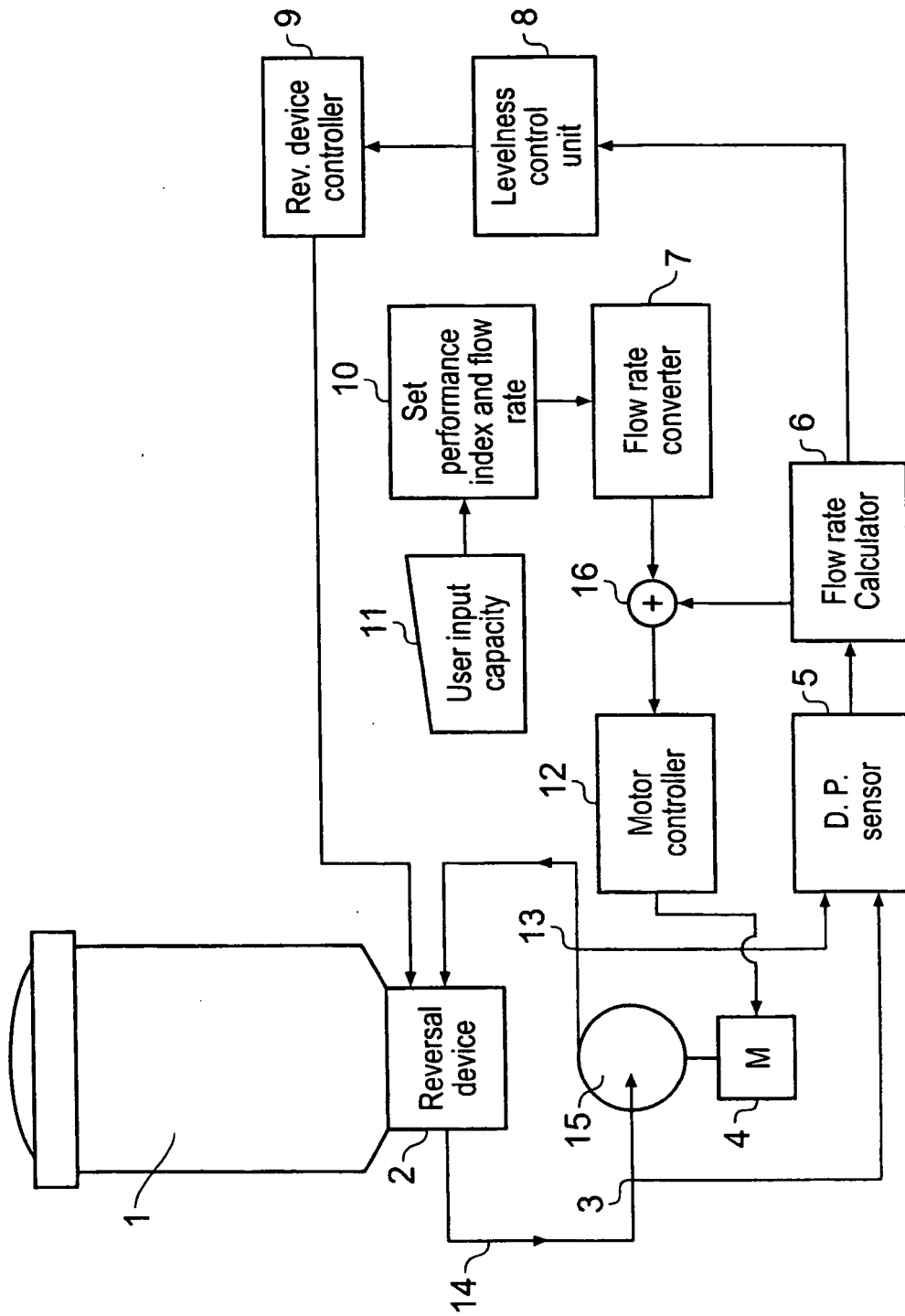

Fig. 2

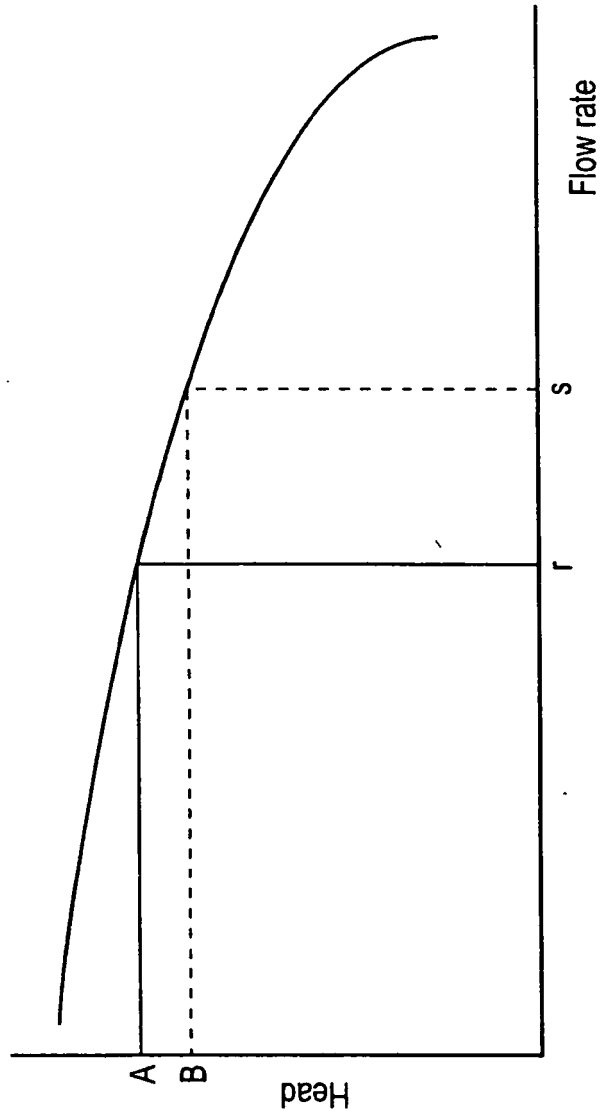

Fig. 3

REFERENCES CITED IN THE DESCRIPTION

This list of references cited by the applicant is for the reader's convenience only. It does not form part of the European patent document. Even though great care has been taken in compiling the references, errors or omissions cannot be excluded and the EPO disclaims all liability in this regard.

Patent documents cited in the description

- DE 19851795 A [0006]