

S. W. FISH.
SAFE.

APPLICATION FILED APR. 24, 1909.

997,791.

Patented July 11, 1911.

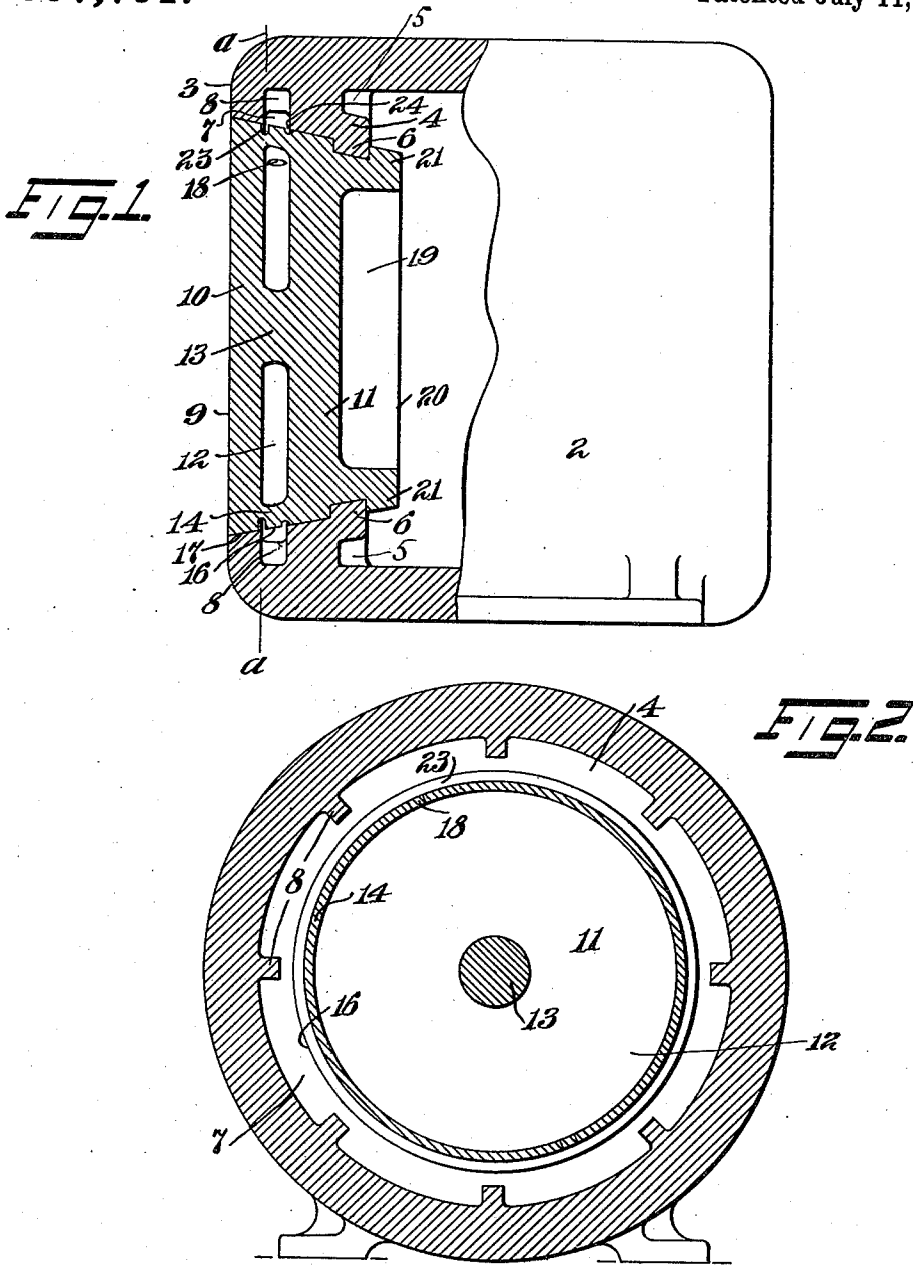

Witnesses:

C. F. Fuss.
H. D. Penney.

Inventor:

Samuel W. Fish,
By his Attorney,
F. H. Richards.

UNITED STATES PATENT OFFICE.

SAMUEL W. FISH, OF PLAINFIELD, NEW JERSEY, ASSIGNOR TO TAYLOR IRON & STEEL COMPANY, OF HIGH BRIDGE, NEW JERSEY, A CORPORATION OF NEW JERSEY.

SAFE.

997,791.

Specification of Letters Patent. Patented July 11, 1911.

Application filed April 24, 1909. Serial No. 491,986.

To all whom it may concern:

Be it known that I, SAMUEL W. FISH, a citizen of the United States, residing in Plainfield, in the county of Union and State of New Jersey, have invented certain new and useful Improvements in Safes, of which the following is a specification.

This invention relates to safes or vaults, the object of the invention being to provide, in connection with a chambered, or what may be construed as a compound, door for safes, an auxiliary locking or securing means effective under certain contingencies to prevent the door from being separated from the body, and is in part an improvement upon the construction shown and described in my contemporaneously pending application, filed April 24, 1909, Serial No. 491,985.

In the drawings accompanying and forming part of this specification, Figure 1 is a side, partly sectional, view of this improved safe; and Fig. 2 is a cross sectional view taken in line *a-a*, Fig. 1.

Similar characters of reference indicate corresponding parts in the figures of the drawings.

The safe body 2 in the present embodiment may be made up of any desired size or shape, and is provided with a relatively long jamb 3, usually of tapered circular formation, this jamb being formed partly by an inwardly or rearwardly extending flange 4 having a recess 5 between it and the adjacent side walls of the body, whereby the uniformity of the metal, when the body is made of unmachineable metal or manganese steel, and heat treated, is maintained. This flange is provided, in the embodiment shown, with a series of door locking lugs or locking surfaces 6, shown herein at the inner end of the flange. Between these locking surfaces or lugs and the outer terminus of the jamb a chamber 7, shown as of annular formation, is located, this chamber opening into the jamb. The adjacent boundary walls of this chamber may be connected to each other and to the body proper by a series of ribs 8, if preferred.

The door 9, which is shown as a circular and a rotary one, comprises a front section 10 and a rear section 11 rigidly, as for instance integrally, united so as to form a chamber 12 between such sections. In practice these door sections may be connected

centrally thereof, if preferred, by a disk or block of metal 13. The two sections are also rigidly, as for instance integrally, joined together by an annular web of metal 14 located at the outer terminus of the chamber 12 and the outer surface 16 of which web of metal constitutes a part of the door edge or periphery 17. By this construction I am able to provide a chambered door the chamber of which is closed adjacent to the door edge by a web of metal integral with the door, and in order to cast this door one or more openings 18 are formed in the web for the removal of the core, these openings being subsequently filled up by some suitable metal. The rear section 11 of the door, which is shown as somewhat thicker than the front section, is chambered as at 19 to form a rearwardly extending flange 20 having lugs 21 adapted to cooperate with the locking lugs of the body when the door is rotated into position.

Any suitable hinge may be used for supporting the door on the body, and any suitable locking means may be used for preventing rotary movement of the door. As these features, however, do not constitute a part of my present invention they have not been shown in the drawings.

When the door is seated in its jamb, the chamber closing web 14 is in juxtaposition to the annular chamber located in the jamb. In practice this web is weakened by the provision of slots or recesses 23, 24, two thereof being shown, and in the present embodiment one of these slots or recesses, as 23, which are of annular formation, is somewhat deeper than the other. By the provision of these slots the separation of the web from the door sections is facilitated, and by reason of one slot being somewhat deeper than the other the separation is most likely to take place at the weakest point.

As burglarious attacks on safes made of unmachineable metal, especially when made of an integral body and an integral door, are usually attempted at the door joint, it will be observed that should a burglar be successful in getting liquid nitro-glycerin into the joint of the door it would tend to run down and be trapped in the chamber of the jamb at the underside of the door, and if he should be successful, notwithstanding this, in exploding it the result would be

that the explosive force exerted would naturally take the path of least resistance and consequently would so act, it is apprehended, upon this annular web of metal as to sever a part or parts thereof at its weakest point, and this would, of course, be the points of connection of the web with the sections of the door, and thus, if the explosion for instance occurred at the lower edge of the door, a part of this web of metal would be blown inwardly into the chamber, while other parts of the web of metal, owing to the explosive action of the gases penetrating within the door chamber, would be blown outwardly into the chamber of the jamb, and so cooperate with the outer or front wall of the chamber which extends transversely to the axis of the door that the door is held securely in the doorway. In other words, with parts of such web located in the chamber of the jamb and other parts remaining in the chamber of the door the door would be locked more rigidly in its seat. In other words an explosion acting on the weakened web at the underside of the door, would of course force this web inward into the chamber between the door sections. At the same time the continued action of the explosive gases penetrating the door chamber, would act on the inner or underside, or other portion of the web and tend to force a part thereof into the chamber in the jamb. That is to say, when the explosive charge was exploded at a certain point, as the underside of the jamb, this portion of the web, would of course, be blown into the portion of the door between the door sections, but the explosive gases penetrating this chamber would also force outward other portions of the web into the chamber of the jamb. In short some portions of the web would go in one direction, while others in another and so lock the door to the body. Moreover, since the tendency of the web would be to separate at its weakest point, which is that part having the deeper slot or recess, it follows that a part of the web, while probably still remaining connected with the inner section of the door, would be forced outwardly into the chamber of the jamb. This thus provides an auxiliary locking means for holding the door in the seat of the body, thus materially interfering with the separation of the door from the jamb, in consequence of which a considerable portion of the time which a burglar would have at his disposal would be used up without any appreciable result so far as obtaining entrance to the safe is concerned. Should, however, a further and larger charge of nitro-glycerin be inserted into the door joint and exploded within the chamber of the door the only result would be to separate the outer thinner section 10 of such door from the main or thicker section 11 thereof, thus

leaving the latter still locked and securely held in the body by its locking lugs. Should a burglar be successful in accomplishing this he would still find it necessary to remove those sections of the door web which, under the explosive charge, had been forced into the receiving chamber of the jamb, and if the door were made of unmachineable metal, such for instance as manganese steel and heat treated, he would find it difficult to manipulate even comparatively small parts of this web or auxiliary locking means so as to remove them from the chamber of the jamb, and thus considerable further time would be taken up before the burglar would be able to attack the main part of the door itself. It will also be observed that the ribs located in the chamber of the jamb not only act to secure the adjacent walls of the chamber together, but are so positioned that the entrance of portions of the web wholly within the jamb chamber would be prevented, so that the parts of such web would project both into the chamber of the door at the edge thereof and into the chamber of the jamb. Thus there is provided a door chamber closing means comprising a web integral with both sections of the door and located in juxtaposition to the chamber formed in the jamb when the door is seated in the jamb. This jamb chamber acts to a certain extent as an expansion chamber to take up the force of the explosive charge. It will also be observed that the jamb chamber not only constitutes a receiving means for the web, but also constitutes an efficient means for insuring uniformity in the metal of the body around the door, so that should it be desired to form the casting of unmachineable metal or manganese steel, which, as is well understood it is desirable to heat treat in order to toughen it, this can be more effectively done without the setting up of internal strains in the metal at the jamb portion, thus enabling a much larger mass of metal to be located at the jamb if for any reason this is desirable.

Obviously this same construction could be used in connection with vaults, and obviously the various details could be more or less modified without departing from the spirit and scope of this improvement. In practice the disk or block of metal shown located centrally of and connecting the door sections may be in the form of a hub should it be desired to use a spindle passing through the door, and thus there would be no communication between the chamber of the door and the exterior thereof.

I claim as my invention:

1. In a safe, a body and a door, one of said members having a wall adjacent to the door joint and the other of said members having means integral therewith and effective, under an explosive charge, to be forced

into position to engage said wall of the other member located adjacent to such means thereby to lock or secure the door to the body.

5 2. In a safe, a body having a wall adjacent to the door joint and a door, the door carrying means integral therewith and effective, under an explosive charge, to be forced into position to engage such wall of the
10 body located adjacent to such means thereby to lock or secure the door to the body.

3. In a safe, a body and a door, each having a chamber adjacent to the door joint and one of said parts carrying in juxtaposition to the chamber of the other part
15 means integral therewith and adapted to be forced, under an explosive charge, into the chamber of such other part thereby to lock or secure the door to the body.

20 4. In a safe, a body and a door, each having a chamber adjacent to the door joint and said door carrying means integral therewith and adjacent to the outer terminus of its chamber and adapted to be forced, under
25 an explosive charge, into the chamber of the body thereby to lock or secure the door to the body.

5. In a safe, a body and a door, said body having a jamb provided with a chamber communicating therewith and a door fitting
30 said jamb and having means integral therewith and back of said means a space, said means adapted to be forced, under an explosive charge, into the chamber of the jamb thereby to secure the door to the body.

6. In a safe, a body and a door, the body having a jamb provided with an annular chamber communicating with such
35 jamb and the door comprising a pair of rigidly connected sections having a chamber therebetween, and means integral therewith and located in juxtaposition to the chamber of the body and adapted, under an explosive
40 charge, to be forced into the chamber of such body thereby to secure the door to the body.

7. In a safe, a body and a door, each of an integral construction and made of un-
45 machineable metal, the body having a jamb provided with an annular chamber and the door comprising a pair of sections integrally connected with a chamber therebetween, and means integral with the door and
50 located at the outer terminus of the chamber and adapted, under an explosive charge, to be forced into the chamber of the body thereby to secure the body and door together.

8. In a safe, a body and a chambered
60 door, the body having an integral jamb portion provided with a chamber communicating with the jamb, and means integral with the door and located at the outer terminus
65 of its chamber and adapted, under an explosive charge, to be forced into the cham-

ber of the body thereby to secure or lock the door to the body, the jamb chamber having means therein for limiting the movement of such door locking means.

9. In a safe, a body and a chambered
70 door, the body having an integral jamb portion provided with a chamber communicating with the jamb, and means integral with the door and located at the outer terminus of its chamber and adapted, under an explosive
75 charge, to be forced into the chamber of the body thereby to secure or lock the door to the body, the jamb chamber having ribs therein for limiting the movement of such door locking means.

10. In a safe, a body and a door, the body having a jamb provided with a chamber and the door comprising a pair of sections rigidly connected centrally thereof to form a
80 chamber and also connected adjacent to its periphery by a web of metal adapted to be forced into such jamb chamber.

11. In a safe, a body and a door, the body having a jamb provided with an annular
85 chamber and the door comprising a pair of sections rigidly connected centrally thereof to form a chamber and also connected adjacent to its periphery by a web of metal, said web having one or more weakened portions.

12. In a safe, a body and a door, the body having a jamb provided with a chamber and the door comprising a pair of sections rigidly connected and having therebetween a
90 chamber, and a web integrally connected with the sections at the outer terminus of the chamber for closing the chamber at the edge of the door.

13. In a safe, a body and a door, the body having a jamb provided with a chamber
95 and the door comprising a pair of sections rigidly connected and having therebetween a chamber, and a web integrally connected with the sections at the outer terminus of the chamber for closing the chamber at the edge of the door, said web having
100 one or more weakened portions.

14. In a safe, a body and a door, the body having a jamb provided with a chamber
105 and the door comprising a pair of sections rigidly connected and having therebetween a chamber, and a web integrally connected with the sections at the outer terminus of the chamber for closing such chamber at the edge of the door, said web having one
110 or more weakened portions each formed by a recess in the web.

15. In a safe, a body and a circular door, the body having a circular jamb provided
115 with an annular chamber and the door comprising a pair of sections rigidly connected and having therebetween a chamber, and an annular web integrally connected with the sections at the outer terminus of the chamber for closing such chamber at the edge of
120 130

the door, said web having one or more weakened portions each formed by an annular recess in the web.

16. In a safe, a body and a door, the body having a jamb provided with a chamber and the door comprising a pair of sections rigidly connected and having therebetween a chamber, and a web integrally connected with the sections at the outer terminus of the chamber for closing the chamber at the edge of the door, said web having a pair of weakened portions formed by recesses in the web one of greater depth than the other.

17. A safe door comprising front and rear sections having a chamber therebetween, and a web of metal integral with the door for closing the chamber at the edge of the door.

18. A safe door comprising front and rear sections having a chamber therebetween, and a web of metal integral with said sections for closing the chamber at the edge of the door, said web having a weakened portion or portions.

19. A safe door comprising front and rear sections having a chamber therebetween, and a web of metal integral with said sections for closing the chamber at the edge of the door, said web having a weakened portion or portions formed by a recess or recesses in the web.

20. A safe door comprising front and rear sections having a chamber therebetween, and a web of metal integral with said sections for closing the chamber at the edge of the door, said web having a plurality of weakened portions formed by recesses in the web one of greater depth than the other.

21. A circular safe door comprising front and rear sections having a chamber therebetween, and an annular web of metal integral with said sections for closing the chamber at the edge of the door, said web having a weakened portion or portions formed by one or more annular recesses in the web adjacent to its juncture point or points with the door section or sections.

22. A safe door comprising front and rear sections having a chamber therebetween, and a web of metal integral with said sections for closing the chamber at the edge of the door, said web having weakened portions formed by annular recesses in the web adjacent to its juncture points with the door sections, the juncture point adjacent to the front door section being weaker than the juncture point of the web with the rear door section.

23. A safe door comprising front and rear sections having a chamber therebetween, a web of metal integral with said sections for closing the chamber at the edge of the door, and means rigidly connecting the sections of the door interiorly thereof.

24. In a safe, an integrally formed body

having a rearwardly extending flange forming part of the jamb of the body and providing a recess adjacent to such flange, said jamb having a chamber around the same, and an integral door formed of front and rear sections connected by a web of metal forming a chamber between said sections.

25. In a safe, an integrally formed body having a rearwardly extending flange forming part of the jamb of the body and providing a recess adjacent to such flange, said jamb having a chamber around the same, and an integral door formed of front and rear sections connected by an annular web of metal forming a chamber between said sections, said annular web being located adjacent to the edge of the door for closing the chamber between the door sections.

26. In a safe, an integrally formed body having a rearwardly extending flange forming part of the jamb of the body and providing a recess adjacent to such flange, said jamb having a chamber around the same, and an integral door formed of front and rear sections connected by an annular web of metal forming a chamber between said sections, said annular web being located adjacent to the edge of the door for closing the chamber between the door sections, and said web having a weakened portion or portions.

27. In a safe, an integral body and an integral rotary door, the body having a circular jamb provided with a chamber around the same opening at the jamb, the door formed of a front and a rear section connected by an integral web of metal adjacent to the edge thereof and forming a chamber between the sections of the door, and cooperating locking means carried by the door and jamb.

28. In a safe, an integral body and an integral rotary door, the body having a circular jamb provided with a chamber around the same opening at the jamb, the door formed of a front and a rear section connected by an integral web of metal adjacent to the edge thereof and forming a chamber between the sections of the door, and cooperating locking lugs carried by the door and jamb.

29. In a safe, an integral body and an integral rotary door, the body having a circular jamb provided with a chamber around the same opening at the jamb, the door formed of a front and a rear section connected by an integral web of metal adjacent to the edge thereof and forming a chamber between the sections of the door, and cooperating locking lugs carried by the door and jamb in the rear of the door chamber and at the inner terminus of the door joint.

30. In a safe, a body having a jamb and a door fitting said jamb, one of said members having adjacent to the door joint a part extending transversely to the axis of the door

70

75

80

85

90

95

100

105

110

115

120

125

130

and the other member having within the plane of such joint integral means adapted to be forced under an explosive charge into position to engage such transversely extending part of the other of said members thereby to more securely lock the door in position.

31. In a safe, a body having a part extending transversely to the axis of the door, and a compound door comprising a pair of sections rigidly connected one to the other by an integral web of metal located adjacent to the edge of the door and adapted to be projected, under an explosive charge, into position to engage such transversely extending part of the body and more securely lock the door in position.

32. In a safe, a body having a part extending transversely to the axis of the door, and a door, the door having located within

its edge integral means adapted to be forced, under an explosive charge, into position to engage such transversely extending part of the body located adjacent to such door edge thereby to more securely lock the door in position.

33. In a safe, an integral circular body and an integral door, the body having a circular jamb provided with a chamber therein and the door comprising a pair of sections having a chamber therebetween and united at its edge by an annular integral web located in juxtaposition to the chamber in the jamb.

SAMUEL W. FISH.

Witnesses:

A. F. TRIMMER,
E. F. CONNOLLY.

Copies of this patent may be obtained for five cents each, by addressing the "Commissioner of Patents, Washington, D. C."