

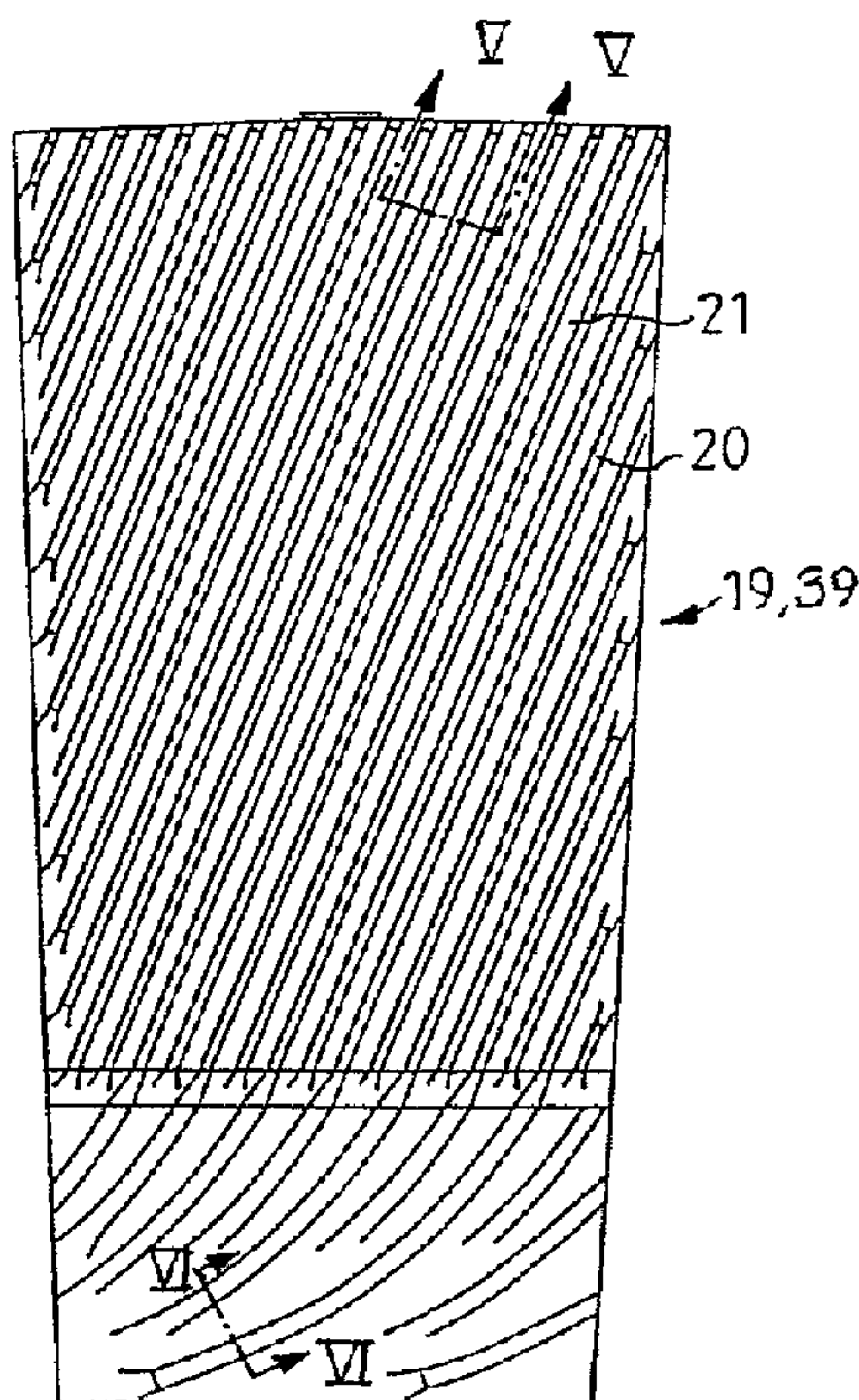

(86) Date de dépôt PCT/PCT Filing Date: 1996/12/04
 (87) Date publication PCT/PCT Publication Date: 1997/07/03
 (45) Date de délivrance/Issue Date: 2005/02/08
 (85) Entrée phase nationale/National Entry: 1998/06/02
 (86) N° demande PCT/PCT Application No.: SE 1996/001594
 (87) N° publication PCT/PCT Publication No.: 1997/023291
 (30) Priorités/Priorities: 1995/12/21 (9504608-2) SE;
 1996/06/18 (9602412-0) SE

(51) Cl.Int.⁶/Int.Cl.⁶ D21D 1/30
 (72) Inventeurs/Inventors:
 BERGQUIST, PETER, SE;
 HAWEN, ANDERS, SE;
 VIRVING, NILS, SE
 (73) Propriétaire/Owner:
 VALMET FIBERTECH AKTIEBOLAG, SE
 (74) Agent: FETHERSTONHAUGH & CO.

(54) Titre : ELEMENT DE RAFFINAGE
 (54) Title: REFINING ELEMENT



(57) **Abrégé/Abstract:**

Refining element intended for a refiner with flat or conical opposed refining surfaces, which are rotary relative to each other for working and refining lignocellulosic material during its passage through a refiner gap (15, 35) between the opposed refining surfaces from an inlet portion with smaller diameter to an outlet portion with greater diameter. The refining element (19, 39) is formed with a refining surface with bars (20) and intermediate grooves (21) which extend over the entire refining element. The bars (20) in the inlet portion of the refining element (19) form an angle of 50-85° with the radius or generatrix of the refining surface. The angle decreases along the surface of the refining element (19, 39) so that the bars (20) in the outlet portion form an angle between -25° and +25° with the radius or generatrix. The bars (20) in the inlet portion are located at a greater mutual distance than in the outlet portion.



PCT

WORLD INTELLECTUAL PROPERTY ORGANIZATION
International Bureau

INTERNATIONAL APPLICATION PUBLISHED UNDER THE PATENT COOPERATION TREATY (PCT)

<p>(51) International Patent Classification ⁶ : B02C 7/12, D21B 1/14, D21D 1/30</p>	A1	<p>(11) International Publication Number: WO 97/23291</p> <p>(43) International Publication Date: 3 July 1997 (03.07.97)</p>					
<p>(21) International Application Number: PCT/SE96/01594</p> <p>(22) International Filing Date: 4 December 1996 (04.12.96)</p> <p>(30) Priority Data:</p> <table border="0"> <tr> <td>9504608-2</td> <td>21 December 1995 (21.12.95)</td> <td>SE</td> </tr> <tr> <td>9602412-0</td> <td>18 June 1996 (18.06.96)</td> <td>SE</td> </tr> </table> <p>(71) Applicant (for all designated States except US): SUNDS DEFI-BRATOR INDUSTRIES AB [SE/SE]; S-851 94 Sundsvall (SE).</p> <p>(72) Inventors; and</p> <p>(75) Inventors/Applicants (for US only): VIRVING, Nils [SE/SE]; Backtimjegränd 27, S-165 73 Hässelby (SE). BERGQUIST, Peter [SE/SE]; Myrmalmsringen 1, S-136 65 Haninge (SE). HA'WÉN, Anders [SE/SE]; Stallvägen 34, S-135 43 Tyresö (SE).</p> <p>(74) Agent: SUNDQVIST, Hans; Sunds Defibrator Industries AB, Strandbergsgatan 61, S-112 51 Stockholm (SE).</p>	9504608-2	21 December 1995 (21.12.95)	SE	9602412-0	18 June 1996 (18.06.96)	SE	<p>(81) Designated States: AU, BR, CA, JP, NO, NZ, US, European patent (AT, BE, CH, DE, DK, ES, FI, FR, GB, GR, IE, IT, LU, MC, NL, PT, SE).</p> <p>Published With international search report.</p>
9504608-2	21 December 1995 (21.12.95)	SE					
9602412-0	18 June 1996 (18.06.96)	SE					

(54) Title: REFINING ELEMENT

(57) Abstract

Refining element intended for a refiner with flat or conical opposed refining surfaces, which are rotary relative to each other for working and refining lignocellulosic material during its passage through a refiner gap (15, 35) between the opposed refining surfaces from an inlet portion with smaller diameter to an outlet portion with greater diameter. The refining element (19, 39) is formed with a refining surface with bars (20) and intermediate grooves (21) which extend over the entire refining element. The bars (20) in the inlet portion of the refining element (19) form an angle of 50-85° with the radius or generatrix of the refining surface. The angle decreases along the surface of the refining element (19, 39) so that the bars (20) in the outlet portion form an angle between -25° and +25° with the radius or generatrix. The bars (20) in the inlet portion are located at a greater mutual distance than in the outlet portion.

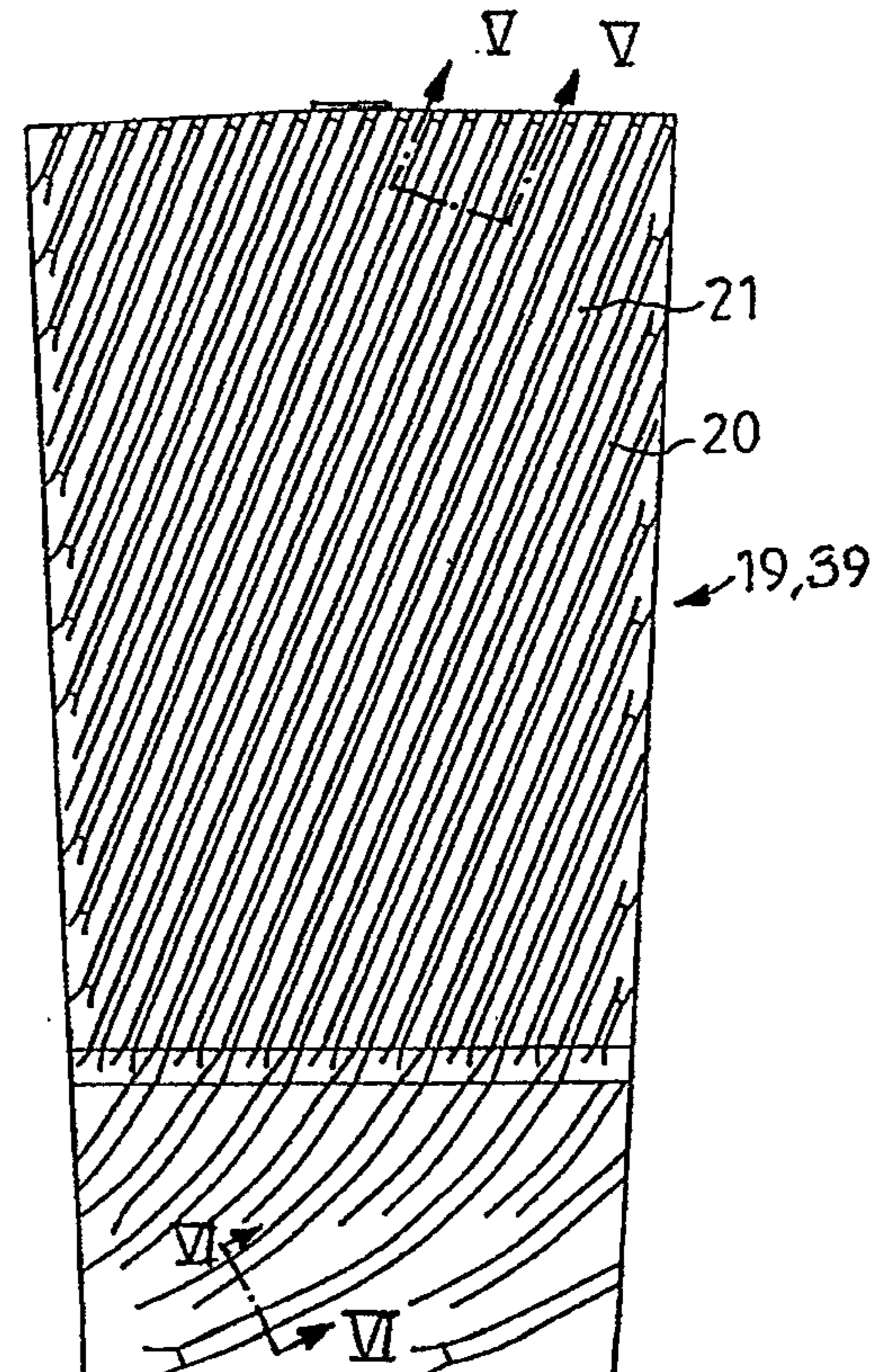

This invention relates to refining elements for use in refiners with flat or conical refining surfaces. This type of refiners is used for working and refining lignocellulosic fiber material of both low and high material concentration.

Refiners with flat refining surfaces comprise two refining discs, rotating relative to each other, having opposed refining surfaces. Thereby, one refining disc can be rotating and the other stationary or both can be rotating in opposite directions. The refining surfaces consist of refining elements located on each refining disc. These refining elements are provided with a pattern of bars and intermediate grooves. Between the opposed refining elements a refiner gap is formed, through which the material is intended to pass outwards while simultaneously being worked by the bars of the refining elements.

Refiners with conical refining surfaces comprise a rotor with conical refining surface which is surrounded by a stator with an opposed conical refining surface. The angle of inclination to the rotor axis is less than 45° , preferable $10-30^{\circ}$. The refining surfaces consist of refining elements located on the rotor and, respectively, stator. These refining elements are provided with a pattern of bars and intermediate grooves. Between the opposed refining elements a refiner gap is formed, through which the material is intended to pass from the end with the smallest diameter to the end with the largest diameter while simultaneously being worked by the bars of the refining elements.

The bars on the refining elements can be straight or angled, and the bar-groove ratio can be varied for achieving different refining results. The feed through the refiner gap is affected strongly by the centrifugal force. With increasing diameter in the feed direction, the centrifugal force and thereby the feed force, also increase. The difference in diameter between the inlet and outlet of the refiner gap implies that the space for the material in the refiner gap can vary by up to 50% between the inlet and outlet portion of the refiner gap. These conditions limit the capacity and can cause problems with non-uniform quality of the refined material. Besides, there will also be a reduction in production due to wear of the bars on the refining elements.

The present invention has the object to eliminate these problems by

28229-93

2

bringing about a uniform feed through the entire refiner gap.

According to the present invention, there is provided a refining element intended for a refiner with
5 opposed refining surfaces, which are rotary relative to each other for working and refining lignocellulosic material during the passage of the material through a refiner gap (15,35) between the opposed refining surfaces from an inlet portion with smaller diameter to an outlet portion with
10 greater diameter, which refining element (19,39) is formed with a refining surface with bars (20) and intermediate grooves (21) which extend over the entire refining element, characterized in that the bars (20) in the inlet portion of the refining element (19,39) form an angle of $50-85^\circ$ with a
15 generatrix of the refining surface, and that the angle decreases outwards along the surface of the refining element (19,39), so that the bars (20) in the outlet portion form an angle between -25° and $+25^\circ$ with the generatrix, and that the bars (20) in the inlet portion are located at a greater
20 mutual distance than in the outlet portion.

A more uniform material flow through the gap of the refiner can be obtained by forming the inlet portion of the refining elements more open and angular after the flow direction of the pulp. The refining result as well as the
25 production are hereby improved. An increase in capacity as well as the production are hereby improved. An increase in capacity of 20-25% has proved possible to obtain.

The invention is described in greater detail in the following, with reference to the accompanying drawings
30 illustrating an embodiment of a refining element according to the invention.

28229-93

2a

Fig. 1 is a section through a refiner with flat refining discs;

Fig. 2 is a section through a conical refiner;

Fig. 3 shows a refining element according to the invention;

Fig. 4 shows a different design of a refining element according to the invention;

Fig. 5 is a section according to V-V in Figs. 3 and 4;

Fig. 6 is a section according to VI-VI in Figs. 3 and 4.

The refiner with flat refining surfaces shown in Fig. 1 comprises a rotary refining disc (rotor) 10 on a shaft 11 supported in bearings 12,13. A stationary refining disc (stator) 14 is arranged opposite the rotary refining disc 10 so that a refiner gap 15 is formed between the refining surfaces on the rotor 10 and stator 14. The rotor 10 as well as the stator 14 are enclosed in an airtight casing 16, which has a central inlet 17 through the stator 14 inside the refiner gap for the material to be worked, and an outlet 18 for the refined material outside the refiner gap. The working is brought about by the relative rotation between the refining surfaces.

The shaft 11 is movable for adjusting the size of the refiner gap 15 and for producing the required pressure between the refining surfaces.

The refiner shown in Fig. 2 comprises a rotor 30 on a rotary shaft 31 supported in bearings 32,33. The rotor 30 is surrounded by a stator 34, in such

a way, that a conical refiner gap 35 is formed between the refining surfaces on the rotor 30 and stator 34. The rotor 30 as well as the stator 34 are enclosed in an airtight casing 36, which has an inlet 37 at the narrower end of the conical refiner gap for the material to be worked, and an outlet 38 for the refined material at the opposite end. The working is brought about by the relative rotation between the refining surfaces.

The shaft 31 is movable for adjusting the size of the refiner gap 35 and for producing the required pressure between the refining surfaces.

In the refiners according to fig. 1 and 2, respectively, the rotor 10,30 and stator 14,34 are provided with a plurality of refining elements 19,39. Each element 19,39 is formed with a refining surface comprising bars 20 and intermediate grooves 21 which extend substantially over the entire refining surface. At the portion of the refining elements intended to be located closest to the inlet, the bars 20 form an angle of $50-85^{\circ}$, preferably $60-80^{\circ}$, with the radius or generatrix of the refining surface. This angle decreases, preferably successively, along the surface of the refining element 19,39 so that the bars 20 at the outlet portion form an angle between -25° and $+25^{\circ}$ with the radius or generatrix. According to Fig. 3, each bar 20 forms a bow with successively decreasing angle from the inlet portion to the outlet portion. The total cross-sectional area of the grooves 21 in the inlet portion should substantially correspond to the total cross-sectional area of the grooves in the outlet portion. Fig. 5 and, respectively, Fig. 6 are cross-sections of the outlet and, respectively, inlet portion of the refining element 19,39. This implies that the bars 20 in the inlet portion should be located at a greater mutual distance than in the outlet portion.

The design of the refining elements 19,39 has the object to bring about a uniform feed through the refiner gap. In the inlet portion of the refining element the centrifugal force, and thereby its feeding effect on the material, is at the lowest. Owing to the increasing centrifugal force, the feeding force increases along the refiner gap 15,35. Due to the angular shape of the bars 20, the feeding force varying in response to the centrifugal force can be compensated for so that a substantially uniform feed along the entire length of the refining element 19,39

is obtained. This implies that the pumping effect of the bars decreases outward, and it even can be negative, i.e. braking, in the outlet end of the refining element. See Fig. 4.

For obtaining uniform feed, it is also necessary that the free inlet volume in the refiner gap 15,35 substantially corresponds to the free outlet volume. This can be achieved by arranging the bars 20 more sparsely in the inlet portion. The total cross-sectional area of the gooves 21 in the inlet portion can substantially correspond to the total cross-sectional area of the grooves in the outlet portion.

The invention, of course, is not restricted to the embodiments shown, but can be varied within the scope of the invention idea.

28229-93

5

CLAIMS:

1. A refining element intended for a refiner with opposed refining surfaces, which are rotary relative to each other for working and refining lignocellulosic material during the passage of the material through a refiner gap (15,35) between the opposed refining surfaces from an inlet portion with smaller diameter to an outlet portion with greater diameter, which refining element (19,39) is formed with a refining surface with bars (20) and intermediate grooves (21) which extend over the entire refining element,

characterized in that the bars (20) in the inlet portion of the refining element (19,39) form an angle of 50-85° with a generatrix of the refining surface, and that the angle decreases outwards along the surface of the refining element (19,39), so that the bars (20) in the outlet portion form an angle between -25° and +25° with the generatrix, and that the bars (20) in the inlet portion are located at a greater mutual distance than in the outlet portion.

2. A refining element as defined in claim 1, characterized in that the total cross-sectional area of the grooves (21) in the inlet portion corresponds to the total cross-sectional area of the grooves (21) in the outlet portion.

3. A refining element as defined in claim 1 or 2, characterized in that each bar (20) forms a bow with successively decreasing angle from the inlet portion to the outlet portion.

4. A refining element as defined in any one of claims 1 to 3, characterized in that the angle of the bars (20) in the inlet portion is 60-80°.

28229-93

6

5. A refining element as defined in any one of claims 1-4, characterized in that it is designed for a refiner with flat opposed refining surfaces.

6. A refiner element as defined in any one of claims 5 1-4, characterized in that it is designed for a refiner with conical opposed refining surfaces.

FETHERSTONHAUGH & CO.

PATENT AGENTS

OTTAWA, CANADA

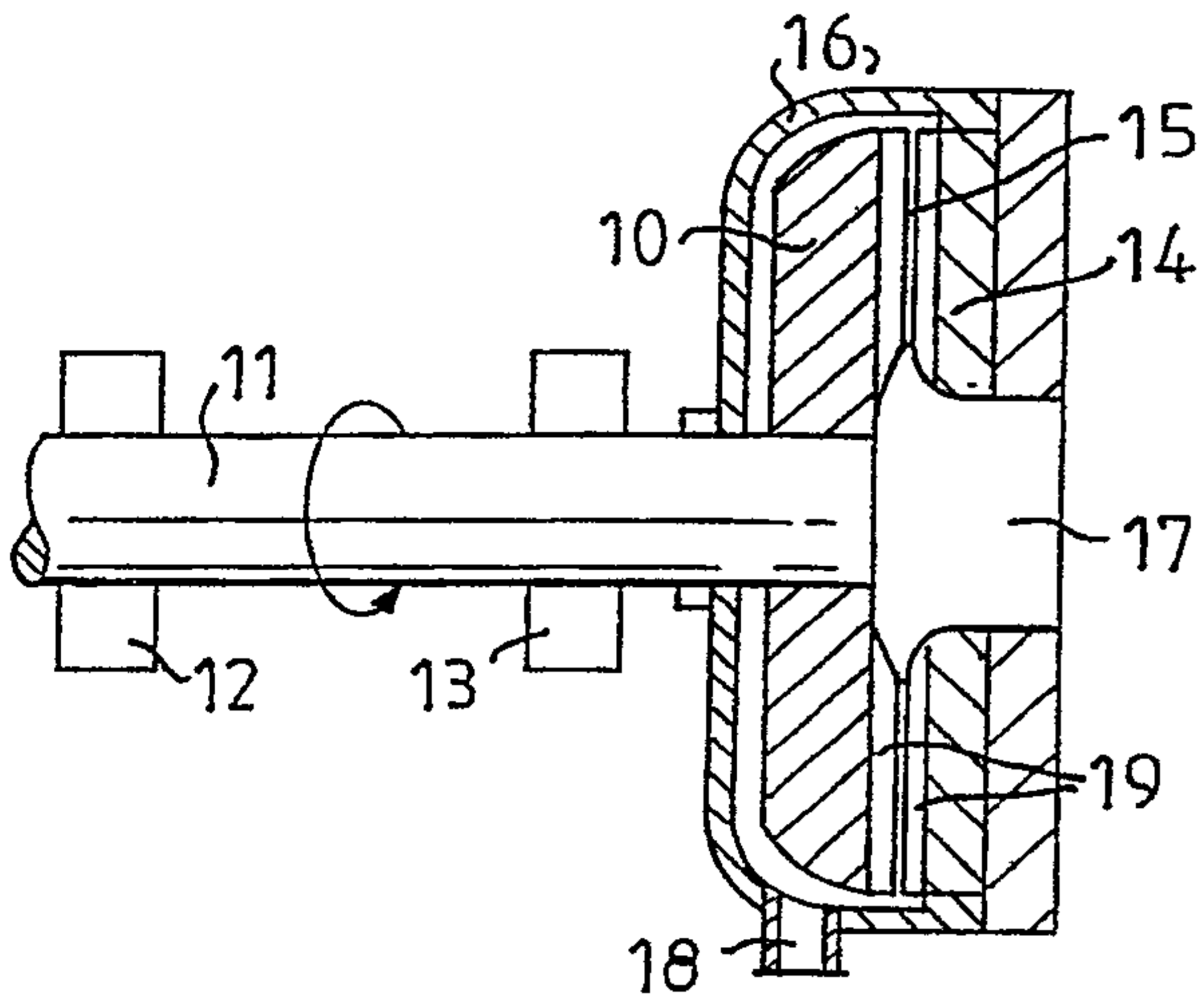

FIG. 1

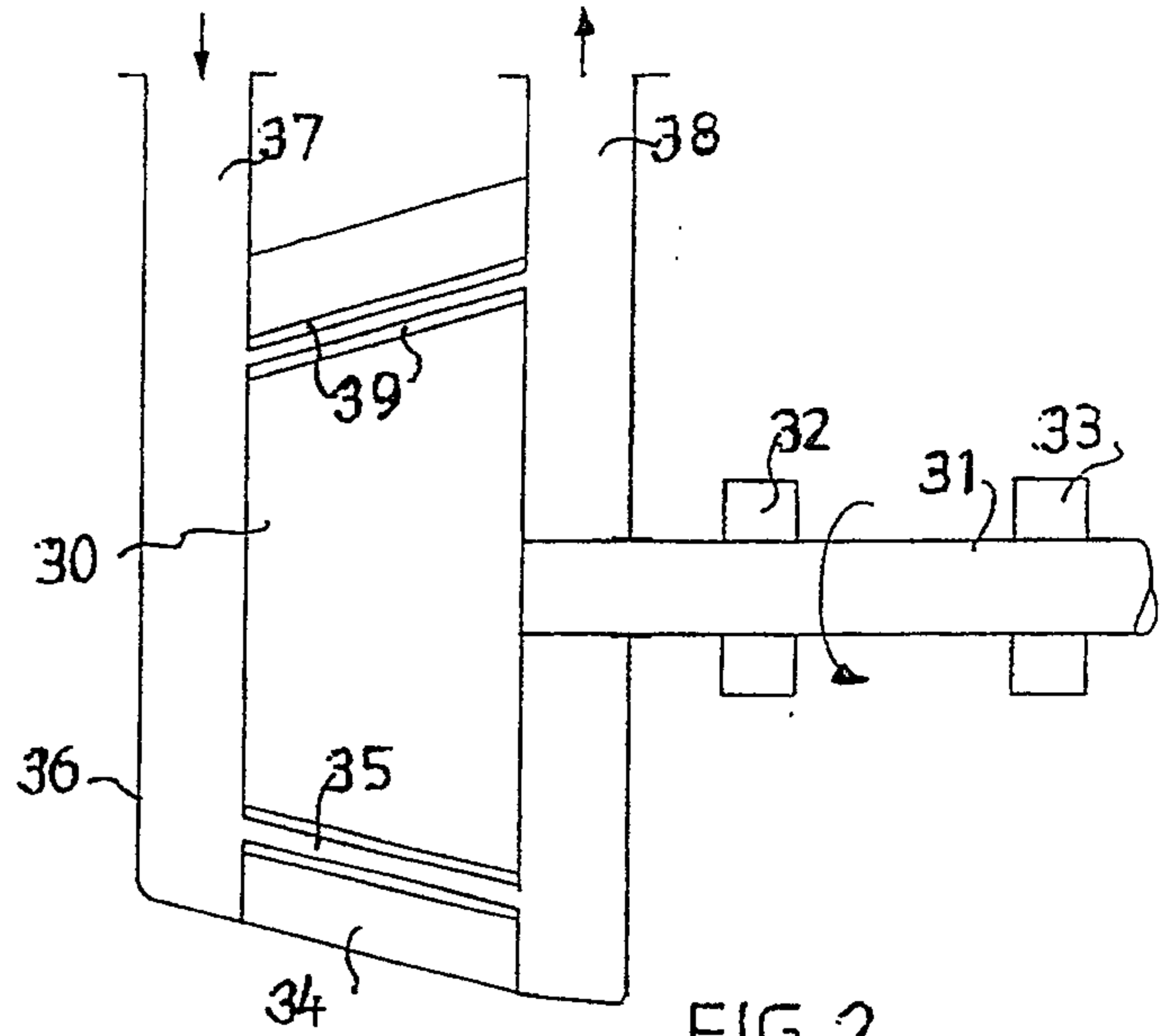

FIG. 2

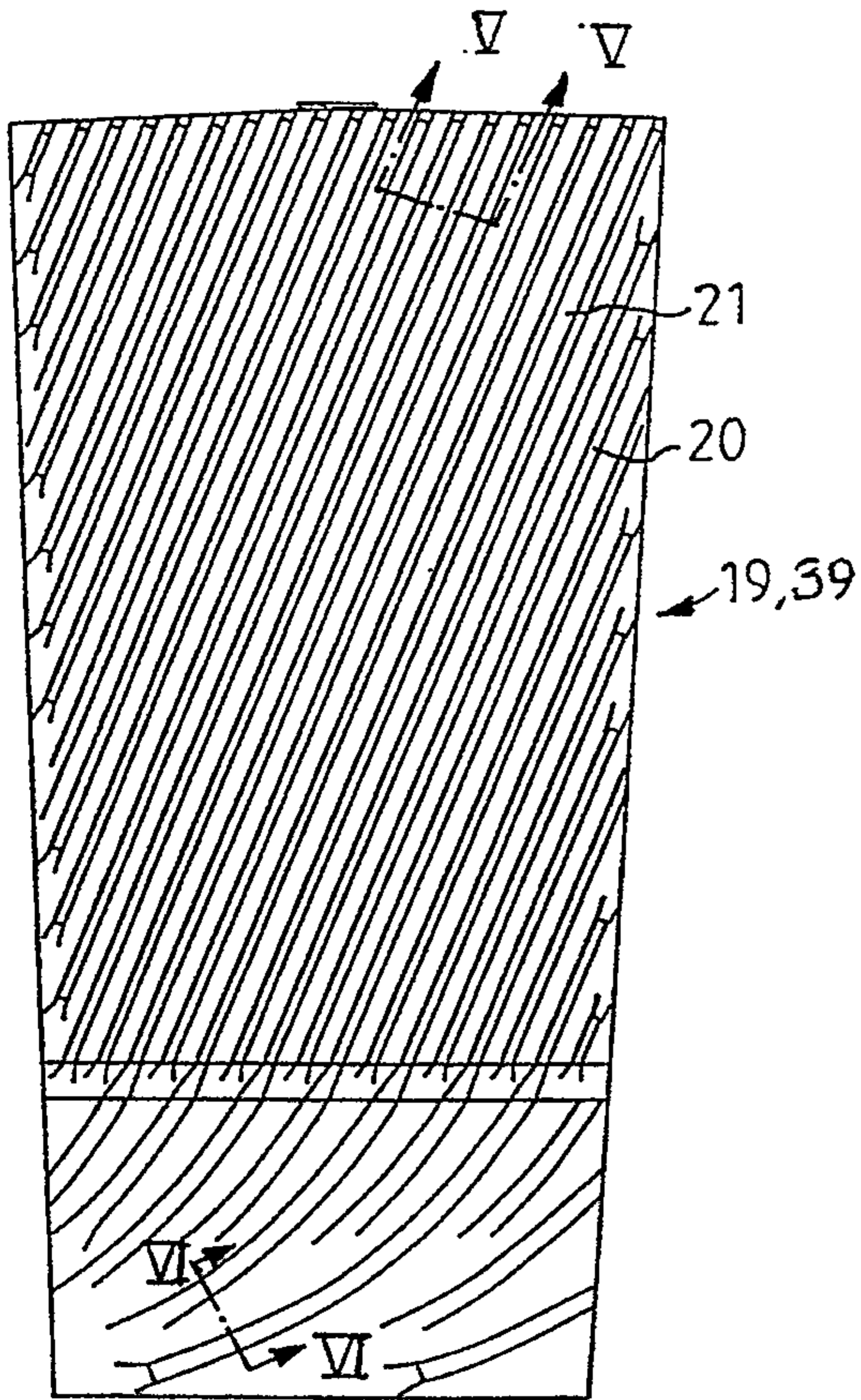

FIG. 3

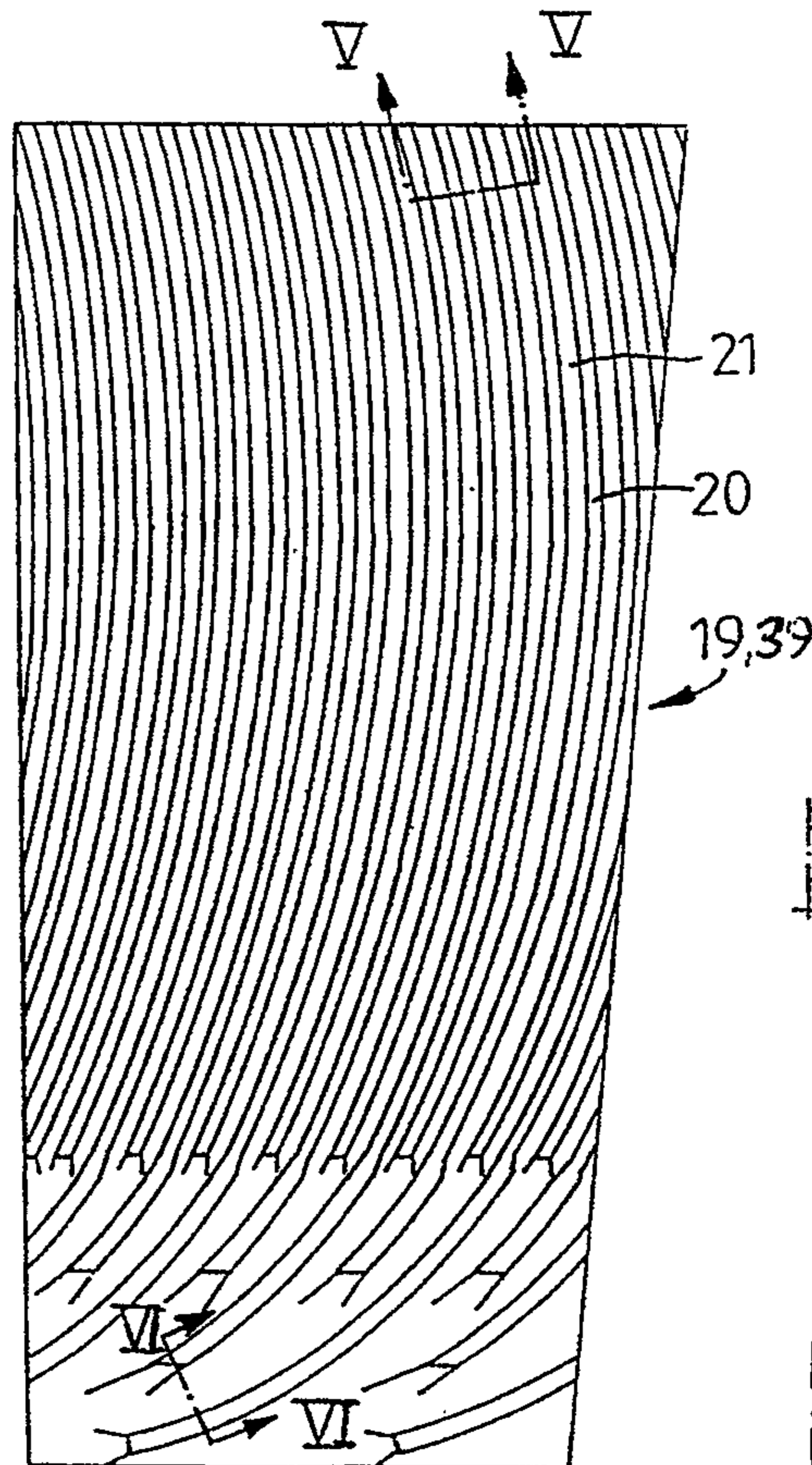

FIG. 4

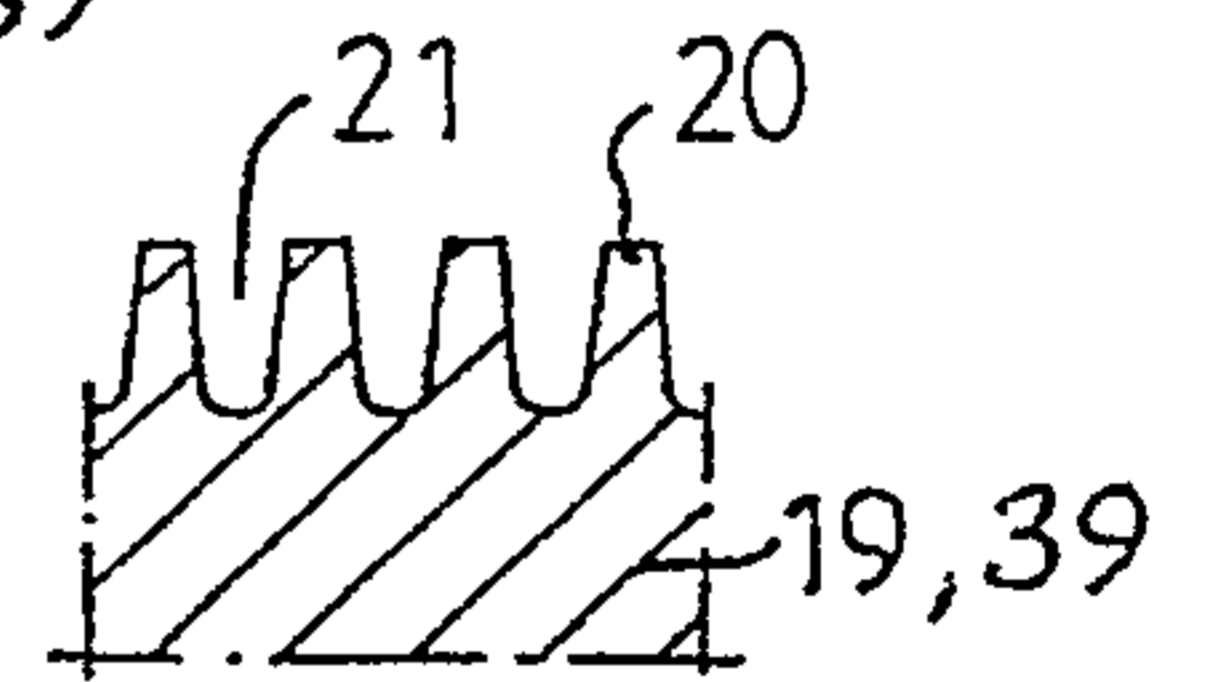

FIG. 5

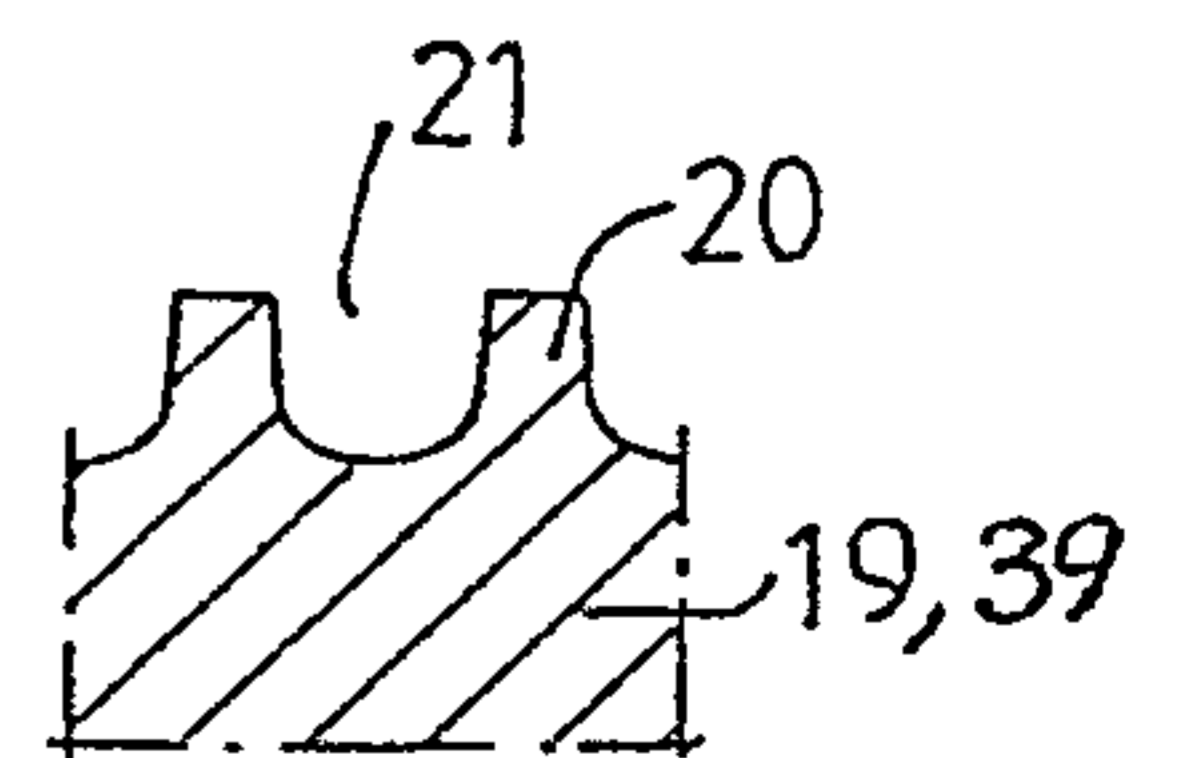

FIG. 6

