

- [54] **BLOWER WHEEL**
- [75] Inventors: **David W. Wolbrink; Robert W. Busch**, both of Hartford, Wis.
- [73] Assignee: **Broan Manufacturing Co., Inc.**, Hartford, Wis.
- [22] Filed: **Mar. 12, 1973**
- [21] Appl. No.: **339,629**
- [52] U.S. Cl. .... **416/183, 416/186, 416/187**
- [51] Int. Cl. .... **F01d 5/04**
- [58] Field of Search ..... **416/186, 187, 197, 202, 416/182, 183, 185, 188**

1,893,184	1/1933	Smellie.....	415/119 UX
2,350,939	6/1944	Sprouse .....	416/185
2,745,597	5/1956	Sinclair et al.....	416/185
2,991,004	7/1961	Denbo et al. ....	416/182 UX
3,521,973	7/1970	Schoun .....	416/185
3,692,428	9/1972	Bubb et al. ....	416/187

**FOREIGN PATENTS OR APPLICATIONS**

583,729	12/1946	Great Britain.....	415/119
---------	---------	--------------------	---------

*Primary Examiner*—Everette A. Powell, Jr.  
*Attorney, Agent, or Firm*—Andrus, Scales, Starke & Sawall

[57] **ABSTRACT**

A blower wheel of the squirrel cage type having increased efficiency includes forward curved fan blades having backward curved feeder vanes.

**5 Claims, 2 Drawing Figures**

- [56] **References Cited**
- UNITED STATES PATENTS**
- 1,427,391 8/1922 Johns..... 416/207 X
- 1,512,273 10/1924 Callahan..... 416/202 X

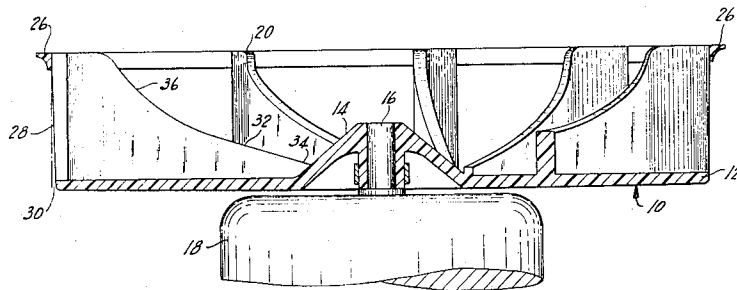

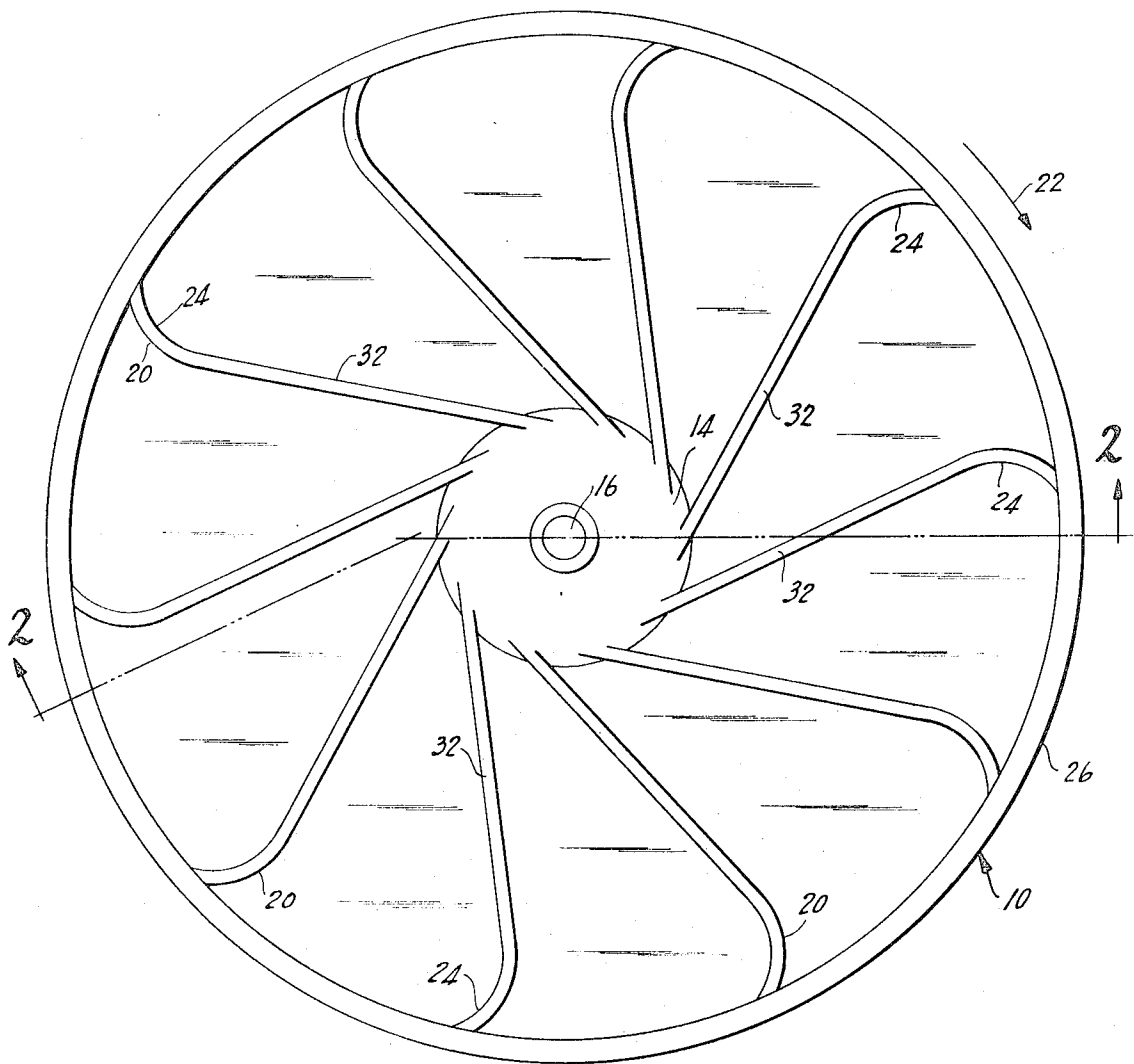

*Fig. 1*

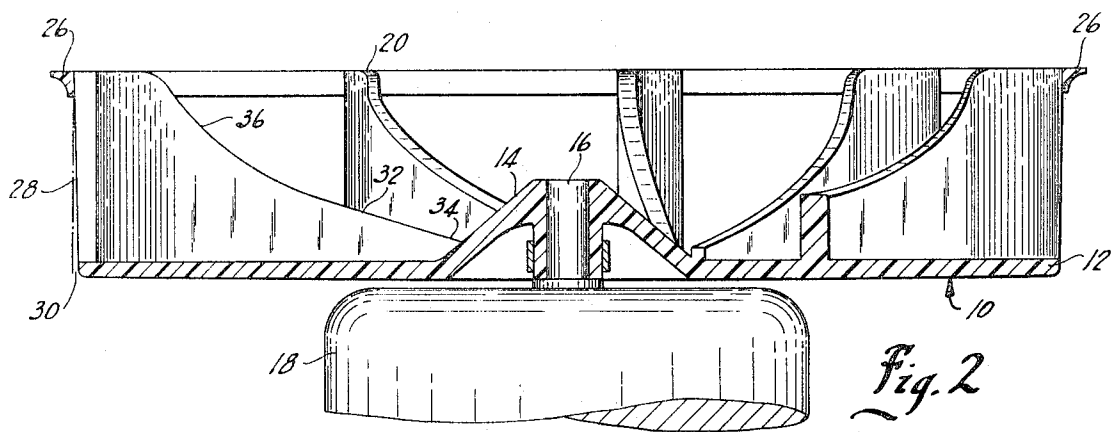

*Fig. 2*

**BLOWER WHEEL****FIELD OF THE INVENTION**

The present invention relates to the field of centrifugal fans or blowers and more specifically to the provision of a blower wheel of the forward curved type.

**SUMMARY OF THE INVENTION**

Blower wheels are typically used in centrifugal fans to move air brought in at an inlet in the center of the device to a peripheral discharge by centrifugal action. Such blower wheels include a rotary base plate on which is mounted peripherally spaced, axial fan blades, forming a so called squirrel cage. The blades increase the velocity and/or pressure of the air in its transit through the fan.

Three general blower wheel configurations are recognized. In the radial, or paddle wheel, type the fan blades lie on radii of the blower wheel base plate. In forward curved blower wheels, the blades are angularly displaced from the radial position in the direction of rotation as by moving the outer edges of the fan blades in that direction. In backward curved blower wheels, the blades are angularly displaced from the radial position against the direction of rotation.

It is an object of the present invention to provide an improved blower wheel of the forward curved type which maintains a given air delivery volume over both a wider and higher range of static pressures than has heretofore been possible.

Another feature of the present invention is to provide a forward blower wheel construction which overcomes the instabilities and inefficiencies presently found in such devices. By overcoming the inefficiencies found in prior art blower wheels, the invention permits a decrease in the power requirements for the fan or a reduction in the size and/or number of blades. Reducing the number of blades reduces the frequency of the blade noise of the fan, lessening undesirable audio effects or permitting an increase in operating speed of the fan.

In the attainment of the foregoing objects, the following features are incorporated in the blower wheel of the present invention. The forward curved blades of the blower wheel are provided with backward curved feeder vanes. The latter are highly efficient in commencing the rotation of the air stream in the blower wheel while the former serve to build desired air pressures at the outlet. Passage of the air through the blower wheel is facilitated by a conical central core and by the orientation of the blades and vane edges with respect to the air stream.

**BRIEF DESCRIPTION OF THE DRAWING**

FIG. 1 is a plan view of the blower wheel of the present invention.

FIG. 2 is a cross sectional view of the blower wheel of the present invention taken along the line 2--2 of FIG. 1 and showing the driving motor for the blower wheel.

**DESCRIPTION OF THE PREFERRED EMBODIMENT**

As shown in FIG. 1, blower wheel 10 includes a generally flat circular base 12. Base 12 includes a conical hub 14 in the center thereof suitable for receiving the output shaft 16 of electric motor 18.

A plurality of upright fan blades 20 are mounted on base 12 normal to its plane. The blades are spaced along the perimeter of the base. As shown most clearly on FIG. 1, these blades are forward curved with respect to the direction of rotation of blower wheel 10 by motor 18, as indicated by arrow 22 in FIG. 1. As such, fan blades 200 are formed so that the concave surfaces 24 thereof curve from a generally radial condition toward the direction of rotation. A stationary peripheral observer thus views the concave surfaces 24 of fan blades 20 upon rotation of the blower wheel. The upper portions of blades 20 may be linked by ring 26. The outer edges 28 of fan blades 20 taper inward in a direction toward base 12 for purposes hereinafter described, as shown at 30 in FIG. 2.

Upright feeder vanes 32 mounted on base 12 join fan blades 20 to hub 14. Feeder vanes 32 are backward curved. That is, the feeder vanes intersect constructed radii of base 12 at angles slanting away from the direction of rotation of blower wheel 10. Each feeder vane 32 thus lies along a partial non-diametric chord of circular base 12 and has one end joined to hub 14 in a generally tangential manner and the other end joined to one of fan blades 20.

In the elevational profile shown most clearly in the left hand side of FIG. 2, each feeder vane 26 includes an inner or ramp-like portion 34, the height of which increases in direct proportion to the distance from hub 14 and a flaring portion 36 which joins portion 34 to a fan blade 20 in a streamlined fashion.

In operation, blower wheel 10 is enclosed in an appropriate housing having an inlet aligned with the axis of rotation of shaft 16 and blower wheel 10 and an outlet located adjacent the periphery of blower wheel 10. Upon rotation of blower wheel 10 by motor 18, a stream of inlet air is drawn into the center of the blower wheel. The stream of air is deflected by hub 14 towards the periphery of blower wheel 10. The height and base dimensions of conical hub 14 are selected to facilitate this deflection. For this purpose, it has been found desirable to make the height of hub 14 approximately equal to the maximum height of ramp-like inner portion 34. The inner portions 30 of feeder vanes 28 by virtue of their backward curved positioning commence a spinning or eddying of the air while at the same time accelerating the air towards the periphery of blower wheel 10 by centrifugal action.

As this action occurs near the axis of rotation of the blower wheel the torque loading and power demand placed on motor 16 is lessened over that which would be imposed if no feeder vanes were used and the peripheral blades were employed for this purpose. It has been found that while the reduced height of inner portions 34 assists in reducing torque loading on the motor, it does not lessen the effectiveness of the feeder vanes in initiating movement of the air.

As the air accelerated by the feeder vanes approaches the periphery of base 12, it is picked up by fan blades 20 and discharged at the perimeter of blower wheel 10 into the outlet.

The elevational path of the air stream in the radial direction is a gently curving arc from a direction normal to base 12 to a discharge direction oriented at an acute angle to the plane of the base. To obtain maximum efficiencies, it has been found desirable to have the upper edges of feeder vanes 32 lie perpendicular to the stream of inlet air. This is accomplished by the ramp-

like configuration of feeder vane portions 34. For the same reason, it has been found desirable to have the external edges 28 of fan blades 20 lie perpendicular to the stream of outlet air. Edges 25 thus taper toward base 12. The amount of taper may typically be 1 1/2°.

Various modes of carrying out the invention are contemplated as being within the scope of the following claims particularly pointing out and distinctly claiming the subject matter which is regarded as the invention.

We claim:

1. A motor driven, rotary blower wheel comprising:

a flat circular base lying in a plane perpendicular to the axis of rotation and to a stream of inlet air;

a plurality of uniformly spaced fan blades mounted on the perimeter of said base normal to its plane, said fan blades being forward curved with respect to the direction of rotation of said blower wheel for exhausting a peripheral stream of outlet air;

a conical hub mounted in the center of said base, said hub being of a size sufficient to form, with said base, a means for diverting the stream of air through the blower wheel; and

a plurality of backward curved feeder vanes mounted on said base normal to its plane, said vanes extend-

ing between said hub and said blades along portions of non-diametrical chords of said base and having ends joined to said hub in a generally tangential manner, said vanes further having ramplike inner portions for providing an initial spin to the air stream while avoiding torque loading of the motor and flaring portions joining said blades.

2. The blower wheel according to claim 1 wherein the ramp-like inner portions of said feeder vanes increase in height in direct proportion to the distance from the hub toward the fan blades.

3. The blower wheel according to claim 2 wherein the ramp-like inner portions have slanting upper edges disposed normal to the stream of air diverted through the blower wheel.

4. The blower wheel according to claim 1 wherein said fan blades exhaust the peripheral stream of outlet air at an acute angle with respect to the base and said fan blades have edges perpendicular to the stream of exhaust air and disposed at an angle to said base.

5. The blower wheel according to claim 3 wherein said conical hub has a height approximately equal to the maximum height of the ramp-like inner portions of said feeder vanes.

\* \* \* \* \*

30

35

40

45

50

55

60

65