



INTERNATIONAL APPLICATION PUBLISHED UNDER THE PATENT COOPERATION TREATY (PCT)

<p>(51) International Patent Classification <sup>6</sup> : <b>B41J 2/505, 2/515, G06K 15/10</b></p>	<p><b>A1</b></p>	<p>(11) International Publication Number: <b>WO 97/31781</b> (43) International Publication Date: 4 September 1997 (04.09.97)</p>
<p>(21) International Application Number: PCT/IL97/00071 (22) International Filing Date: 25 February 1997 (25.02.97) (30) Priority Data: 117278 27 February 1996 (27.02.96) IL (71) Applicant (for all designated States except US): IDANIT TECHNOLOGIES LTD. [IL/IL]; 38 Eliyahu Eitan Street, New Industrial Area, 75150 Rishon Lezion (IL). (72) Inventors; and (75) Inventors/Applicants (for US only): ADLER, Uri [IL/IL]; 36 Kdoshei Kahir Street, 58363 Holon (IL). MILLER, Gershon [IL/IL]; 1 Hefetz Haim Street, 76217 Rehovot (IL). (74) Agent: REINHOLD COHN AND PARTNERS; P.O. Box 4060, 61040 Tel-Aviv (IL).</p>	<p>(81) Designated States: AL, AM, AT, AU, AZ, BA, BB, BG, BR, BY, CA, CH, CN, CU, CZ, DE, DK, EE, ES, FI, GB, GE, HU, IL, IS, JP, KE, KG, KP, KR, KZ, LC, LK, LR, LS, LT, LU, LV, MD, MG, MK, MN, MW, MX, NO, NZ, PL, PT, RO, RU, SD, SE, SG, SI, SK, TJ, TM, TR, TT, UA, UG, US, UZ, VN, YU, ARIPO patent (KE, LS, MW, SD, SZ, UG), Eurasian patent (AM, AZ, BY, KG, KZ, MD, RU, TJ, TM), European patent (AT, BE, CH, DE, DK, ES, FI, FR, GB, GR, IE, IT, LU, MC, NL, PT, SE), OAPI patent (BF, BJ, CF, CG, CI, CM, GA, GN, ML, MR, NE, SN, TD, TG).</p> <p><b>Published</b> <i>With international search report. Before the expiration of the time limit for amending the claims and to be republished in the event of the receipt of amendments.</i></p>	

(54) Title: METHOD FOR OPERATING AN INK JET PRINTER

(57) Abstract

A method of operation for an ink jet printer having a print head with a plurality of spaced apart ink jet heads, the ink jet printer printing an image on a substrate at a pre-determined line resolution, thereby defining an inter ink dot line separation gap between adjacent ink dot lines on the image, the method comprising the steps of: (a) positioning the print head relative to the substrate such that at least one ink jet head lies in an operative printing position over the substrate; (b) actuating at least one ink jet head overlying the substrate during displacement of the print head relative to the substrate in a first direction so as to print a corresponding number of ink dot lines on the substrate in a manner determined by the appearance of the image to be printed; (c) displacing the print head relative to the substrate in a second direction substantially transverse to the first direction through a step greater than the inter ink dot line separation gap; and (d) repeating steps (b) and (c) so as to print the entire image on the substrate.

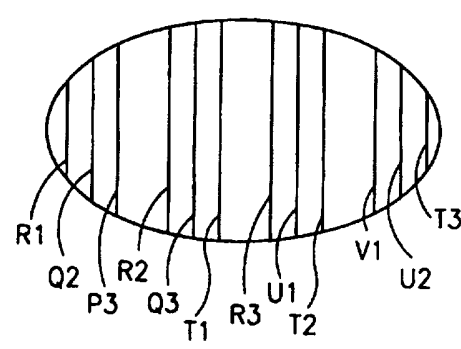
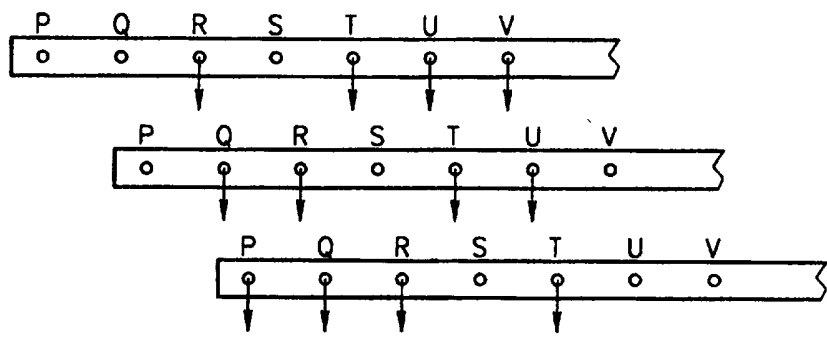

**FOR THE PURPOSES OF INFORMATION ONLY**

Codes used to identify States party to the PCT on the front pages of pamphlets publishing international applications under the PCT.

AM	Armenia	GB	United Kingdom	MW	Malawi
AT	Austria	GE	Georgia	MX	Mexico
AU	Australia	GN	Guinea	NE	Niger
BB	Barbados	GR	Greece	NL	Netherlands
BE	Belgium	HU	Hungary	NO	Norway
BF	Burkina Faso	IE	Ireland	NZ	New Zealand
BG	Bulgaria	IT	Italy	PL	Poland
BJ	Benin	JP	Japan	PT	Portugal
BR	Brazil	KE	Kenya	RO	Romania
BY	Belarus	KG	Kyrgystan	RU	Russian Federation
CA	Canada	KP	Democratic People's Republic of Korea	SD	Sudan
CF	Central African Republic	KR	Republic of Korea	SE	Sweden
CG	Congo	KZ	Kazakhstan	SG	Singapore
CH	Switzerland	LI	Liechtenstein	SI	Slovenia
CI	Côte d'Ivoire	LK	Sri Lanka	SK	Slovakia
CM	Cameroon	LR	Liberia	SN	Senegal
CN	China	LT	Lithuania	SZ	Swaziland
CS	Czechoslovakia	LU	Luxembourg	TD	Chad
CZ	Czech Republic	LV	Latvia	TG	Togo
DE	Germany	MC	Monaco	TJ	Tajikistan
DK	Denmark	MD	Republic of Moldova	TT	Trinidad and Tobago
EE	Estonia	MG	Madagascar	UA	Ukraine
ES	Spain	ML	Mali	UG	Uganda
FI	Finland	MN	Mongolia	US	United States of America
FR	France	MR	Mauritania	UZ	Uzbekistan
GA	Gabon			VN	Viet Nam

## Method for operating an ink jet printer

### FIELD OF THE INVENTION

The present invention relates to a method of operation for direct computer-to-print printing systems in general and ink jet printers in particular.

5

### BACKGROUND OF THE INVENTION

Ink jet printers are either of the flat-bed type or the rotatable drum type. Irrespective of its type, an ink jet printer prints parallel ink dot lines on a substrate by displacing its print head relative to a substrate in a first direction during the actuation of its ink jet heads. The desired line resolution of an image is typically an order of magnitude greater than the conventional inter ink jet head separation gap. Thus, in order to print an image of a desired line resolution, each ink jet head is required to print a number of ink dot lines equal to the ratio between the inter ink jet head separation gap and the desired line resolution, both parameters being provided in the same units, for example, inches. In practice, this is achieved by intermittently advancing the print head relative to a substrate in a second direction perpendicular to the first direction through one or more steps and actuating the ink jet jets at each of their new positions whilst displacing the print head relative to a substrate in the first direction.

10

15  
20

- 2 -

In the case of a rotatable drum type ink jet printer, the above described method of operation is implemented by its print head extending parallel to the substrate bearing drum's shaft for printing parallel ink dot lines on a substrate on each rotation of the drum and by advancing the print head along the drum between consecutive drum rotations. Figure 1 shows an ellipse shaped image printed during three drum rotations of such an ink jet printer having 5 ink jet heads labelled A, B, C, D and E. For convenience, the ink dot lines printed by the different ink jet heads during each consecutive drum rotation are denoted by the reference numbers 1, 2 and 3. It can be readily appreciated that the image suffers from the drawback that a single defective ink jet head C having, say, a blocked nozzle, causes an unprinted band of a width equal to the inter ink jet head separation gap.

It is the object of the present invention to substantially overcome this and other disadvantages.

#### SUMMARY OF THE INVENTION

In accordance with the teachings of the present invention, there is provided a method of operation for an ink jet printer having a print head with a plurality of spaced apart ink jet heads, the ink jet printer printing an image on a substrate at a predetermined line resolution, thereby defining an inter ink dot line separation gap between adjacent ink dot lines on the image, the method comprising the steps of:

- (a) positioning the print head relative to the substrate such that at least one ink jet head lies in an operative printing position over the substrate;
- (b) actuating at least one ink jet head overlying the substrate during displacement of the print head relative to the substrate in a first direction so as to print a corresponding number of ink dot lines on the substrate in a manner determined by the appearance of the image to be printed;
- (c) displacing the print head relative to the substrate in a second direction substantially transverse to the first direction

- 3 -

through a step greater than the inter ink dot line separation gap; and

- (d) repeating steps (b) and (c) so as to print the entire image on the substrate.

5           In accordance with the teachings of the present invention, the displacement of the print head relative to the substrate through a step greater than the inter ink dot line separation gap entails that adjacent ink dot lines are printed by different ink jet heads. The main advantage provided for by this method of operation is that in the case of an inoperative ink jet head,  
10 the ink dot lines which it should have printed are spaced out along the image rather than being adjacent to one another in an unprinted band as hitherto occurs with a conventional ink jet printer as described hereinabove such that their detrimental effect on image quality is considerably less noticeable.

15           This method of operation requires a longer print head for printing the same size image as a conventional ink jet printer. This is because, at any one time, one or more ink jet heads are positioned in inoperative printing positions either to the left or right of a substrate. Thus, during the printing of an image, some or all of the ink jet heads in initially inoperative  
20 printing positions are displaced to operative printing positions whilst some or all of the ink jet heads in initially operative printing positions are displaced to inoperative printing positions. Some conventional ink jet printers can be retro-fitted so as to operate in the above described manner for printing narrower than usual images.

25           The spacing between consecutive ink dot lines printed by a particular ink jet head, i.e. the length of the step "y" by which a print head is displaced relative to a substrate in the second direction, is not arbitrary but rather must comply with a number of constraints as now described assuming that all parameters are in the same units. The first constraint to  
30 be complied with is that the spacing between consecutive ink dot lines of a particular ink jet head is equal to a multiple of the separation gap "a" between adjacent ink dot lines at a desired line resolution, namely,

$y = m_1 \times a$  where  $m_1$  is a natural number greater than one. The second constraint to be complied with is that the spacing between consecutive ink dot lines of a particular ink jet head is not equal to a multiple of the inter ink jet head separation gap "b", namely,  $y \neq m_2 \times b$  where  $m_2$  is a natural number greater than zero, such that ink jet heads do not assume previously occupied positions relative to a substrate. The third constraint to be complied with and which also applies to conventional ink jet printers is that the inter ink jet head separation gap "b" is a multiple of the inter ink dot line separation gap "a" at a particular desired line resolution, namely,  $b = m_3 \times a$  where  $m_3$  is a natural number greater than zero. However, in addition, in view of the first constraint  $y = m_1 \times a$ , also  $m_1 > m_3$  and  $m_1$  and  $m_3$  do not have a common denominator such that ink jet heads do not assume previously occupied positions.

In line with conventional practice, an ink jet printer operative in accordance with the teachings of the present invention can preferably print at one or more preset line resolutions, for example, a low line resolution of, say, 40 lpi or a high line resolution of, say, 60 lpi, the trade-off for a higher resolution, of course, being in terms of a slower throughput. As is known in the art, for all such line resolution settings, the relationship  $b = m_3 \times a$  applies but for different values of  $m_3$ .

A further feature of an ink jet printer operative in accordance with the teachings of the present invention is that the unprinted ink dot lines caused by a defective ink jet head can be at least partially compensated for by suitable manipulation of partially printed ink dot lines in their vicinity so as to restore picture quality as perceived by an observer even when an ink jet printer has one or more defective ink jet heads. The compensation of an unprinted ink dot line can be achieved by printing a printed ink dot line adjacent to an unprinted ink dot line with either additional ink dots or larger ink dots, if possible, so as to restore the original dot percentage. In color ink jet printers, the above described compensation technique is applied for each primary color separately.

The detection of a defective ink jet head can be achieved by an operator during, say, a routine start-of-day work procedure. Alternatively, it can be achieved automatically by means of a dedicated ink jet head test module including image processing and pattern recognition capabilities for processing the image of a printed image as provided by a camera directed theretoward.

Also in line with conventional practice, an ink jet printer operative in accordance with the teachings of the present invention preferably prints an image as a matrix of cells, each cell in turn being printed as a matrix of pixels. As known in the art, a separation gap "c" between adjacent cells along the direction in which the print head is intermittently displaced fulfills the following two relationships:  $c = m_4 \times a$  and  $b = m_5 \times c$  where  $m_4$  and  $m_5$  are natural numbers greater than zero. The spacing between consecutive ink dot lines of a particular ink jet head preferably greater than the separation gap "c" such that a particular ink jet head prints a maximum of one ink dot line in any one cell. In this case, the compensation of an unprinted ink dot line is preferably performed at the cell level in the sense that ink dot lines within a cell containing an unprinted ink dot line are printed with either additional ink dots or larger ink dots, if possible, so as to restore the original dot percentage. In the case that an unprinted ink dot line occurs at the edge of a cell, its dot percentage may be restored by modifying the adjacent printed ink dot line in its neighboring cell.

Ink jet printers in accordance with the teachings of the present invention can either be of the rotatable drum type or the flat bed type. In addition, they can be of the "continuous" ink jet printer type in which each ink jet head provides a continuous flow of ink drops of which some impinge on a substrate at desired printing locations whilst others are disposed of in a manner determined by the appearance of an image to be printed or the "impulse" or "drop-on-demand" ink jet printer type in which each ink jet head is independently actuated to expel ink drops in a manner determined by the appearance of an image to be printed.

## BRIEF DESCRIPTION OF THE DRAWINGS

For a better understanding of the present invention and to show how the same can be carried out in practice, reference will now be made, by way of a non-limiting example only, to the accompanying drawings in  
5 which:

**Fig. 1** illustrates an ellipse shaped image printed by a conventional ink jet printer having a defective ink jet head in the form of a blocked nozzle;

**Fig. 2** is a schematic view of a rotatable drum type ink jet printer constructed and operative in accordance with the teachings of the present  
10 invention;

**Fig. 3** is a front view of the print head of the ink jet printer of Figure 2 including four arrays of ink jet heads for four color process printing;

**Fig. 4** is a flow chart illustrating the method of operation for the ink jet printer of Figure 2;

**Fig. 5** illustrates the same ellipse shaped image printed by the ink jet printer of Figure 2 having a defective ink jet head in the form of a blocked nozzle;

**Figs. 6A-6C** illustrate the operation of the ink jet printer of Figure 2 for correcting the image of Figure 5; and

**Fig. 7** is a schematic view of a flat bed type ink jet printer constructed and operative in accordance with the teachings of the present  
25 invention.

## DETAILED DESCRIPTION OF THE DRAWINGS

Figure 2 shows an ink jet printer, generally designated 1, of the "drop-on-demand" type including a foraminous drum 2 bearing a removable substrate 3 preferably secured thereto by application of a vacuum to its  
30 underside. The drum 2 is rotatable about a shaft 4 under the control of a drum controller 5 constituting part of an ink jet printer controller 6 for



controlling the operation of the ink jet printer 1. Each substrate 3 is loaded onto the drum 2 and unloaded therefrom in a conventional manner be it manual or automatic.

5 A print head carriage 8 is mounted parallel to the shaft 4 and is displaceable therealong under the control of a print head carriage control-  
ler 9. The print head carriage 8 includes a print head 10 which extends along the near entire length of the drum 2 corresponding to the maximum width of substrate 3 to be printed thereon. As shown in Figure 3, the print head 10 includes four ink jet head arrays 11, 12, 13 and 15 for printing the  
10 four primary CMYK colors, namely, cyan, magenta, yellow and black. Each ink jet head array 11, 12, 13 and 15 is supplied with ink from a dedicated ink reservoir 11', 12', 13' and 15', respectively. The ink jet heads of the different arrays are not in registration with one another so as to ensure that they do not superimpose differently colored ink dot lines which would tend  
15 to mix, thereby lowering print quality.

Individual ink jet heads are actuated by an ink jet head driver 16 driven by a pixel pattern generator 17 which determines which pixels of a particular cell are to be filled by dots and the dot area of each of the selected dots in accordance with the dot percentage values of each color in  
20 that cell. The pixel pattern generator 17 includes a library of patterns for generating different dot percentages. In some cases, the library only contains a single pattern to achieve a particular dot percentage, for example, 0% dot percentage or 100% dot percentage. However, in practice, each cell is represented by a m x n pixel matrix, say, 6 x 6, such that there are a large  
25 number of possible patterns to achieve a particular dot percentage of, say, 40% dot percentage. For example, in a simplified case, there are four patterns which achieve a 25% dot percentage in a 2 by 2 cell matrix, namely, a dot in one corner of the cell matrix. Input to the pixel pattern generator 17 is provided from an external data source 18, for example,  
30 removable media i.e. an optical disk, or a desk-top publishing (DTP) system.

The operation of the ink jet heads of the print head 10 is monitored by an ink jet head test module 19 including image processing and pattern recognition capabilities for processing the image of a printed image as provided by on-line or off-line image acquisition apparatus, say, a camera 20, directed theretoward. In the case that one or more ink jet heads are found to be defective, typically, due to a blocked nozzle, the ink jet head test module 19 updates the pixel pattern generator 17 accordingly such that certain patterns which would require the actuation of defective ink jet heads are temporarily degenerated.

10 The principles of operation of the ink jet printer 1 are now described with reference to Figure 4. First, an operator downloads a file containing a pixelized image to be printed from a suitable source, for example, an optical disk. The operator then selects the desired line resolution at which the image is to be printed from the available range of line resolutions of the ink jet printer 1. Finally, the operator selects the  
15 desired spacing between consecutive ink dot lines of an ink jet head from the available range of spacings which, in turn, dictates the length of the step "y" through which the print head carriage 8 is displaced between consecutive rotations of the drum 2.

20 Based on his selections, the ink jet printer controller 6 determines the number of steps n through which the print head carriage 8 is required to be displaced so as to print an image of a predetermined width at the predetermined line resolution. Thereafter, the pixel pattern generator 17 selects a pattern of dots for each color of each cell according to its dot  
25 percentage from its library. The pixel pattern generator 17 provides the patterns to the ink jet head driver 16 which actuates the required ink jet heads in accordance with the appearance of the image to be printed during successive rotations of the drum 2 whilst advancing the print head carriage 8 through the step y between consecutive drum rotations.

30 An example of the operation of the ink jet printer 1 is shown in Figure 5 for printing the same ellipse shaped image as shown in Figure 1 during the same three drum rotations. As before, the ink jet lines printed

during each drum rotation are designated by the reference numbers 1, 2 and 3 for the first, second and third drum rotations, respectively. The print head 10 includes 7 ink jet heads labelled P, Q, R, S, T, U and V of which the ink jet heads P and Q are located in initially inoperative printing positions and ink jet heads R, S, T, U and V are located in initially operative printing positions in the initial home position of the print head carriage 8.

Thus, in this case, for a step "y" equivalent to the separation gap between four ink dot lines, printing of the ellipse shaped image is achieved by actuating the ink jet heads R, S, T, U and V in the initial home position of the print head carriage 8 during the first drum rotation, actuating the ink jet heads Q, R, S, T and U during the second drum rotation and actuating the ink jet heads P, Q, R, S and T during the third and final drum rotation. It can therefore be readily seen that whilst the ink jet heads P and Q are displaced from inoperative printing positions to operative printing positions during the advancement of the print head carriage 8, the ink jet heads U and V are displaced from operative printing positions to inoperative printing positions.

In the case that the ink jet head S is defective with a blocked nozzle, it will be readily noticed that the unprinted ink dot lines shown dashed and labelled S1, S2 and S3 caused thereby are spaced apart and therefore less conspicuous to an observer than in the case that they were adjacent to one another as hitherto occurred as described in the Background of the Invention as can be best appreciated by comparing the ellipse shaped image shown in Figure 5 to its counterpart in Figure 1.

The image quality of the ellipse shaped image shown in Figure 5 can be further improved by the ink jet head test module 19 as now explained. For example, assuming that all the ink jet heads P, Q, R and S are operative, Figure 6A shows a 4 by 4 pixel cell having, say, a 50% dot percentage value achieved by each of the ink dot lines printed by their respective ink jet heads containing two ink dots as determined by the pixel pattern generator 17. However, as evidenced in Figure 6B, the same cell

would only have a slightly less than, say, 30% dot percentage value in the case that the ink jet head S is inoperative. In such an event, the ink jet head test module 19 would update the pixel pattern generator 17 as to the status of the ink jet head S such that the pixel pattern generator 17 can instruct the ink jet head driver 16 to actuate the operative ink jet heads P, R and Q so as to print the cell with the desired 50% dot percentage value, for example, as shown in Figure 6C.

Figure 7 shows a flat bed type ink jet printer 23 having a substrate bearing flat bed 24 which performs a reciprocating motion in a first direction and a print head carriage 25 carrying a print head 26 with ink jet heads for printing parallel ink dot lines on a substrate 27 during a forward stroke of the flat bed 24. Thus, in this case, printing of an image is achieved by repeatedly returning the flat bed 24 to its home position by a return stroke, advancing the print head carriage 25 in a traverse direction relative to the flat bed 24 by a step "y" as described hereinabove and actuating the ink jet heads at each new position whilst displacing the flat bed 24 through a forward stroke so as to build up the image over a number of forward strokes of the flat bed 24. For the economy of time, it will be readily appreciated that the return stroke of the flat bed 24 and the step advancement of the print head carriage 25 can be performed simultaneously.

While the invention has been described with respect to a limited number of embodiments, it will be appreciated that many variations, modifications and other applications of the invention can be made by those ordinarily skilled in the art.

**CLAIMS:**

1. A method of operation for an ink jet printer having a print head with a plurality of spaced apart ink jet heads, the ink jet printer printing an image on a substrate at a predetermined line resolution, thereby defining an inter ink dot line separation gap between adjacent ink dot lines on the image, the method comprising the steps of:
- 5
- (a) positioning the print head relative to the substrate such that at least one ink jet head lies in an operative printing position over the substrate;
- 10
- (b) actuating at least one ink jet head overlying the substrate during displacement of the print head relative to the substrate in a first direction so as to print a corresponding number of ink dot lines on the substrate in a manner determined by the appearance of the image to be printed;
- 15
- (c) displacing the print head relative to the substrate in a second direction substantially transverse to the first direction through a step greater than the inter ink dot line separation gap; and
- 20
- (d) repeating steps (b) and (c) so as to print the entire image on the substrate.
2. The method according to Claim 1 wherein an image is made up of a matrix of cells and the print head is displaced relative to the substrate in the second direction through a step greater than the separation gap between adjacent cells.
- 25
3. The method according to either Claim 1 or 2 wherein the print head is displaced relative to the substrate in the second direction through a step greater than the inter ink jet head separation gap.
- 30

4. The method according to any one of Claims 1-3 further comprising the steps of:

(e) detecting an inoperative ink jet head;

5 (f) determining the at least one unprinted ink dot lines which should otherwise have been printed by the inoperative ink jet head; and

(g) compensating for the at least one unprinted ink dot line through manipulation of at least one ink dot line in the vicinity thereof.

10

5. The method according to Claim 4 wherein step (e) is by monitoring the ink dot lines printed on the substrate.

15 6. The method according to any one of Claims 1-5 wherein the ink jet printer is operative in a drop-on-demand mode of operation.

7. The method according to any one of Claims 1-5 wherein the ink jet printer is operative in a continuous mode of operation.

8. A rotatable drum type ink jet printer operative in accordance with any one of Claims 1-7.

9. A flat bed type ink jet printer operative in accordance with any one of Claims 1-7.

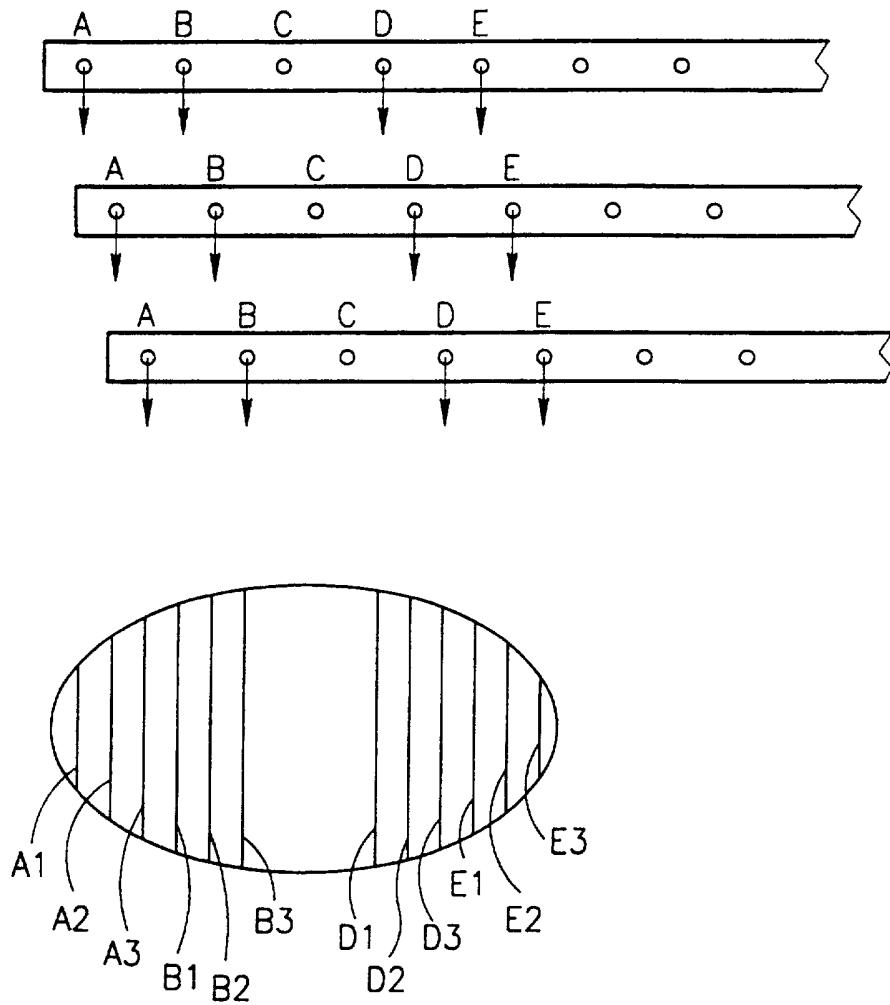

FIG. 1  
PRIOR ART

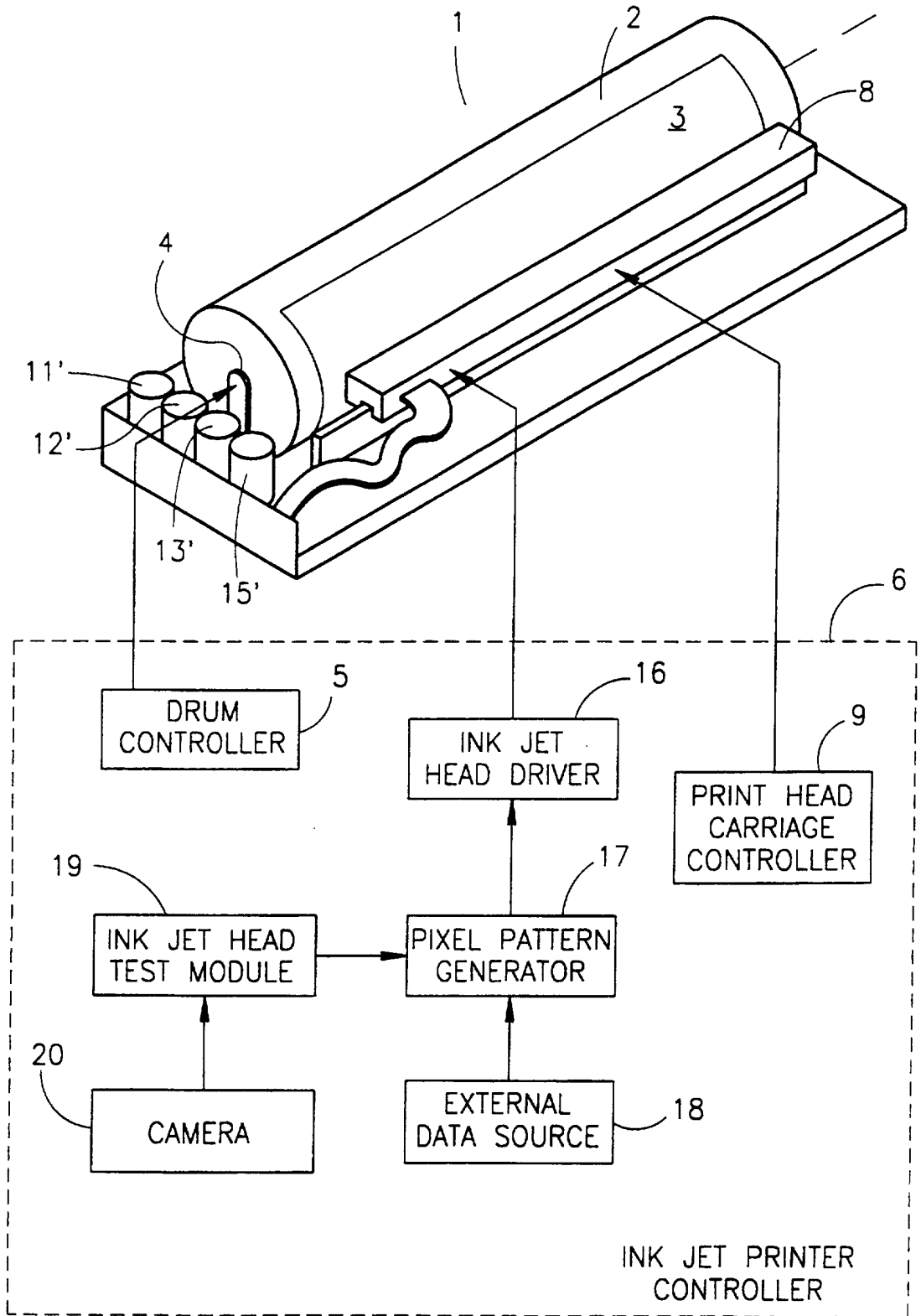

FIG.2



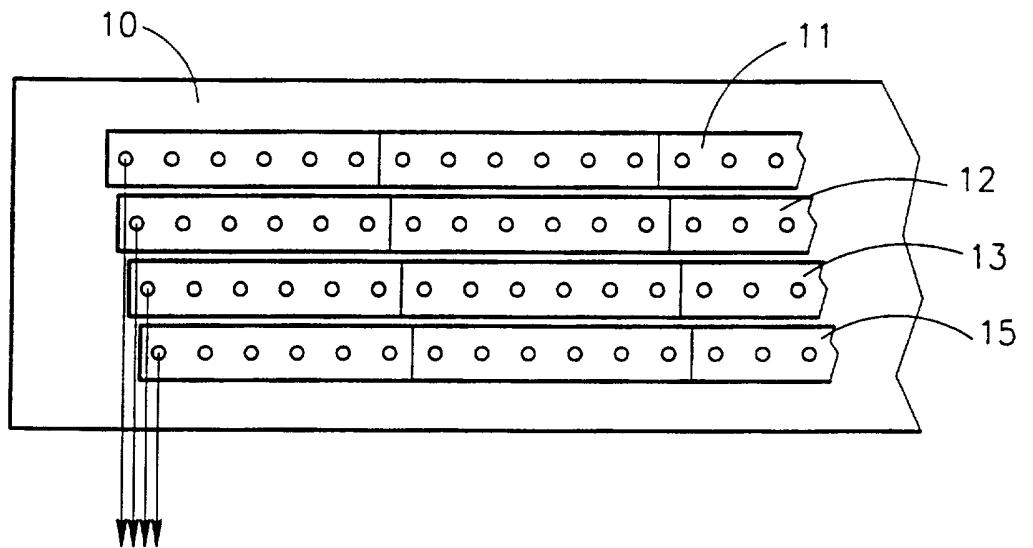
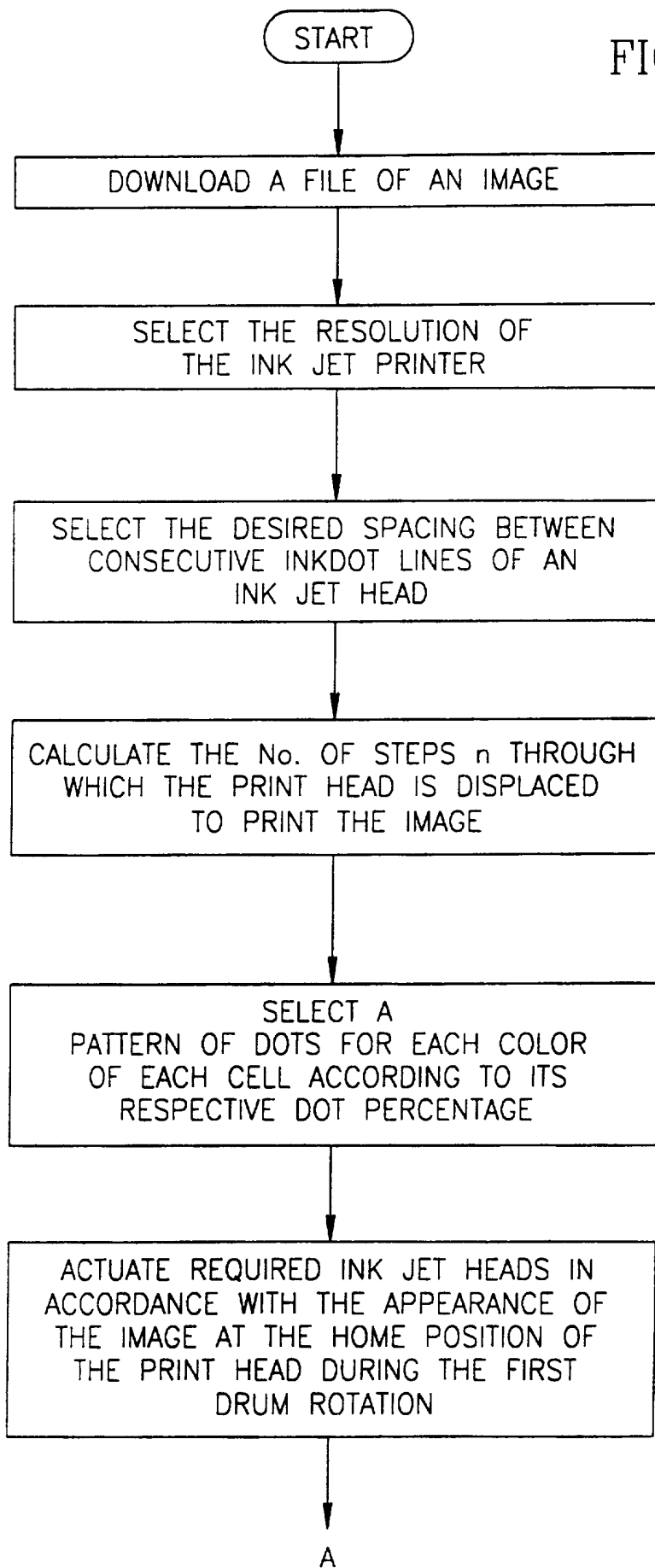

FIG.3

4/8

FIG.4A



5/8

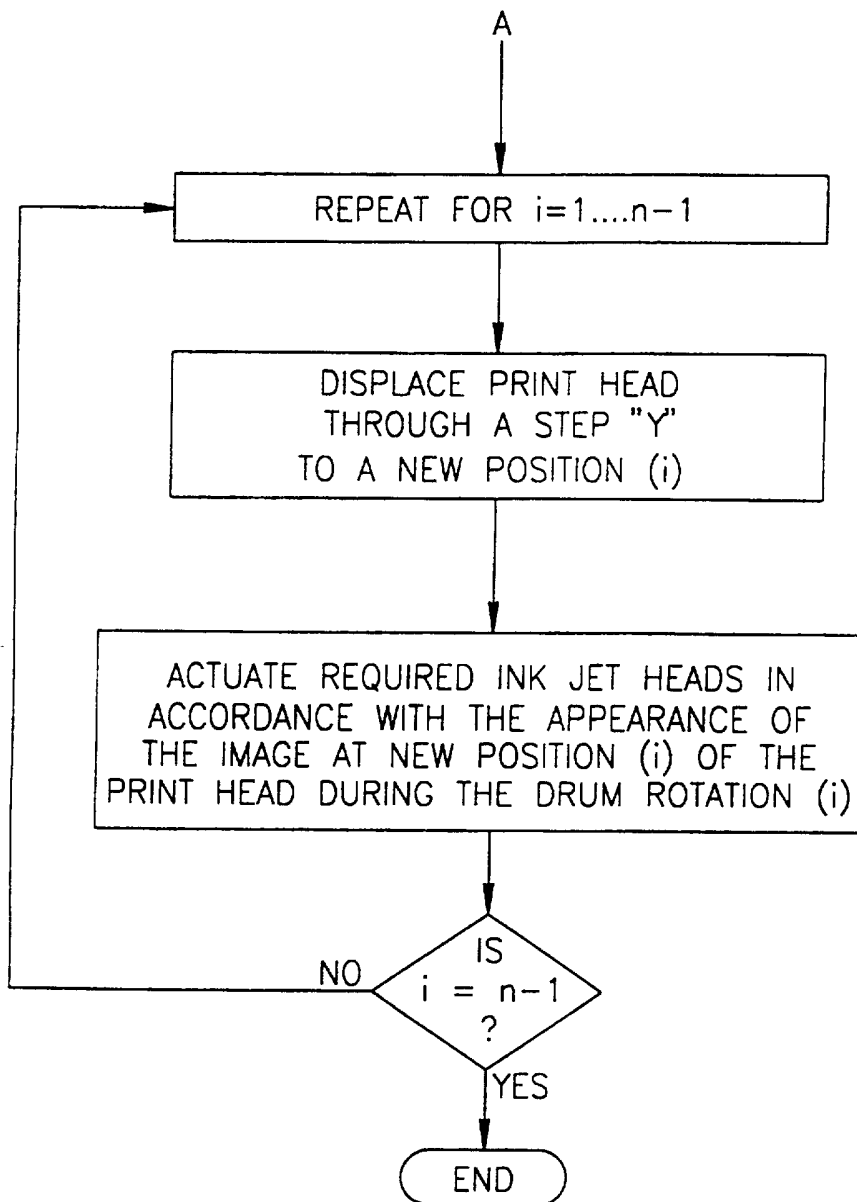

FIG.4B

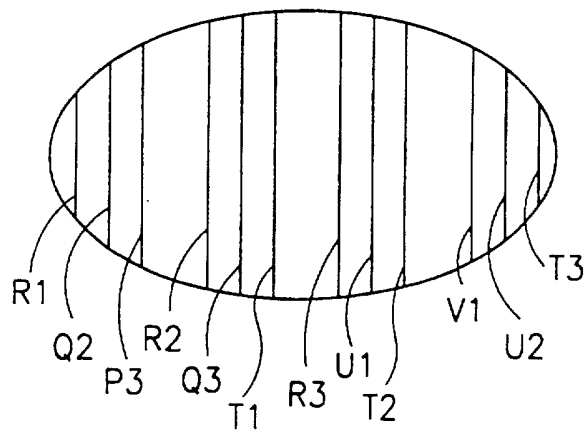
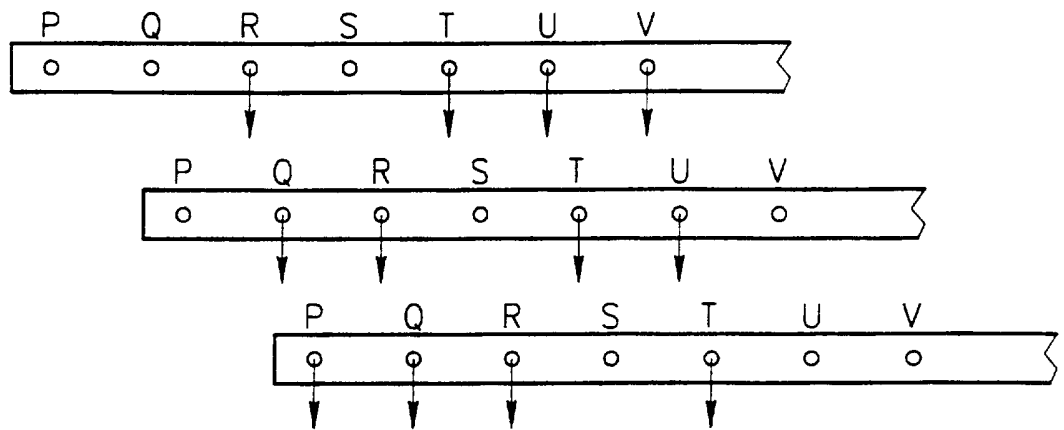

FIG.5

7/8

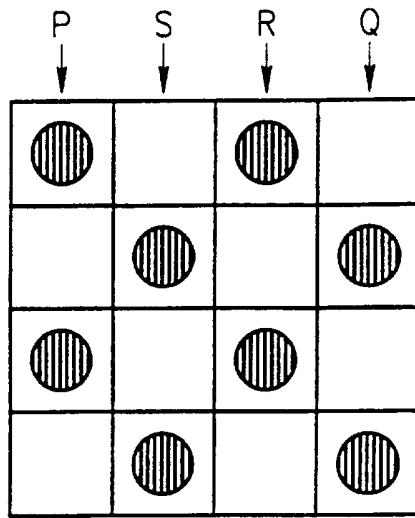

FIG.6A

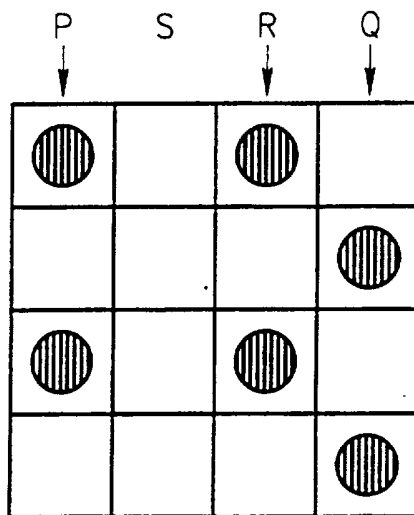

FIG.6B

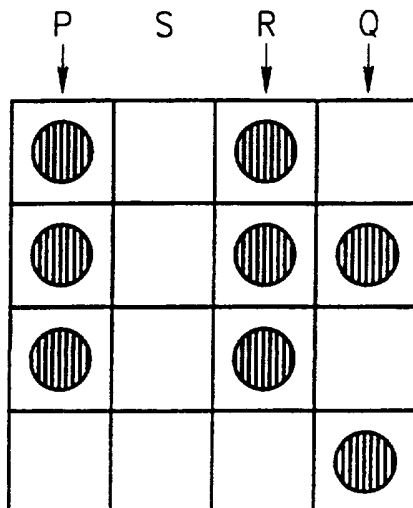
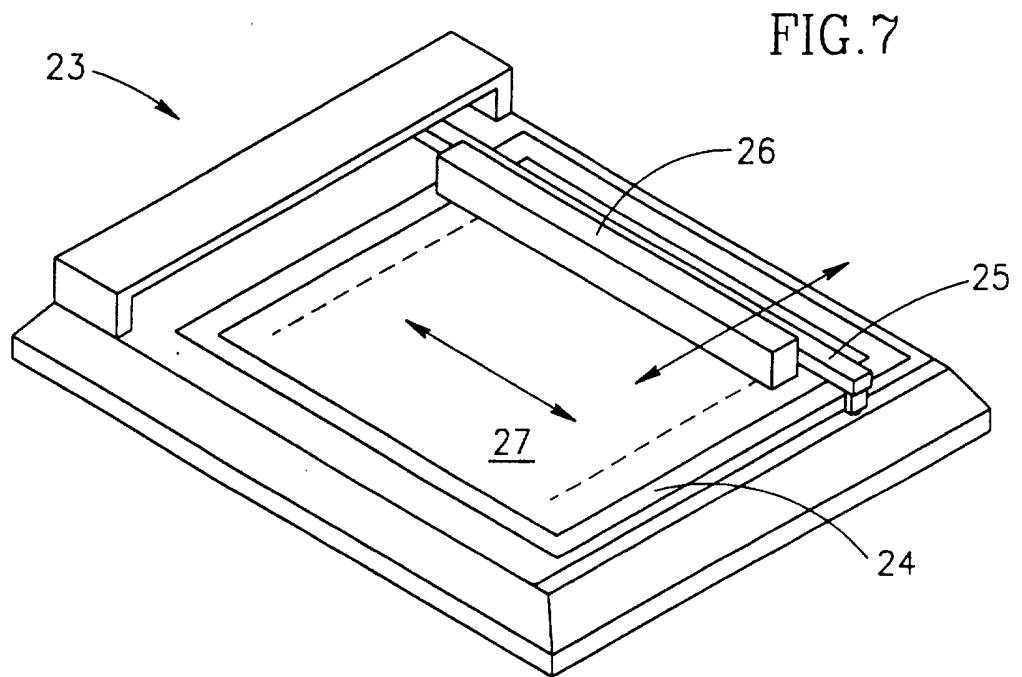

FIG.6C



# INTERNATIONAL SEARCH REPORT

International Application No  
PCT/IL 97/00071

**A. CLASSIFICATION OF SUBJECT MATTER**  
IPC 6 B41J2/505 B41J2/515 G06K15/10

According to International Patent Classification (IPC) or to both national classification and IPC

**B. FIELDS SEARCHED**

Minimum documentation searched (classification system followed by classification symbols)  
IPC 6 B41J G06K

Documentation searched other than minimum documentation to the extent that such documents are included in the fields searched

Electronic data base consulted during the international search (name of data base and, where practical, search terms used)

**C. DOCUMENTS CONSIDERED TO BE RELEVANT**

Category *	Citation of document, with indication, where appropriate, of the relevant passages	Relevant to claim No.
X	EP 0 497 614 A (TEKTRONIX INC.) 5 August 1992 see column 3, line 48 - column 5, line 42 ---	1,6-9
X	EP 0 568 283 A (CANON KK.) 3 November 1993 see column 5 - column 8 ---	1,6,7
X	EP 0 422 924 A (TEKTRONIX INC.) 17 April 1991 see figures 4,5 ---	1,3,6-9
X	EP 0 564 252 A (CANON KK.) 6 October 1993 see column 28, line 16 - column 31, line 11 ---	1,2,6,9
A	EP 0 567 288 A (CANON KK.) 27 October 1993 see column 15, line 35 - column 16, line 45; figure 10 ---	1
	-/--	

Further documents are listed in the continuation of box C.       Patent family members are listed in annex.

\* Special categories of cited documents :

<p>*A* document defining the general state of the art which is not considered to be of particular relevance</p> <p>*E* earlier document but published on or after the international filing date</p> <p>*L* document which may throw doubts on priority claim(s) or which is cited to establish the publication date of another citation or other special reason (as specified)</p> <p>*O* document referring to an oral disclosure, use, exhibition or other means</p> <p>*P* document published prior to the international filing date but later than the priority date claimed</p>	<p>*T* later document published after the international filing date or priority date and not in conflict with the application but cited to understand the principle or theory underlying the invention</p> <p>*X* document of particular relevance; the claimed invention cannot be considered novel or cannot be considered to involve an inventive step when the document is taken alone</p> <p>*Y* document of particular relevance; the claimed invention cannot be considered to involve an inventive step when the document is combined with one or more other such documents, such combination being obvious to a person skilled in the art.</p> <p>*&amp;* document member of the same patent family</p>
--	--

Date of the actual completion of the international search  <b>16 June 1997</b>	Date of mailing of the international search report  <b>02. 07. 97</b>
--	---

Name and mailing address of the ISA European Patent Office, P.B. 5818 Patentlaan 2 NL - 2280 HV Rijswijk Tel. (+ 31-70) 340-2040, Tx. 31 651 epo nl, Fax: (+ 31-70) 340-3016	Authorized officer  <b>Van Oorschot, J</b>
--	--

# INTERNATIONAL SEARCH REPORT

International Application No  
PCT/IL 97/00071

C.(Continuation) DOCUMENTS CONSIDERED TO BE RELEVANT		
Category *	Citation of document, with indication, where appropriate, of the relevant passages	Relevant to claim No.
A	EP 0 023 433 A (XEROX CORP.) 4 February 1981	
A	--- EP 0 677 390 A (OLIVETTI-CANON INDUSTRIALE S.P.A.) 18 October 1995	
A	--- PATENT ABSTRACTS OF JAPAN vol. 005, no. 158 (M-091), 12 October 1981 & JP 56 084970 A (CANON INC), 10 July 1981, see abstract -----	

1



# INTERNATIONAL SEARCH REPORT

Information on patent family members

International Application No

PCT/IL 97/00071

Patent document cited in search report	Publication date	Patent family member(s)	Publication date
EP 497614 A	05-08-92	DE 69203101 D	03-08-95
		DE 69203101 T	18-01-96
		JP 5069598 A	23-03-93
		US 5300957 A	05-04-94
-----			
EP 568283 A	03-11-93	JP 6079956 A	22-03-94
		CN 1089551 A	20-07-94
-----			
EP 422924 A	17-04-91	US 5117374 A	26-05-92
		US 4978971 A	18-12-90
		DE 69024589 D	15-02-96
		DE 69024589 T	18-07-96
		DE 69028470 D	17-10-96
		DE 69028470 T	06-02-97
		DE 69029359 D	23-01-97
		EP 0422925 A	17-04-91
		EP 0422926 A	17-04-91
		JP 3188321 A	16-08-91
		JP 3246041 A	01-11-91
		JP 3246042 A	01-11-91
		US 5155499 A	13-10-92
-----			
EP 564252 A	06-10-93	JP 5278231 A	26-10-93
		JP 5278232 A	26-10-93
		JP 5318770 A	03-12-93
		JP 6022106 A	28-01-94
		JP 6040046 A	15-02-94
		JP 6040038 A	15-02-94
		US 5633663 A	27-05-97
-----			
EP 567288 A	27-10-93	JP 5293975 A	09-11-93
		AU 3022595 A	26-10-95
		AU 3702793 A	18-11-93
		CA 2094365 A	22-10-93
		CN 1087581 A	08-06-94
-----			
EP 023433 A	04-02-81	JP 56021287 A	27-02-81
-----			
EP 677390 A	18-10-95	IT T0940286 A	16-10-95
		JP 7276794 A	24-10-95