



US00D710274S

(12) **United States Design Patent**
Canni et al.

(10) **Patent No.:** **US D710,274 S**

(45) **Date of Patent:** **** Aug. 5, 2014**

(54) **WINDSHIELD CONFIGURATION FOR REVERSE TRIKE**

Primary Examiner — Katrina A Betton
(74) *Attorney, Agent, or Firm* — Cooley LLP

(71) Applicant: **Tanom Motors, LLC**, Culpeper, VA (US)

(72) Inventors: **Adam Canni**, Fleming Island, FL (US);
Clyde T. Sliger, Culpeper, VA (US);
Merrill C. Hall, Culpeper, VA (US)

(57) **CLAIM**

The ornamental design for a windshield configuration for reverse trike, as shown and described.

(73) Assignee: **Tanom Motors, LLC**, Culpeper, VA (US)

DESCRIPTION

(**) Term: **14 Years**

(21) Appl. No.: **29/444,776**

(22) Filed: **Feb. 4, 2013**

Related U.S. Application Data

(62) Division of application No. 29/405,222, filed on Oct. 31, 2011, now Pat. No. Des. 678,124.

(51) **LOC (10) Cl.** **12-08**

(52) **U.S. Cl.**
USPC **D12/182**

(58) **Field of Classification Search**
USPC D12/182-183, 317; 219/203; 296/84.1,
296/77.1, 96.12, 96.19, 97.1, 95.1;
160/370.21, 370.22

See application file for complete search history.

FIG. 1 is a front left perspective view of the windshield configuration for reverse trike;
FIG. 2 is a rear left perspective view of the windshield configuration for reverse trike illustrated in FIG. 1;
FIG. 3 is a left side view of the windshield configuration for reverse trike illustrated in FIG. 1, the right side view being a mirror image of the left side view;
FIG. 4 is a front end view of the windshield configuration for reverse trike illustrated in FIG. 1;
FIG. 5 is a rear view of the windshield configuration for reverse trike illustrated in FIG. 1;
FIG. 6 is a top view of the windshield configuration for reverse trike illustrated in FIG. 1;
FIG. 7 is an enlarged front left perspective view of the windshield configuration for reverse trike, the enlarged region being identified by the region Z1 in FIG. 1;
FIG. 8 is an enlarged front left perspective view of the windshield configuration for reverse trike, the enlarged region being identified by the region Z4 in FIG. 4; and,
FIG. 9 is an enlarged front left perspective view of the windshield configuration for reverse trike, the enlarged region being identified by the region Z6 in FIG. 6.
In the drawings, the dashed lines (- -) depict portions of the article that form no part of the claimed design. The chain lines (- - -) represent the bounds of the claimed design. The boundary illustrated by the chain lines does not exist in reality in the article embodying the design.

(56) **References Cited**

U.S. PATENT DOCUMENTS

D55,440 S 6/1920 Smith
1,989,995 A 2/1935 Martin
D94,847 S 3/1935 Martin

(Continued)

OTHER PUBLICATIONS

Noah Joseph, "Part Harley, Part Hot Rod, All Crazy," [retrieved from the Internet], Campagna V13R [retrieved on Oct. 12, 2012], Oct. 27, 2011.

(Continued)

1 Claim, 9 Drawing Sheets

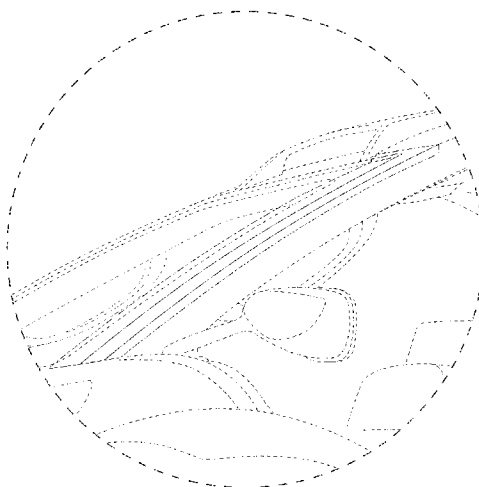

(56)

References Cited

U.S. PATENT DOCUMENTS

2,788,858 A 4/1957 Aasland et al.
 2,818,929 A 1/1958 Kucera
 3,419,098 A 12/1968 Mayers et al.
 3,610,358 A 10/1971 Korff
 D248,461 S * 7/1978 Edmonson D12/85
 D260,871 S * 9/1981 Cargile D12/85
 D262,871 S * 2/1982 Powers D12/85
 4,448,278 A 5/1984 Badsey
 4,453,763 A 6/1984 Richards
 D274,995 S * 8/1984 Richards et al. D12/85
 4,506,753 A 3/1985 Wood, Jr.
 D283,113 S * 3/1986 Stollery D12/85
 4,583,613 A 4/1986 Nakayama
 4,671,563 A * 6/1987 Shakespear 296/181.1
 5,236,060 A 8/1993 Huber
 5,431,243 A 7/1995 Richards
 5,806,622 A * 9/1998 Murphy 180/210
 D407,348 S * 3/1999 Riley D12/85
 5,960,901 A 10/1999 Hanagan
 6,015,022 A * 1/2000 Thuliez 180/210
 D424,979 S 5/2000 Hanagan et al.
 D427,548 S * 7/2000 Sacco et al. D12/85
 D449,018 S 10/2001 Musser
 D469,037 S 1/2003 Hanagan et al.
 D469,386 S 1/2003 Hanagan et al.
 6,523,634 B1 2/2003 Gagnon et al.
 6,651,764 B2 11/2003 Fournier et al.
 D485,788 S 1/2004 Guay et al.
 6,708,579 B2 3/2004 Punko
 6,948,581 B2 9/2005 Fecteau et al.
 D555,440 S * 11/2007 Murray D8/1

7,377,295 B2 5/2008 Byers et al.
 7,464,781 B2 12/2008 Guay et al.
 D584,188 S 1/2009 Jenkins et al.
 7,484,767 B2 2/2009 Tsuya
 D589,844 S 4/2009 Aubé et al.
 D592,547 S 5/2009 Riley
 D592,548 S 5/2009 Aubé et al.
 D593,908 S 6/2009 Longpre et al.
 7,543,672 B2 6/2009 Codere et al.
 7,571,787 B2 8/2009 Saiki
 7,591,337 B2 9/2009 Suhre et al.
 7,621,362 B2 11/2009 Ogawa et al.
 D613,203 S 4/2010 Geslin et al.
 D626,032 S 10/2010 Starr
 D633,821 S 3/2011 Hill et al.
 7,926,607 B2 4/2011 Seiter
 8,061,465 B2 11/2011 Martino
 D666,127 S 8/2012 Nam
 D678,124 S 3/2013 Canni et al.
 D682,158 S 5/2013 Canni et al.
 2007/0256882 A1 11/2007 Bedard et al.
 2011/0006498 A1 1/2011 Mercier
 2012/0241237 A1 9/2012 Holroyd et al.
 2012/0241239 A1 9/2012 Holroyd et al.
 2013/0105238 A1 5/2013 Hall et al.

OTHER PUBLICATIONS

“The street legal Pavement Predator,” T-Rex 14R, Campagna, 2011.
 “T-Rex: Three Wheeled Sports Car or Motorcycle,” [retrieved from the Internet] [retrieved on Sep. 18, 2012].
 Search and Examination Report for Australian Patent Application No. 12130/2012, mailed Sep. 18, 2012.

* cited by examiner

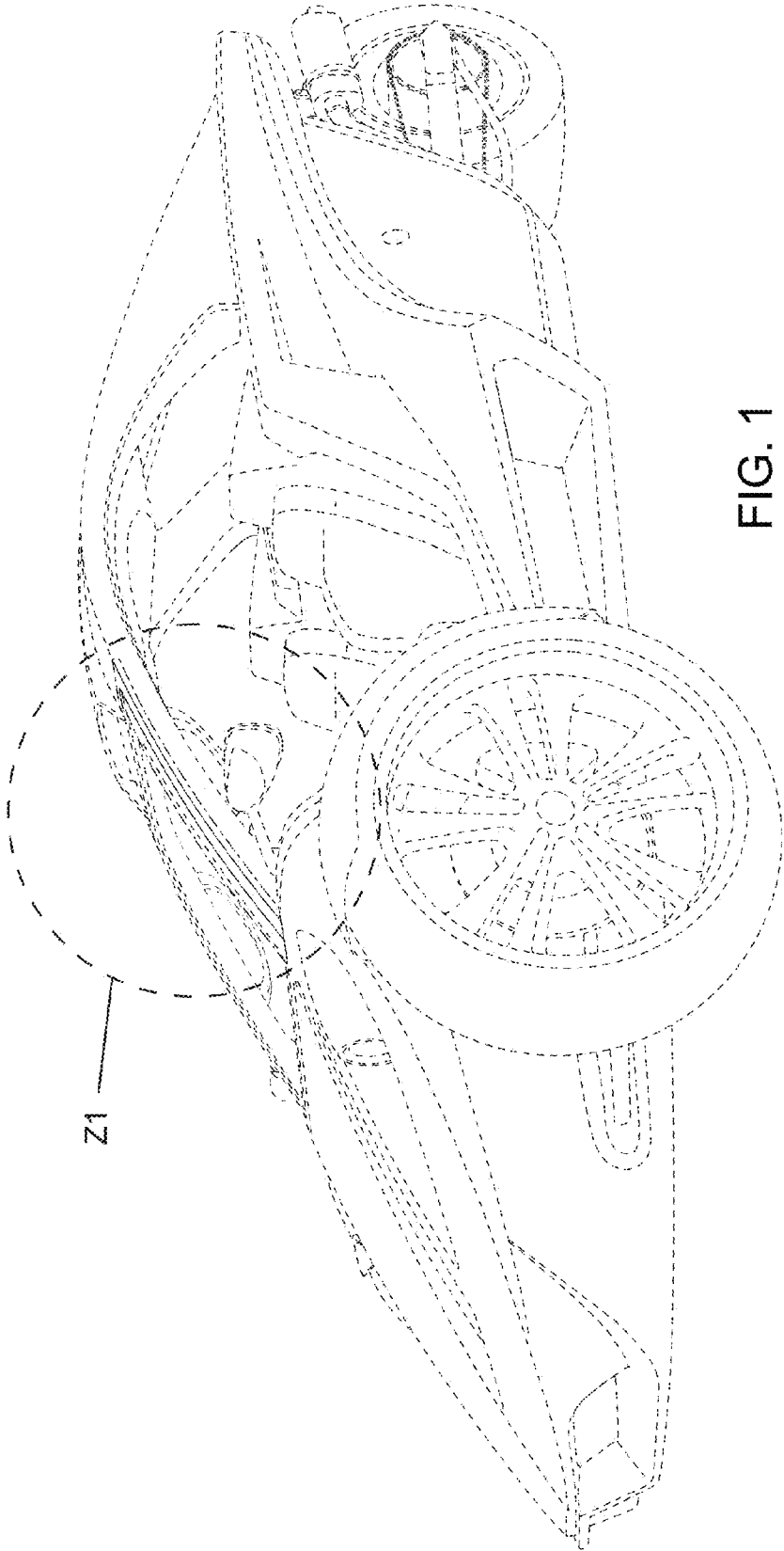

FIG. 1

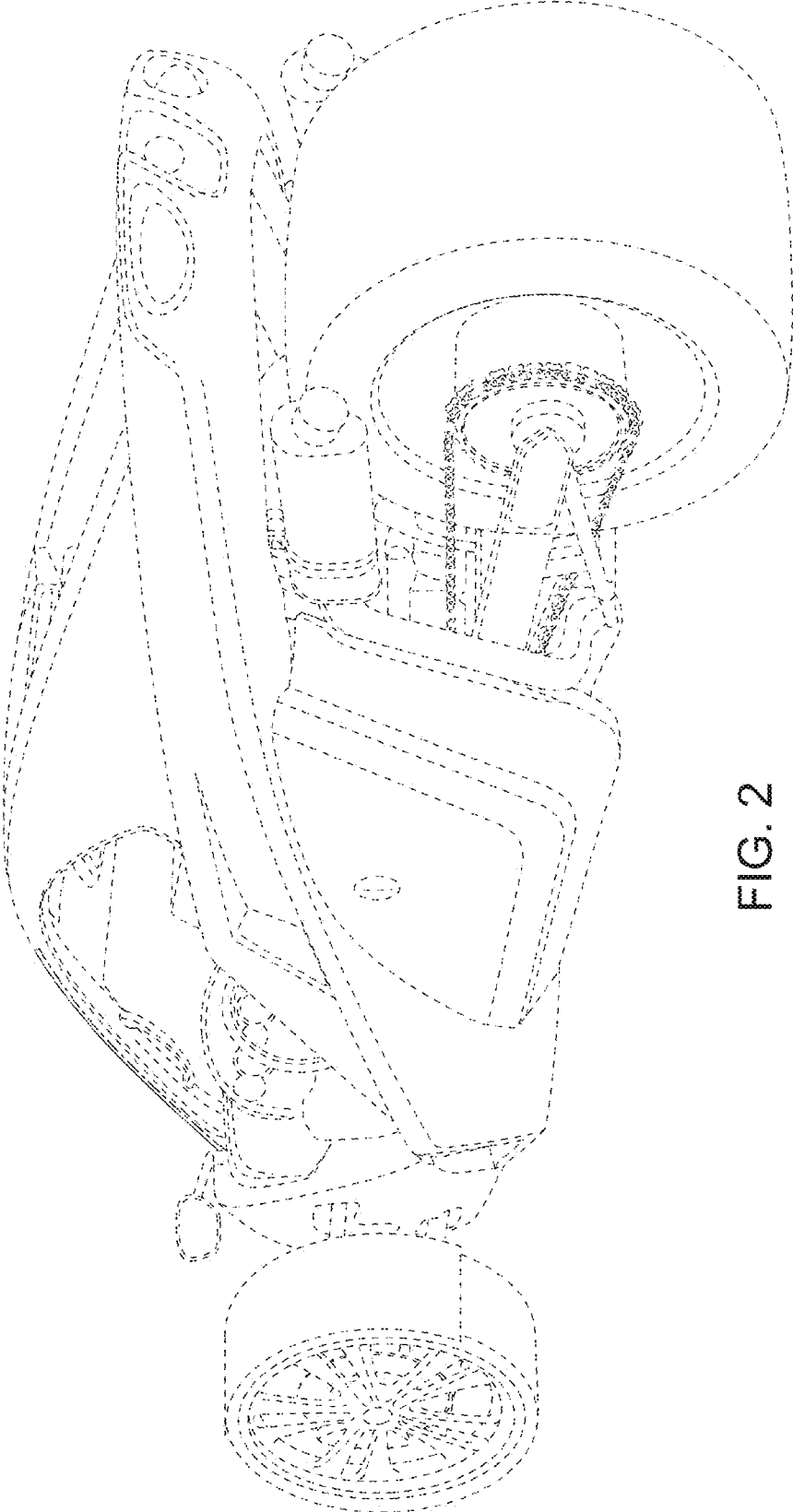

FIG. 2

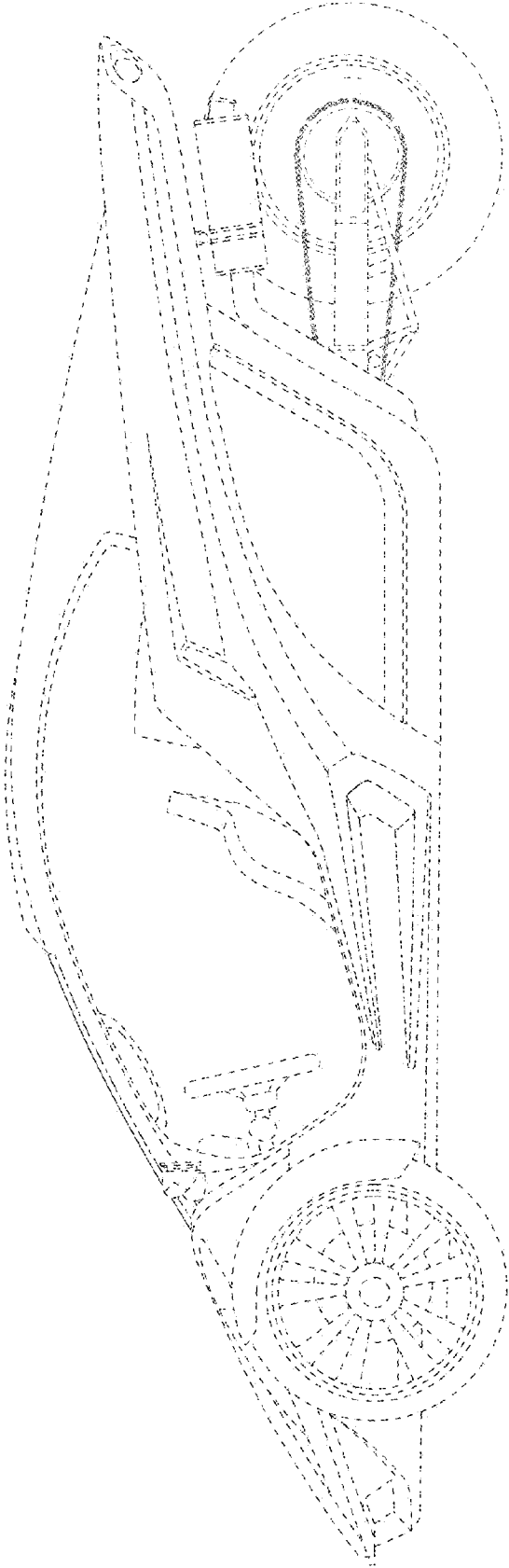

FIG. 3

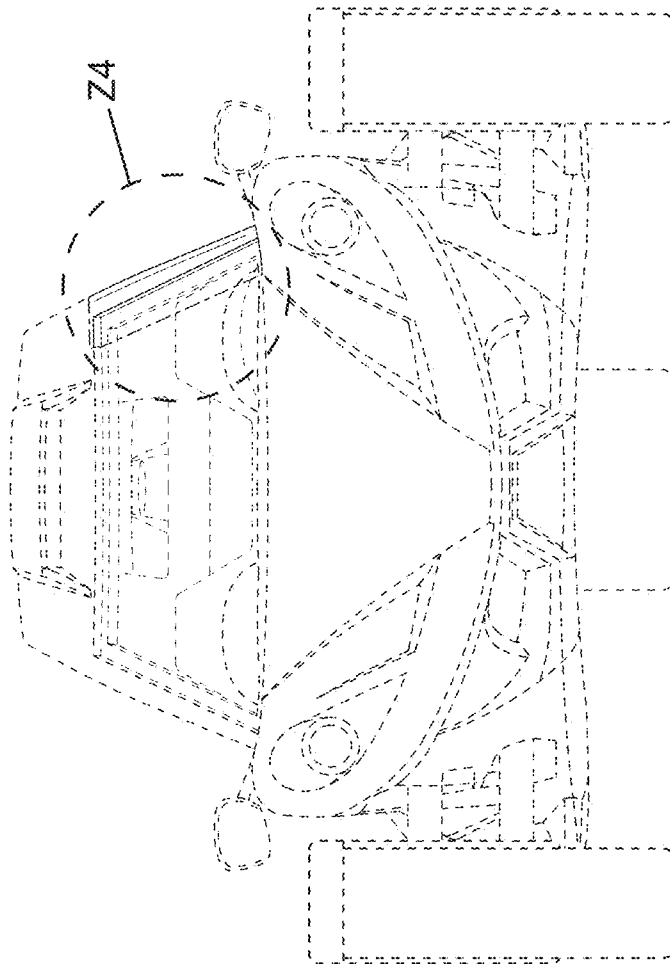

FIG. 4

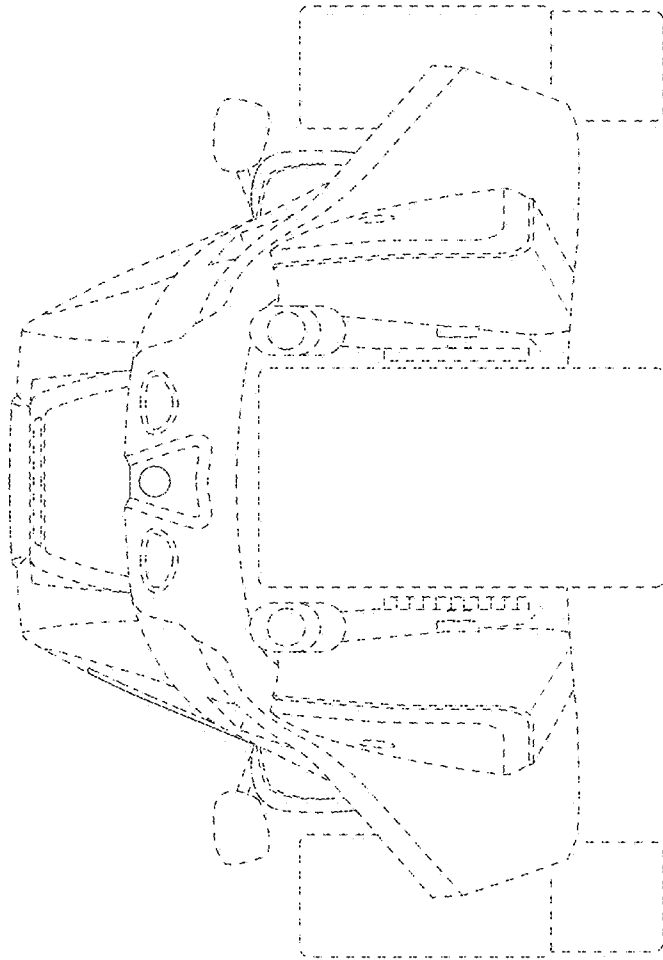

FIG. 5

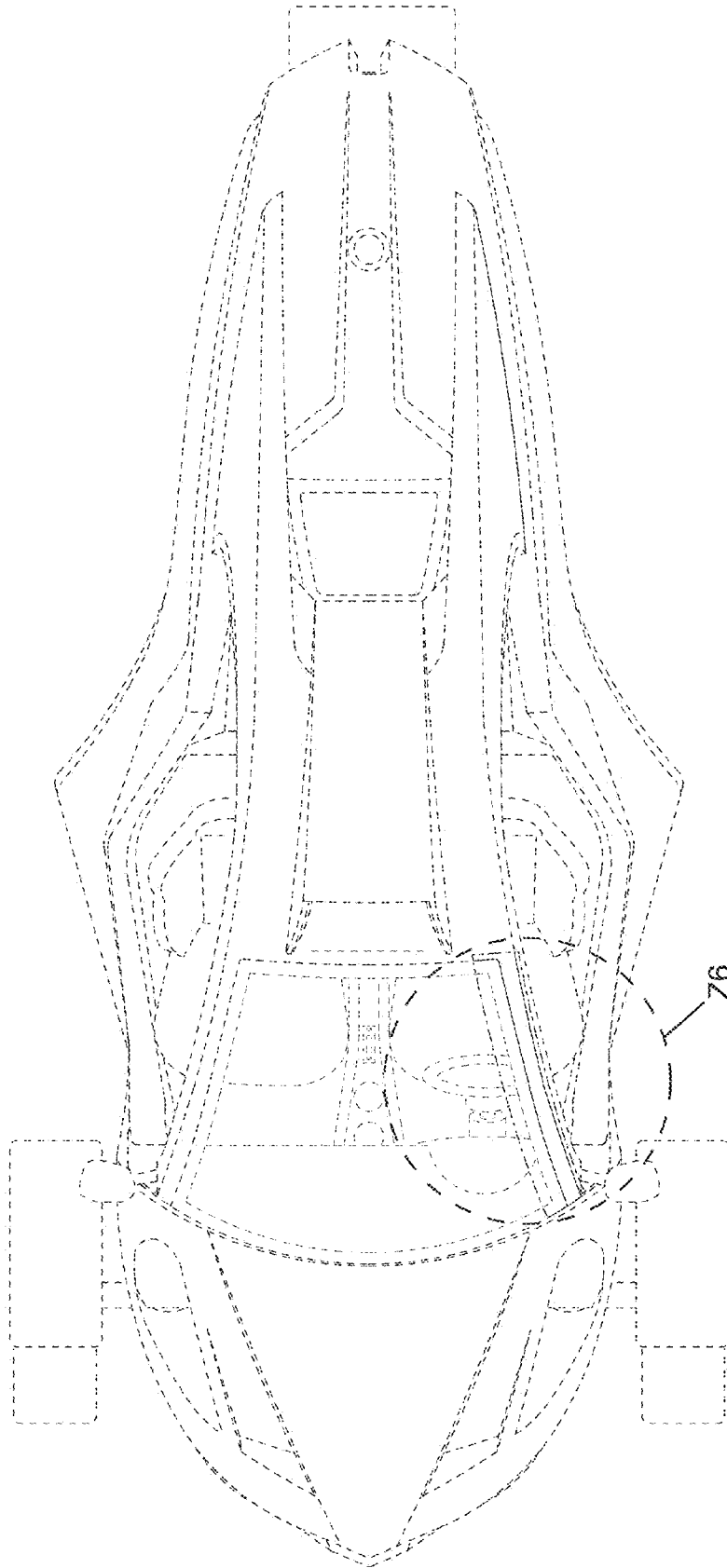

FIG. 6

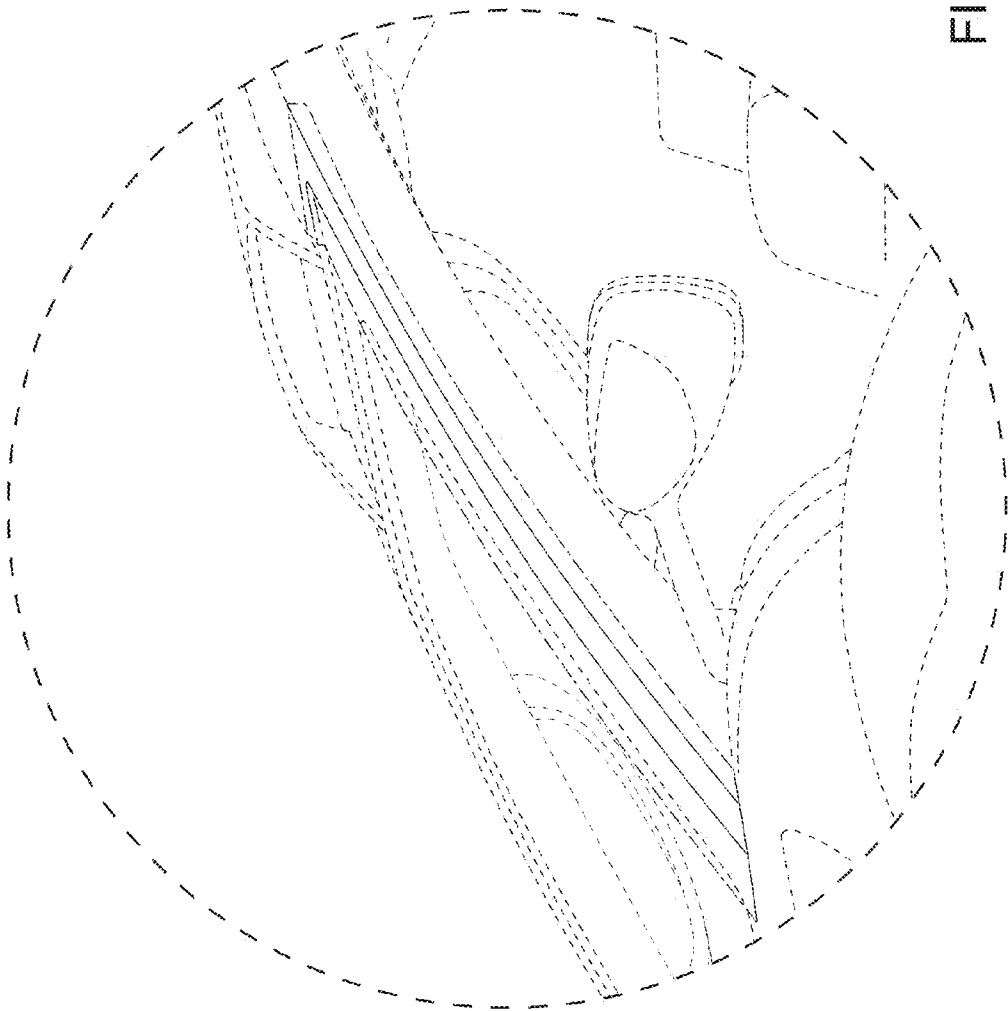

FIG. 7

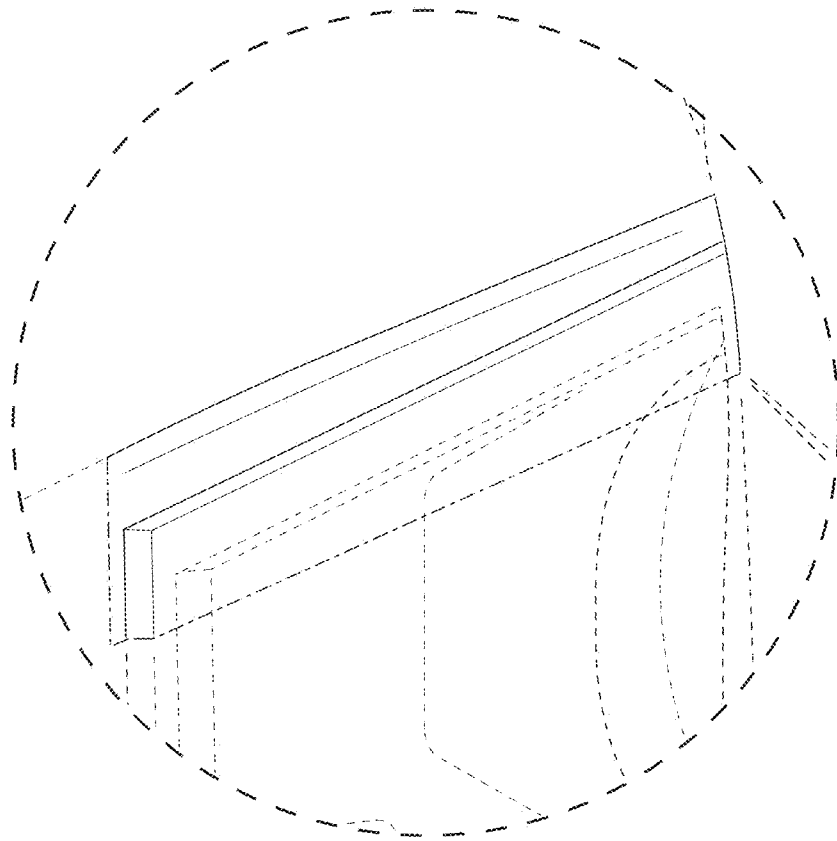

FIG. 8

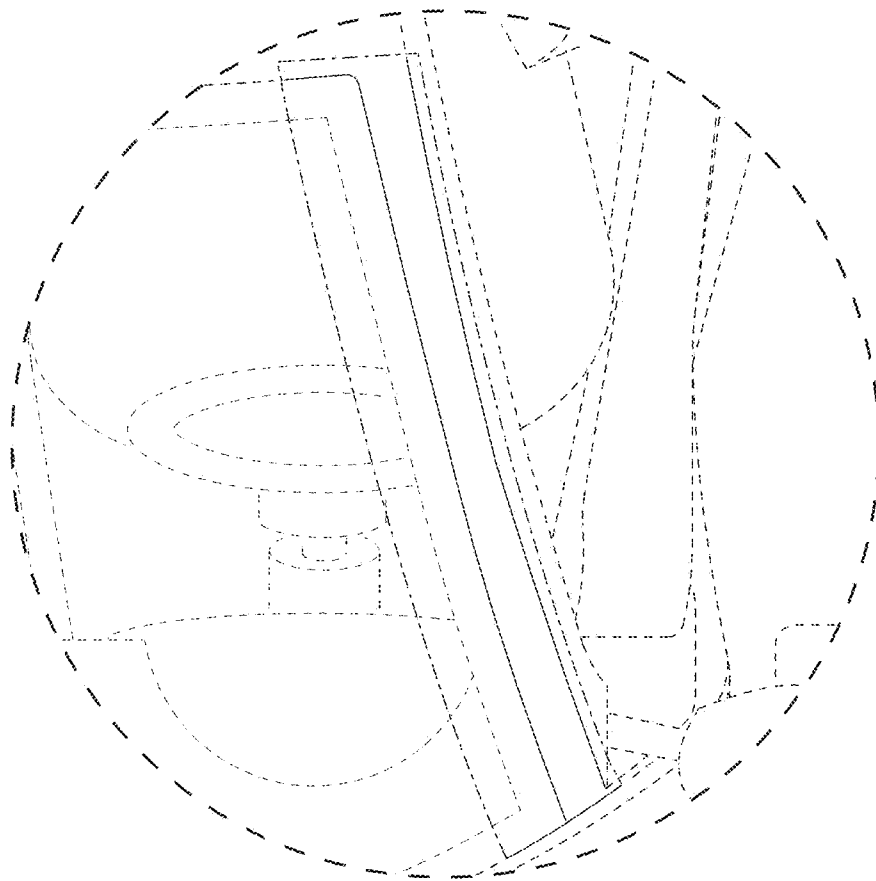

FIG. 9