



(11) **EP 2 563 693 B1**

(12) **EUROPEAN PATENT SPECIFICATION**

(45) Date of publication and mention of the grant of the patent:
23.12.2020 Bulletin 2020/52

(21) Application number: **11716256.0**

(22) Date of filing: **26.04.2011**

(51) Int Cl.:
B65F 1/14 (2006.01)

(86) International application number:
PCT/EP2011/056532

(87) International publication number:
WO 2011/134935 (03.11.2011 Gazette 2011/44)

(54) **REFUSE CONTAINER APPARATUS FOR AN UNDERGROUND REFUSE COLLECTING ARRANGEMENT**

MÜLLBEHÄLTER FÜR EINE UNTERIRDISCHE MÜLLSAMMELANORDNUNG

DISPOSITIF DE CONTENEUR À DÉCHETS POUR UN AGENCEMENT DE COLLECTE DES DÉCHETS SOUS-TERRAIN

(84) Designated Contracting States:
AL AT BE BG CH CY CZ DE DK EE ES FI FR GB GR HR HU IE IS IT LI LT LU LV MC MK MT NL NO PL PT RO RS SE SI SK SM TR
Designated Extension States:
BA

(30) Priority: **28.04.2010 DE 102010018567**

(43) Date of publication of application:
06.03.2013 Bulletin 2013/10

(73) Proprietor: **ESE World B.V.**
6199 AM Maastricht-Airport (NL)

(72) Inventor: **VERHESEN, P., H., M.**
NL-6063 CS Vlodrop (NL)

(74) Representative: **Müller, Thomas et al**
Patentanwalt
emescon
Balanstraße 57
81541 München (DE)

(56) References cited:
EP-A1- 1 167 241 EP-A1- 2 325 108
AU-A1- 2006 204 642 AU-B2- 2006 204 645
NL-C2- 1 005 958

EP 2 563 693 B1

Note: Within nine months of the publication of the mention of the grant of the European patent in the European Patent Bulletin, any person may give notice to the European Patent Office of opposition to that patent, in accordance with the Implementing Regulations. Notice of opposition shall not be deemed to have been filed until the opposition fee has been paid. (Art. 99(1) European Patent Convention).

Description

[0001] The present invention relates first of all to a refuse container apparatus for an underground refuse collecting arrangement according to the preamble of claim 1. Moreover, the invention also relates to an underground refuse collecting arrangement, which accommodates such a refuse container apparatus. Finally, the invention also relates to a construction set for an underground refuse collecting arrangement and a method of assembling an underground refuse collecting arrangement using such a construction set.

[0002] Underground refuse collecting arrangements *per se* have long been known. Such arrangements generally consist first of all of an exterior housing that is set into a corresponding pit in the ground. The exterior housing, which is made of concrete, for example, serves on the one hand to keep ground water out. On the other hand it also serves as a protection to keep soil out and maintain the contour of the arrangement as a whole.

[0003] Within the exterior housing is the actual refuse collecting container which has a lid element that closes off the refuse collecting container at the top, the lid element having a receiving opening for refuse. The refuse collecting container which is located inside the exterior housing, and hence below ground level, when the underground refuse collecting arrangement is in use in the intended manner, serves to actually receive the refuse.

[0004] To enable a refuse collecting container of this kind to be emptied, a handling device is provided by means of which the refuse collecting container can be removed from the exterior housing, for example, and taken for emptying. Also, the handling device is used for introducing the refuse collecting container into the exterior housing during the assembly of the underground refuse collecting arrangement.

[0005] While the refuse collecting container is located outside the exterior housing, a safety system is activated, in particular, which may comprise a safety platform, for example, by means of which the empty exterior housing is or remains closed off to prevent accidents.

[0006] During the assembly of the underground refuse collecting arrangement, once the exterior housing has been assembled, in a next step the safety system is installed, for example. Then the refuse collecting container is installed.

[0007] Refuse is thrown into the underground refuse collecting arrangement *per se* by means of a disposal housing for refuse which is provided or arranged above the receiving opening. The disposal housing is connected to the refuse collecting container. Assembly takes place, for example, after the refuse collecting container has been placed in the exterior housing for the first time.

[0008] The disposal housing may have a disposal chute, for example. In particular, the disposal housing also has a drop-in opening for refuse.

[0009] An underground refuse collecting arrangement of the kind described above is described for example in

DE 299 23 490 U1. Another type of underground collection system is described in AU 2006 204 645 B2, which discloses a refuse container apparatus according to the preamble of claim 1.

[0010] The particular advantage of underground refuse collecting arrangements of this kind is that large amounts of refuse can be accumulated without adversely affecting the appearance of the locality. The only part visible to the user is the disposal housing, which can be made visually attractive and discreet. The refuse collecting container itself is generally not visible as it is stored underground in normal use. The refuse collecting container only has to be removed from underground storage for emptying.

[0011] Alternatively, it is also possible to empty the refuse collecting container by suction using a suction apparatus.

[0012] However, underground refuse collecting arrangements of this kind have a number of drawbacks, particularly in their assembly.

[0013] Usually, the individual components of underground refuse collecting arrangements of this kind are first produced in different manufacturing processes, often by different manufacturers, and usually at different sites.

[0014] The individual components are then delivered to the assembly site by the different manufacturers. There, the individual components are gradually assembled to form the underground refuse collecting arrangement.

[0015] Coordinating the individual components at the assembly site, and coordinating the workforce to carry out the assembly, are costly and time-consuming processes. Moreover, this type of assembly not infrequently means that the installation site has to be closed off for lengthy periods, installation equipment such as cranes or the like have to be kept on standby over a long period and a large number of workers are needed to install the underground refuse collecting arrangement.

[0016] Starting from this the present invention sets out to provide solutions by means of which an underground refuse collecting arrangement can be manufactured and assembled at the installation site cheaply and in good time.

[0017] This aim is achieved according to the invention by the refuse container apparatus having the features according to independent claim 1, the underground refuse collecting arrangement having the features according to independent claim 5, the construction set for an underground refuse collecting arrangement having the features according to independent claim 8 and the method of installing an underground refuse collecting arrangement having the features according to independent claim 12. Other features and details of the invention will become apparent from the sub-claims, the description and the drawings. Features and details that are described in connection with the refuse container apparatus according to the invention naturally also apply in their entirety to the underground refuse collecting arrangement ac-

according to the invention, the construction set and the assembly process, and *vice versa*.

[0018] According to the first aspect of the invention, a refuse container apparatus for an underground refuse collecting arrangement is provided, which comprises the features of independent claim 1.

[0019] In this way it is possible to position the drop-in housing inside the refuse collecting container before assembly, for example during transporting. During assembly, the drop-in housing is then taken out of the refuse collecting container and attached thereto. Advantageous methods of doing this are explained more fully later on in the description.

[0020] The refuse container apparatus according to the invention is used in conjunction with an underground refuse collecting arrangement, particularly with an underground refuse collecting arrangement according to the invention as described hereinafter, so that all the remarks made concerning the refuse container apparatus apply in full to the underground refuse collecting arrangement as well, and *vice versa*.

[0021] The refuse container apparatus first of all comprises a refuse collecting container. The refuse collecting container defines a refuse receiving chamber and may have a capacity of up to several cubic metres, for example. In principle, the invention is not restricted either to a specific size or to a specific contour for the refuse collecting container. Advantageously, the refuse collecting container, as described in greater detail hereinafter, is introduced into an exterior housing set into the ground. Advantageously, the refuse collecting container in such cases has a contour that corresponds or at least approximates or is adapted to the contour of the exterior housing. The size of the refuse collecting container is advantageously selected so that it can be placed in the exterior housing with some play.

[0022] For example, the refuse collecting container first of all comprises a container base and a container side wall. For example, it may be that the refuse collecting container is rectangular in construction. For example, at least one emptying flap may be provided in the container base for emptying the refuse collecting container. For example, two or more flap elements may also be provided. For example, the container base may consist of two emptying flaps which are pivotably mounted on the side wall of the container. In another embodiment, two emptying flaps may be provided which are pivotably mounted on the container base.

[0023] Furthermore, the refuse collecting container comprises a lid element that forms the upper closure of the refuse collecting container and provides the upper boundary of the refuse receiving chamber. In the lid element is provided a receiving opening for refuse through which the refuse is conveyed into the refuse collecting container. If the cover element forms the upper closure of the refuse collecting container, it may be visible from outside, for example. If the refuse collecting container is set into an exterior housing as described in more detail

hereinafter, the lid element may come to rest on the side wall of the exterior housing, for example, and thus form a closure of the underground refuse collecting arrangement. In such a case it may be desirable for a user of the underground refuse collecting arrangement to stand on the lid element while he drops the refuse in. In this case the lid element also constitutes a platform for pedestrians. For this reason it is advantageous if the lid element is made from a suitably strong material, such as metal, for example.

[0024] A safety plate and/or a self-supporting platform may additionally be provided in the refuse collecting container.

[0025] Another component of the refuse container apparatus is the handling device. This may for example comprise a lifting device for lifting the refuse container apparatus and/or a device for actuating an emptying device for the refuse collecting container.

[0026] Advantageously, it is envisaged that the handling device is not part of the refuse collecting container, as was previously the case in the solutions known hitherto. Further advantageously, it is envisaged that the handling device for the refuse container apparatus is integrated in the drop-in housing. In this case, all the necessary components that are needed for handling the refuse container apparatus are arranged or formed inside the drop-in housing. In this way, it is possible to reduce the height of the refuse container apparatus before installation, for example during transporting, as the drop-in housing can be placed inside the refuse collecting container before assembly, as explained in greater detail hereinafter.

[0027] Also provided is preferably a connecting unit and/or a functional unit that can be at least partially arranged or formed in the refuse collecting container. This unit may comprise, in particular, a frame construction and additional bars, chains, cables and the like. In particular, this unit is attached to the handling device. Moreover, the unit may also be connected to an emptying device, for example to at least one emptying flap. In such a case, the handling device is connected to the emptying device via the unit, so that the emptying device can also be operated by means of the handling device.

[0028] Another component of the refuse container apparatus is formed by the drop-in housing for the refuse. The drop-in housing is provided above the receiving opening in the lid element of the refuse collecting container, in normal use of the refuse container apparatus, and comprises at least one drop-in opening for refuse. The refuse travels from the drop-in opening through the drop-in housing and through the receiving opening in the lid element into the refuse collecting container.

[0029] The drop-in housing comprises a drop-in chute in which the drop-in opening is located.

[0030] The drop-in housing may be constructed in different ways in terms of material, design and colour. For example, the drop-in housing may also carry a label, e.g. a written sign, colour marking or the like, to indicate what

type of refuse can be put in.

[0031] According to the invention the receiving opening in the lid element is larger in dimensions than the cross-section of the drop-in housing. Advantageously, as already explained above, it is provided that the drop-in housing may be arranged inside the refuse collecting container before assembly, for example when in transit. This also minimises the risk of damage before assembly. Delivery errors can also be minimised, as the refuse collecting container and the drop-in housing now form a unit before assembly.

[0032] To attach the drop-in housing to the refuse collecting container, the drop-in housing is pulled out of the receiving opening in the lid element of the refuse collecting container, which is easily done thanks to the dimensions according to the invention, and attached to the refuse collecting container. The embodiment according to the invention thus provides a larger hole in the lid element by comparison with the size of the drop-in housing, so that the drop-in housing can be pulled out of the interior of the refuse collecting container to the outside of the refuse collecting container. Attachment may be by simple means, for example from outside, and requires only minimal tools and know-how. After the drop-in housing has been taken out and fixed, the refuse container apparatus is ready for use.

[0033] The drop-in housing is releasably connected, or adapted to be connected, to the lid element of the refuse collecting container. In particular, the fixing device may be arranged or formed in the structure of the drop-in housing. This invention is not restricted to specific means of attachment.

[0034] According to the invention, the drop-in housing is connected, or adapted to be connected, to the refuse collecting container by means of a flange connection. The end region of the drop-in housing at the base end, which may correspond for example to the free lower end of the drop-in housing, is constructed as a flange or in the manner of a flange. A flange connection has the particular advantage that the drop-in housing can be tightly but releasably attached to the refuse collecting container. The crucial factor for a tight seal is the contact pressure of the sealing surfaces on a seal that is located, in particular, between them. The contact pressure may be applied for example by screws which are passed through bores located in the end region of the drop-in housing and in the lid element of the refuse collecting container around the receiving opening. Within the scope of a flange connection, it may be envisaged for example that the end region of the drop-in housing is constructed as such a flange, or that a corresponding flange is arranged in the end region of the drop-in housing, for example by means of a weld joint or the like. Preferably, the drop-in housing is attached to the lid element by screws, preferably with a simple gasket located in between.

[0035] During the assembly of the refuse container apparatus, the drop-in housing is pulled out of the receiving opening in the lid element of the refuse collecting con-

tainer. The flange region in the end region of the drop-in housing is then pulled towards the cover element from below, then abuts sealingly on the lid element from below, in other words from inside, and can then be secured by simple means, for example by screws.

[0036] In another embodiment, a cover element, particularly a cover plate, is provided for the receiving opening, the drop-in housing being releasably attached, or adapted to be attached, to the cover element. The cover element serves in particular to close off the receiving opening in the lid element of the refuse collecting container before or during assembly, for example during transportation or during the installation work, to prevent the unwanted ingress of water and/or dirt. For example, it may be envisaged that the drop-in housing is attached to the cover element in suspended manner, but preferably capable of being released. During assembly, the cover element is then lifted off the receiving opening, and at the same time the drop-in housing is also pulled out of the refuse receiving chamber of the refuse collecting container. After the drop-in housing has been attached to the lid element, the cover element can then be released from the drop-in housing.

[0037] According to a second aspect of the invention, an underground refuse collecting arrangement according to claim 4 is provided. In addition to the refuse container apparatus, the underground refuse collecting arrangement comprises an exterior housing. The exterior housing is placed in a prepared excavation in the ground and secured therein. It then serves to receive the refuse container apparatus and optionally other components.

[0038] The exterior housing may comprise an exterior housing base and an exterior housing wall, these components defining a receiving chamber for the other components of the underground refuse collecting arrangement. The exterior housing is advantageously open at the top. For example, the exterior housing may have a rectangular contour. Moreover, the invention is not restricted to specific materials for the exterior housing. It may be made of concrete, for example.

[0039] Preferably, the exterior housing has a maximum height of less than or equal to 2.70 m.

[0040] In addition to the refuse container apparatus, a safety system, preferably with a safety platform, may also be provided, for example, the safety system being provided on and/or in the exterior housing. A safety platform serves to close off the opening in the exterior housing when the refuse container apparatus is not in the exterior housing. For example, the safety platform may be connected to and interact with a counterweight construction, so that the safety platform automatically rises as the refuse container apparatus is lifted out. Naturally, the safety system may also be of a different construction, for example using spring-loaded safety valves that close automatically when the refuse container apparatus is lifted out.

[0041] According to the third aspect of the invention, a construction set according to claim 8 is provided for an

underground refuse collecting arrangement, particularly for an underground refuse collecting arrangement according to the invention as hereinbefore described.

[0042] Compared with the underground refuse collecting arrangement described hereinbefore that is already pre-assembled and thus ready for use, according to the third aspect of the invention a set of individual, unassembled or partly assembled components is claimed.

[0043] The construction set advantageously comprises an exterior housing as hereinbefore described, a refuse collecting container as hereinbefore described and a drop-in housing as hereinbefore described, in which the drop-in housing and refuse collecting container are, in particular, not yet connected to one another. A safety system may also be provided, advantageously with a safety platform.

[0044] Advantageously, during the transporting of the construction set and/or prior to the assembly of the construction set, all the components of the construction set may be fitted one inside the other. This means, in particular, that the components needed are disposed within the exterior housing.

[0045] For example, a safety system may already be pre-assembled in the exterior housing. The refuse collecting container of the refuse container apparatus may be arranged in the exterior housing. The drop-in housing is initially inside the refuse collecting container. For example, the drop-in housing may be mounted within the refuse collecting container by being suspended from a cover element for the receiving opening in the lid element of the refuse collecting container.

[0046] According to fourth aspect of the invention, a method of assembling an underground refuse collecting arrangement using a construction set according to the invention as hereinbefore described, is provided, which comprises the features of independent claim 12.

[0047] An advantageous feature of this embodiment is that the exterior housing, the safety system, the refuse collecting container and the drop-in housing can all be unloaded together from a transporting vehicle by a lifting system, for example a crane, and placed in the prepared excavated site in a single operation. The unloading and installation of the entire system can thus take place in a single operation. Inconvenience to the users, unloading times for haulage vehicles, e.g. trucks, and hire periods for equipment such as cranes can thus be reduced to a minimum.

[0048] After the construction set with the components contained in the exterior housing has been placed at the desired site, all that remains is to remove the drop-in housing from the refuse collecting container and secure it. The underground refuse collecting arrangement is then ready for use.

[0049] Advantageously, it is provided that the construction set has a maximum height of less than or equal to 2.70 m during transporting and/or prior to assembly. This ensures that the underground refuse collecting arrangement, which initially takes the form of a construction

set, can be transported by simpler vehicles, and also substantially more easily. It is particularly advantageous that the handling device for the refuse container apparatus is integrated in the drop-in housing.

[0050] The solutions according to the invention additionally have a number of other general advantages. Thus, the main components of the underground refuse collecting arrangement can be brought together at a single location, which is advantageously not the installation site, and put together, possibly even pre-assembled, in the form of the construction set. The delivery chain can be managed directly between the manufacturers of the individual components. Maximum efficiency can be achieved by centralising these preparatory steps. At the same time, error rates in the planning and delivery of the individual components can be minimised. The implementation and installation of the underground refuse collecting arrangement at the installation site can be carried out according to the modular principle. Finally, the number of operatives needed for the assembly on the installation site can be reduced as a result.

[0051] The invention will now be explained in more detail by means of an embodiment by way of example, with reference to the attached drawings, wherein:

Figures 1 to 3 show the various components of an underground refuse collecting arrangement according to the invention;
 Figure 4 shows a construction set of the underground refuse collecting arrangement according to the invention at the start of assembly;
 Figure 5 shows, in greater detail, the connecting process for connecting the drop-in housing to the refuse collecting container; and
 Figure 6 shows the construction set of the underground refuse collecting arrangement according to the invention at the end of assembly.

[0052] Figures 1 to 3 show first of all the individual components of an underground refuse collecting arrangement 10 according to the invention.

[0053] Figure 1 shows an exterior housing 12, that can be set into a prepared excavated site. The exterior housing 12, which is advantageously made of concrete, preferably has an overall height of less than or equal to 2.70 m. The exterior housing 12 comprises a receiving chamber 15 for further components of the underground refuse collecting arrangement 10. The receiving chamber 15 is bounded by an exterior housing base 13 and an exterior housing wall 14. At the top, the exterior housing 12 is bounded by a housing opening 16 which extends over the entire cross-section of the housing. Other components can be introduced into the exterior housing 12 through the housing opening 16. The exterior housing 12 has a rectangular contour or a rectangular cross-section,

for example.

[0054] Pre-assembled in the exterior housing 12 is a safety system 17 which has a safety platform 18. The safety platform 18 may for example cooperate with a system of counterweights. When a refuse container apparatus is lifted out of the exterior housing 12 during normal use, the safety platform 18 moves upwards and closes off the housing opening 16.

[0055] Figure 2 shows a further component of the underground refuse collecting arrangement 10, which is a refuse container apparatus 11. The refuse container apparatus 11 first of all comprises a refuse collecting container 20. The refuse collecting container 20 has a refuse receiving chamber 24 which is bounded by a container base 21, a container side wall 22 and a lid element 23. The refuse collecting container 20 has a rectangular contour or a rectangular cross-section, for example.

[0056] The lid element 23 may also act as a platform for pedestrians. For this reason it is advantageous if the lid element 23 is made from a suitably strong material, such as metal, for example.

[0057] For receiving refuse, a corresponding receiving opening 25 is provided in the lid element 23.

[0058] In addition, in the refuse collecting container 20 a connecting unit and/or functional unit may be provided, which is shown purely schematically in Figure 2 and is designated by reference numeral 26. This unit 26 may comprise, in particular, a frame construction and additional bars, chains, cables and the like. In particular, the unit 26 is connected to a handling device 30 which is shown in Figure 3. Moreover, the unit 26 may also be connected to an emptying device, for example with at least one emptying flap in the container base 21. In such a case, the handling device 30 is connected to the emptying device via the unit 26, so that the emptying device can also be operated by means of the handling device 30.

[0059] Figure 3 shows a drop-in housing 40 for the refuse container apparatus 11 of the underground refuse collecting arrangement 10. The drop-in housing 40 comprises a drop-in chute 41 in which is provided at least one drop-in opening 42 for refuse. In addition, a signage area 43 may also be provided for indicating the nature of the refuse to be disposed therein, in this case paper. Moreover, a handling device 30 for handling the refuse container apparatus 20 is integrated in the drop-in housing 40. The handling device 30 comprises a lifting device 31 by means of which the drop-in housing 40 and the refuse collecting container 20 attached thereto can be hoisted, for example using a crane.

[0060] For attaching the drop-in housing 40 to the refuse collecting container 20, the drop-in housing 40 comprises a flange connection 44 in the lower end region 45 of the drop-in chute 41, i.e. in the region of the free lower end of the drop-in housing 40. The drop-in housing 40 is attached to the refuse collecting container 20 by means of the flange connection 44, as described hereinafter.

[0061] Figures 4 to 6 show how a construction set con-

sisting of the above-mentioned individual components is assembled to form an underground refuse collecting arrangement 10. First of all, an excavated site in the ground is prepared into which the exterior housing 12 can be lowered.

[0062] A construction set is then delivered, consisting of the exterior housing 12 and the safety system 17 pre-assembled therein. The construction set also comprises the refuse collecting container 20 and the drop-in housing 40. The drop-in housing 40 is not yet attached to the refuse collecting container 20. Rather, the drop-in housing is suspended from a cover element 50 in the form of a cover plate. The cover element 50 has the function of closing off the receiving opening 25 in the lid element 23 of the refuse collecting container 20 prior to assembly, for example during transportation as well, to prevent water and dirt from penetrating into the refuse collecting container. Preferably the maximum height H of the construction set is less than or equal to 2.70 m, making the transporting of the construction set considerably easier.

[0063] As can be seen from Figure 5 in particular, the receiving opening 25 has a diameter X that is greater than the dimension Y of the cross-section of the drop-in housing 40. In order to secure the drop-in housing 40 to the lid element 25 of the refuse collecting container 20, the drop-in housing 40 initially located inside the refuse collecting container 20 is pulled out through the receiving opening 25 until the end region 45 of the drop-in housing 40 that forms the flange connection 44 makes contact with the lid element 23 from inside. A sealing element 46 is advantageously provided in between; in Figure 5 the sealing element 46 is shown only on the lefthand side of the Figure, for illustration purposes. Naturally, the sealing element 46 is advantageously of circumferential configuration. After the drop-in housing 40 has been pulled out of the receiving opening 25, the drop-in housing 40 can be attached to the lid element 20 by means of the flange connection 44, for example by screwing.

[0064] The finished assembled underground refuse collecting arrangement 10 is shown in Figure 6. After the drop-in housing 40 has been removed from the refuse collecting container 20 and secured thereto, the underground refuse collecting arrangement 10 is ready for use.

45 List of reference numerals

[0065]

10	underground refuse collecting arrangement
11	refuse container apparatus
12	exterior housing
13	exterior housing base
14	exterior housing wall
15	receiving chamber
16	exterior housing opening
17	safety system
18	safety platform

20 refuse collecting container
 21 container base
 22 container side wall
 23 lid element
 24 refuse receiving chamber
 25 receiving opening
 26 connecting unit/functional unit

30 handling device
 31 lifting device

40 drop-in housing
 41 disposal chute
 42 drop-in opening
 43 signage area
 44 flange connection
 45 end region
 46 sealing element

50 cover element

H maximum height of construction set

Claims

1. A refuse container apparatus (11) for an underground refuse collecting arrangement (10), having a refuse collecting container (20) which comprises a lid element (23) that closes off the refuse collecting container (20) at the top, wherein a receiving opening (25) for refuse is provided in said lid element (23), with a handling device (30) for the refuse container apparatus (11) and with a drop-in housing (40) for refuse that is provided above the receiving opening (25), that is releasably connected or adapted to be connected to the lid element (23), said drop-in housing (40) comprising a drop-in chute (41), wherein at least one drop-in opening (42) for refuse is provided in said drop-in chute (41),

characterised in that

the receiving opening (25) in the lid element (23) has a diameter (X) that is greater than the dimension (Y) of the cross-section of the drop-in chute (41), and that the drop-in housing (40) comprises a flange connection (44) in the lower end region (43) of the drop-in chute (41), which releasably connects the drop-in housing (40) to the lid element (23) by making contact with the lid element (23) from inside the refuse collecting container (20) by having the drop-in housing (40) being pulled out from the interior of the refuse collecting container (20) through the receiving opening (25).

2. The refuse container apparatus according to claim 1, **characterised in that** the handling device (30) for the refuse container apparatus (11) is integrated in the drop-in housing (40).

3. The refuse container apparatus according to claim 2, **characterised in that** the handling device (30) comprises a lifting device (31) for lifting the refuse container apparatus (11), by means of which the drop-in housing (40) and the refuse collecting container (20) attached thereto can be hoisted.

4. An underground refuse collecting arrangement (10), having an exterior housing (12) which accommodates a refuse container apparatus (11) according to claim 1.

5. The underground refuse collecting arrangement according to claim 4, **characterised in that** the refuse container apparatus (11) is configured according to anyone of claims 2 or 3.

6. The underground refuse collecting arrangement according to claim 4 or 5, **characterised in that** a safety system (17) is provided, and **in that** the safety system (17) is provided in the exterior housing (12).

7. The underground refuse collecting arrangement according to claim 6, **characterised in that** the safety system (17) has a safety platform (18).

8. A construction set for an underground refuse collecting arrangement (10), said construction set comprising an exterior housing (12) and a refuse container apparatus (11) according to claim 1, which is disposed within the exterior housing (12), wherein the drop-in housing (40) of the refuse container apparatus (11) is fitted inside the refuse collecting container (20) of the refuse container apparatus (11) and is not yet connected to the lid element (23).

9. The construction set according to claim 8, **characterised in that** the underground refuse collecting arrangement (10) is configured according to anyone of claims 5 to 7.

10. The construction set according to claim 8 or 9, **characterised in that** a safety system (17) of the underground refuse collecting arrangement (10) is already pre-assembled in the exterior housing (12) of the underground refuse collecting arrangement (10).

11. The construction set according to anyone of claims 8 to 10, **characterised in that** the construction set has a maximum height of less than or equal to 2.70 m prior to assembly.

12. A method of assembling an underground refuse collecting arrangement using a construction set according to anyone of claims 8 to 11, said method being **characterized by** the following steps: the exterior housing, in which the refuse collecting apparatus is disposed, is placed in a prepared excavation in the

ground and secured therein;
 the drop-in housing that is located inside the refuse collecting container, is pulled out of the receiving opening in the lid element of the refuse collecting container until the flange connection of the drop-in housing makes contact with the lid element from inside the refuse collecting container (20);
 once the drop-in housing has been pulled out from the interior of the refuse collecting container through the receiving opening and the flange connection of the drop-in housing has made contact with the lid element, the drop-in housing is attached to the lid element by means of the flange connection.

Patentansprüche

1. Abfallbehältervorrichtung (11) für eine Unterflur-Abfallsammelanordnung (10), mit einem Abfallsammelbehälter (20), der ein den Abfallsammelbehälter (20) nach oben abschließendes Deckenelement (23) aufweist, wobei in dem Deckenelement (23) eine Aufnahmeöffnung (25) für Abfall bereitgestellt ist, mit einer Handhabungseinrichtung (30) für die Abfallbehältervorrichtung (11) und mit einem Einwurfgehäuse (40) für Abfall, welches oberhalb der Aufnahmeöffnung (25) bereitgestellt ist, das mit dem Deckenelement (23) lösbar verbunden oder verbindbar ist, wobei das Einwurfgehäuse (40) eine Einwurfsäule (41) aufweist, wobei wenigstens eine Einwurföffnung (42) für Abfall in der Einwurfsäule (41) bereitgestellt ist, **dadurch gekennzeichnet, dass** die Aufnahmeöffnung (25) im Deckenelement (23) einen Durchmesser (X) hat, der größer ist als die Dimension (Y) des Querschnitts der Einwurfsäule (41), und dass das Einwurfgehäuse (40) eine Flanschverbindung (40) im unteren Endbereich (43) der Einwurfsäule (41) aufweist, welche das Einwurfgehäuse (40) lösbar mit dem Deckenelement (23) verbindet, indem sie mit dem Deckenelement (23) von innerhalb des Abfallsammelbehälters (20) einen Kontakt herstellt, wenn das Einwurfgehäuse (40) durch die Aufnahmeöffnung (25) aus dem Inneren des Abfallsammelbehälters (20) herausgezogen wurde.
2. Abfallbehältervorrichtung nach Anspruch 1, **dadurch gekennzeichnet, dass** die Handhabungseinrichtung (30) für die Abfallbehältervorrichtung (11) in dem Einwurfgehäuse (40) integriert ist.
3. Abfallbehältervorrichtung nach Anspruch 2, **dadurch gekennzeichnet, dass** die Handhabungseinrichtung (30) eine Hebeeinrichtung (31) zum Anheben der Abfallbehältervorrichtung (11) aufweist, mittels derer das Einwurfgehäuse (40) und der daran angeordnete Abfallsammelbehälter (20) hochgezogen werden können.

4. Unterflur-Abfallsammelanordnung (10), mit einem Außengehäuse (12), welches eine Abfallbehältervorrichtung (11) nach Anspruch 1 aufnimmt.
5. Unterflur-Abfallsammelanordnung nach Anspruch 4, **dadurch gekennzeichnet, dass** die Abfallbehältervorrichtung (11) nach einem der Ansprüche 2 oder 3 ausgebildet ist.
6. Unterflur-Abfallsammelanordnung nach Anspruch 4 oder 5, **dadurch gekennzeichnet, dass** ein Sicherheitssystem (17) bereitgestellt ist, und dass das Sicherheitssystem (17) im Außengehäuse (12) bereitgestellt ist.
7. Unterflur-Abfallsammelanordnung nach Anspruch 6, **dadurch gekennzeichnet, dass** das Sicherheitssystem (17) eine Sicherheitsplattform (18) hat.
8. Bausatz für eine Unterflur-Abfallsammelanordnung (10), wobei der Bausatz ein Außengehäuse (12) und eine Abfallbehältervorrichtung (11) nach Anspruch 1 aufweist, welche innerhalb des Außengehäuses (12) angeordnet ist, wobei das Einwurfgehäuse (40) der Abfallbehältervorrichtung (11) in dem Abfallsammelbehälter (20) der Abfallbehältervorrichtung (11) eingebaut und noch nicht mit dem Deckenelement (23) verbunden ist.
9. Bausatz nach Anspruch 8, **dadurch gekennzeichnet, dass** die Unterflur-Abfallsammelanordnung (10) nach einem der Ansprüche 5 bis 7 ausgebildet ist.
10. Bausatz nach Anspruch 8 oder 9, **dadurch gekennzeichnet, dass** ein Sicherheitssystem (17) der Unterflur-Abfallsammelanordnung (10) in dem Außengehäuse (12) der Unterflur-Abfallsammelanordnung (10) bereits vormontiert ist.
11. Bausatz nach einem der Ansprüche 8 bis 10, **dadurch gekennzeichnet, dass** der Bausatz vor der Montage eine maximale Höhe von kleiner oder gleich 2.70 m aufweist.
12. Verfahren zur Montage einer Unterflur-Abfallsammelanordnung unter Verwendung eines Bausatzes nach einem der Ansprüche 8 bis 11, wobei das Verfahren durch die folgenden Schritte gekennzeichnet ist:
 - das Außengehäuse, in welchem die Abfallsammelvorrichtung angeordnet ist, wird in einer präparierten Aushebung im Boden platziert und darin gesichert;
 - das Einwurfgehäuse, das sich innerhalb des Abfallsammelbehälters befindet, wird aus der Aufnahmeöffnung im Deckenelement des Abfall-

sammelbehälters herausgezogen, bis die Flanschverbindung des Einwurfgehäuses von innerhalb des Abfallsammelbehälters (20) mit dem Deckelelement in Kontakt kommt; sobald das Einwurfgehäuse aus dem Inneren des Abfallsammelbehälters durch die Aufnahmeöffnung herausgezogen wurde und die Flanschverbindung des Einwurfgehäuses mit dem Deckelelement in Kontakt gekommen ist, wird das Einwurfgehäuse mittels der Flanschverbindung an dem Deckelelement befestigt.

Revendications

1. Appareil de conteneur à déchets (11) pour un agencement de collecte de déchets souterrain (10), ayant un conteneur de collecte de déchets (20) qui comprend un élément de couvercle (23) qui ferme le conteneur de collecte de déchets (20) sur le haut, dans lequel une ouverture de réception (25) de déchets est aménagée dans ledit élément de couvercle (23), avec un dispositif de manutention (30) pour l'appareil de conteneur à déchets (11) et avec un logement de dépose (40) de déchets qui est aménagé au-dessus de l'ouverture de réception (25), qui est raccordé ou adapté pour être raccordé de façon amovible à l'élément de couvercle (23), ledit logement de dépose (40) comprenant une glissière de dépose (41), dans lequel au moins une ouverture de dépose (42) de déchets est aménagée dans ladite glissière de dépose (41),
caractérisé en ce que l'ouverture de réception (25) dans l'élément de couvercle (23) a un diamètre (X) qui est plus grand que la dimension (Y) de la section transversale de la glissière de dépose (41), et **en ce que** le logement de dépose (40) comprend un raccord à bride (44) dans la région d'extrémité inférieure (43) de la glissière de dépose (41), qui raccorde de façon amovible le logement de dépose (40) à l'élément de couvercle (23) en établissant un contact avec l'élément de couvercle (23) depuis l'intérieur du conteneur de collecte de déchets (20) en extrayant le logement de dépose (40) de l'intérieur du conteneur de collecte de déchets (20) par l'ouverture de réception (25).
2. Appareil de conteneur à déchets selon la revendication 1, **caractérisé en ce que** le dispositif de manutention (30) de l'appareil de conteneur à déchets (11) est intégré dans le logement de dépose (40).
3. Appareil de conteneur à déchets selon la revendication 2, **caractérisé en ce que** le dispositif de manutention (30) comprend un dispositif de levage (31) pour lever l'appareil de conteneur à déchets (11), au moyen duquel le logement de dépose (40) et le conteneur de collecte de déchets (20) attaché à celui-ci

peuvent être soulevés.

4. Agencement de collecte de déchets souterrain (10), ayant un logement extérieur (12) qui reçoit un appareil de conteneur à déchets (11) selon la revendication 1.
5. Agencement de collecte de déchets souterrain selon la revendication 4, **caractérisé en ce que** l'appareil de conteneur à déchets (11) est configuré selon l'une quelconque des revendications 2 ou 3.
6. Agencement de collecte de déchets souterrain selon la revendication 4 ou 5, **caractérisé en ce que** un système de sécurité (17) est aménagé, et **en ce que** le système de sécurité (17) est aménagé dans le logement extérieur (12).
7. Agencement de collecte de déchets souterrain selon la revendication 6, **caractérisé en ce que** le système de sécurité (17) a une plateforme de sécurité (18).
8. Ensemble de construction pour un agencement de collecte de déchets souterrain (10), ledit ensemble de construction comprenant un logement extérieur (12) et un appareil de conteneur à déchets (11) selon la revendication 1, qui est disposé dans le logement extérieur (12), dans lequel le logement de dépose (40) de l'appareil de conteneur à déchets (11) est intégré à l'intérieur du conteneur de collecte de déchets (20) de l'appareil de conteneur à déchets (11) et n'est pas encore raccordé à l'élément de couvercle (23).
9. Ensemble de construction selon la revendication 8, **caractérisé en ce que** l'agencement de collecte de déchets souterrain (10) est configuré selon l'une quelconque des revendications 5 à 7.
10. Ensemble de construction selon la revendication 8 ou 9, **caractérisé en ce que** un système de sécurité (17) de l'agencement de collecte de déchets souterrain (10) est déjà pré-assemblé dans le logement extérieur (12) de l'agencement de collecte de déchets souterrain (10).
11. Ensemble de construction selon l'une quelconque des revendications 8 à 10, **caractérisé en ce que** l'ensemble de construction a une hauteur maximale inférieure ou égale à 2,70 m avant assemblage.
12. Procédé d'assemblage d'un agencement de collecte de déchets souterrain utilisant un ensemble de construction selon l'une quelconque des revendications 8 à 11, ledit procédé étant **caractérisé par** les étapes suivantes : le logement extérieur, dans lequel l'appareil de collecte à déchets est disposé, est placé dans une excavation préparée dans le sol et est fixé

dans celle-ci ;

le logement de dépose qui est situé à l'intérieur du conteneur de collecte de déchets, est extrait de l'ouverture de réception dans l'élément de couvercle du conteneur de collecte de déchets jusqu'à ce que le raccord à bride du logement de dépose établisse un contact avec l'élément de couvercle de l'intérieur du conteneur de collecte de déchets (20) ;

une fois que le logement de dépose a été extrait de l'intérieur du conteneur de collecte de déchets par l'ouverture de réception et que le raccord à bride du logement de dépose a établi un contact avec l'élément de couvercle, le logement de dépose est attaché à l'élément de couvercle au moyen du raccord à bride.

5

10

15

20

25

30

35

40

45

50

55

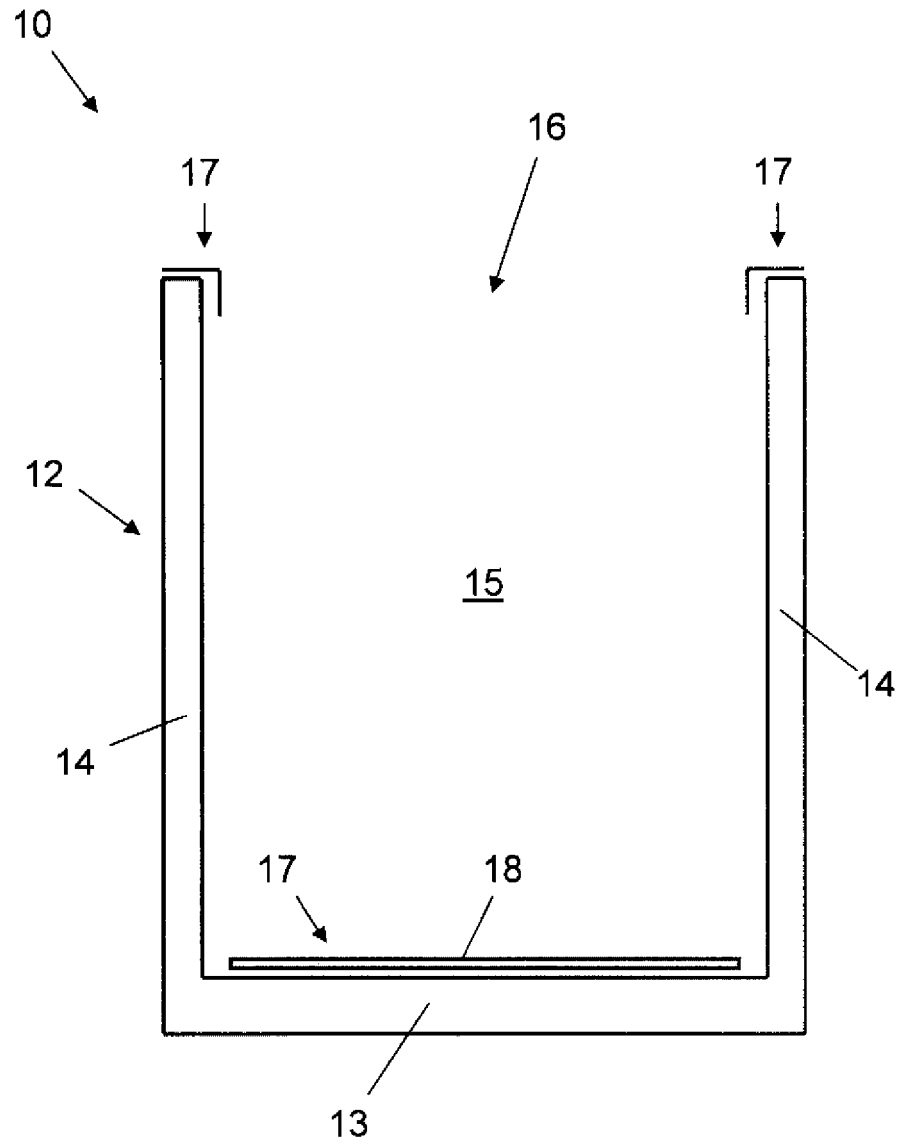

Fig. 1

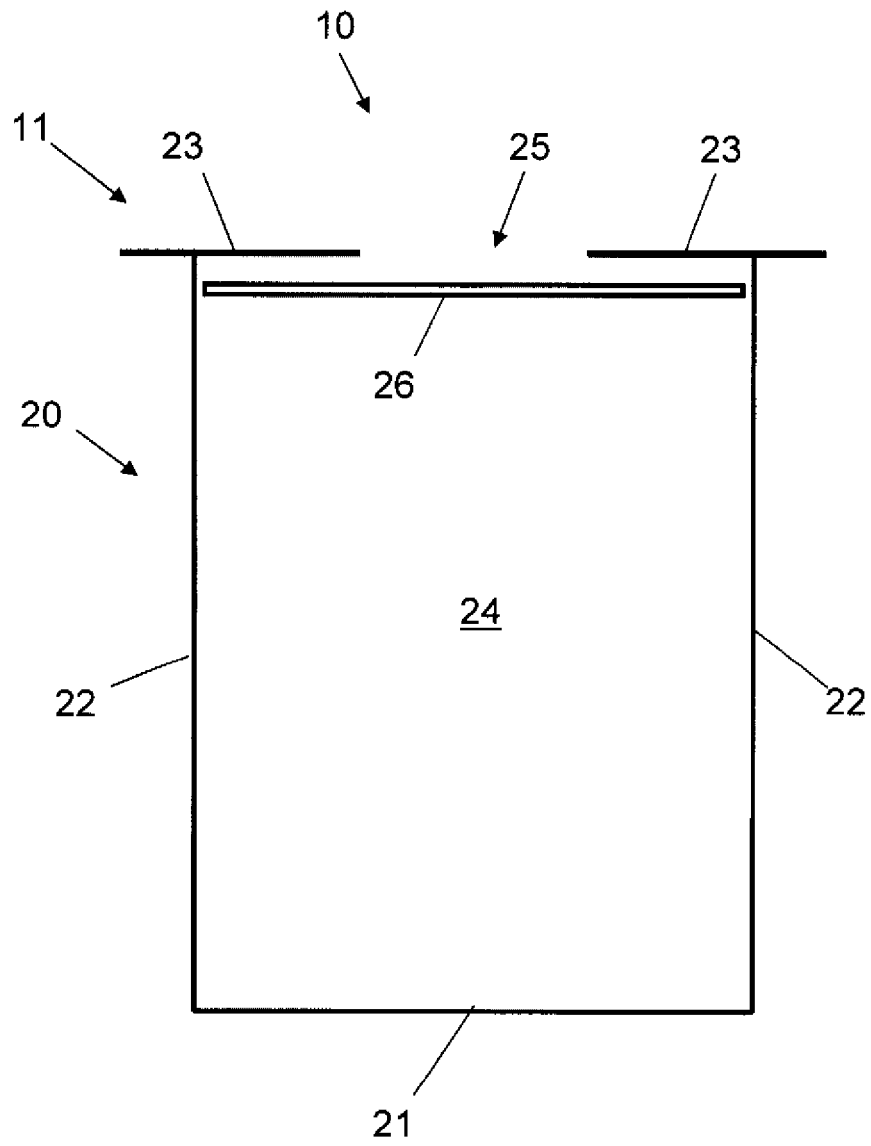

Fig. 2

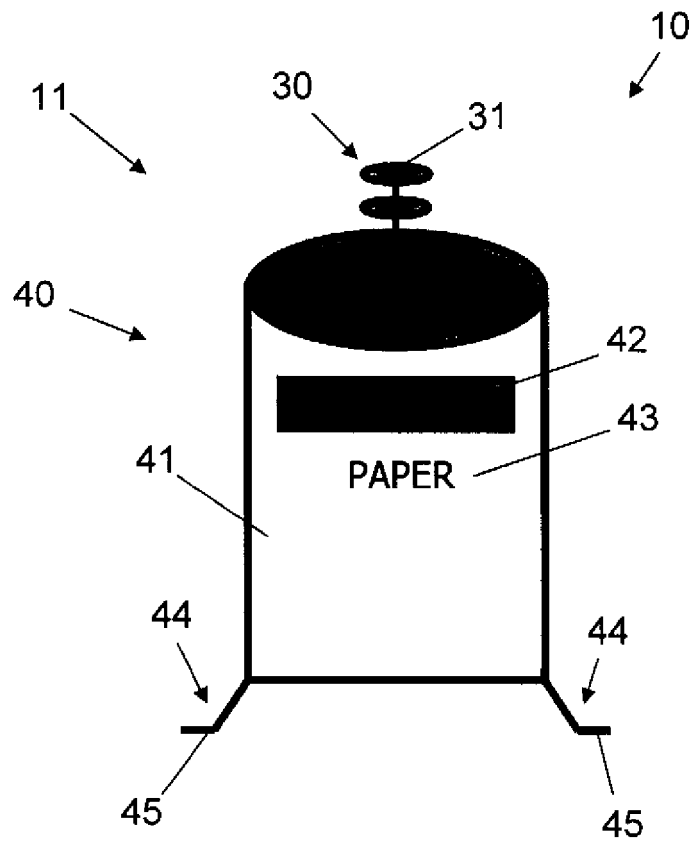

Fig. 3

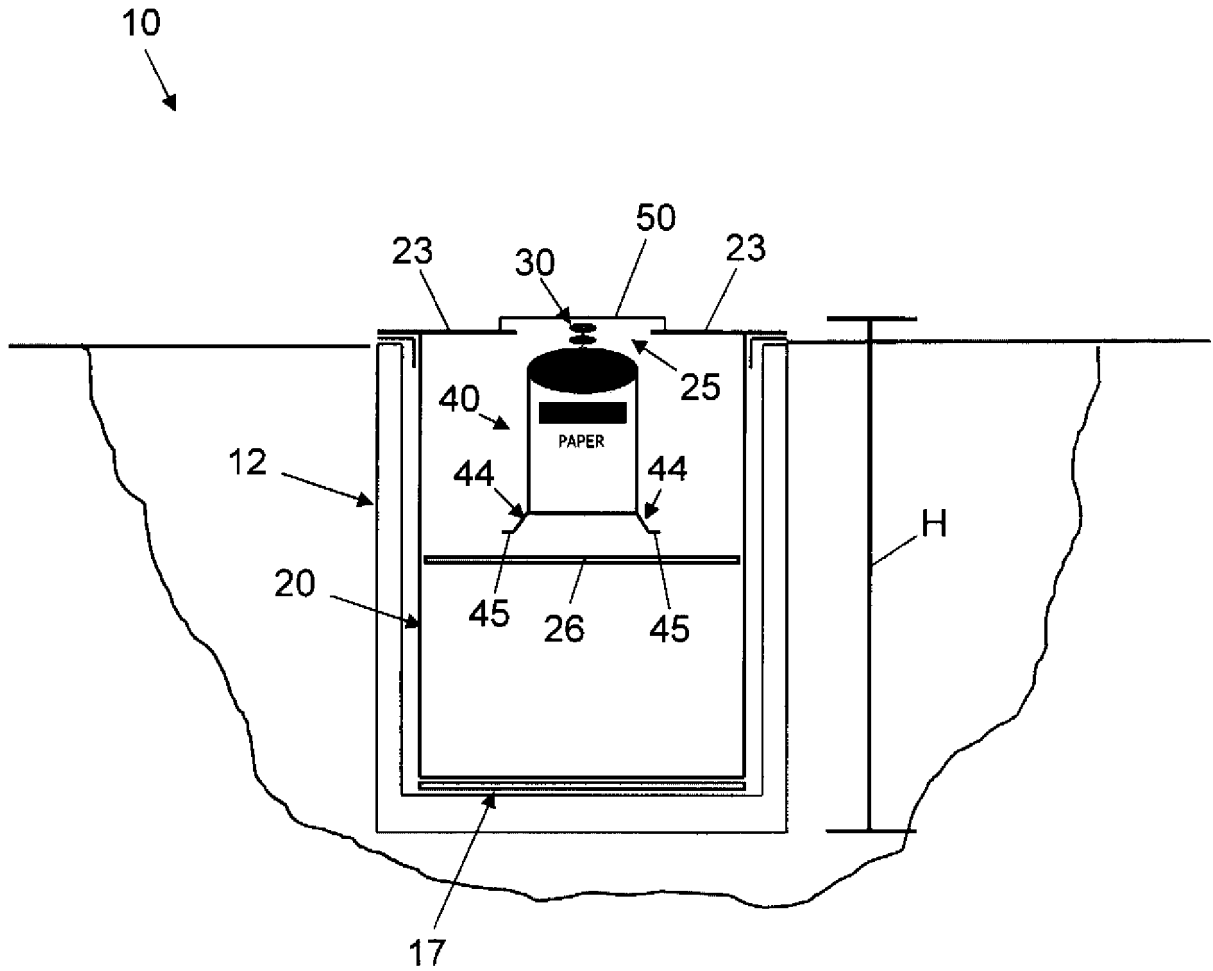

Fig. 4

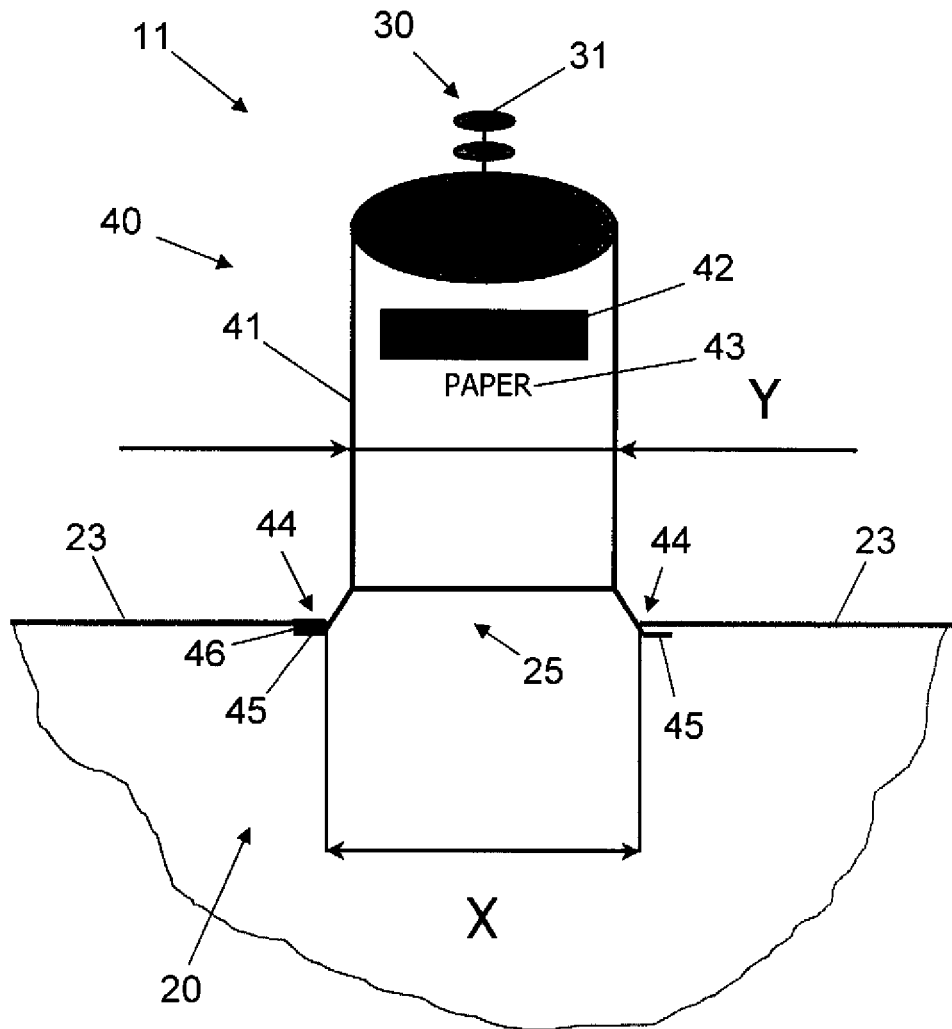

Fig. 5

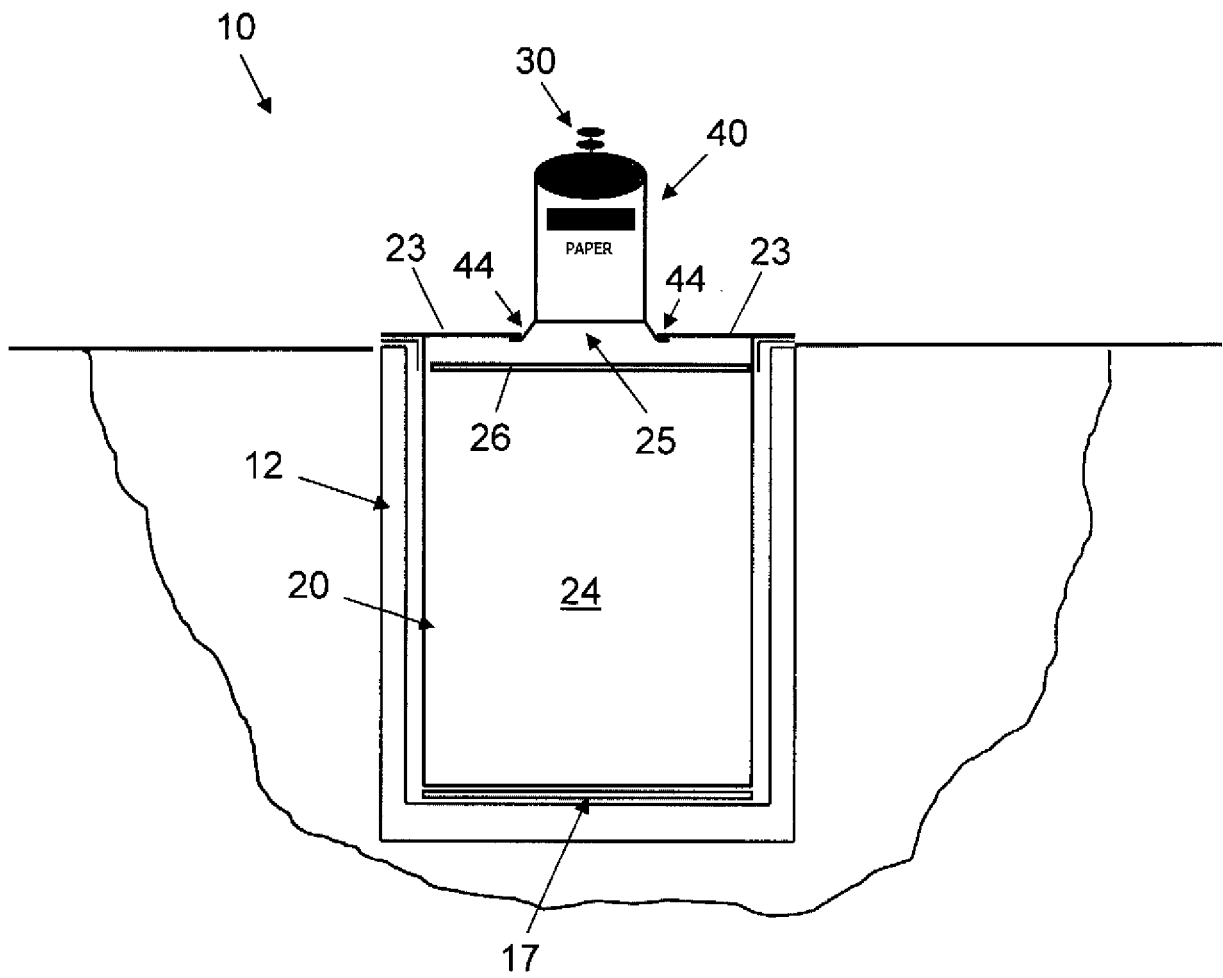

Fig. 6

REFERENCES CITED IN THE DESCRIPTION

This list of references cited by the applicant is for the reader's convenience only. It does not form part of the European patent document. Even though great care has been taken in compiling the references, errors or omissions cannot be excluded and the EPO disclaims all liability in this regard.

Patent documents cited in the description

- DE 29923490 U1 [0009]
- AU 2006204645 B2 [0009]