

(19) World Intellectual Property Organization
International Bureau



(43) International Publication Date
3 July 2008 (03.07.2008)

PCT

(10) International Publication Number
WO 2008/079588 A1

(51) International Patent Classification:
H01R 24/02 (2006.01)

(74) Agents: BURTIS, John, A. et al.; 3M Center, Office of Intellectual Property Counsel, Post Office Box 33427, Saint Paul, MN 55133-3427 (US).

(21) International Application Number:
PCT/US2007/085995

(81) Designated States (unless otherwise indicated, for every kind of national protection available): AE, AG, AL, AM, AT, AU, AZ, BA, BB, BG, BH, BR, BW, BY, BZ, CA, CH, CN, CO, CR, CU, CZ, DE, DK, DM, DO, DZ, EC, EE, EG, ES, FI, GB, GD, GE, GH, GM, GT, HN, HR, HU, ID, IL, IN, IS, JP, KE, KG, KM, KN, KP, KR, KZ, LA, LC, LK, LR, LS, LT, LU, LY, MA, MD, ME, MG, MK, MN, MW, MX, MY, MZ, NA, NG, NI, NO, NZ, OM, PG, PH, PL, PT, RO, RS, RU, SC, SD, SE, SG, SK, SL, SM, SV, SY, TJ, TM, TN, TR, TT, TZ, UA, UG, US, UZ, VC, VN, ZA, ZM, ZW.

(22) International Filing Date:
30 November 2007 (30.11.2007)

(25) Filing Language: English

(26) Publication Language: English

(30) Priority Data:
06126733.2 20 December 2006 (20.12.2006) EP

(84) Designated States (unless otherwise indicated, for every kind of regional protection available): ARIPO (BW, GH, GM, KE, LS, MW, MZ, NA, SD, SL, SZ, TZ, UG, ZM, ZW), Eurasian (AM, AZ, BY, KG, KZ, MD, RU, TJ, TM), European (AT, BE, BG, CH, CY, CZ, DE, DK, EE, ES, FI, FR, GB, GR, HU, IE, IS, IT, LT, LU, LV, MC, MT, NL, PL, PT, RO, SE, SI, SK, TR), OAPI (BF, BJ, CF, CG, CI, CM, GA, GN, GQ, GW, ML, MR, NE, SN, TD, TG).

(71) Applicant (for all designated States except US): 3M INNOVATIVE PROPERTIES COMPANY [US/US]; 3M Center, Post Office Box 33427, Saint Paul, MN 55133-3427 (US).

(72) Inventors; and

(75) Inventors/Applicants (for US only): DESARD, Christophe [FR/FR]; Boulevard de l'Oise, F-95006 Cergy Pontoise Cedex (FR). TOUILLON, Didier [FR/FR]; Boulevard de l'Oise, F-95006 Cergy Pontoise Cedex (FR). MARSAC, Yvonnick [FR/FR]; Boulevard de l'Oise, F-95006 Cergy Pontoise Cedex (FR).

Published:

- with international search report
- before the expiration of the time limit for amending the claims and to be republished in the event of receipt of amendments

(54) Title: CONNECTION ARTICLE FOR A CABLE, HOLDER FOR A CONNECTOR OF SUCH A CONNECTION ARTICLE, AND KIT FOR CONNECTING CABLES

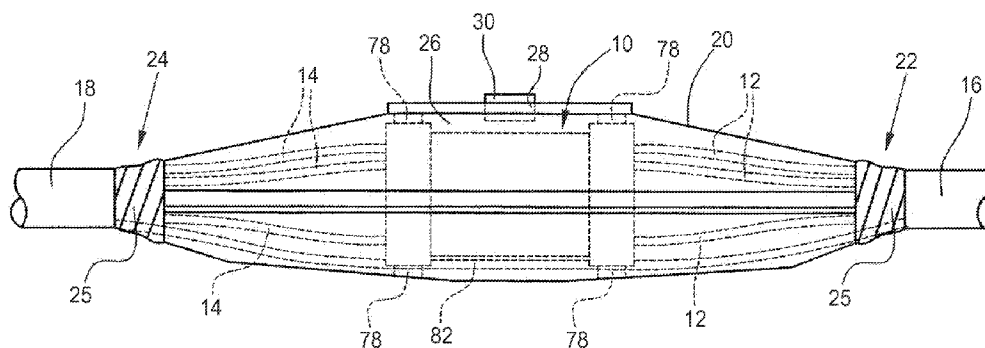

(57) Abstract: A connection article is provided for a cable comprising at least one wire. The connection article comprises a holder, at least one connector arranged in the holder and having a first receiving opening for receiving a wire to be connected, and guiding means arranged in front of the first receiving opening of the at least one connector, the first receiving opening defining a cross section and the guiding means comprising at least one guiding passage extending through the guiding means and aligned with the first receiving opening of the at least one connector for guiding a wire into the first receiving opening of the connector. The at least one guiding passage comprises opposite distal and proximal ends, the proximal end facing towards and the distal end facing away from the first receiving opening of the at least one connector. The proximal end has a cross section not larger than the cross section of the first receiving opening of the at least one connector. The distal end has a cross section larger than the cross section of the proximal end.



WO 2008/079588 A1

cables or wires separated from each other. The use of the known wire spacers for electrical connectors is rather complicated because the individual connectors have to be arranged around the wire spacers, which is time consuming and requires some training and experience.

5 Guiding means for aligning mating connector elements of a connection article are basically known. These known connection assemblies require two connector elements for each cable to be connected wherein the connector elements are guided relatively to each other. One example of such a connection article is disclosed in US-A-2005/0271328. The known systems require the termination of the wires to be connected at the mating
10 connector elements which again results in the problem mentioned above if the wires are rather rigid due to the size of their cross sections.

 From EP-8-1 180 823 a cable connection article is known in which individual pins of one mating connector element penetrate between the individual parallel conductor fibers of the wires of a cable fixedly arranged in the other mating connector element. In
15 such a connector there is the risk that the electrical connection between the pins and the conductor fibers of the individual cables is not reliable.

 In order to facilitate the insertion of wires in the receiving openings of electrical connectors it is known to provide the connection article with insertion guiding means. An example of such a connection article is disclosed in EP-B-0 763 873. The known insertion
20 guiding means comprises a guiding passage having a conical shape and being tapered towards the connector receiving opening. However, in the known connection article it is still necessary that the individual wires are inserted into the connectors in a direction more or less parallel to the longitudinal extension of the connectors. Namely, otherwise it is still possible (and to be expected in particular for stiff wires) that the individual wires could
25 contact an edge around the receiving openings of the individual connectors.

 From DE-A-32 02 747 a plug is known comprising insertion funnel passages for connecting the wires of a cable to contact pins of the plug.

 Another requirement for a multi-wire cable connection article is easy access to the fastening means (such as screws or the like) of the individual connectors. In particular,
30 when the connectors are arranged for providing a compact connection article requiring only little space, an easy access to the fastening elements is still necessary.

 Accordingly, there is a need for improved connection article fulfilling the above-

mentioned requirements in an easy manner and which is easy to handle.

Summary

The present invention provides a connection article for a cable comprising at least
5 one wire, wherein the connection article comprises

- a holder,
- at least one connector arranged in the holder and having a first receiving opening for receiving a wire to be connected, and
- 10 guiding means arranged in front of the first receiving opening of the at least one connector, the first receiving opening defining a cross section and the guiding means comprising at least one guiding passage extending through the guiding means and aligned with the first receiving opening of the at least one connector for guiding a wire into the first receiving opening of the connector,
- 15 - wherein the at least one guiding passage comprises opposite distal and proximal ends, the proximal end facing towards and the distal end facing away from the first receiving opening of the at least one connector,
- wherein the proximal end has a cross section not larger than the cross section of the first receiving opening of the at least one connector,
- 20 - wherein the distal end has a cross section larger than the cross section of the proximal end,
- wherein the distal end has a cross section larger than the cross section of the proximal end, wherein the at least one connector comprises a second receiving opening arranged opposite the first receiving opening and provided for receiving another wire,
- 25 - wherein another guiding means comprising a passage aligned with the second receiving opening is arranged in front of the second receiving opening, and
- wherein two guiding means are arranged at opposite ends of the receiving
30 space.

In another aspect of the present invention there is provided a holder for at least one connector for a cable comprising at least one wire, wherein the holder includes

- a body having at least one receiving space for receiving at least one connector having a first receiving opening for receiving a wire to be connected, and
- 5 - guiding means arranged in front of the body and comprising at least one guiding passage extending through the guiding means and aligned with the receiving space for guiding a wire inserted into the guiding passage towards the receiving space,
- wherein the at least one guiding passage comprises opposite distal and proximal ends, the proximal end facing towards and the distal end facing
10 away from the receiving space,
- wherein the proximal end has a cross section not larger than a cross section of the first receiving opening of the at least one connector to be located in the receiving space, and
- wherein the distal end has a cross section larger than the cross section of
15 the proximal end.

The connection article according to the present invention comprises a holder having at least one receiving space for receiving a connector for a wire. The connector has at least one (first) receiving opening for receiving the wire to be connected. Typically, such a connector comprises two receiving openings at e.g., opposite ends of the connector.
20 Such a connector typically has a tubular shape and comprises fastening members like e.g. fastening screws extending into the inner hollow space of the connector to engage the wires to be connected by clamping the wires to the connector.

In front of the receiving space and the first receiving opening of the connector arranged in the receiving space of the holder there is arranged a guiding means for guiding
25 a wire into the first receiving opening of the connector. The guiding means comprises at least one guiding passage extending through the guiding means and aligned with the first receiving opening of the at least one connector. The guiding passage comprises two opposite ends, namely a distal and a proximal end wherein the proximal end faces towards the first receiving opening of the at least one connector (e.g. the receiving space of the
30 holder) and the distal end faces away from the connector and, accordingly, receives the wire to be guided towards and into the connector. For this purpose the distal end of the guiding passage has a cross section which is larger than the cross section at the proximal

end of the guiding passage. According to the invention, the proximal end of the guiding means has a cross section which is not larger than the cross section of the first receiving opening of the at least one connector. This arrangement guarantees that the guiding passage and, in particular, the interface between the guiding passage and the connector is free of any shoulders, edges, or surfaces facing the distal opening of the guiding passage.

The guiding means and the relation between the cross sections at the distal and proximal ends of the guiding passage and the cross section of the receiving opening of the connector establish an insertion aid for the wire to be connected. This insertion aid is very helpful in particular in a multi-wire cable having rather rigid wires which typically are not aligned with the associated connectors but which are automatically exactly aligned with the connectors by means of the guiding passages of the guiding means arranged in front of the holder holding the individual connectors.

For electrically insulating the individual connectors in case of a holder comprising a plurality of connectors, the holder typically is made from an electrically insulating material. In an alternative embodiment, the holder can comprise also other materials and, in particular, electrically conductive materials if the individual connectors are arranged electrically insulated relative to the holder. For example, between the individual connectors and the holder there can be arranged an insulating material while the holder as such is made from an electrically conductive material.

In the present invention, a plurality of connectors can be arranged in a fixed relative arrangement at the holder. Accordingly, the holder also functions as a connector spacer keeping the individual connectors separated and insulated from each other.

According to the invention each connector of the connection article comprises first and second receiving openings which normally are opposite to each other for receiving two wires to be connected. In such an embodiment, according to the invention, typically one guiding means is arranged in front of each of the receiving openings, respectively.

In one embodiment of the present invention, the guiding passage of each guiding means is substantially conically shaped. Normally or generally the guiding passage at its inner wall along 360° of its peripheral extension tapers from the distal end to the proximal end. Also it is preferred that the inner surface of the guiding means substantially is even. As an alternative, the inner surface can comprise grooves or ridges extending longitudinally at the inner surface of the guiding means.

In another embodiment of the present invention, the holder holds a plurality of connectors, i.e. the holder is provided with a plurality of receiving spaces each receiving at least one connector wherein each guiding means comprises a plurality of guiding passages extending therethrough with each guiding passage aligned with a respective one of the first openings of the plurality of connectors. In such a connection article it is preferred to arrange the connectors equidistantly to a longitudinal axis of the holder. Such an arrangement is advantageous in that fastening means of the individual connectors are accessible from the outer side of the holder within a circumferential angle of not more than about 270° and, preferably, not more than about 180° . Namely, arranging the connectors in the holder in such a way is convenient for manipulating the connectors for fastening the cables in that the access to all the fastening means of all the connectors is given within an area around the holder extending over less than 360° so that there is no need to access fastening means e.g. from underneath the holder. Namely, as soon as the cables to be connected are inserted into the connectors, in particular in case of rigid cables it is not possible to turn the holder around so as to engage the fastening means at a lower portion of the outer side of the holder. Since the holder in this configuration i.e. with the wires inserted into the connectors, is difficult to rotate or turn around, it is the more important that none of the fastening means have to be manipulated from underneath the holder.

As mentioned above, typically the connection article is surrounded by a protective shell bridging the area between the outer jackets of two cables. For keeping a space around the holder between the holder and the protective shell it is preferred to provide the holder and/or each guiding means with outer spacer projections. These outer spacer projections allow for centering the connection article within the protective shell so that an encapsulant material (e.g., a two component resin made commercially available by 3M Company, St. Paul, Minnesota, USA under the trade name SCOTCHCAST) can be inserted into the protective shell for filling out the space between the connection article and the protective shell.

Typically, for safety reasons, power cables are provided with cable shields or screens arranged around the group of wires of the cable and surrounded by an outer insulating layer of the outer jacket of the cable. It is important that the cable shields of the two cables to be connected are also electrically connected. In one embodiment of the

present invention, the holder and/or each guiding means comprises or comprise at least one outer clamp for fixing the additional wire for connecting the cable shields.

In another aspect of the present invention there is provided a kit for connecting cables each comprising at least one wire, wherein the kit comprises

- 5
- a connection article according to at least one of the above-mentioned embodiments,
 - a protective shell for surrounding the connection article, and
 - an encapsulant material for filling out a space within the protective shell located around the connection article when arranged within the protective
- 10 shell.

In an alternative embodiment of the present invention, the kit comprises

- a holder according to at least one of the above-mentioned embodiments,
 - at least one connector for arranging within the holder,
 - a protective shell for surrounding the holder, and
- 15
- an encapsulant material for filling out a spacer within the protective shell located around the holder when arranged within the protective shell.

In both embodiments of the kit an encapsulant material is provided for filling out the space within the protective shell around the connection article. The encapsulant material typically is introduced through a hole in the protective shell. After having filled

20

out the space within the protective shell around the connection article, the hole in the protective shell is closed. The encapsulant material can be curable or non-curable and, in particular, can be a resin or gel or foam (preferably a non-open cell foam for preventing water from penetrating through the foam).

The connection article of the present invention can be provided with a body

25

forming the holder and the guiding means as one part or as separate elements. Accordingly, the holder and guiding means can be formed integral with each other. Typically, the holder and guiding means are made from plastics material in an injection moulding process. In such a process, the connector or the connectors can be inserted in the mould prior to forming the connection article. Typically, the holder and each guiding

30

means are separate elements which are fit together and assembled after forming the individual elements.

Brief Description of the Drawings

The present invention will be described in more detail referring to the drawings in which

- 5 Fig. 1 shows a protective shell for a connection article for connecting the individual wires of two power line cables,
- Fig. 2 is a perspective view of the connection article with the individual elements thereof assembled to each other,
- Fig. 3 is a perspective and exploded view of the connection article according to Fig. 2,
- 10 Fig. 4 is a cross sectional view taken along line IV-IV of Fig. 2,
- Fig. 5 is an end view of the connection article in direction of V of Fig. 2, and
- Fig. 6 is a partial cross sectional view through the connection article taken along line VI-VI of Fig. 2.

15 Description of a Preferred Embodiment

Fig. 1 shows a connection article 10 for connecting the individual wires 12,14 of two power line cables 16,18. The connection article 10 is arranged within an outer protective shell 20 having two opposite ends 22,24 surrounding the cables 16 and 18 and sealed thereto e.g. by a mastic material 25. The space 26 within the protective shell 20 around the connection article 10 as well as around the individual wires 12,14 is filled out with an encapsulant material such as resin. This material is filled into the protective shell 20 via an opening 28 closed by a lid 30.

20

The design and construction of the connection article 10 is shown in more detail in Figs. 2 to 5.

25 The individual elements and parts of the connection article 10 are shown in Figs. 2 and 3. The connection article 10 comprises a holder 32 and two wire insertion guiding elements 34,36 arranged at opposite sides of the holder 32. The holder 32 includes a body 38 having a longitudinal extension and comprising receiving spaces 40 for receiving substantially tubular electrical connectors 42. In this embodiment, the body 38 of the holder 32 includes five receiving spaces 40 with five connectors 42 arranged therein. Each connector 42 comprises an electrically conductive sleeve 44 with two fastening screws 46 for clamping the electric wires 12,14 inserted into receiving openings 48,50 of the

30

connectors 42 (see also Fig. 5).

In this embodiment the receiving spaces 40 are open towards the opposite ends 52,54 of the body 38 of the holder 32. Accordingly, the connectors 42 can be inserted into the receiving spaces 40 from one of the opposite ends 52,54. Moreover, the receiving spaces 40 are provided with slit-like openings 56 at the circumferential outer side of the body 38. In the assembled state when the connectors 42 are inserted into the receiving spaces 40, the fastening screws 46 extend through the slit-like openings 56 allowing access to the fastening screws 46 and, in particular, preventing the tubular connectors 42 from rotating within the receiving spaces 40 so that the fastening screws 46 maintain their position so as to allow access from the circumferential outer side of the holder 32 which in particular is helpful prior to tightening the screws 46 for connecting the wires.

As shown in Figs. 2 to 5, each guiding element 34,36 is provided with a plurality of guiding passages 58 identical in number to the receiving spaces 40 and, accordingly, connectors 42 of the body 38 of the holder 32. Each guiding passage 58 is provided with an inlet opening 60 and an outlet opening 62 (see also Fig. 5). The outlet opening 62 is arranged proximal to the receiving opening 48,50, respectively, of the connector 42 while the inlet opening 60 is located distal from the connector 42. Moreover, each guiding passage 58 is provided with a substantially conically shaped or tapered section 64 and a substantially cylindrical section 66. The tapered section 64 comprises the inlet opening 60 which has a cross section larger than that of the outlet opening 62 at which the substantially cylindrical section 66 of the guiding passage 58 is terminated. In this embodiment, the inner surface 68 of each guiding passage 58 is substantially even.

As shown in particular in Fig. 5, the cross section of the outlet opening 62 of each guiding passage 58 is smaller than the cross section at the receiving opening 48,50 of the connector 42. Generally, the cross section of the outlet opening 62 is not larger than the cross section of the receiving opening 48 or 50 of the connector 42. This design allows the wire 12,14 entering or inserting into the guiding passage 58 through its inlet opening 60 to be smoothly guided into the connector 42 since neither in the guiding passage 58 nor at its interface to the connector 42 there are inwardly protruding portions so that the guiding passage 58 and the receiving openings 48,50 of the connectors 42 are free of any obstacles or stops for the wire 12,14 to be connected.

The guiding elements 34,36 as well as the body 38 of the holder 32 are preferably

made from a plastics material. This kind of material allows sufficient bonding to the encapsulant material arranged around the connection article 10 within the protective shell 20 for sealing against humidity so as to prevent any humidity from entering the interface between the holder 32 and the encapsulating material. The plastics material of the body 38 also contributes to the electrical insulation of the individual connectors 42. As can be seen in particular from Fig. 3, the two guiding elements 34,36 are provided with protruding tabs 70,72 inserted at the opposite ends of a receiving channel 74 extending through the body 38 of the holder 32 along its longitudinal direction 75. Within the receiving channel 74 the two tabs 70,72 are snap-fit so as to hold the guiding elements 34,36 in place at the opposite ends 52,54 of the holder 32. Other technical solutions attaching the guiding elements 34, 36 to the holder 32 are possible like e.g. glueing, screwing.

As can be seen in particular from Fig. 4, the screws 46 of all the connectors 42 are accessible from an outer side of the body 38 of the holder 32 within a circumferential angle of less than 180°. This allows the holder 32 to be arranged and to be supported by a support in the position as shown in Fig. 4 in which access to all the screws 46 is given without turning the holder 32 around for accessing the screws 46 of the two lower most connectors 42.

Moreover, as shown in Figs. 2, 3, and 5, the sleeve 44 of each connector 42 is provided with an observation hole 76 arranged substantially in the middle of the connector 42 for inspecting and observing the wires 12,14 to be connected so as to be inserted properly in the respective connector 42.

As mentioned before, the whole connection article 10 is centered in the protective shell 20 and located spaced apart therefrom by means of several spacer projections 78 arranged around the two guiding elements 34,36. This allows for maintaining sufficient space all the way around the connection article 10 within the protective shell 20 so that this space can be filled out with the encapsulant material.

Also from Figs. 4 and 5 it can be seen that the connection article 10 further comprises clamping recesses 80 at the outer sides of the guiding elements 34,36 serving for clamping and holding an additional wire 82 for connecting protective metallic screens (not shown) of the cables 16,18.

In the illustrated embodiment of the connection article the guiding elements 34,36 and the holder 42 are shown and described as individual elements assembled to each other

for forming the connection article. It is to be noted that all these elements including the connectors can be insert-molded as one unitary piece or part thereof e.g. one of the guiding elements and the body of the holder are formed as one part.

5 Although the invention has been described and illustrated with reference to the specific illustrative embodiment thereof, it is not intended that the invention be limited to this illustrative embodiment. Those skilled in the art will recognize that variations and modifications can be made without departing from the true scope of the invention as defined by the claims that follow. It is therefore intended to include within the invention all such variations and modifications as fall within the scope of the appended claims and
10 equivalents thereof.

What is claimed is:

1. A connection article for a cable comprising at least one wire, the connection article comprising
- a holder,
 - 5 - at least one connector arranged in the holder and having a first receiving opening for receiving a wire to be connected, and
 - guiding means arranged in front of the first receiving opening of the at least one connector, the first receiving opening defining a cross section and the guiding means comprising at least one guiding pas- sage extending through the guiding means and aligned with the first receiving opening of the at least one connector for
10 guiding a wire into the first receiving opening of the connector,
 - wherein the at least one guiding passage comprises opposite distal and proximal ends, the proximal end facing towards and the distal end facing away from the first receiving opening of the at least one connector,
 - 15 - wherein the proximal end has a cross section not larger than the cross section of the first receiving opening of the at least one connector,
 - wherein the distal end has a cross section larger than the cross section of the proximal end, wherein the at least one connector comprises a second receiving opening arranged opposite the first receiving opening and provided for receiving
20 another wire, and
 - wherein another guiding means comprising a passage aligned with the second receiving opening is arranged in front of the second receiving opening.
- 25 2. The connection article according to claim 1, wherein a plurality of connectors insulated from each other are arranged in the holder and a plurality of guiding passages extend through the or each guiding means and wherein each guiding passage is aligned with a respective one of the first receiving openings of the plurality of connectors.
- 30

3. A holder for at least one connector for a cable comprising at least one wire, the holder comprising
- 5 - a body having at least one receiving space for receiving at least one connector having a first receiving opening for receiving a wire to be connected, and
 - guiding means arranged in front of the body and comprising at least one guiding passage extending through the guiding means and aligned with the receiving space for guiding a wire inserted into the guiding passage towards the receiving space,
 - 10 - wherein the at least one guiding passage comprises opposite distal and proximal ends, the proximal end facing towards and the distal end facing away from the receiving space,
 - wherein the proximal end has a cross section not larger than a cross section of the first receiving opening of the at least one connector to be located in
15 the receiving space,
 - wherein the distal end has a cross section larger than the cross section of the proximal end, and
 - wherein two guiding means are arranged at opposite ends of the receiving space.
 - 20
4. The connection article according to claim 1 or the holder according to claim 3, wherein the guiding passage is tapered from the distal end to the proximal end.
5. The connection article or the holder according to any one of claims 1 to 4, wherein
25 the guiding passage of each guiding means is substantially conically shaped.
6. The holder according to any one of claims 3 to 5, wherein the body comprises a plurality of receiving spaces and a plurality of guiding passages extend through each guiding means and wherein each passage is aligned with a respective one of
30 the receiving spaces.

7. The connection article according to claim 2 or the holder according to claim 6, wherein the connectors or receiving spaces are arranged equidistant to a longitudinal axis of the body.
- 5 8. The connection article or holder according to any of the preceding claims, wherein the holder or body and/or each guiding means comprises outer spacer projections for maintaining a position of the holder or body and each guiding means in a protective shell spaced apart from the protective shell.
- 10 9. A kit for connecting cables each comprising at least one wire, the kit comprising
- a connection article according to any one of claims 1-2, 4-5 or 7-8,
 - a protective shell for surrounding the connection article, and
 - an encapsulant material for filling out a space within the protective shell located around the connection article when arranged within the protective
- 15 shell.
10. A kit for connecting cables each comprising at least one wire, the kit comprising
- a holder according to any one of claims 3 to 8,
 - 20 - at least one connector for arranging within the holder,
 - a protective shell for surrounding the holder, and
 - an encapsulant material for filling out a spacer within the protective shell located around the holder when arranged within the protective shell.

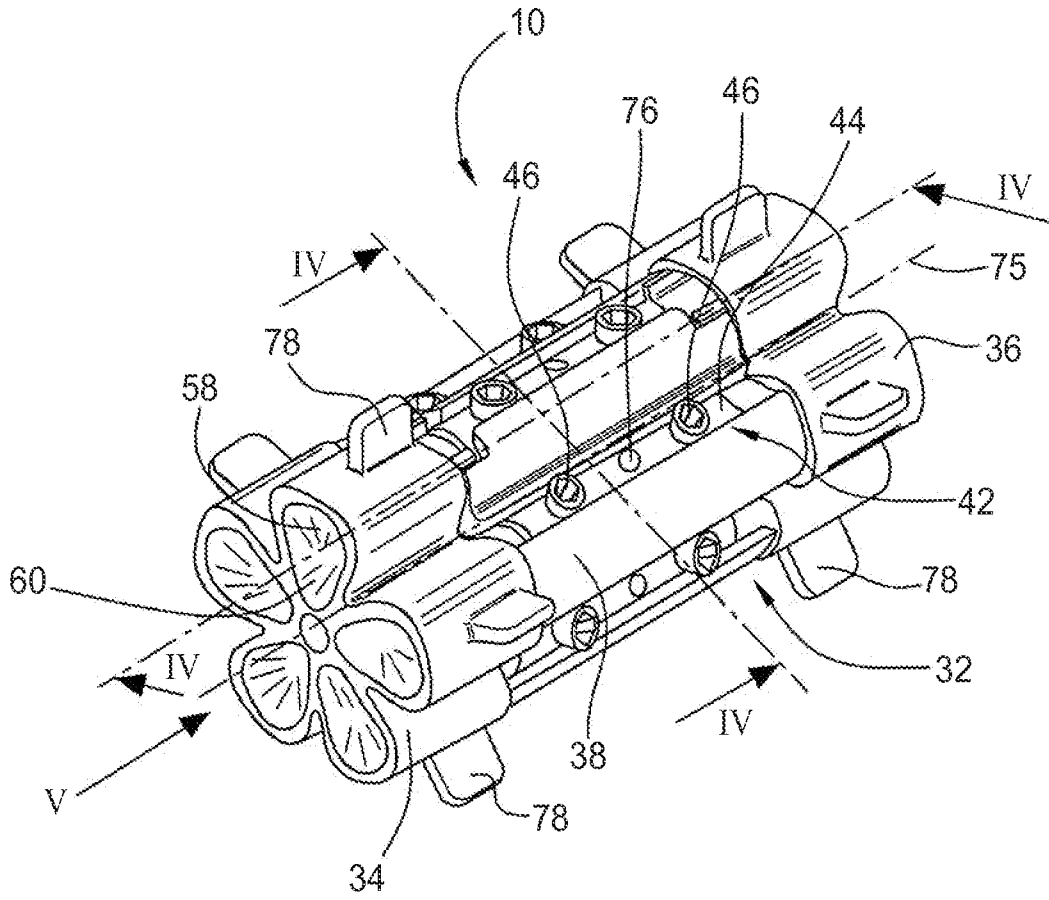

FIG. 2

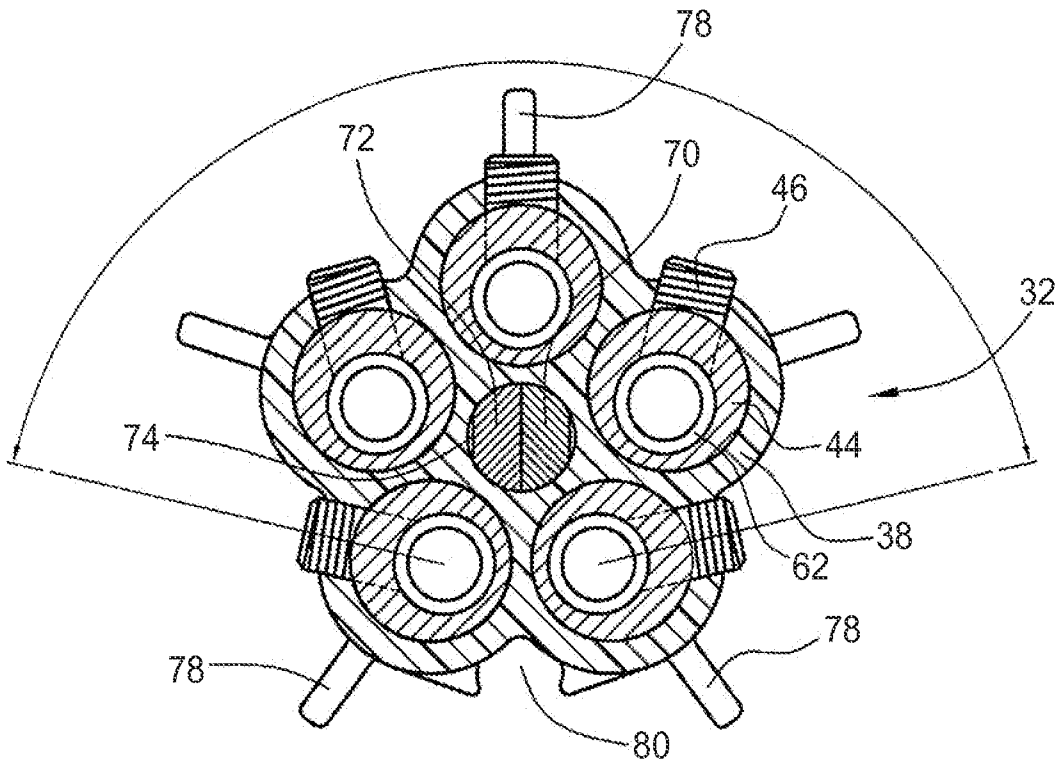

FIG. 4

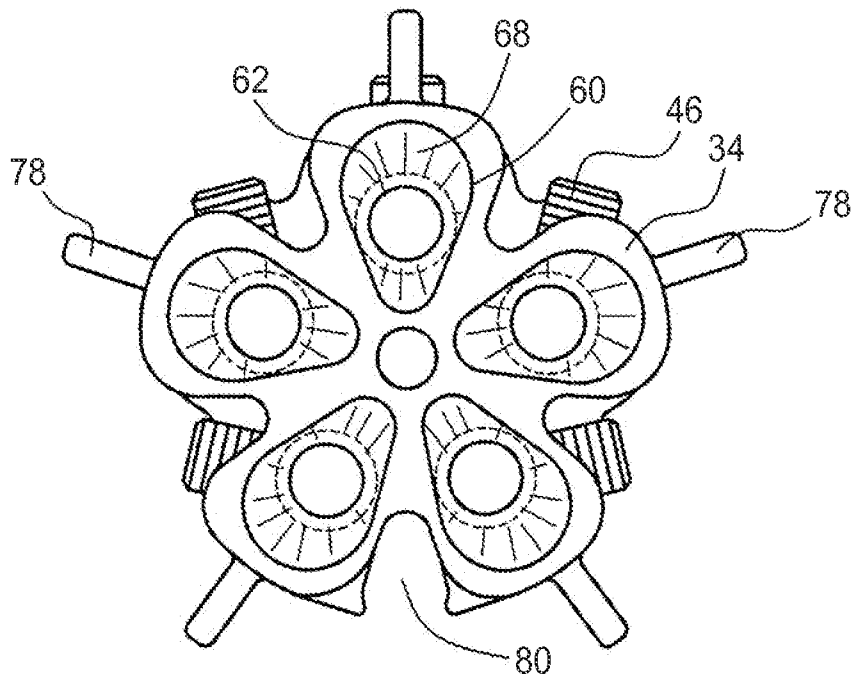

FIG. 5

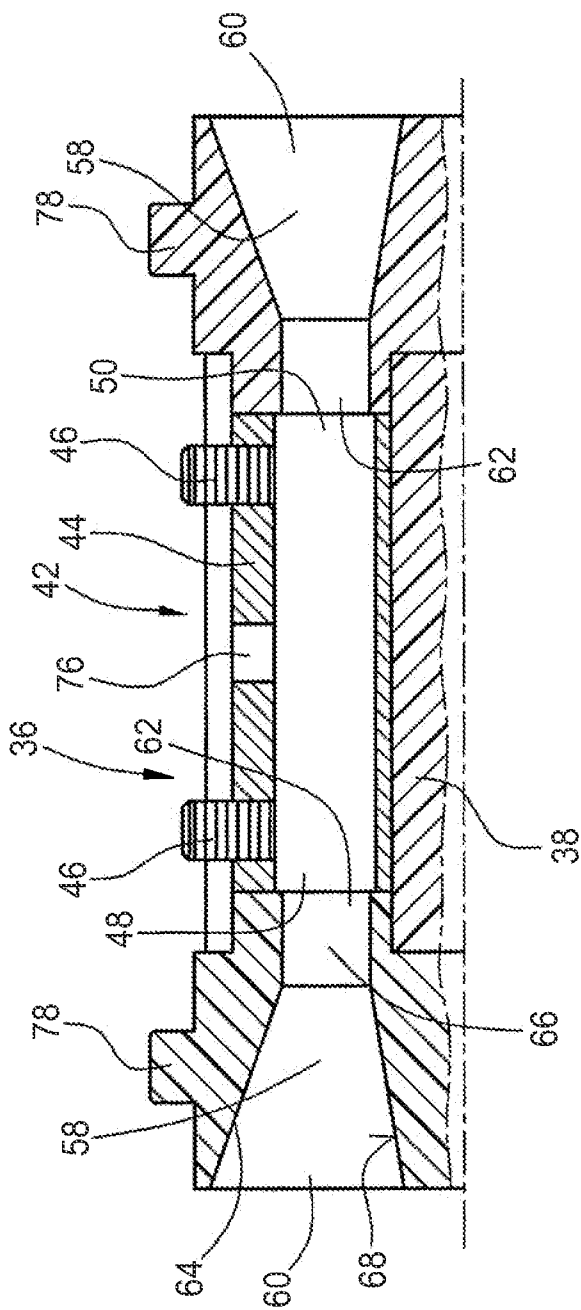

FIG. 6

INTERNATIONAL SEARCH REPORT

International application No.
PCT/US2007/085995**A. CLASSIFICATION OF SUBJECT MATTER****H01R 24/02(2006.01)i**

According to International Patent Classification (IPC) or to both national classification and IPC

B. FIELDS SEARCHED

Minimum documentation searched (classification system followed by classification symbols)

IPC 8: H01R H01H H05F H02H

Documentation searched other than minimum documentation to the extent that such documents are included in the fields searched

KOREAN Utility Models and applications for Utility Models since 1975

Japanese Utility Models and applications for Utility Models since 1975

Electronic data base consulted during the international search (name of data base and, where practicable, search terms used)

PAJ, FPD, USPAT, eKIPASS "CONNECTOR""ELECTRICAL""HOLDER""GUIDING"

C. DOCUMENTS CONSIDERED TO BE RELEVANT

Category*	Citation of document, with indication, where appropriate, of the relevant passages	Relevant to claim No.
A	JP 08149679A (TOKYO ELECTRIC POWER CO. INC, MITSUBISHI CABLE IND LTD.) 07 JUNE 1996 (1996-06-07) see the abstract, figures 1-6	1-4
A	US 5033982A (DEREK A. LUCAS) 23 JULY 1991 (1991-07-23) see the abstract, figures 1-5, column 2 line 5 - column 4 line 52	1-4
A	US 6383022 B1 (TAKAO MURAKAMI et al.) 07 MAY 2002 (2002-05-07) see the abstract, figures 1A-1B, column 2 line 61- column 3 line 20	1-4
A	US 5885104A (NIGEL STEWART FOSTER et al.) 23 MARCH 1999 (1999-03-23) see the abstract, figures 2-3, column 2 line 47 - column 3 line 5	1-4
A	EP 0924713A1 (SUMITOMO WIRING SYSTEMS, Ltd.) 23 JUNE 1999 (1999-06-23) see the abstract, figure 1, paragraphs [0013]-[0036]	1-4

 Further documents are listed in the continuation of Box C. See patent family annex.

* Special categories of cited documents:

"A" document defining the general state of the art which is not considered to be of particular relevance

"E" earlier application or patent but published on or after the international filing date

"L" document which may throw doubts on priority claim(s) or which is cited to establish the publication date of citation or other special reason (as specified)

"O" document referring to an oral disclosure, use, exhibition or other means

"P" document published prior to the international filing date but later than the priority date claimed

"T" later document published after the international filing date or priority date and not in conflict with the application but cited to understand the principle or theory underlying the invention

"X" document of particular relevance; the claimed invention cannot be considered novel or cannot be considered to involve an inventive step when the document is taken alone

"Y" document of particular relevance; the claimed invention cannot be considered to involve an inventive step when the document is combined with one or more other such documents, such combination being obvious to a person skilled in the art

"&" document member of the same patent family

Date of the actual completion of the international search

01 MAY 2008 (01.05.2008)

Date of mailing of the international search report

01 MAY 2008 (01.05.2008)

Name and mailing address of the ISA/KR

Korean Intellectual Property Office
Government Complex-Daejeon, 139 Seonsa-ro, Seo-gu, Daejeon 302-701, Republic of Korea

Facsimile No. 82-42-472-7140

Authorized officer

CHEKAL Hyun

Telephone No. 82-42-481-5667



INTERNATIONAL SEARCH REPORT

International application No.

PCT/US2007/085995

Box No. II Observations where certain claims were found unsearchable (Continuation of item 2 of first sheet)

This international search report has not been established in respect of certain claims under Article 17(2)(a) for the following reasons:

1. Claims Nos.:
because they relate to subject matter not required to be searched by this Authority, namely:

2. Claims Nos.:
because they relate to parts of the international application that do not comply with the prescribed requirements to such an extent that no meaningful international search can be carried out, specifically:

3. Claims Nos.: 5-10
because they are dependent claims and are not drafted in accordance with the second and third sentences of Rule 6.4(a).

Box No. III Observations where unity of invention is lacking (Continuation of item 3 of first sheet)

This International Searching Authority found multiple inventions in this international application, as follows:

1. As all required additional search fees were timely paid by the applicant, this international search report covers all searchable claims.
2. As all searchable claims could be searched without effort justifying an additional fee, this Authority did not invite payment of any additional fee.
3. As only some of the required additional search fees were timely paid by the applicant, this international search report covers only those claims for which fees were paid, specifically claims Nos.:

4. No required additional search fees were timely paid by the applicant. Consequently, this international search report is restricted to the invention first mentioned in the claims; it is covered by claims Nos.:

Remark on Protest

- The additional search fees were accompanied by the applicant's protest and, where applicable, the payment of a protest fee.
- The additional search fees were accompanied by the applicant's protest but the applicable protest fee was not paid within the time limit specified in the invitation.
- No protest accompanied the payment of additional search fees.

INTERNATIONAL SEARCH REPORT

Information on patent family members

International application No.

PCT/US2007/085995

Patent document cited in search report	Publication date	Patent family member(s)	Publication date
JP08149679A	07.06.1996	NONE	
US05033982A	23.07.1991	NONE	
US06383022B1	07.05.2002	DE60015014C0 DE60015014T2 EP01059698A2 EP01059698A3 EP01059698B1 EP1059698A2 EP1059698B1 EP1059698A3 EP1059698A2 EP1059698B1 EP1059698A3 EP1059698A2 JP12353567A US6383022BA	25.11.2004 31.03.2005 13.12.2000 07.11.2001 20.10.2004 13.12.2000 20.10.2004 07.11.2001 13.12.2000 07.11.2001 13.12.2000 19.12.2000 07.05.2002
US05885104A	23.03.1999	CN1104761C DE69807981C0 DE69807981T2 EP00881717A2 EP00881717B1 EP0881717A2 EP881717A2 EP881717A3 EP881717B1 JP10335009A JP2992689B2 US5885104A	02.04.2003 24.10.2002 20.02.2003 02.12.1998 18.09.2002 02.12.1998 02.12.1998 20.10.1999 18.09.2002 18.12.1998 20.12.1999 23.03.1999
EP00924713A1	23.06.1999	CN1220504A EP0924713A1 JP11238419A2 JP3551773B2 US6296240BA	23.06.1999 23.06.1999 31.08.1999 11.08.2004 02.10.2001