

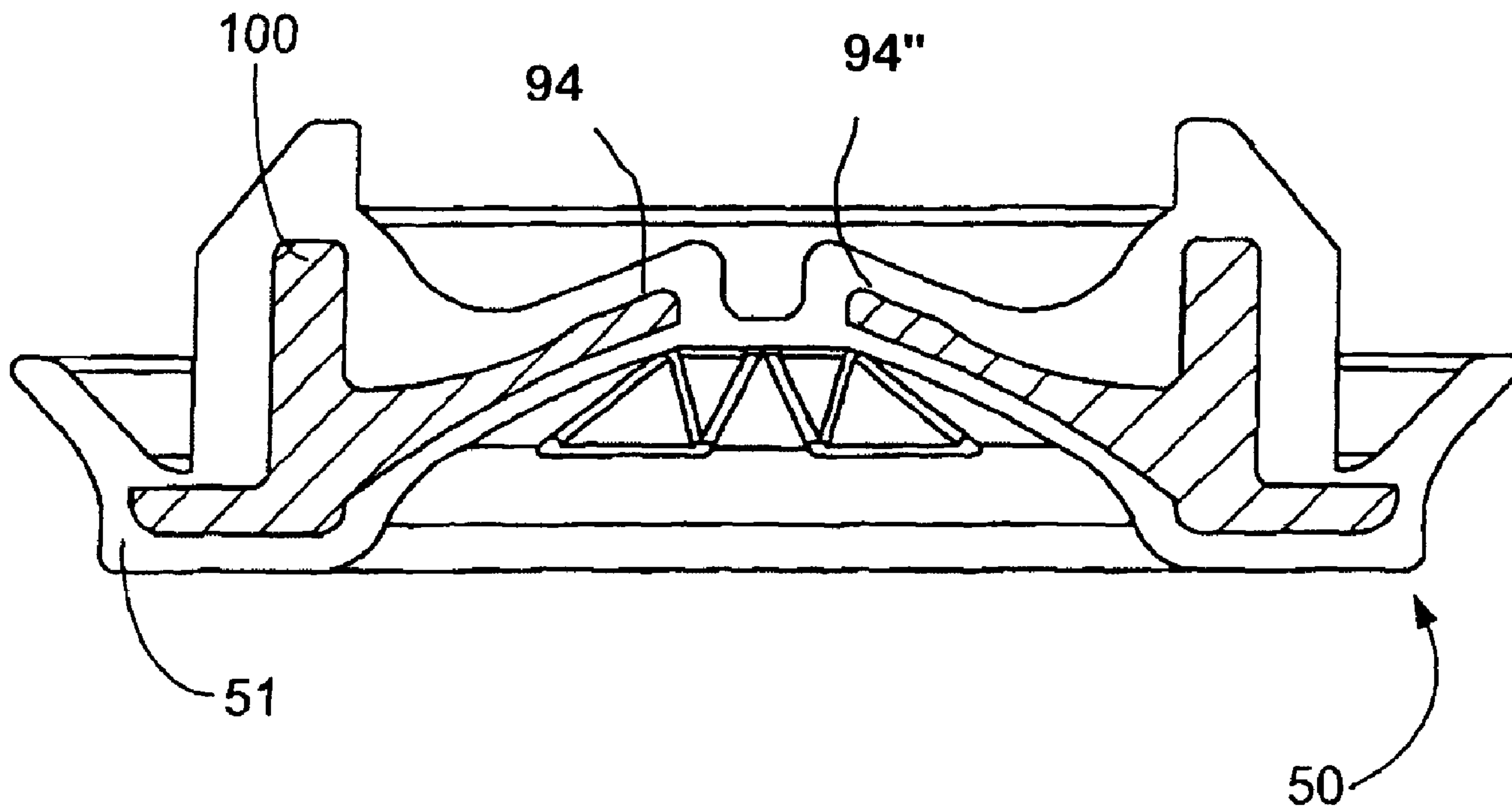

(22) Date de dépôt/Filing Date: 2006/07/20
 (41) Mise à la disp. pub./Open to Public Insp.: 2007/01/21
 (45) Date de délivrance/Issue Date: 2009/09/22
 (30) Priorité/Priority: 2005/07/21 (US60/701,415)

(51) Cl.Int./Int.Cl. *H02G 3/22* (2006.01),
H02G 3/02 (2006.01), *H02G 3/08* (2006.01),
H01R 13/58 (2006.01), *H01R 13/52* (2006.01)
 (72) Inventeurs/Inventors:
 PYRON, ROGER, US;
 YOSS, CRAIG, US
 (73) Propriétaire/Owner:
 THOMAS & BETTS INTERNATIONAL, INC., US
 (74) Agent: MACRAE & CO.

(54) Titre : RACCORD DE CORDON A BOUTON
 (54) Title: BUTTON STYLE CORD CONNECTOR



(57) Abrégé/Abstract:

This invention pertains to a cord connector that both seals and provides strain relief automatically upon wire insertion. The cord connector comprises a wire passageway through a pliable shell which seals around both the wire inserted through the passageway as well as the knock-out or wall opening into which the connector is secured. A more rigid skeleton supports this shell and is provided with appendages which permit the wire to pass through the passageway but which block or resist any removal of the wire from the passageway. Preferably the shell is overmolded over the skeleton for ease of manufacture.

ABSTRACT OF THE INVENTION:

[00103] This invention pertains to a cord connector that both seals and provides strain relief automatically upon wire insertion. The cord connector comprises a wire passageway through a pliable shell which seals around both the wire inserted through the passageway as well as the knock-out or wall opening into which the connector is secured. A more rigid skeleton supports this shell and is provided with appendages which permit the wire to pass through the passageway but which block or resist any removal of the wire from the passageway. Preferably the shell is overmolded over the skeleton for ease of manufacture.

BUTTON STYLE CORD CONNECTOR

[0001]

FIELD OF THE INVENTION:

[0002] This invention, in general, pertains to cord connectors for supporting electrical wire to a wall or a panel of an enclosure. More particularly, the present invention pertains to a connector for an electric cable providing both sealing and strain relief characteristics.

BACKGROUND OF THE INVENTION:

[0003] Liquid tight cord connectors are quite common for supporting electric wire passing through an aperture of an electrical enclosure or a wall. These cord connectors are often used to protect wires or tubes passing through such apertures against wear or shock or both.

[0004] Figures 1-7 of U.S. Pat. No. 2,458,409 discloses a connector member with integral spring-like fingers cooperating with and preventing axial movement of a cable member after it is inserted into the knockout hole through the connector member.

[0005] Figures 1-8 of U.S. Pat. No. 3,516,111 shows a bushing member having a plurality of flexible generally pie-shaped supports, each adapted to accept the placement of an element there between to yield in the direction of element positioned through the opening for resilient engagement with the element.

[0006] Figures 1-10 of U.S. Pat. No. 4,299,363 shows a connector formed from a resiliently flexible material with a plurality of jaws directed toward the axis center of the connector to resiliently seat against the inserted cable to oppose withdrawal of the cable from the connector.

[0007] Figure 2 of the U.S. Pat. No. 5,410,104 discloses a low profile connector compressible grommet for use in a connector having internally inclined surfaces with a plurality of ribs spaced about the periphery of a sleeve with spaces between the apexes.

[0008] These connectors are typically pushed or otherwise inserted into an opening in the enclosure such as a knock-out of an electrical outlet box or panel. Once the connector is in place, a wire or cable is then pushed through its center and into the enclosure for subsequent termination with an electrical device or fixture inside the box. The connector itself is generally configured with a plurality of inwardly extending fingers that engage and grip the wire and which permit the wire to be pushed into the box but which make it difficult to pull the wire back out of the box. Hence such connectors not only help isolate the wire from the sharp edges of the knock-out, but they also provide strain relief by transferring the wire withdrawal force to the enclosure itself rather than allowing such force to proceed to the terminated end of the wire and thus to the device to which the wire is connected.

[0009] Most such connectors are made of plastic as in the '363 patent, but metal connectors exist as well (see, for example, the '409 patent). Also, such connectors are generally of one piece construction, but multiple piece connectors have also been devised as shown in the above '104 patent.

[0010] However, although most such devices may be suitable at providing strain relief to the inserted wire, their construction, and particularly their flexible finger component, is such that they are unable to also seal around the wire and provide weather protection in order to prevent moisture from passing into the box. One exception to this is the '104 patent which both seals and provides strain relief. However, this patent seals via a grommet that is compressed between a connector body and a threaded end cap is provided as an extra part in the normal fashion. Hence, to effect a seal according to this patent, more than simply inserting the wire through the strain relief connector is required. Instead, the user must also assemble the grommet into the connector body located on one side of the enclosure and tighten the threaded end cap onto the connector body, this threaded end cap being on the other side of the enclosure.

[0011] Such ready access to both sides is not always possible due to the tight constraints and limited room in typical electrical enclosures. Furthermore, such assembly and installation steps increase the expense of using this connector. Additionally, the end cap itself is bulky and extends into the interior of the enclosure which may either interfere or cause interference with other devices therein. Also, the grommet size limits the range of wire gauges that can be used with this connector and still seal and seat properly.

DESCRIPTION OF THE RELATED ART:

[0012] A device which may provide weather protection, but has many other shortcomings is shown in Figure 1. Reference numeral **10** generally indicates a two-component (a skeleton with a flexible outer membrane) grommet **10** comprised of having a wide tubular sleeve wall (shown as **20** in Figure 4). The tubular sleeve wall **20** expands radially outwardly at either ends (shown as

22, 24 in Figure 4) into a top and a bottom circular extensions (12, 14) in an inverted umbrella-like manner and also expands radially inwardly at either ends into central portions (16, 18) to define a small aperture 18 in the center.

[0013] As can be seen in Figure 1 and Figure 2, the top circular extension 12 is divided by a circumferential ridge 22 into two portions, an inner middle section 24 and an outer peripheral section 26, where the outer peripheral section 26 has a smaller outer diameter 27 than the diameter 28 of the bottom circular extension 14. The perimeter of the surface of the outer peripheral section 26 of the top circular extension 12 is partly broken by a couple of tabs 30, and 30'. The surface of the inner middle section 24 is sloped downward toward the opposite side extension 14.

[0014] The surface of the bottom circular extension 14 is also sloped downward from a second ridge 23. The second ridge 23 divides the bottom circular extension 14 as well. As mentioned above, the outer peripheral portion 27' has a much larger outer diameter than the top circular extension diameter 28. The bottom ridge has an inner middle portion 25 that may be either flexed toward or away from the top circular extension 12.

[0015] Referring now to Figure 3, the inner skeleton portion 32 which includes the two tabs 30 and 30' is shown. As can be seen, the skeleton portion 32, which is substantially tubular along its base body 34, is overmolded with a rubber material described above. This skeleton portion 32 has an outer flange 36 on one end 38. Along the inner circumference 37 of this flange 36 are upright walls 35 that extend perpendicular to the flange 36 (i.e. extend parallel to the cable 48 as shown in Figure 6). At the distal ends 39 of these walls 35 remote from the flange 36 are inwardly directed pie-shaped fingers 33, 33', & 33'' that curve back towards the flange 36. The base body 34 is broken between the narrower portions 31, 31' which supports the two tabs and the

wider portions 41, 41' which support the pointed pie fingers 33, 33', & 33''. The flange 36 is also shown to have small holes 43 so that the rubber coated relief can be formed around the flange 36.

[0016] Referring now to Figure 4, a cross section view along the line A-A of Figure 3 is shown. The cross section view more clearly shows that the pie fingers 33, 33', & 33'' extend from the side wall 35 and are directed downwardly toward the flange 36. Because the pie fingers 33, 33', 33'' are curved outwardly at a distance away from the flange 36, the flange 36 itself does not retain the inserted cable with much force. In fact, due to the distance between the flange 36, and the base 39 of pie-shaped fingers 33, 33', 33'', over time, the cable retention force will be diminished considerably.

[0017] Further, the pie fingers 33, 33', 33'' extend from the wall's distal end 39. The pie fingers 33, 33', 33'' flex from their bases at the distal end 39 due in part to their wide width, thus resisting greater deflections or flexibility. This makes insertion and pullout for reuse very difficult as well. Further, because the pie fingers 33, 33', 33'' stem from the tubular body distal end 39, the fingers present difficulty in removal of an inserted cable. In use, once an extreme force is utilized to pull out the cable, the device, in effect, becomes very difficult to reuse and thus rendered useless. Also, the side wall 35 extends about even with the wall catches (circumferential ridge) 22. This all leads to the design thickness being bulkier, which could cause interference with other parts in the box.

[0018] Additionally, the tips or apex 44 of the pie fingers 33, 33', 33'' are quite spread away from each other and away from the center, leaving a large central gap 45. Due to this gap 45, and the size of the device itself, the design fits only within certain standard opening sizes. In fact, these devices are not manufactured for non-standard sizes. Further, due to the wide gap 45

as mentioned above, and the fact that the tips **44** of the design do not extend to the center, there is only a limited resistance to an inserted cable. Also, because of this gap **45**, only large size cables can engage fingers **33**, **33'** and **33''**. And thus, this design is useful for only a limited range of cable sizes. Hence, only when the cabling begins to flex will the fingers of the design provide pull-out resistance (it will, however, still seal the cable due to the stretching of the overmolded material). Thus, the type of cable cross-sectioned shape of cable and its gauge that can be used is limited for the device. Further, as can be seen in Figure 4, the thickness of each pie finger **33**, **33'**, **33''** stays constant throughout, so that the flexibility will mostly occur at the base portion.

[0019] The cross section view also shows that only the inner middle section **24** of the top and the inner middle portion **25** of the bottom are supported by the pie fingers **33**, **33'**, **33''** and the flange portions **36** of the skeleton portions. The outer top extensions **26** of the top portion and the bottom extension **27** of the bottom portion are not supported by the skeleton and are separated by a space region **11** reserved for both sides **46**, **47** of the wall **48** as shall be shown in FIG. 4 and in the following FIGS. 5 and 6.

[0020] As can be seen in Figure 4, the device has two central portions **16**, **18** of which the central portion **18** encompasses an open aperture characteristics. . Although the central portion **16** of the design is originally intact till pierced, the outside dome **14** of the device comes with a hole in it, its central portion **18**. Thus, it is only the inside depression that remains intact. In practice, moisture and debris can collect inside the device via this hole which is not desirable at all. Thus, the device can not be used as a plug due to the device having two walls.

[0021] As can be seen in Figure 5, the outer peripheral portion **27'** abuts the one side of the box with the walls extending out of the box. The cabling is then pushed through the device

from outside the box as seen in Figure 6. Because of the finger's position distanced away from the flange 36 and its angle, the cable insertion is made difficult according to the design. As can be seen in Figure 5, an installer presses the smaller top extension side 12 from the inner side 46 of the wall 48 to click and fix the grommet 10 into the wall aperture 49. As can be seen in Figure 6, once the grommet 10 is in place, the installer now needs to focus on the outer side 47 of the box to insert a cable 48 into the central portion 16.

[0022] Although the grommet 10 of the device may be weatherproof, because the cable is supported directly by only the two flexible outer extensions, and no rigid skeleton, the connector does not provide for stability. Further, as discussed above, the installer is forced to use two sides of a box or a wall (to install the grommet first, and then to install the cable on the other side). In tight spaces, or a wall where other side is not easily accessible, such installation can be frustrating.

SUMMARY OF THE INVENTION:

[0023] It will therefore be seen that the present invention provides a connector for non-metallic sheathed cable that is of one piece construction and adapted for ready application to a box outlet opening utilizing the snap fit connection that has been described and illustrated, without requiring any special tools to apply the connector to the box or cable to the connector. The connector is free of clamps and other similar types of mechanical connecting devices, and no clamp acting on the cable end is required within the box in which the cable end extends. A further embodiment of the invention provides a wire connector comprising a single unit thereby avoiding the situation where the installer must field assemble or tighten multiple components together in order to complete the installation.

[0024] One embodiment of the invention provides for a connector that readily accepts both oval and round non-metallic sheathed cables with equal facility, and permits a ready sliding action on the cable end into the box. Movement tendencies of the cable in the opposite direction are immediately halted by the collet like closing action of the connector jaws on the cable.

[0025] Yet a further embodiment of the invention is to provide a liquid-tight, strain-relief cord connector that also helps isolate and protect the wire from the sharp edges of the knock-out or opening through which the wire passes. Another embodiment of the present invention also provides a connector that not only provides strain relief, but also seals the perimeter around both the wire and the enclosure or knock-out opening through which the wire passes. The present invention also provides a connector where the strain relief and the sealing characteristics occur automatically upon wire insertion and do not require any secondary operation or installation step which would prolong the installation process.

[0026] Yet another embodiment of the invention provides a connector that is not bulky and does not project significantly from either side of the box so as to eliminate any chances of interference. Still another embodiment of the invention provides a connector that is sized slightly bigger than the opening into which it will fit. Another embodiment provides a connector that can accommodate a variety of different cord gauges without the need for the installer to keep different connector sizes in store.

[0027] A preferred embodiment of the present invention provides for very little gap center. As the tips or apex of the fingers extend closer to the center and to each other, there is very little gap between these tips and they form a tighter circle between them. A further preferred embodiment of the present invention provides for easier cable insertion by having the fingers

angle away from the flange. Yet another preferred embodiment of the invention provides for higher cable retention force, because the fingers are curved inwardly, not outwardly, and cable pull-out is resisted better by the design of the preferred embodiment.

[0028] A preferred embodiment of the present invention provides for fingers which flexes at its mid-region and not at its base or at its tip with fingers extending from a mid-region of the wall, or from the region of the wall closest to the flange, not from the wall's distal end. Further, a preferring embodiment is provided wherein a mid-region of each finger is slightly reduced in thickness or each finger is perforated so that the finger will flex at a mid-region and not at its base.

[0029] A preferred embodiment provides for utilization with non-standard opening. In other words, a typical 3/4 inch fitting actually requires a larger diameter knockout. Same with a typical 1/2" fitting, it requires a larger than 1/2" hole. However, with the present invention, the operator does not need to drill a larger hole, but instead, can actually drill a 3/4 inch opening for a 3/4 inch fitting. Another preferred embodiment is provided that has a lower profile where the invention fingers extend inwardly from a mid-region of the wall. Also, according to the invention, the wall does not extend as much as the wall catches do.

[0030] Additionally, a preferred embodiment that is reusable is provided by the present invention. Despite the higher cable retention properties of the invention, the invention seal can be removed from the cable and hence are re-usable (such as when a new cable is to be pushed through the box opening). Specifically, according to the present invention, to remove the invention device, a user would skew or pivot it on the cable so that it projects outward from the cable at a 45 or less degree angle rather than at its normal 90 degrees. This will cause the fingers to be mis-aligned with each other and hence enable the embodiment to be slid off the cable.

[0031] A preferred embodiment of the invention is provided where the product can be used as both a cable fitting as well as a plug. When used as a fitting, the cable will extend through device into the box. However, when the product has not yet been pierced by cabling, its seal remains intact and hence can be used as a plug to seal an unused opening. While the prior art design is also originally intact till pierced, one side of the device comes with a hole in it. Only one particular side of the depressions remains intact. Thus, moisture and debris can collect inside the prior art device via this hole which is not desirable at all. This is also due to the present invention having only a single wall whereas the prior art device has two walls.

[0032] A preferred embodiment of the invention is provided wherein the embodiment can have a broader cable range usage. The invention can be used for both thick power cabling as well as thin data cabling. This is because according to the invention, the tip or apex of each finger extends nearly to the very center of the fitting. There is only a tiny center circle made of the over-molded material that is removed from the invention when a cable is pushed through. Hence, any cable larger than this over-molded center will cause the perimeter of this opening to stretch around the wire as well as cause the fingers to flex. In contrast, the tips of the prior art design do not extend nearly to the center. Hence, for the prior design, the flexing of the fingers will be triggered only when a cabling of a particular size that is thick enough is inserted. Thus, only a particular cabling of certain thickness will begin to trigger the flexing of the fingers which in turn will provide pull-out resistance (the prior art device, however, may still seal the cable due to the stretching of the over-molded material, but not effectively provide pull-out resistance).

[0033] Such inventive features could be provided in a preferred embodiment of a cord connector consisting of a pliable shell having a wire passageway therethrough. Adjoining this

shell is a more rigid skeleton also configured with a wire passageway therethrough. This skeleton incorporates deflectable appendages which are deflected by the passage of a wire through the wire passageway. Further, these deflectable appendages restrict the removal of the wire back through the wire passageway in the opposite direction, whereby the pliable shell seals around the wire in the wire passageway while the skeleton provides strain relief to the wire in the wire passageway.

[0034] These and other advantages of this invention will become apparent from the following detailed description, which, taken in conjunction with the annexed drawings, discloses the preferred embodiment of the invention.

BRIEF DESCRIPTION OF THE DRAWINGS:

[0035] The invention will be more fully understood from the following detailed description taken in conjunction with the accompanying drawings which form a part of this application, wherein like numerals referred to like parts and in which:

[0036] Figure 1 is a top perspective view of a prior art device;

[0037] Figure 2 is a perspective view showing the opposite side of the device as shown in Figure 1;

[0038] Figure 3 is a top perspective view showing only the inner skeleton of the device as shown in Figure 1;

[0039] Figure 4 is a sectional view of the device as shown in Figure 1 along the A-A plane;

[0040] Figure 5 is a graphical illustration showing an initial step in installation of the prior art device as shown in Figure 1;

- [0041] Figure 6 is a graphical illustration showing the following step after the step shown in Figure 5 in installing the prior art device shown in Figure 1;
- [0042] Figure 7 is a perspective view of the completed assembly of the preferred embodiment as shown in Figure 7;
- [0043] Figure 8 is a perspective view showing the opposite side of the view shown in Figure 7A of the completed assembly;
- [0044] Figure 8A is a cross-sectional view of the embodiment shown in Figure 7 with the view taken along lines B-B of Fig. 7;
- [0045] Figure 8B is a cross-sectional view of the embodiment shown in Figure 8 with the view taken along lines E-E of Fig. 8;
- [0046] Figure 9 is a perspective view of the exposed skeleton of the preferred embodiment of Figure 7 with the overmold removed.
- [0047] Figure 10 is a top plan view of the exposed skeleton of Figure 9 of the present invention;
- [0048] Figure 11 is a side plan view of the exposed skeleton of Figure 9 of the present invention;
- [0049] Figure 12 is a cross sectional view of the exposed skeleton of Figure 9 taken along the lines C-C of Figure 9;
- [0050] Figure 13 is a graphical illustration showing the first step of the present invention embodiment being installed;
- [0051] Figure 14 is a graphical illustration showing the next step of installing the present invention embodiment;

[0052] Figure 15 is a plan view of the completed assembly of a preferred embodiment with a wire extending therethrough;

[0053] Figure 16 is a top view of another embodiment of the present invention;

[0054] Figure 17 is a cross sectional view of the embodiment shown in Figure 16 taken along the lines D-D of Figure 16;

[0055] Figure 18 is a perspective view of further another embodiment of the present invention;

[0056] Figure 19 is a top plan view of the embodiment as shown in Figure 18; and

[0057] Figure 20 is a cross sectional view of the embodiment shown in Figure 19 taken along the lines F-F of Figure 19.

DETAILED DESCRIPTION OF THE PREFERRED EMBODIMENT:

[0058] As can be seen initially in Figures 13, 14 and 15, reference numeral **50** generally indicates a preferred embodiment of the invention, that is shown applied to a wall **52** of a box **54** (of which only the indicated portion of wall **52** is shown), and specifically within the knock-out opening **56** that is formed in the box. The connector **50** is pushed into the knock-out or opening **56** from one side through an opening in wall **52** in the normal fashion. In essence, the connector **50** sandwiches the perimeter **57** of the knock-out opening **56** in the wall **52** between a pair of tabs **60, 60'** on one side and a rubber-coated flange **90** (over-molded by the elastomeric circumferential **84** as shown) on the other, thus imparting more force on either sides of the wall **52** than force imparted by the pliable shell. Flange **90** acts as a stop measure, preventing connector **50** from being pushed completely through the wall opening **56**. The outer surface of tab **60** is inclined to

ease its insertion through the opening 56. In essence, connector 50 helps isolate wire 58 from the sharp edges of the perimeter 57 of the knock-out opening 56, thereby preventing the wire's insulation from being scraped off or otherwise removed during wire insertion and/or pulling while maintaining an inner box environment that is contaminant free.

[0059] Referring to Figure 15, after the insertion of a cable, there is shown a button style cord connector 50 in place within the knock-out 56 in the wall 52 of an enclosure 54. Such enclosure 54 may be a typical electrical outlet box 54 or a load center. As can be seen, the wire or cord 58 extends through connector 50 positioned within the knock-out 56 in the typical fashion. Wire 58 is preferably a non-metallic sheathed cable but other cables are equally suitable for use with connector 50.

[0060] A wire passageway or a thin membrane position 98 may be present on the center of connector 50. While the figures 13 and 14 show this passageway 98 as being centrally located, that need not necessarily be the case. Passageway position, when configured with an aperture, 98 is intentionally sized to be slightly smaller than the smallest wire 58 that is to extend therethrough. Passageway 98 is thus configured to expand in size so as to fit tightly against whatever size, type or gauge wire 58 may pass therethrough.

[0061] According to Figure 13, the knock-out opening 56 is shown formed in a molded box 54 and this may be done with plastic, metal, sheetrock, or any other suitable materials in any manner usual and customary for a molded box or a wall with knock-out openings 56. While the box 54 may be of the molded plastic type, the invention is equally applicable to non-molded metal boxes, and specifically to the outlet openings of metal boxes as formed in any usual and customary manner for metal boxes.

[0062] Referring now to Figure 7, connector **50** is shown as consisting of two separate components, an outer shell body **51** and an inner skeleton portion **100** as shown in Figure 9. The outer shell body **51** is made of a pliable elastomer that can stretch under a load. This shell body **51**, and hence its undersized wire passageway position **98**, thus expand around any wire **58** pushed therethrough. Because shell body **51** is constructed of a pliable material, it automatically seals around such wire **58** as it is expanded, thereby preventing moisture from passing along wire **58** and into the interior of the enclosure or box. Also, because of such stretchability or flexibility of shell body **51**, a variety of different wire sizes can be accommodated by a single connector **50**, there being no need to keep numerous connectors on hand depending on the wire gauge employed. Further, the pliability of shell body **51** not only helps connector **50** seal around wire **58**, but such flexibility also enables connector **50** to seal around the opening or knock-out **56** in wall **52**. Thus, connector **50** and more particularly shell body **51** provides a liquid-tight seal around both wire **58** and the knock-out in wall **52**.

[0063] The connector **50** specifically comprises a substantially circular body **64** of segmented relation, having an inverted mushroom-shape with a top circular side **70** of a particular diameter **74** and a curvilinear surface. The body **64** also includes a bottom frusto-conic surfaced side **80** with a larger diameter **82**. The curvilinear surface **66** of the top side **70** includes an upper circumferential ridge **72** from which the outer surface **73** slopes downward a short distance toward the outer perimeter **74**. From the outer perimeter **74**, a side stem wall **78** is provided which is parallel to the central axis **91**.

[0064] The inner middle surface **71** of the top circular side **70** also slopes downward but in a slightly curvilinear manner toward the passageway position or the center aperture location **98**.

The center aperture location **98** may be provided with a ready-made small hole or it may also be formed with a thin elastomer membrane for a cable tip **59** to bore through with minimal resistance.

[0065] Starting from the upper ridge **72** of top side **70**, the inner surface **71** is further defined by a set of opposed jaws **62** projecting inwardly toward the center location **98**, wherein each jaw is separated from each other jaw by a slit **75**, which may be covered by thin elastomeric membrane.

[0066] The set of jaws **62** are arranged concentrically about the central axis **91** of the body **64** and each comprises a collet finger **66** including a base **67** and a jaw head **68** to form a self acting collet **69** for receiving the end **59** of the non-metallic sheathed cable **58** that is to be applied to the box **54**, and hold same against withdrawal from the box **54**, as will be described hereinafter.

[0067] The outer perimeter **74** are formed to define curvilinearly contoured surfaces for cooperation with the box wall margin **57** in applying the connector to the box outlet opening **56**, as will be described hereinafter.

[0068] The circumferential periphery **73** of the upper ridge **72** is interrupted by a pair of opposed triangular wedge-shaped tabs **60, 60'**. Each tab **60, 60'** may include a gap interval **63** between either ends **77', 77'** for ease of molding during manufacturing process. Each tab **60, 60'** is over-molded on the bottom by a unitary column of abutting stem wall **61**. Both the tab **60** and the abutting stem wall **61** delineate from the upper ridge **72** and rest of the stem wall **78** to allow separate flexible movement of the tab **60, 60'** when being inserted into the opening **56** while the outer perimeter **74** remains constant.

[0069] Referring now to FIG. 8, the bottom frusto-conic surfaced side **80** is shown. The side **80** of the shell **51** is of plain annular configuration and faces away from the set of jaws **62**. Similar to the top circular side **70**, the bottom frusto-conic surfaced side **80** also includes a lower circumferential ledge **84** defining a berm-like shoulder shape with an outer sloped surface **87** extending downward a short distance toward the outmost perimeter **82**. The interior sloped surface **86** slopes in a curvilinear manner toward the opposite side of the center aperture location **90**, namely the cable ingress passageway position **98**.

[0070] The outermost perimeter **82** of the bottom frusto-conic surfaced side **80** and the outer perimeter **74** of the top circular side **70** together define a seat **76** (Seen in Figure 8A and 9) in between which the box wall rim portion **57** that defines the outlet opening **56** is received to mount the connector **50** in the box **54**, and specifically in its outlet opening **56**.

[0071] The ring shaped shell body **51** and the set of tabs **60** are integrally connected; the device **50** is thus of an integrated construction and is preferably formed, although not limited to, from a suitable material of the polymeric type such as elastomer, rubber, plastic, nylon or the like. A preferred material is one that provides the desired resilient flexibility, self-lubricating and dielectric qualities, and corrosion resistant and non-metallic nature that are preferred for practicing the invention.

[0072] While shell body **51** provides wire sealing or liquid-tight capabilities, its flexibility alone may not be sufficient at also providing direct strain relief characteristics as pointed out with the prior art reference discussed above. Thus, as can be seen in the cross-sectional views, Figures 8A and 8B, skeleton **100** is employed within the shell body **51** to impart stiffness and rigidity to connector **50**. Normally, the shell body **51** would be overmolded onto the skeleton **100** but other

methods of manufacture are equally possible. Because flexible shell body **51** and more rigid skeleton **100** may be formed or molded together, they act in tandem as a single unit for the user to handle, even though these different components provide different functions to connector **50**. Due to such over-molding, it may occur that these two components are fused or molded into a single integral unit, but this need not be the case as connector **50** will function just the same if these two components remain separate and operate independently after being combined together.

[0073] Now referring to Figure 9, the skeleton portion **100** will be described. The skeleton portion **100** is made of semi-rigid to rigid material and extends across nearly the full diameter of shell body **51**. Such skeleton portion **100** is shown as being arch-shaped so as to provide support and impart a domed or button shape to shell body **51**. Other shapes for skeleton portion **100** are equally likely, such as flat or even slightly concave. By its construction, skeleton portion **100** transfers any wire withdrawal force from wire **58** itself through skeleton portion **100** and to wall **52**. This force transfer helps retain connector **50** within the knock-out or wall opening **56** by compressing wall **52** even more so via tab **60** and flange **90**. Such withdrawal force transfer to wall **52** helps protect the device within the enclosure **54** to which wire **58** is attached.

Connector **50** also helps prevent wire **58** from being scraped or pulled along the edges of the knock-out.

[0074] Structurally, the skeleton portion **100** is generally a ring shape apparatus having a set of short distanced upright side walls **92**. The side walls **92** are characterized by a bottom end **93** and a top end **95** and the walls **92** extend almost fully around in a circumferential manner except at the two disjointed sections of tab supporting walls **96** and **96'**. Adjacent to the top end **95**, and supported by the tab supporting walls **96** and **96'**, are two tabs **60** and **60'**. Furthermore,

the bottom end 93 has an outwardly directed flange 90 situated along most of its perimeter.

Geometrically, the upright walls 92 adjoin the flange 90 at its inner circumference and the upright walls 92 extend perpendicular to the flange 90. The body side of the flange 90 defines segmented abutment surfacing 102 thereabout that forms part of seat that abuts against the outside surface of the box wall 52 when the connector 50 is applied to the box 54. The periphery of flange 90 include several apertures 77 to assist in integrating the over-molded elastomeric structure over the skeleton portion 100.

[0075] Figures 9 and 10 illustrate an inner finger type design for the above-mentioned collet function with this finger design incorporating a plurality of fingers or inwardly jutting pronged cable supports 94, 94', 94'', and 94''' having tips or apex 99 of deflectable appendages bordering wire passageway 101. In essence, at the interior side 97 of the side wall 92, at or near the bottom end 93 are four inwardly directed fingers 94, 94', 94'', and 94''' curved upwardly away from the flange 90. Because the fingers 94, 94', 94'', and 94''' are angled towards the inside of the box 54 (i.e. in the direction of cable travel) this makes it easier to push the cable through. Also, because the fingers 94, 94', 94'', and 94''' are curved inwardly, not outwardly, cable pull-out is resisted better by the design.

[0076] Also, these fingers 94, 94', 94'', and 94''' extend from a mid-region of the side wall 92, or from the region of the wall closest to the flange 90, not from the wall's distal top end. Because the fingers extend inwardly from a mid-region of the wall 92, and the wall does not extend as much as the wall catches do, this configuration leads to the connector device 50 having a low profile. Additionally, the tips or apex 99 of the fingers 94, 94', 94'', and 94''' extend closer to the center and to each other, there being very little gap 101 between these tips. Therefore, the tips 99 form a tighter circle between them. Further, a mid-region of each finger 94,

94', 94'', and 94''' is slightly reduced in thickness (as can be readily seen in Figure 8B) and/or each finger is perforated with perforations 89 (as can be seen in Figures 9 and 10) so that the fingers 94, 94', 94'', and 94''' will flex at a mid-region and not at its base. As a result, the jaws 62 flex from a mid-region, not from their base, this being accomplished via the reduced thickness or perforations of the mid-region of the fingers as mentioned above.

[0077] These fingers 94, 94', 94'', and 94''' and more particularly distal ends 99 are deflected when wire 58 is pushed through passageway 101. Distal ends 99 have a more pin-point interaction with wire 58 than curved edges above, but nevertheless, fingers 94, 94', 94'', and 94''' likewise become wedged against the outside of wire 58 when an attempt is made to pull wire 58 back out of connector 50. The gap or the circular spacing 101 between fingers 94, 94', 94'', and 94''' permit them to flex as needed. These fingers 94, 94', 94'', and 94''' also apply what might be said to be a direct linear force to wire 58 with such force also having an axial component thereto. As indicated above with respect to the vortex design, the act of inserting wire 58 within passageway 101, and particularly any attempted removal therefrom, causes greater holding power of connector 50 within wall 52 as well as strain relief properties for wire 58.

[0078] As can be seen, no gland nut or locknut is required to secure and seal wire 58 within wall 52 via button connector 50. Also, the sealing around the wire 58, the greater holding power of the connector within wall 52 and the strain relief for the wire all occur automatically upon the insertion of wire 58 into and through passageway 101. Furthermore, the initial insertion of connector 50 within wall 52 further creates a seal around the enclosure opening 56. Connector 50 also permits quick and easy installation and it does not have any components that require field assembly or which project excessively from either side of wall 52. Instead, connector 50 is just

slightly larger than the opening **56** itself. Further, while connector **50** comprises an outer shell **64** and an inner skeleton **100**, their assembly occurs at the factory and not in the field. Hence a single assembled unit **50** is employed by the installer who simply snaps connector **50** into an opening in wall **52**. No tools are required to install connector **50** which also greatly simplifies this process. The body **64** is formed with a plurality of over-molded marginal slots **75**, with the respective slots **75** and their thin elastomer membrane, extending substantially perpendicular to the axis **91** of the connector **50**, longitudinally thereof, and each slot **75** being centered on the respective jaws **62** (see Figure 7). Slots **75** are of sufficient depth, radially of axis **91**, to subdivide jaws **62** of the body **64** into segments for flexibility and extend substantially into jaw heads **68**.

[0079] Despite the higher cable retention properties of the current invention, the seal can be removed from the cable and hence are re-usable (such as when a new cable is to be pushed through the box opening). To remove the connector **50** that is already installed, the user would skew or pivot it on the cable **58** so that it projects outward from the cable **58** at a 45° or less degree angle rather than at its normal 90°. This will cause the fingers **94**, **94'**, **94''**, and **94'''** to be mis-aligned with each other and hence enable the connector **50** to be slid off the cable **58**.

[0080] Returning to the skeleton portion **100**, the fingers **94**, **94'**, **94''**, and **94'''** are separated by cross spaces **104**, which thus define the sides of the respective fingers **94**, **94'**, **94''**, and **94'''**. While the fingers **94**, **94'**, **94''**, and **94'''** are subdivided by the respective slots **75** when over-molded, the resulting jaws **62** are integral with the body segments **64** adjacent same, so that connector **50** is of one piece construction. However, the resiliently flexible nature of the material from which connector **50** is made accommodates flexing of body segments **64** radially of axis , which facilitates the snap fitting of the connector to the box, and permits the connector **50** to be

applicable to a wide range of knock-out tolerances. In other words, with the design of the invention, the opening **56** to be made in the box **54** can be a non-standard opening. A typical 3/4 inch fitting actually requires a larger diameter knockout **56**. Same with a typical 1/2" fitting, it requires a larger than 1/2" hole **56**. Thus, with the current invention, the installer can actually drill a 3/4 inch opening **56** for a 3/4 inch fitting.

[0081] Further, the connector **50** can be used as both a cable fitting as well as a plug. When used as a fitting, the cable **58** will extend through the connector **50** into the box. However, when the connector **50** has not yet been pierced by cabling, its seal (thin elastomer or similar membrane) remains intact and hence can be used as a plug to seal an unused opening **56**. While the design according to the current state of art is also originally intact till pierced, please note that the dome of the device according to the current state of art comes with a hole in it. Only the one particular side depression remains intact. Thus, moisture and debris can collect inside the device via this hole which is not desirable at all. This inventive feature of the present invention is also due to the connector **50** having a configuration of only a single wall whereas the device according to the current state of art requires two walls.

[0082] The connector **50** according to the present invention has a much broader cable range than the device of current state of art. The connector **50** can be used for both thick power cabling and thin data cabling as well as any other profile cabling such as a flat cross-sectional cabling. This is because in the connector **50**, the tip or apex **99** of each finger **94**, **94'**, **94''**, and **94'''** extends nearly to the very center of the fitting **101**. There is only a tiny center circle **101** made of the over-molded material that is removed from the connector **50**. Hence, any cable larger than this overmolded center will cause the perimeter of this opening to stretch around the wire **58**

as well as cause the fingers 94, 94', 94'', and 94''' to flex. In contrast, the tips of the design of the current state of art do not extend to the center (see Figure 3) and hence, only until the cabling can begin to flex the fingers 94, 94', 94'', and 94''' will the design provide pull-out resistance (requiring a cable of at least a certain thickness to reach the fingers).

[0083] While the above is described with respect to skeleton 100 being internal said shell 64, connector 50 could also be constructed with skeleton 100 being external to said shell 64.

[0084] Figures 16-20 illustrate the feature of the invention that various configurations of skeleton 100' with other shapes are equally possible. In each of them, skeleton 100' is configured with a central wire passageway 101 therethrough which aligns with that in shell body 64'. In some instances, tabs 62' and flange 90' form a part of skeleton 100' while in others, they form a part of shell 64'. Also, skeleton 100' is configured with a deflectable surface 85 which engages and mechanically secures the wire 58 in passageway 98'. This surface 85 also prevents such wire 58 from being pull back out through passageway 98'.

[0085] Figures 16 and 17 illustrate a vortex type design for surface 85 with this vortex design incorporating two flexible flaps 83 bordering wire passageway 98'. Curved edges 79 are located along the border of wire passageway 98' and are designed to surround at least a portion of the perimeter of wire 58. These flaps 83 and curved edges 79 are deflected by the act of pushing wire 58 through passageway 98', such wire 58 expanding or enlarging the size of wire passageway 98'. Hence, flaps 83 and curved edges 79 become wedged or compress against such wire 58 when it is pulled back in the opposite direction. Slits 81 aid in the deflection of flaps 83 thereby allowing them to grip wire 58 in such a manner. Flaps 83 impart what might be said to be both a radially inward force to wire 58 as well as an axial force. Also, any attempted removal of wire 58

from connector **50** is resisted by now-deflected flaps **83** which would then be moved in compression. These flaps **83** transfer such withdrawal force to wall **52** thereby increasing even further the engagement of wall **52** with connector **50** as well as providing strain relief for wire **58**.

[0086] Figures 18 to 20 discloses a further embodiment of the connector **50**'' invention with a circular shell body **64**'' and a set of tabs **62**'' and flange **90**''. This particular embodiment has been provided with an opening **98**'' and is double walled in contrast to the other embodiments discussed previously.

[0087] Having described the structure of different embodiments, the inventive method of utilizing a particular embodiment shall now be described with respect to Figures 13-15. As can be seen in Figure 13, the connector **50** is applied to a box, as for instance box **54**, from the outside surface of same, by appropriately opening up the knock-out opening **56**, and then taking the connector **50**, centering its tabs **60** on the knock-out opening **56** with the cam surfaces **65** placed against the outer margin **57** of the knock-out opening **56** at the box outer surface, and then pressing the connector **50** inwardly of the box or to the right of Figure 13 to cam the tabs **60** toward each other sufficiently so that the box wall margin **57** defining the knock-out opening **56** slips snap fit fashion into the connector seat **76**, and specifically into the recesses **76** between the respective tab shoulders and body rim segments to seat the connector **50** in the box knock-out opening **56**. Body segments adjust radially of axis **91** as needed by the relative size of the knock-out opening **56** to which the connector **50** is applied.

[0088] The connector **50** being formed partly from resiliently flexible material, after the connector is snap fitted in place in the box, the jaws **62** return under their built in resilient bias to the substantially normal positioning indicated in Figures 7-12. As already indicated, in the cable

free positioning of the fingers **94**, **94'**, **94''**, and **94'''**, the jaw heads **68** are spaced from the plane of seat, whereby they are free to flex outwardly of axis **91** when cable **58** is to be applied to the connector, as described hereinafter.

[0089] The connector **50** in accordance with the invention is adapted to be applied to the box knock-out opening **56** without using any special tools, and normally finger pressing acting on the body, and specifically against its side, is adequate to effect mounting of the connector in the box. This may be facilitated when necessary by a light tapping action on the side of body member with a hammer where the sizing of the knock-out opening is somewhat smaller than will accommodate finger pressure application of the connector to the box knock-out opening **56**.

[0090] Assuming that the end of a length of non-metallic sheathed cable **58** of the oval transverse cross-sectional configuration indicated in Figure 14 is to be applied to the box **54** through the connector **50**, the installer grasps the cable **58** adjacent the cable end **59**, and presses the cable end **59** against the inside cam surfacing of jaws **62** to force them apart to receive and pass the cable end **59**.

[0091] In this connection, the jaws **62** are arranged to receive the cable end **59** in any random or selected position of orientation about the axis **91** for complete convenience in applying the cable **58** to the connector **50** for cable of oval transverse cross-sectional configuration. In effecting the positioning, the installer will have applied the cable end **59** to the connector **50** so oriented that the long dimension of the cable transverse cross-sectional configuration is aligned with one of the pairs of jaws **62**, and is roughly centered on the connector central axis **91**. The cable end **59** is then pressed against the inside cam surfacing of the jaws **62** to force them apart somewhat so that the narrow side edges of the cable **58** will be lodged in and be engaged by the

respective gripping edges of jaws 62 and the cable wide sides will be engaged by the jaw rim portions of jaws 62. By pressing the cable end 59 inwardly of the box 54, the jaws 62 are in effect cammed to the respective spread apart relation, which accommodates ready sliding movement of the cable 58 inwardly of the box 54 with respect to the connector 50. This also disposes the gripping edges of the jaws 62 in abutting relation with the narrow sides of the cable, and the gripping edges of the jaws 62 in abutting relation with the wide sides of the cable. The built in spring action of the connector fingers 94, 94', 94'', and 94''' effects a light pressing action of the jaw rim portions, and thus gripping edges, on the external surfacing of the cable sheathing, but without any penetration within the cable sheathing. Insertion of the cable end 59 within the box through the connector 50 also somewhat outwardly angles or tilts the jaw heads 68 so that their jaw end portions project somewhat to the right of Figure 15, on a somewhat expanded relation from the centered relation about axis 91 that is shown in Figure 7.

[0092] However, jaws 62 are arranged so the cable end 59 may be inserted through connector 50 in any other position of orientation, relative to jaws 62, about axis 91, with the objective that some combination of the rim portions, and their gripping edges, of jaws 62 will provide the resilient gripping and withdrawal movement preventing action referred to, without penetrating the cable sheathing.

[0093] In any event, as long as the cable 58 is pressed to the right of Figure 13, the cable will move smoothly into the box through the connector 50 due to the cam follower type sliding action that the jaw heads 68 have on the cable sheathing. When the insertion movement stops, the jaws 62 will remain somewhat spread apart from the positioning indicated in Figures 7-12, with the jaws 62, and specifically their rim portions, bearing with light pressure on the cable sheathing,

and lightly indenting into, but not penetrating the cable sheathing. The non-metallic nature of the jaw rim portions and the bluntness of their gripping edges avoids risk of actual severing of the sheathing surface.

[0094] Should tension develop on the cable **58** tending to move the cable to the left of Figure 15, the frictional engagement that the jaws **62** have with the cable sheathing tends to draw the jaws **62** together in a collet like manner to swing toward closed position against the external surfacing of the cable to the extent permitted by the jaw cross spacing. This effects a further indentation of the jaw rim portions of the respective jaws, and specifically, their gripping edges , into the cable sheathing to provide a firm movement restraining hold thereon.

[0095] Thus, when wire **58** is first pushed through passageway **101** in Figure 10, it expands passageway **101** and deflects its outer surface. An opposite reactive force is thus generated in skeleton **100** which transfers this insertion force to wall **52** thereby resulting in firmer engagement of connector **50** with wall **52**. Consequently, upon the insertion of wire **58**, a greater force upon tabs **60** and flange **90** against wall **58** occurs than normally exists when no wire **58** extends through passageway **101**.

[0096] It will thus be seen that with regard to the oval type cable diagrammatically illustrated in Figure 14, the jaws **62** accommodate ready sliding movement of the cable inwardly of the connector and into the box to the extent desired. Tendencies of cable movement in the opposite direction tend to swing the jaw heads **68** somewhat to the left of Figure 15, and thus toward each other due to the purchase the jaws have on the cable by reason of the indentations that the jaw rim portions make in the cable sheathing surfaces they engage in, that thereby lock the cable to the connector and thus to the box **54**.

[0097] The connector 50 is thus in the nature of a self acting collet device in which the cable end 59 being inserted into the box 54 spreads apart the fingers 94, 94', 94'', and 94''' for slidably accommodating the cable's insertion, and tendencies of the cable 58 to move outwardly of the box swing the fingers 94, 94', 94'', and 94''' sufficiently in the opposite direction to lock the cable 58 to the connector 50 without causing any cutting or severing type penetration of the cable sheathing.

[0098] The connector jaws 62 are arranged to also accept round cable, for instance, the cable 58 that is diagrammatically illustrated in Figure 14. Round cable 58 is applied to the box 54 through the connector 50 in a similar manner, with the cable 58 end being pressed against the connector jaw inside cam surfaces 65 to separate the connector jaws 62, somewhat as indicated in Figure 14 so that the cable 58 can be slid inwardly of the connector jaws 62 into the box 54. In this positioning of parts, the round cable 58 becomes centered between the rim portions of the jaws 62 substantially as indicated in Figure 15. Again, as the cable is moved inwardly of the box, the cable sheathing slides smoothly over the jaw gripping edges, which edges are lightly pressed against the cable sheathing by the built in bias of the jaws that is occasioned by their being spread apart to insert the cable end into the box 54 through the connector 50.

[0099] The connector jaws 62 act to hold the cable 58 against withdrawal in a similar action as described in connection with the cable 58, with the edges indenting into the cable sheathing without cutting or severing the sheathing surface. It will therefore be seen that the invention provides a connector for non-metallic sheathed cable that is of one piece construction and adapted for ready application to box outlet openings utilizing the snap fit connection that has been described and illustrated, and without requiring any special tools to apply the connector to

the box or cable to the connector. The connector 50 is free of clamps and other similar types of mechanical connecting devices, and no clamp acting on the cable end is required within the box in which the cable end extends.

[00100] The connector comprising the invention readily accepts both oval and round non-metallic sheathed cable with equal facility, and permits a ready sliding action on the cable end into the box. Movement tendencies of the cable in the opposite direction are immediately halted by the collet like closing action of the connector jaws on the cable.

[00101] While the connector is preferably made from elastomer and plastic or its equivalent, the connector may also be formed from any other suitable plastic or polymeric material that is dielectric or electrically non-conductive. Metallic and other materials that which, if formed to a sharp edge or point, will readily sever the cable sheathing, should be avoided to avoid the possibility of the connector jaw teeth severing the cable sheathing.

[00102] The foregoing description and the drawings are given merely to explain and illustrate the invention and the invention is not to be limited thereto, except insofar as the appended claims are so limited, since those skilled in the art who have the disclosure before them will be able to make modifications and variations therein without departing from the scope of the invention. Various changes to the foregoing described and shown structures would now be evident to those skilled in the art. Accordingly, the particularly disclosed scope of the invention is set forth in the following claims.

WHAT IS CLAIMED IS:

1. A cord connector assembly comprising:
 - a skeleton part characterized by a circumferential hoop with an end and another distal end, said skeleton part having an outer flange and at least a pair of inwardly jutting pronged cable supports adjacent said end, and at least a radially outwardly protruding tab on said another distal end; and
 - a pliable shell over-molded around at least a portion of said skeleton part, said pliable shell having a center portion shaped to allow passage of a cable wire and provide strain relief to the cable wire but prevent passage of contaminants, wherein said protruding tab is configured to be pressed through a wall opening, and said protruding tab and said outer flange are fashioned to jointly and directly impart more force on either sides of the wall than force imparted by said pliable shell.
2. The cord connector assembly according to claim 1, wherein said center portion is a thin elastomer membrane which serves to plug the wall opening until pierced a by the cable wire and the connector assembly itself remains contaminant-free.
3. The cord connector assembly according to claim 1, wherein said strain relief and sealing characteristics defined by passage prevention of contaminants automatically occur upon the cable wire insertion and do not require any secondary operation or installation step.

4. The cord connector assembly according to claim 1, wherein the cord connector assembly has a low profile that eliminates any interference with another part of an electrical outlet box.
5. The cord connector assembly according to claim 1, wherein said center portion is configured, so that said center portion can accommodate a variety of different cord gauges.
6. The cord connector assembly according to claim 1, wherein the assembly is sized slightly bigger than the wall opening into which the assembly will fit so as to allow engagement with a non-standard opening size.
7. The cord connector assembly according to claim 1, wherein said pair of inwardly jutting pronged cable supports are curved upwardly away from said flange to make it easier to push the cable wire through and provide a high cable retention force further preventing removal of the cable wire once inserted.
8. The cord connector assembly according to claim 1, wherein said pair of inwardly jutting pronged cable supports extend from a region of said hoop closest to said flange to provide a stronger cable wire support and result in a low profile for the cord connector assembly.
9. The cord connector assembly according to claim 1, wherein said pair of inwardly jutting pronged cable supports extend from a mid-region of said end to provide a stronger cable wire support and result in a low profile for the cord connector assembly.

10. The cord connector assembly according to claim 1, wherein said pair of inwardly jutting pronged cable supports extend substantially close to said center portion and substantially close to each other to allow insertion of a wide range of different wire shapes and different gauges.
11. The cord connector assembly according to claim 1, wherein said pair of inwardly jutting pronged cable supports includes a mid-region that is slightly reduced in thickness, so that said inwardly jutting pronged cable supports will flex at a mid-region and not at a base.
12. The cord connector assembly according to claim 1, wherein each of said pair of inwardly jutting pronged cable supports is perforated so that said pair of inwardly jutting pronged cable supports will flex at a mid-region and not at a base.
13. The cord connector assembly according to claim 1, wherein the cord connector assembly is pivoted against the inserted cable wire so that the assembly projects outward from the cable wire at a 45 or less degree angle rather than at its normal 90 degrees, causing said cable supports to be mis-aligned with each other and enable the connector assembly to be slid off the cable wire.
14. The cord connector assembly according to claim 1, wherein said cable supports are slightly bent toward an end so that an insertion of the cable wire is supported, but an expulsion of the cable wire is made difficult, without excessive force, said cable supports including a plurality of deflectable appendages which are deflected by the passage of the cable wire through said center position, said deflectable appendages further restricting the removal of the cable wire back through said center position.

15. The cord connector assembly according to claim 1, wherein said flange has a plurality of apertures to engage with said pliable shell.
16. The cord connector assembly according to claim 1, wherein the cord connector assembly is made to plug into the wall opening in the same direction as the insertion direction of the cable.
17. The cord connector assembly as set forth in claim 14, wherein said deflectable appendages comprise a plurality of inwardly directed fingers having distal ends that are deflected by the insertion of the cable wire through the connector.
18. The cord connector assembly as set forth in claim 14, wherein said deflectable appendages comprise at least one curved edge arranged around the boundary of a cable wire passageway, said curved edge and said appendages being deflected by the insertion of the cable wire through the connector assembly.
19. The cord connector assembly according to claim 14, further comprising:
at least one additional tab spaced away from said flange wherein said tabs are deflectable so as to be pushed through the wall opening and wherein said flange prevents the further movement of the connector assembly through the wall opening.
20. The cord connector assembly according to claim 19, wherein at least one of said tabs and said flange forms a part of said skeleton.

21. A cord connector comprising:

(a) a pliable shell having a wire passageway therethrough;

(b) a rigid skeleton adjoining said shell also having a wire passageway therethrough, said skeleton having a plurality of deflectable appendages which are deflected by the passage of a wire through said wire passageway, said deflectable appendages further restricting the removal of said wire back through said wire passageway; and

(c) whereby said pliable shell seals around said wire in said wire passageway and said skeleton provides strain relief to said wire in said wire passageway.

22. The cord connector as set forth in claim 21, further comprising:

at least one tab spaced from a flange, wherein said tab is deflectable so as to be pushed through an opening and wherein said flange prevents the further movement of the connector through the opening.

23. The cord connector as set forth in claim 22, wherein at least one said tab or said flange form a part of said skeleton.

24. The cord connector as set forth in claim 21, wherein said deflectable appendages comprise at least one curved edge arranged around the boundary of said wire passageway, said curved edge and said appendages being deflected by the insertion of a wire through the connector.

25. The cord connector according to claim 21, wherein said shell includes a center portion formed of a thin elastomer membrane which serves to plug an opening until pierced by a cable wire and the cord connector itself remains contaminants-free.
26. The cord connector according to claim 21, wherein said strain relief and sealing characteristics defined by passage prevention of contaminants automatically occur upon the wire insertion and do not require any secondary operation or installation step.
27. The cord connector according to claim 21, wherein the cord connector has a low profile that eliminates any chance of interference with other parts in an electrical outlet box.
28. The cord connector according to claim 25, wherein said center portion is configured so that said center portion can accommodate a variety of different cord gauges.
29. The cord connector according to claim 21, wherein the cord connector is sized slightly bigger than an opening into which the cord connector will fit so as to allow engagement with a non-standard opening size.
30. The cord connector according to claim 21, wherein a pair of inwardly jutting pronged cable supports are curved upwardly away from said flange to make it easier to push the cable through and provide a high cable retention force further preventing removal of the wire inserted.

31. The cord connector according to claim 21, wherein said deflectable appendages are part of at least a pair of inwardly jutting pronged cable supports which curve upwardly in a direction away from said flange to make it easier to push the wire through and provide a high cable retention force further preventing removal of the wire once inserted.
32. The cord connector according to claim 21, wherein said deflectable appendages are part of at least a pair of inwardly jutting pronged cable supports extending from a mid-region of an end, or from a perimeter region of said skeleton closest to a flange to provide a strong support and a low profile for the cord connector.
33. The cord connector according to claim 21, wherein said deflectable appendages are part of at least a pair of inwardly jutting pronged cable supports extending substantially close to a center portion of the connector and substantially close to each other to allow insertion of a wide range of different wire shapes and gauges.
34. The cord connector according to claim 21, wherein said deflectable appendages are part of at least a pair of inwardly jutting pronged cable supports with a mid-region that is slightly reduced in thickness, and a base, so that said support will flex at said mid-region and not at the base.
35. The cord connector according to claim 33, wherein each of said pair of inwardly jutting pronged cable supports is perforated so that said support will flex at a mid-region and not at a base.

36. The cord connector according to claim 21, wherein the cord connector is pivoted against the inserted wire so that the cord connector projects outward from the wire at a 45 degree or less angle rather than at the normal 90 degrees of the cord connector, causing said deflectable appendages to be mis-aligned with each other and enable the cord connector to be slid off the wire.

37. The cord connector according to claim 21, wherein said deflectable appendages are slightly bent toward an end so that an insertion of the wire is supported, but an expulsion of the wire is made difficult, without excessive force, said deflectable appendages being deflected by the passage of the wire through a center position of the connector, said deflectable appendages further restricting the removal of said wire back through said center position.

38. The cord connector according to claim 21, wherein a flange includes apertures to engage with said pliable shell.

39. The cord connector according to claim 21, wherein the cord connector is made to plug into an opening in the same direction as the insertion direction of the wire.

40. The cord connector as set forth in claim 21, wherein said deflectable appendages comprise a plurality of inwardly directed fingers having distal ends that are deflected by the insertion of the wire through the cord connector.

41. The cord connector as set forth in claim 21, wherein said deflectable appendages comprise at least one curved edge arranged around the boundary of said wire passageway, said curved edge and said appendages being deflected by the insertion of the wire through the cord connector.

42. A method of manipulating a connector for insertion into and removal out of a wall aperture for reuse of the connector, the method comprising:

provide a connector with a skeleton part characterized by a circumferential hoop with an end and another distal end, said skeleton part having an outer flange and at least a pair of inwardly jutting pronged cable supports adjacent said end, and at least a radially outwardly protruding tab on said another distal end; and include a pliable shell over-molded around at least a portion of said rigid skeleton part, said pliable shell having a center portion shaped to allow passage of a cable wire and facilitate strain relief to the cable wire but prevent passage of contaminants, wherein said protruding tab is configured to be pressed through a wall opening and said protruding tab and said outer flange are fashioned to jointly and directly impart more force on either sides of the wall than force imparted by an extension of said pliable shell; and

skew /pivot said connector on the cable wire so that said connector projects outward from the cable wire at a 45 or less degree angle rather than at its normal 90 degrees; and

slide off said connector off the cable wire once said supports are mis-aligned with each other.

43. The cord connector as set forth in claim 22, wherein at least one said tab or said flange form a part of said pliable shell.

44. The cord connector as set forth in claim 21, wherein said deflectable appendages comprise a plurality of inwardly directed fingers, the fingers each having a distal end that is deflected by the insertion of the wire through the cord connector.

1/15

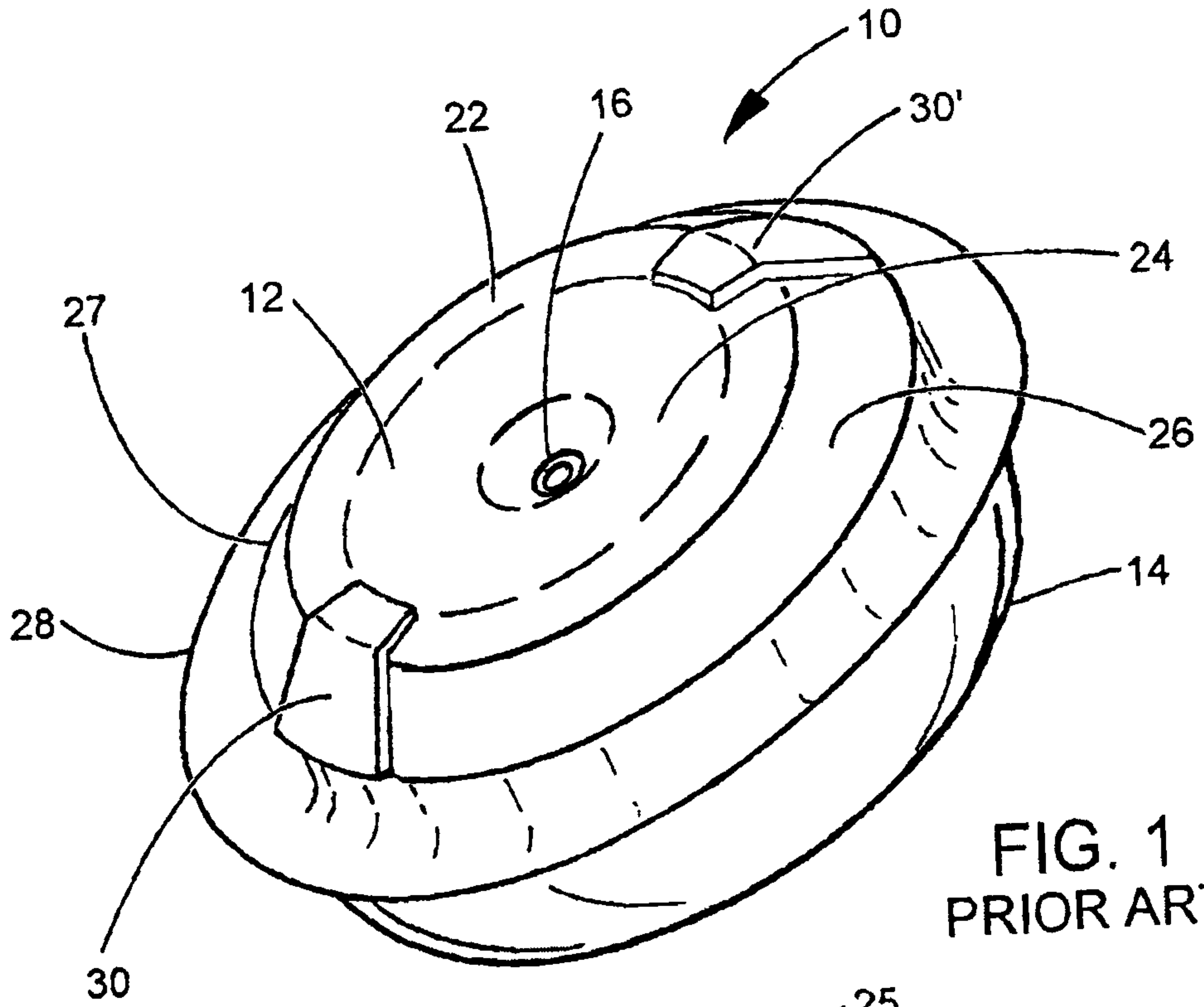

FIG. 1
PRIOR ART

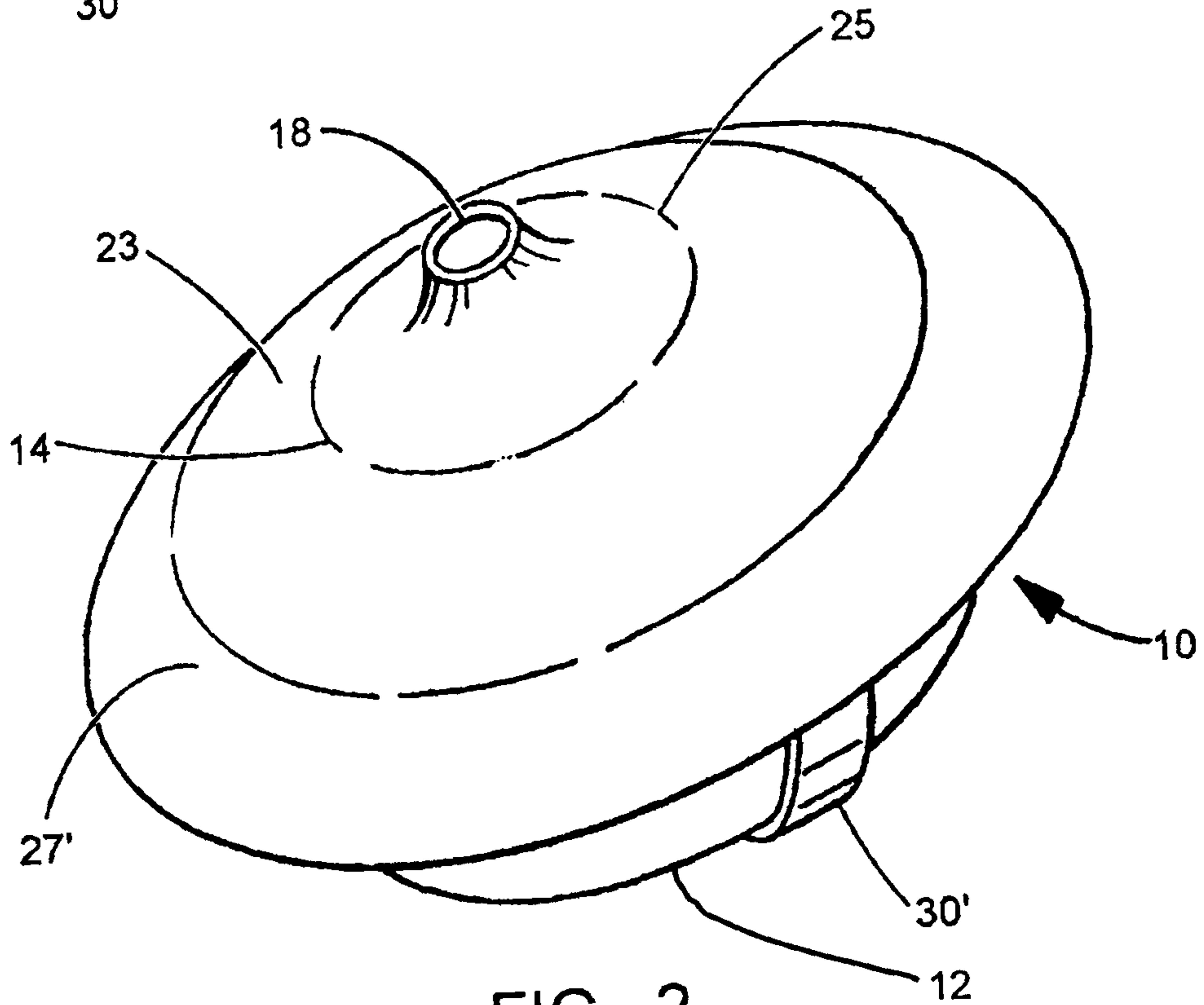

FIG. 2
PRIOR ART

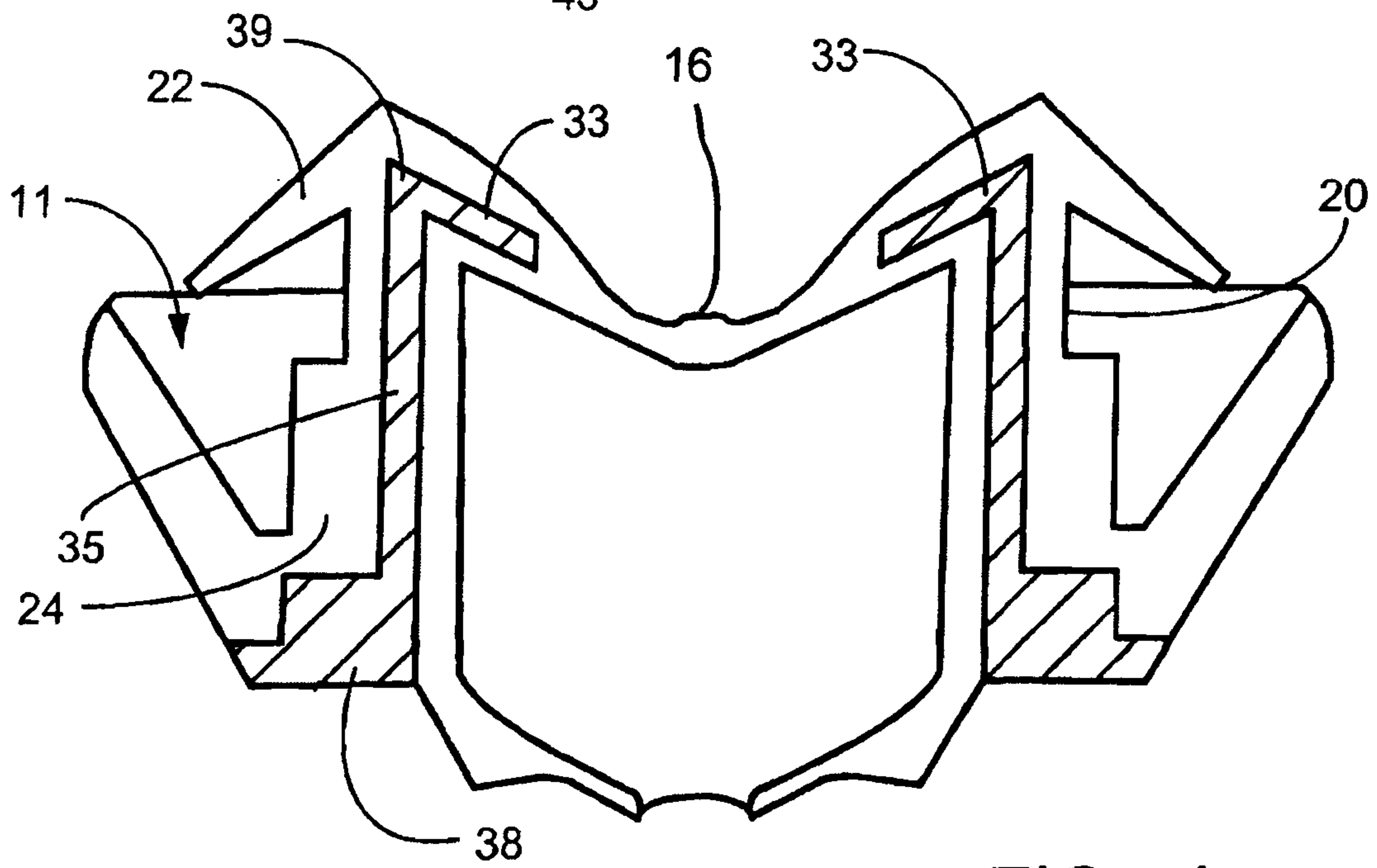
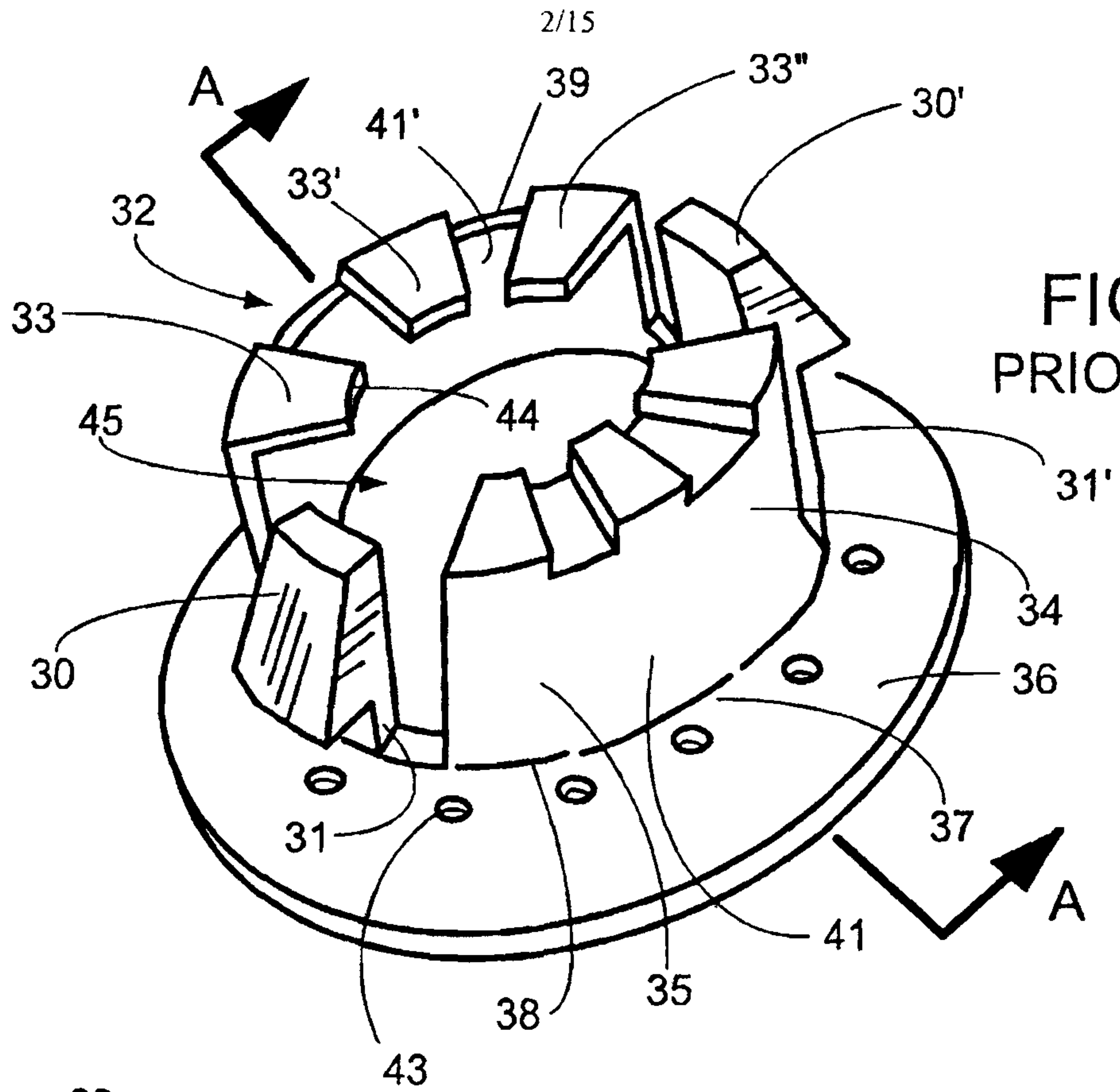

FIG. 4
PRIOR ART

3/15

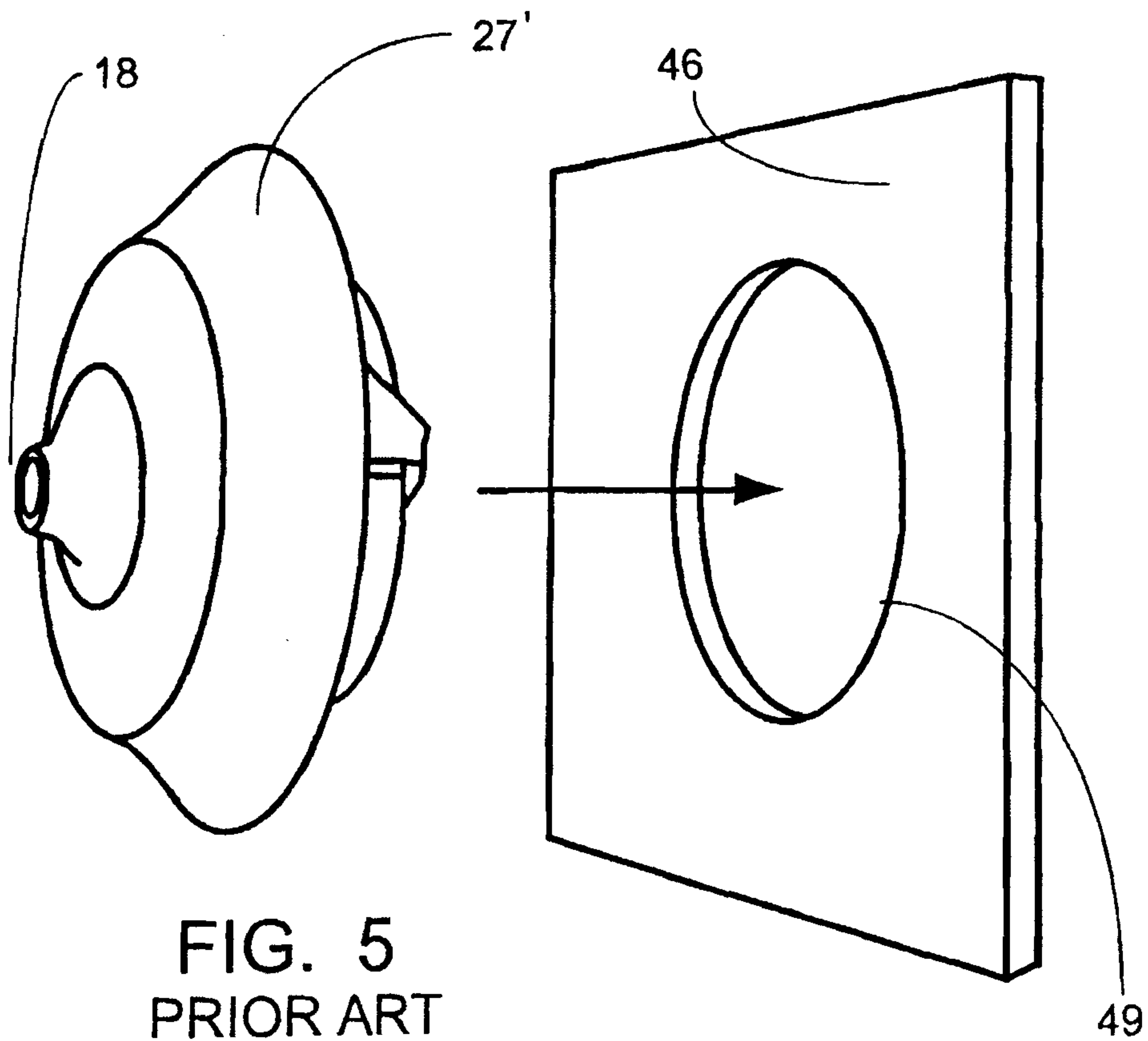

FIG. 5
PRIOR ART

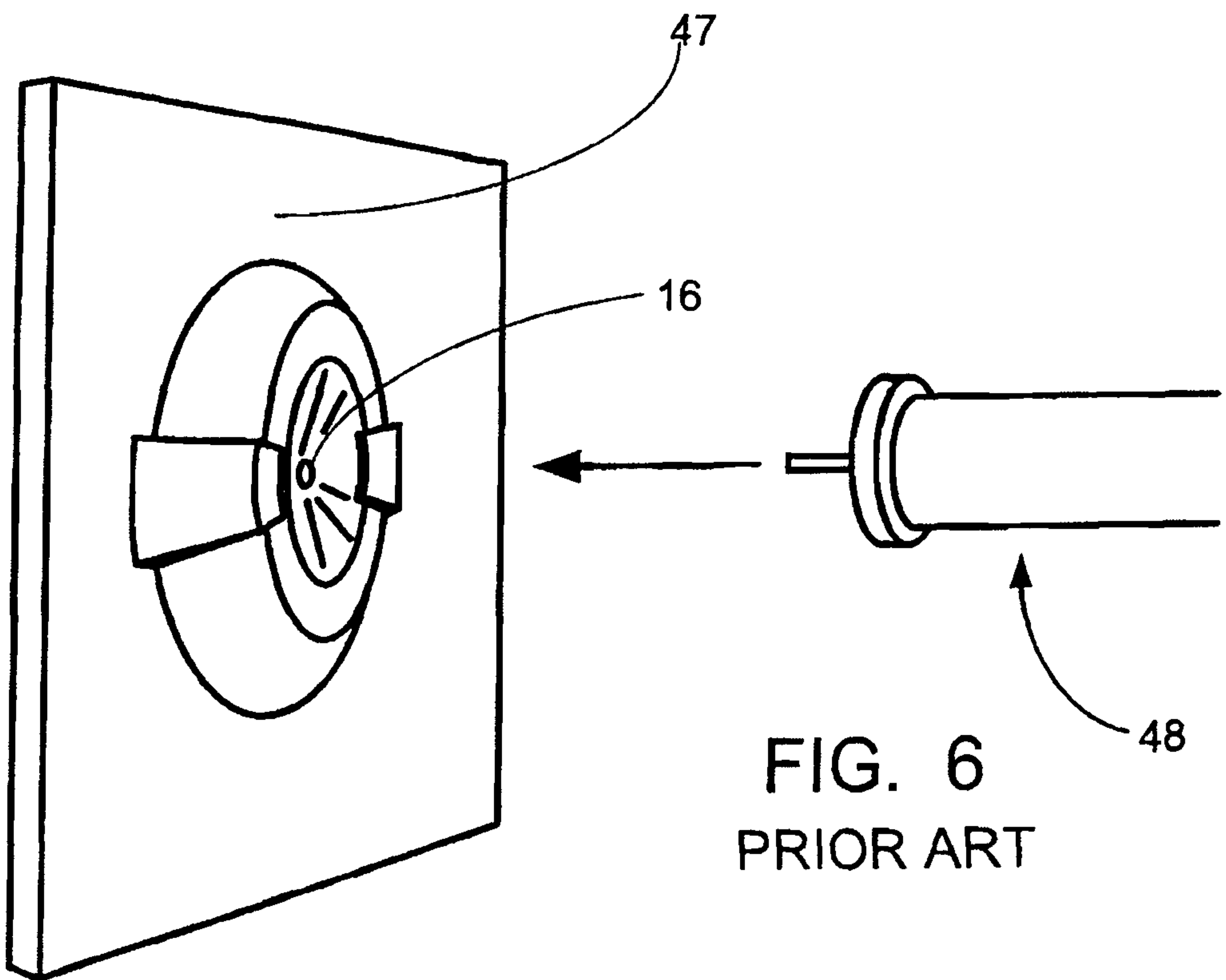

FIG. 6
PRIOR ART

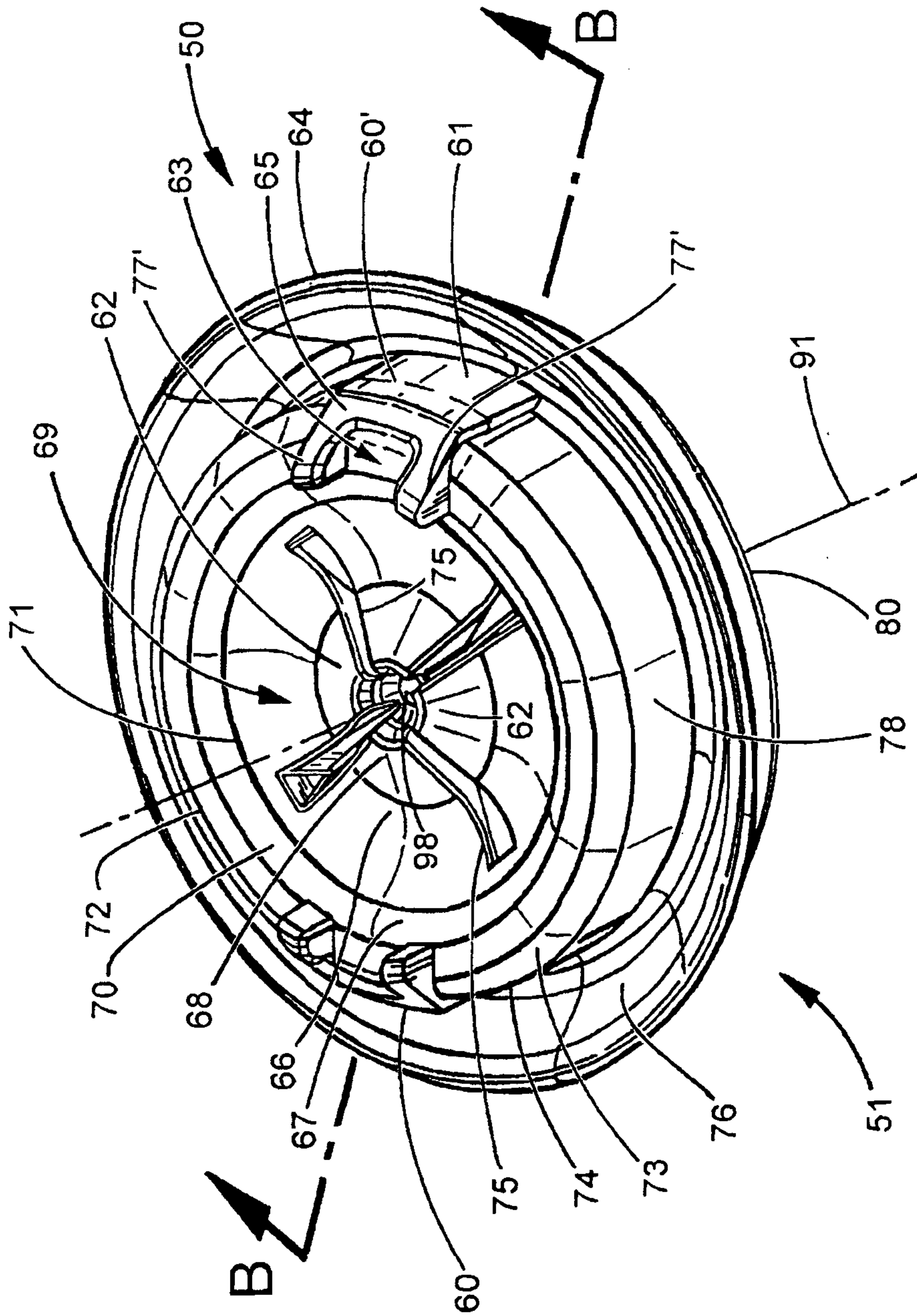

FIG. 7

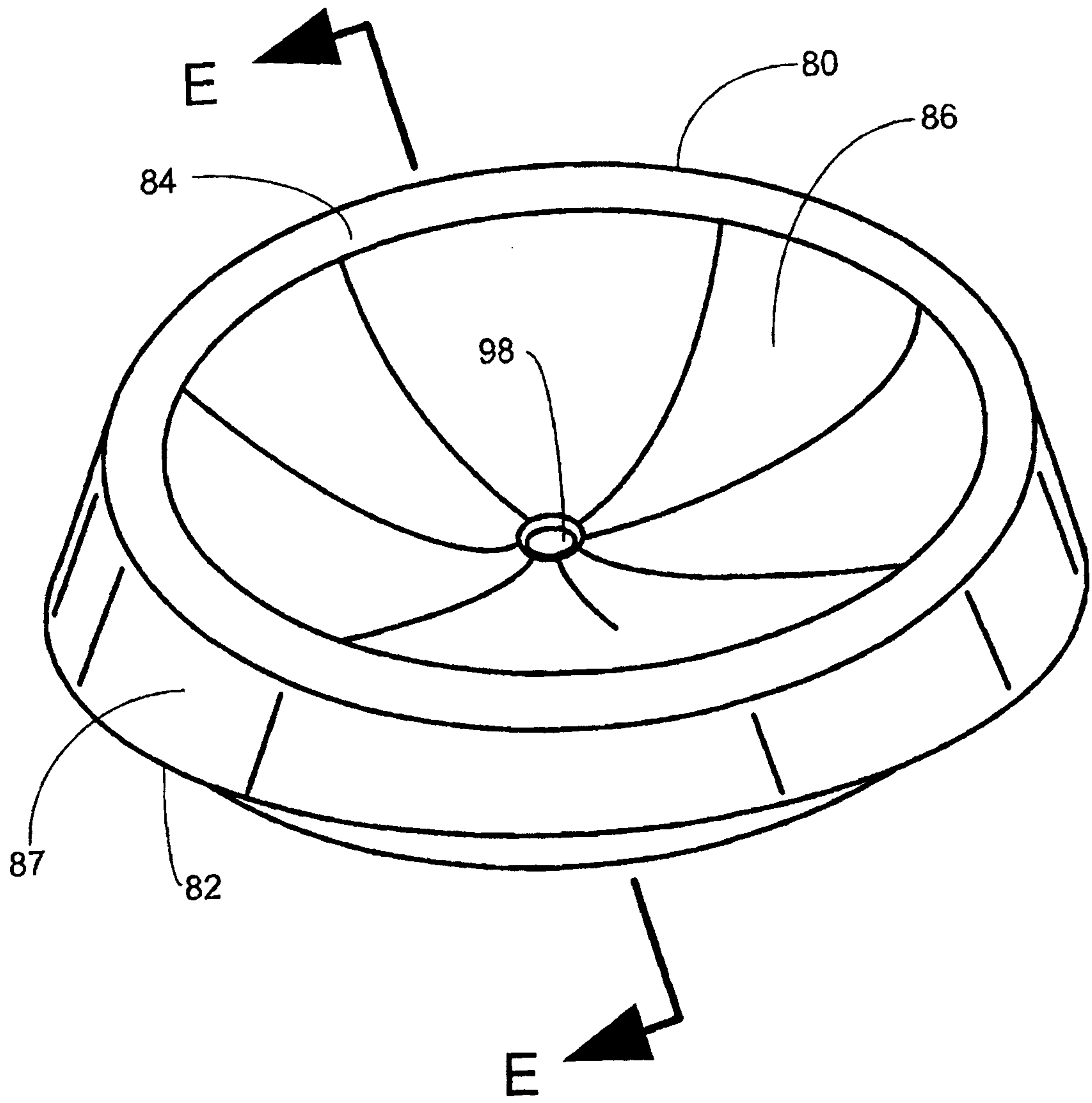

FIG. 8

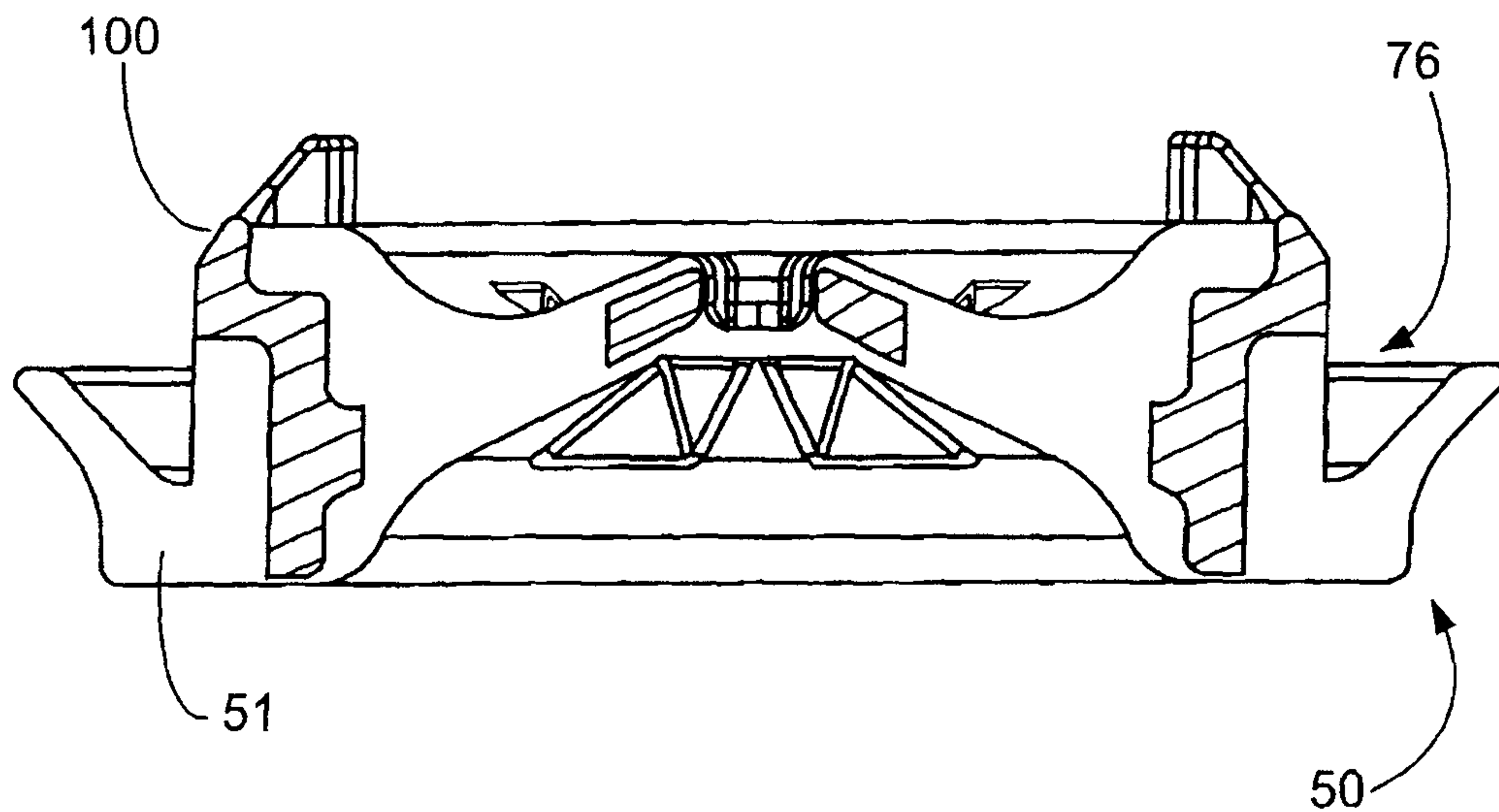

FIG. 8A

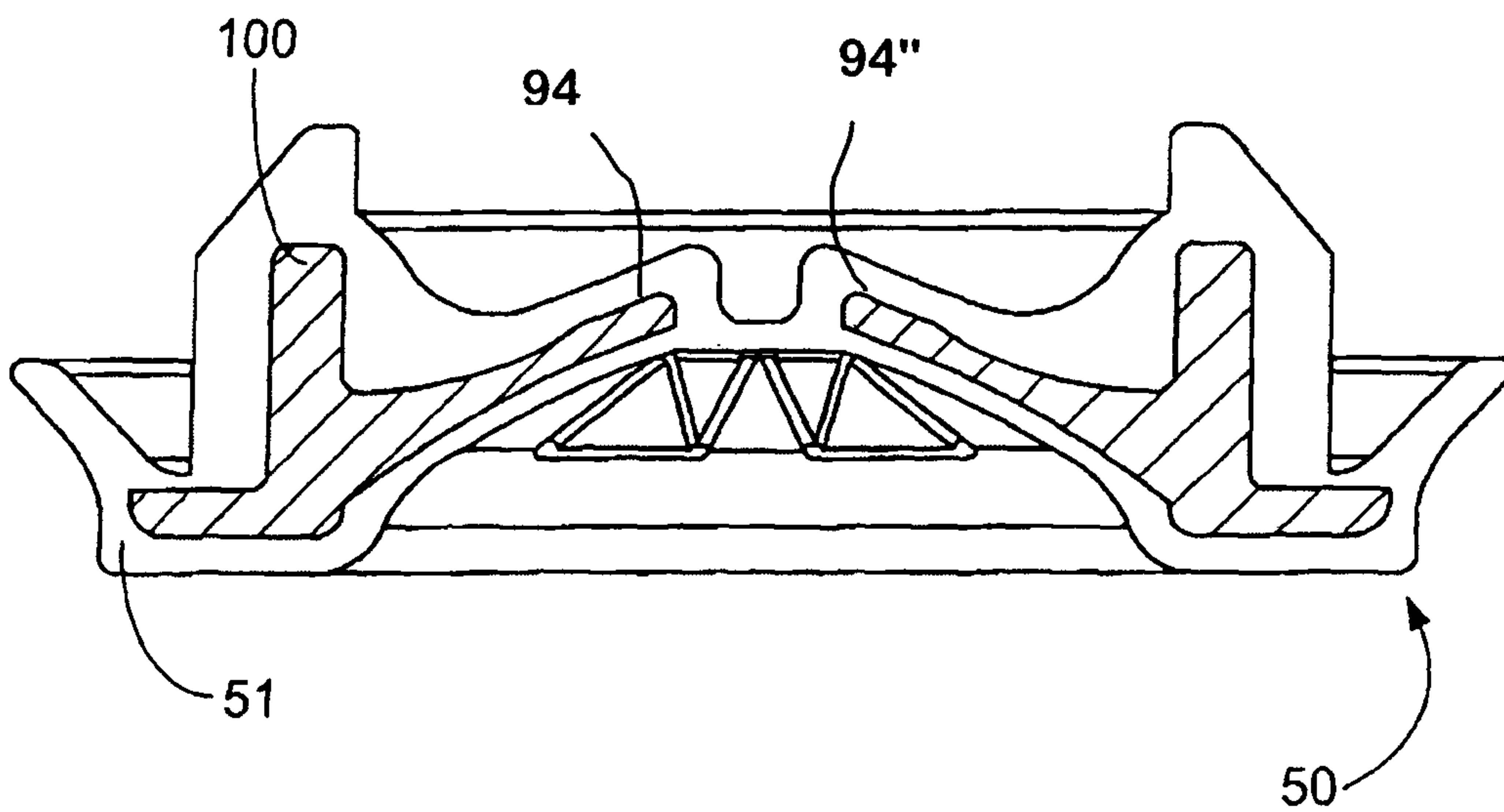
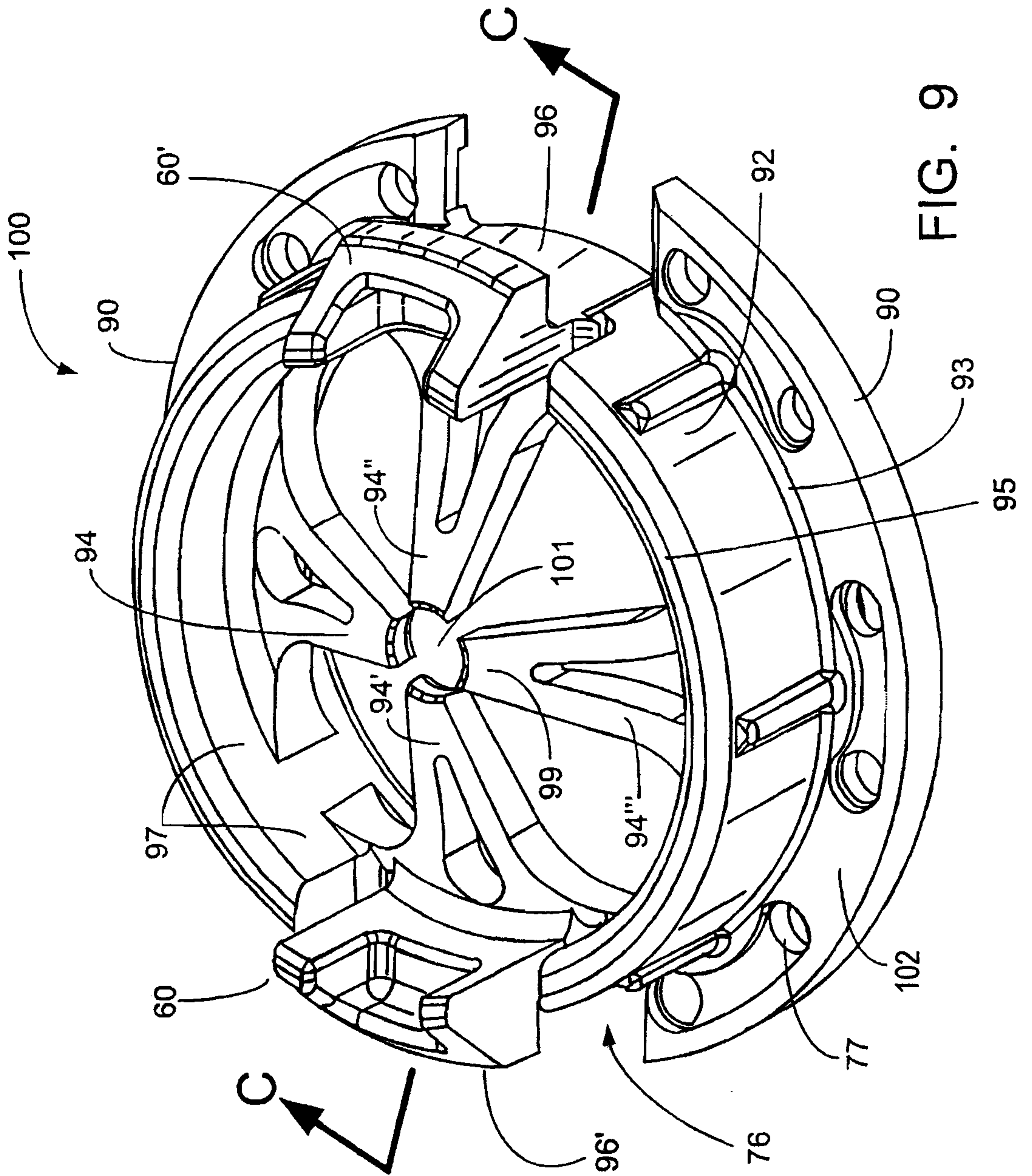

FIG. 8B



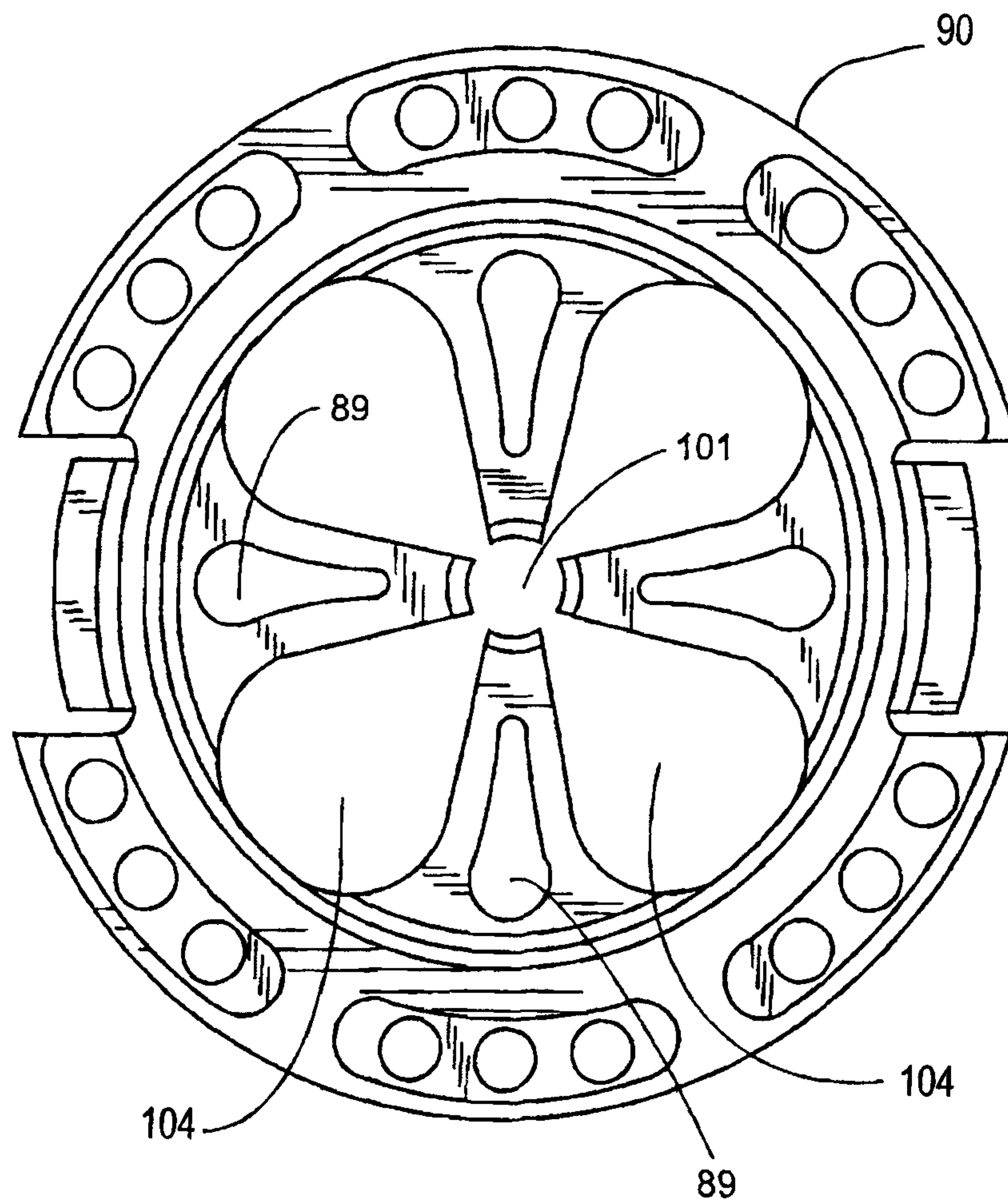

FIG. 10

9/15

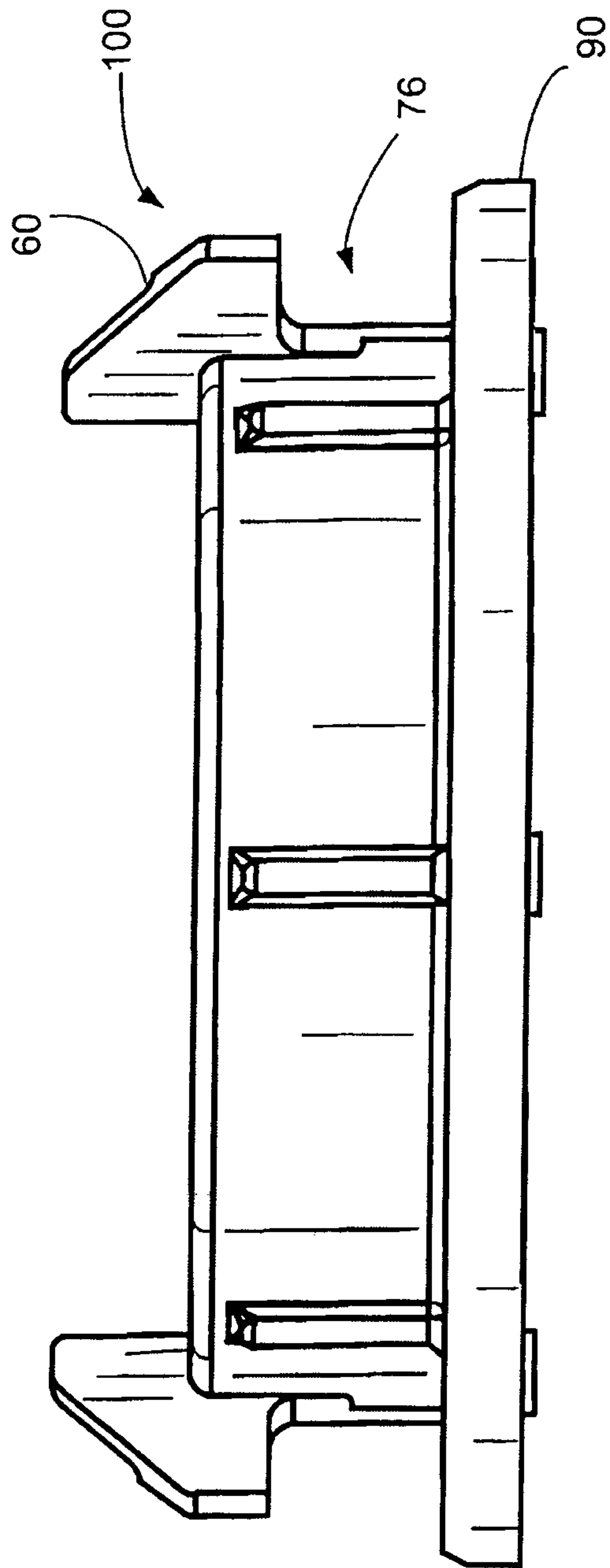

FIG. 11

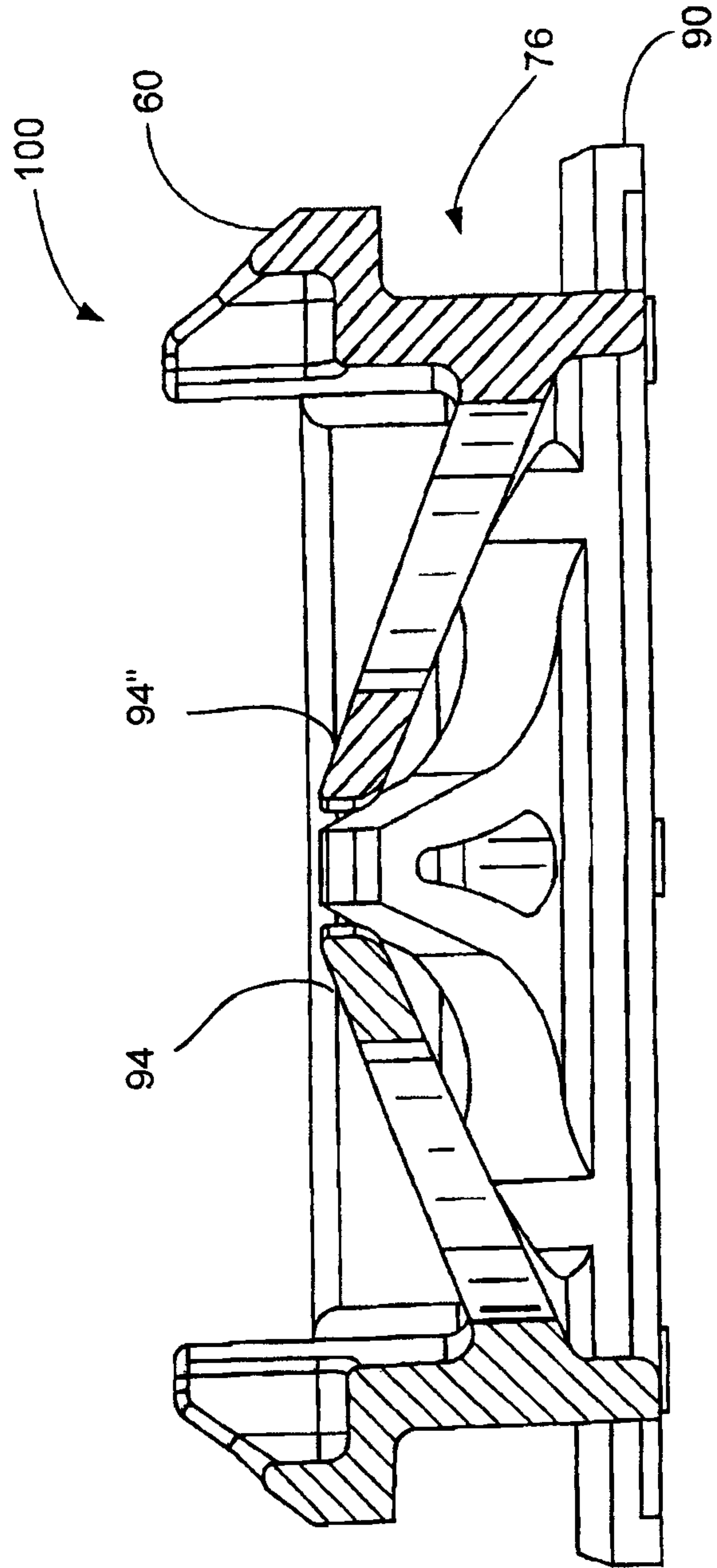
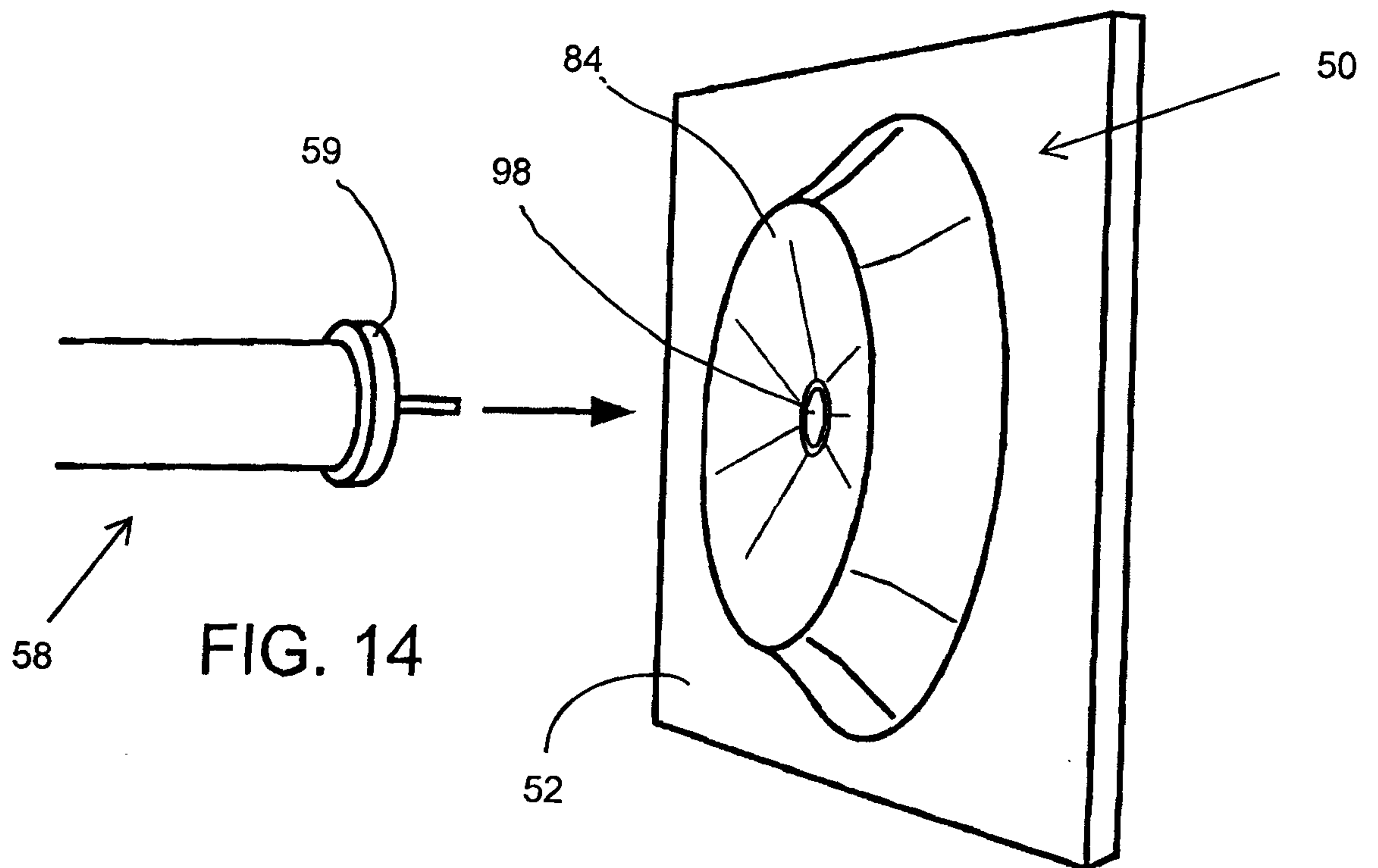
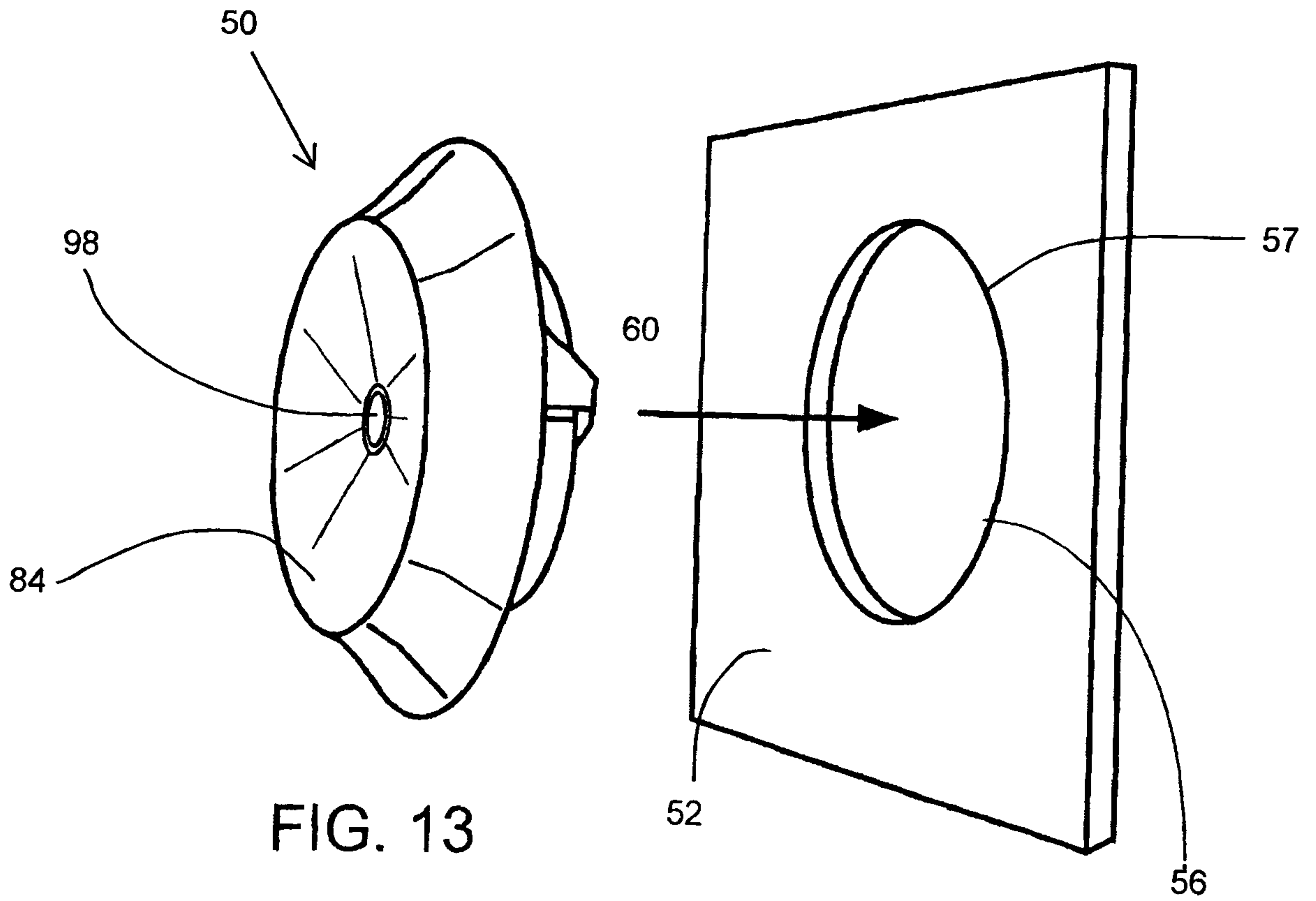

FIG. 12



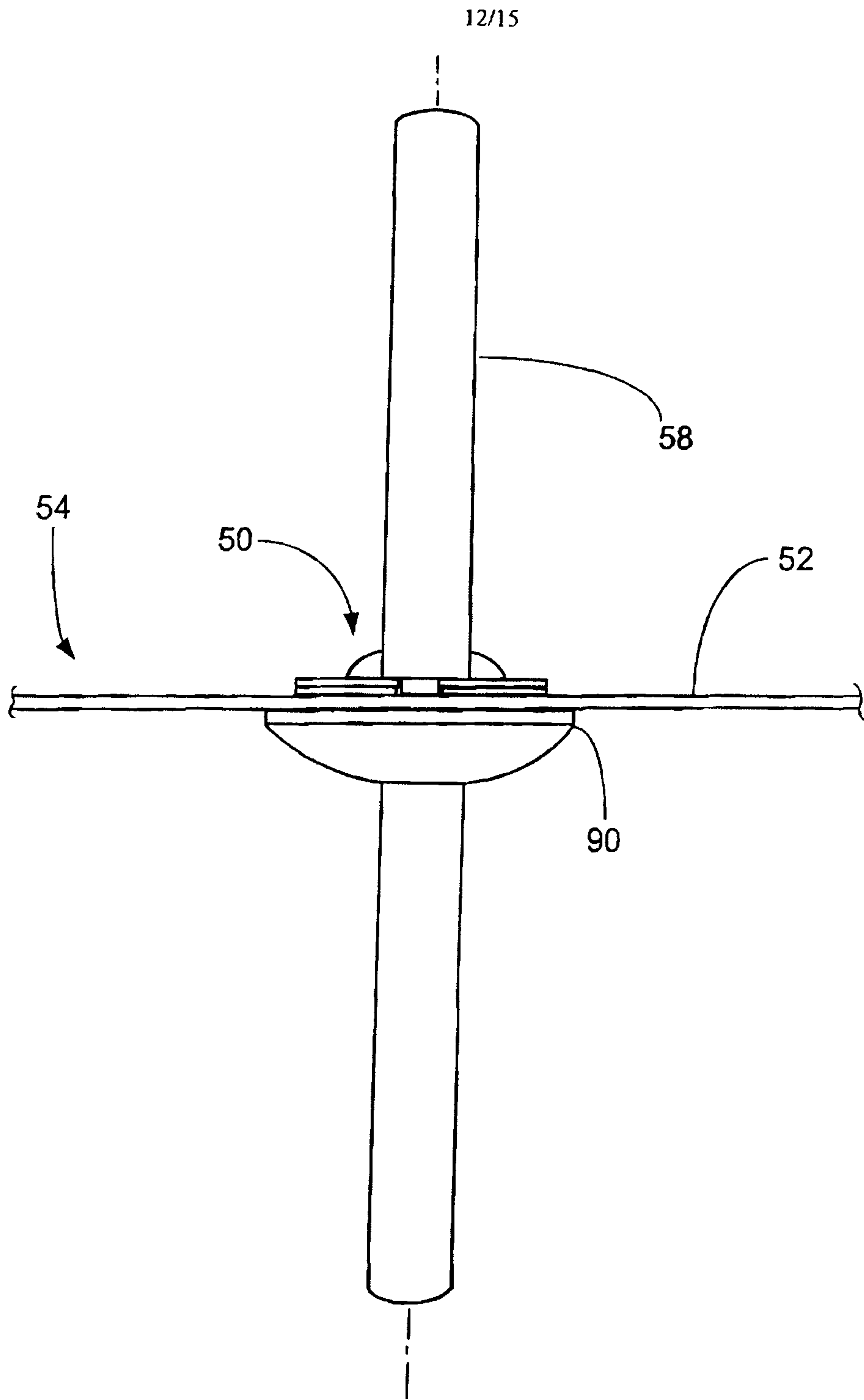

FIG. 15

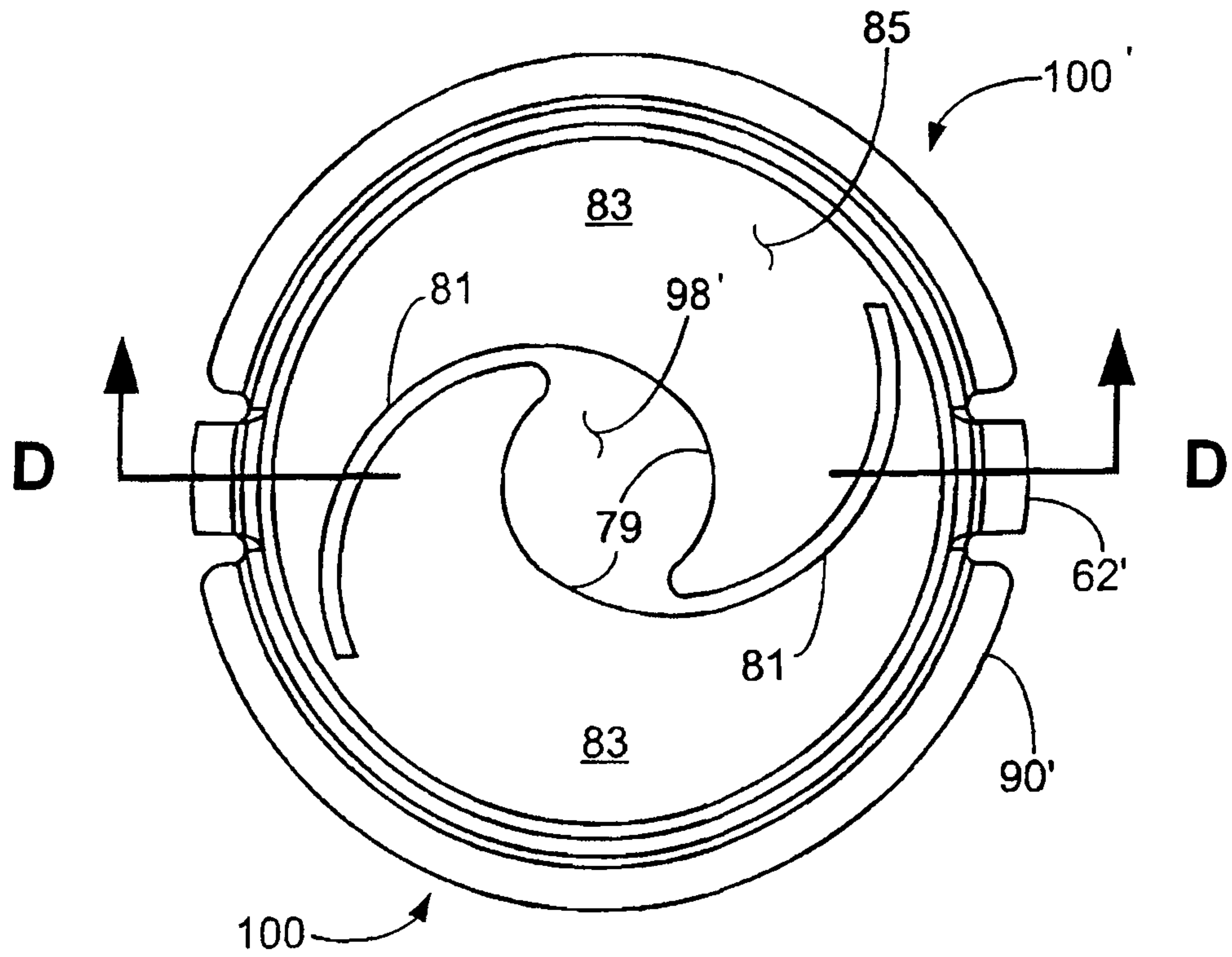

FIG. 16

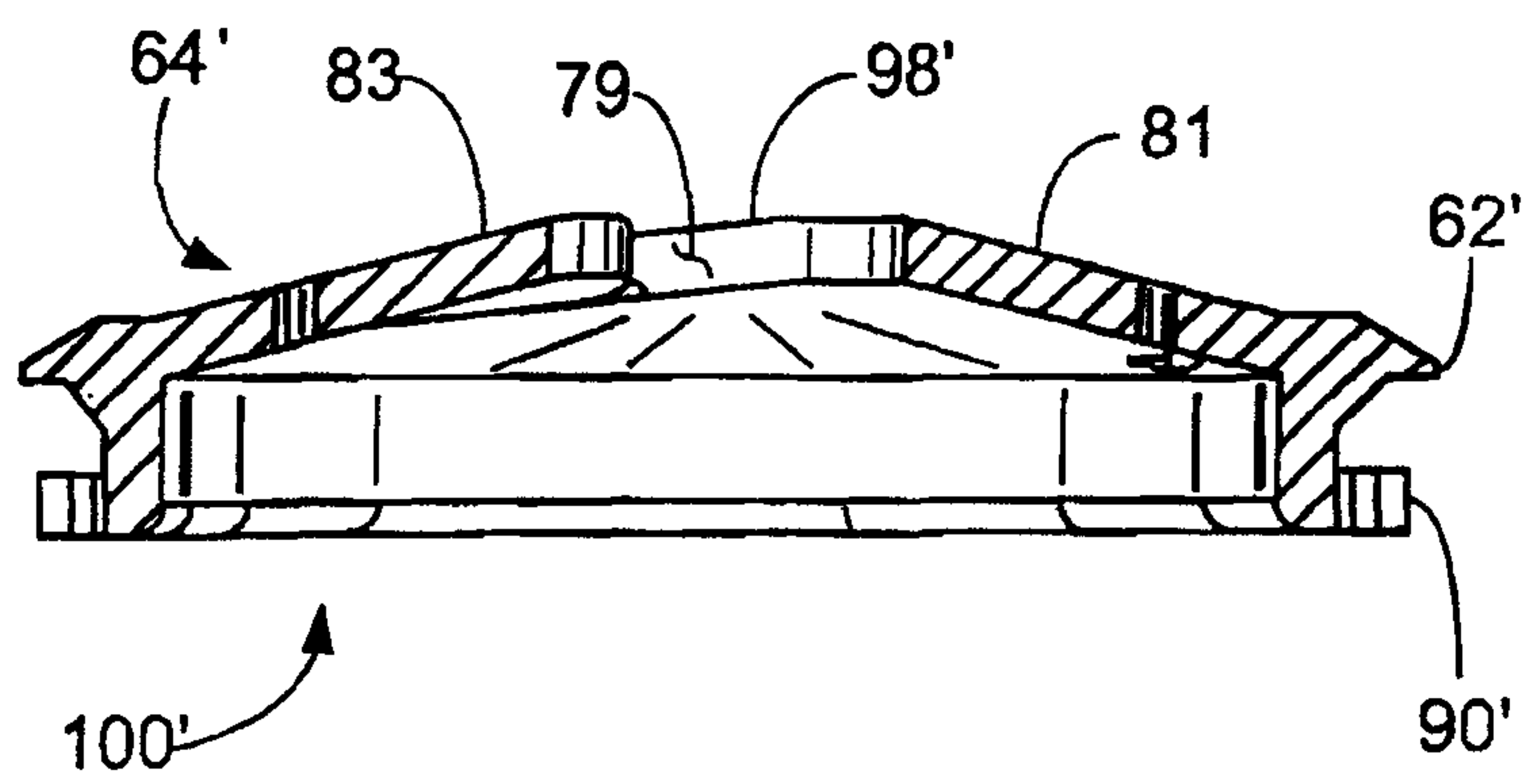

FIG. 17

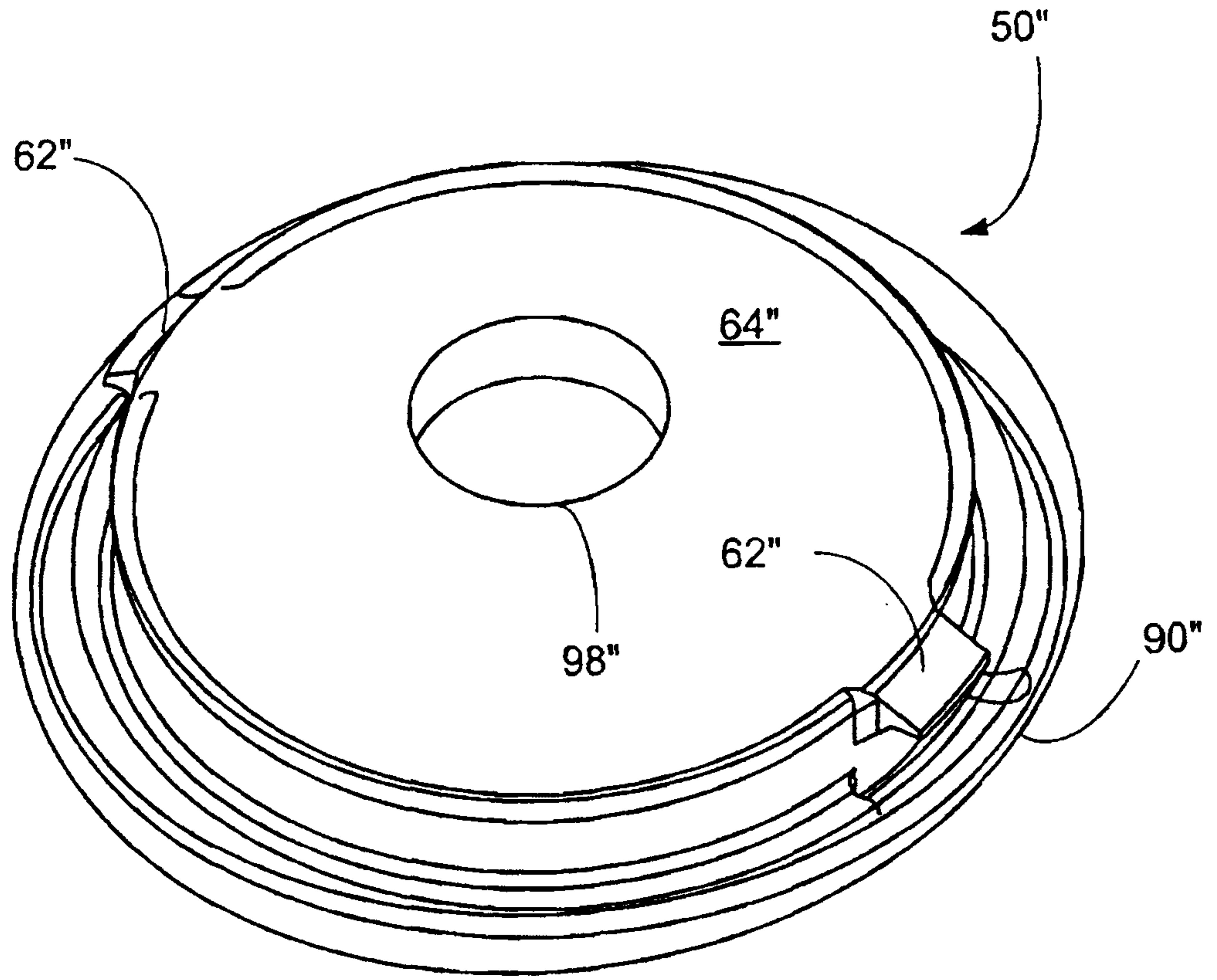

FIG. 18

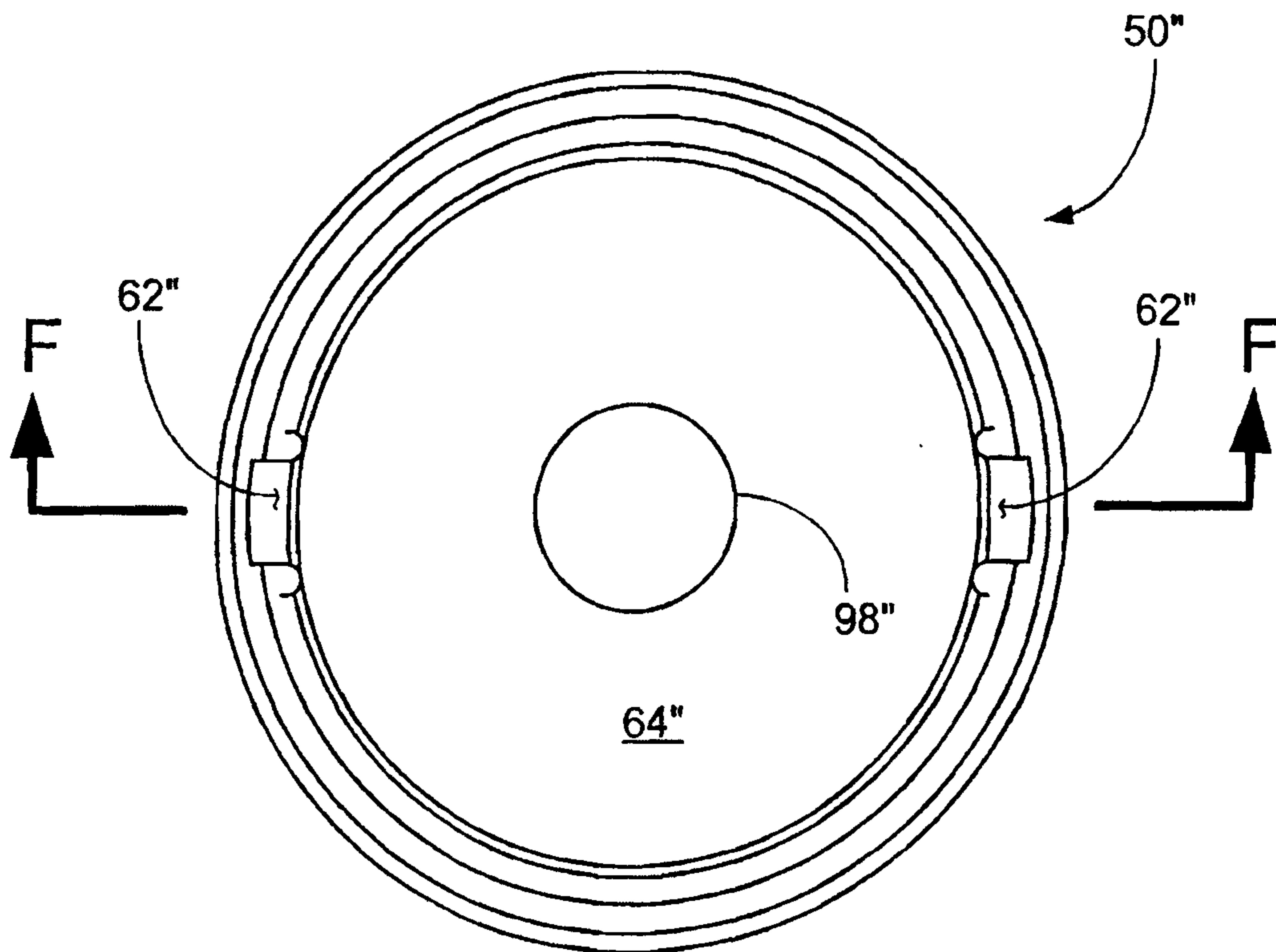

FIG. 19

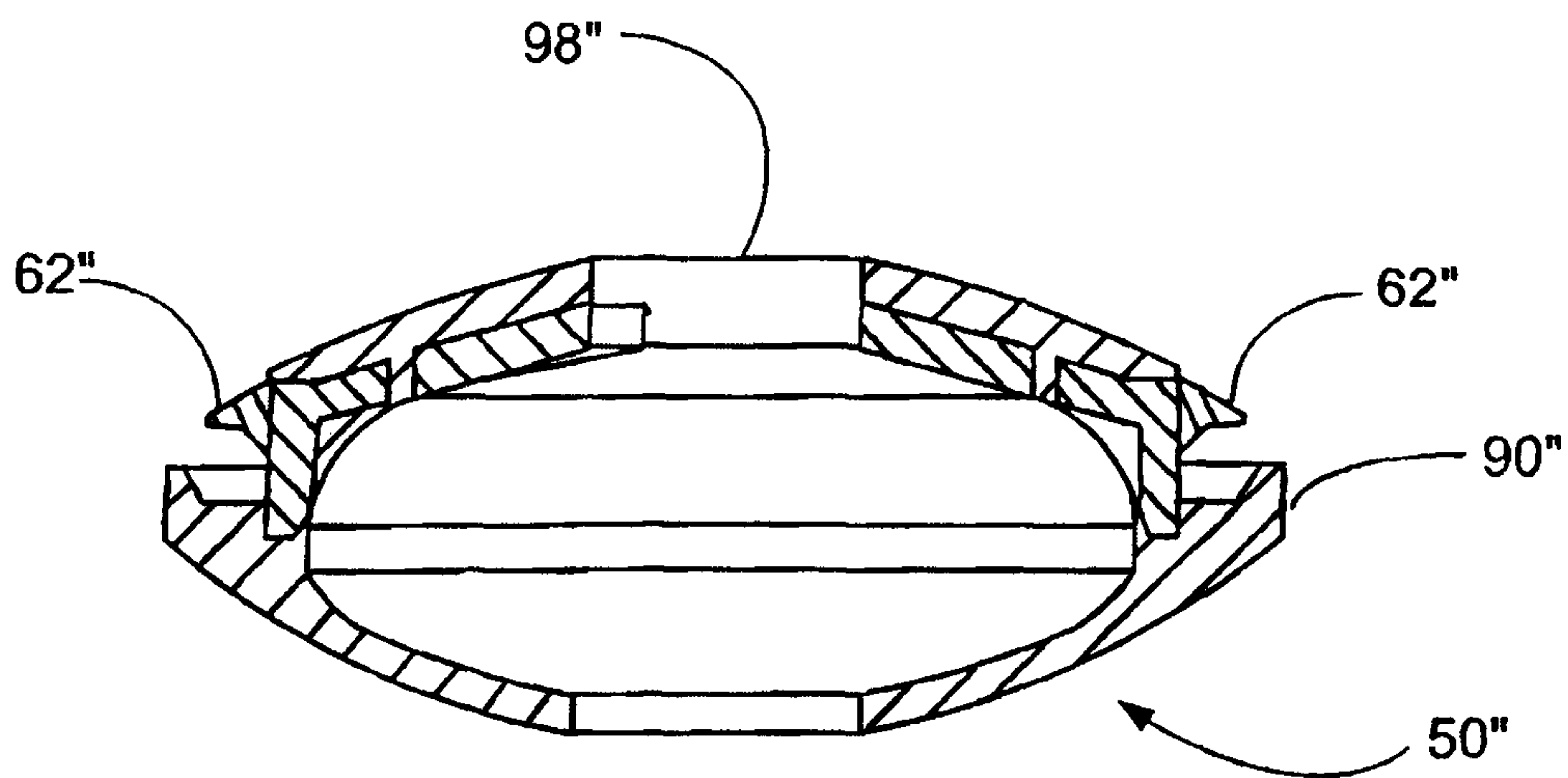

FIG. 20

