



- (51) International Patent Classification: *A61B 17/04* (2006.01)
- (21) International Application Number: PCT/US2012/021891
- (22) International Filing Date: 19 January 2012 (19.01.2012)
- (25) Filing Language: English
- (26) Publication Language: English
- (30) Priority Data: 13/011,858 21 January 2011 (21.01.2011) US
- (71) Applicant (for all designated States except US): **SYN-TORR, INC.** [US/US]; 1157 Harker Avenue, Palo Alto, CA 94301 (US).
- (72) Inventor; and
- (75) Inventor/Applicant (for US only): **MARTIN, Daniel** [US/US]; 1157 Harker Avenue, Palo Alto, CA 94301 (US).
- (74) Agent: **HOEKENDIJK, Jens, E.**; P.O. Box 4787, Burlingame, CA 94011-4787 (US).
- (81) Designated States (unless otherwise indicated, for every kind of national protection available): AE, AG, AL, AM, AO, AT, AU, AZ, BA, BB, BG, BH, BR, BW, BY, BZ, CA, CH, CL, CN, CO, CR, CU, CZ, DE, DK, DM, DO, DZ, EC, EE, EG, ES, FI, GB, GD, GE, GH, GM, GT, HN, HR, HU, ID, IL, IN, IS, JP, KE, KG, KM, KN, KP, KR,

[Continued on next page]

(54) Title: METHODS AND DEVICES FOR ANCHORING SUTURE IN BONE

(57) Abstract: An elongate rigid suture anchor is provided which is driven and impacted directly into bone. It has two ends, a distal end, which forms a hole in the bone, and a proximal end that penetrates the sidewall of the bone hole as the anchor is displaced proximally in the hole. A proximal force is applied to the suture anchor to displace the anchor proximally and cause tilting of the anchor. As the anchor is displaced proximally, the proximal end of the anchor enters obliquely into the sidewall of the hole.

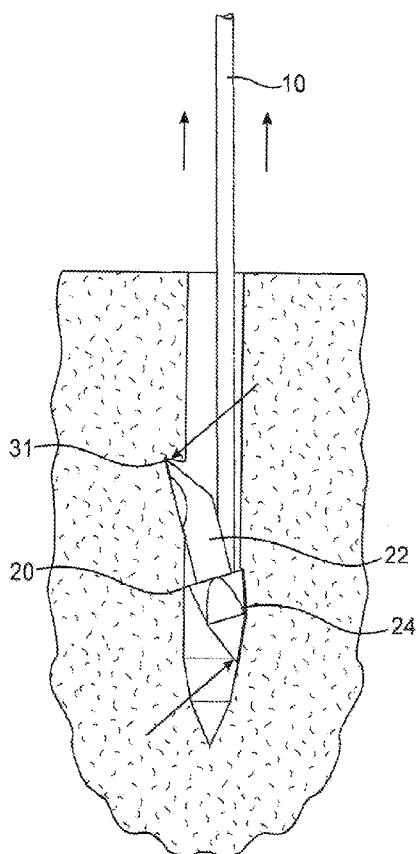

FIG. 10



WO 2012/100069 A1

KZ, LA, LC, LK, LR, LS, LT, LU, LY, MA, MD, ME, MG, MK, MN, MW, MX, MY, MZ, NA, NG, NI, NO, NZ, OM, PE, PG, PH, PL, PT, QA, RO, RS, RU, RW, SC, SD, SE, SG, SK, SL, SM, ST, SV, SY, TH, TJ, TM, TN, TR, TT, TZ, UA, UG, US, UZ, VC, VN, ZA, ZM, ZW.

DE, DK, EE, ES, FI, FR, GB, GR, HR, HU, IE, IS, IT, LT, LU, LV, MC, MK, MT, NL, NO, PL, PT, RO, RS, SE, SI, SK, SM, TR), OAPI (BF, BJ, CF, CG, CI, CM, GA, GN, GQ, GW, ML, MR, NE, SN, TD, TG).

**Published:**

**(84) Designated States** (unless otherwise indicated, for every kind of regional protection available): ARIPO (BW, GH, GM, KE, LR, LS, MW, MZ, NA, RW, SD, SL, SZ, TZ, UG, ZM, ZW), Eurasian (AM, AZ, BY, KG, KZ, MD, RU, TJ, TM), European (AL, AT, BE, BG, CH, CY, CZ,

- with international search report (Art. 21(3))
- before the expiration of the time limit for amending the claims and to be republished in the event of receipt of amendments (Rule 48.2(h))

# **METHODS AND DEVICES FOR ANCHORING SUTURE IN BONE**

## **BACKGROUND**

Suture anchors are used to anchor suture in various medical procedures such as glenoid labrum and rotator cuff surgery. The suture anchor is anchored into bone and one or more sutures are coupled to the suture anchor to hold the sutures in their intended position.

The present invention is directed to new methods and devices for anchoring sutures in bone.

## **SUMMARY**

In one aspect of the present invention, a suture anchor is provided which has a sharp distal end that forms the tip of the suture anchor assembly. The sharp distal end of the suture anchor is driven into bone directly to form a hole in the bone. As such, the suture anchor itself may act like a bone punch or a bone drill, which obviates the need for a separate device in a number of aspects of the present invention. The suture anchor is mounted to an introducer and is released once the suture anchor has been driven to the desired depth. The introducer is then withdrawn leaving the anchor impacted in the depth of the hole as further described below. Traction is then applied to the suture causing the anchor to move proximal in the hole and tilt. The tilting causes both the proximal and distal ends to engage the sidewall of the hole on opposing sides of the hole. Sidewall engagement holds the anchor in the hole. The pull-out resistance of the anchor in the hole is provided primarily by penetration of the proximal end into the sidewall in one aspect of the invention. Since the proximal end acts like a "spike" in the bone, the anchor may not have to be "tilted" as much as prior art anchors, which typically tilt 90 degrees, and may tilt less than 45 degrees.

In another aspect of the invention, the proximal end of the suture anchor penetrates the sidewall of the hole further than the distal end penetrates the sidewall. Many conventional suture anchors attempt to anchor tilting-type anchors with both ends penetrating the sidewall of the hole about the same amount. The proximal end of the suture anchor may be

driven into the sidewall of the hole so that at least half of a length of the suture anchor is driven into the sidewall along a side of the suture anchor. Stated another way, the suture anchor is driven into the sidewall so that at least part of a midsection of the anchor penetrates the sidewall with the midsection being a transverse plane lying halfway between the proximal and distal ends. While the proximal end may be preferentially driven into the bone, the distal end may not penetrate bone as much as the proximal end. Stated still another way, the proximal end may penetrate the bone a transverse distance which is at least three times larger than a transverse distance that the distal portion penetrates bone. In still another aspect of the present invention, a distance (measured along the longitudinal axis of the anchor), which the proximal end is driven into bone is at least three times larger than a distance (also measured along the longitudinal axis of the anchor) that the distal end is driven into bone.

In still another aspect of the present invention, the suture anchor may be formed in relatively small sizes so that the maximum outer transverse dimension of the anchor no more than four times the nominal USP diameter of the suture coupled to the suture anchor. Stated another way, when a plurality of sutures are attached to the anchor, the sum cross-sectional area of the sutures is at least 20% of the hole cross-sectional area (or the maximum bone anchor cross-sectional area).

These and other aspects of the present invention will become apparent from the following description of the preferred embodiments, drawings and claims

The details of one or more embodiments of the invention are set forth in the accompanying drawings and the description below. Other features, objects, and advantages of the invention will be apparent from the description and drawings, and from the claims.

## **DESCRIPTION OF DRAWINGS**

Fig. 1 shows a suture anchor mounted to an introducer.

Fig. 2 shows a suture anchor mounted to another introducer.

Fig. 3 shows the suture anchor.

Fig. 4 shows another view of the suture anchor.

Fig. 5 is a cross-sectional view of the suture anchor.

Fig. 6 is a cross-sectional view of another suture anchor.

Fig. 7 shows the suture anchor driven into bone to form a hole.

Fig. 8 shows the introducer removed and the view rotated 45 degrees relative to Fig. 7.

Fig. 9 shows the suture anchor moved proximally within the hole until the proximal end contacts the sidewall of the hole.

Fig. 10 shows the suture anchor displaced proximally within the hole so that the proximal end penetrates the sidewall of the hole and begins tilting.

Fig. 11 shows the suture anchor tilted further.

### DETAILED DESCRIPTION

Referring to Figs. 1-5, a suture anchor 2 and a suture anchor delivery system 4 are shown. The suture anchor 2 is mounted to a distal end 6 of an introducer 8. One or more sutures 10 are coupled to the suture anchor 2 and extend through a lumen 12 in the introducer 8. A suture lock 14 is positioned at the proximal end of the introducer 8 to maintain tension on the suture 10. Suture tension may be used to hold the suture anchor 2 at the end of the introducer 8 as described in further detail below. The suture anchor 2 may be held at the distal end of the introducer 8 using another removable suture (not shown) or any other suitable releasable connection without departing from numerous aspects of the present invention. The introducer 8 of Fig. 1 has a lumen 9 (see Fig. 5), which receives the suture 10. Alternatively, another introducer 8A is shown in Fig. 2 which has a slot 11 on an exterior surface in which the suture 10 resides. The particular introducer 8, 8A is selected depending upon the particular suturing procedure which will be undertaken by the user. Use of the introducer 8 is essentially the same as use of the introducer 8A and discussion of one is equally applicable to use of the other.

The suture anchor 2 has a tip 16 at a distal end 5 so that the suture anchor 2 may be directly driven into bone. The tip 16 has four beveled sides 18 that converge to form the tip 16. A shoulder 20 contacts the distal end 6 of the introducer 8. The shoulder 20 is generally

annular shaped and may have a slightly enlarged portion 22 along one side. The shoulder 20 separates the suture anchor 2 into a proximal portion 22 and a distal portion 24. The distal portion 24 gradually increases in cross-sectional area toward the shoulder 20. The suture anchor 2 may be formed from one piece of material so that the entire anchor is integrally formed or at least the portions which engage bone such as the proximal and distal ends. The suture anchor 2 may include other parts, including movable or deformable parts, without departing from this and other aspects of the invention so long as those parts are not associated with bone engagement in this aspect of the invention. For example, these parts may be associated with suture locking or release of the anchor from the introducer 8 rather than engaging bone. The suture anchor 2 may be made of any suitable material such as metal, ceramic or a high strength plastic. Of course, numerous aspects of the invention may be practiced with the suture anchor 2 being made of numerous parts which may or may not be movable or deformable and which may or may not engage bone.

The anchor 2 is driven directly into bone as will be described in further detail below. The anchor 2 itself forms the distal end of the device so that the anchor 2 forms the tip of a driver 23 which may act like a bone drill or serves as a bone punch. As such, the delivery system 4 is simplified since the anchor 2 itself forms the penetrating tip of the driver 23. Many other prior art anchors are delivered into a pre-drilled hole or are contained within the bone-hole forming instruments, rather than forming the tip of the driver 23 itself. The anchor 2 is driven directly into bone from the surface of the bone to the desired depth. The anchor 2 is then released by simply releasing the suture lock 14 and withdrawing the introducer 8 as described below. The distal portion 24 does not include a threaded exterior surface although various aspects of the present invention may be practiced with the distal portion 24 having a threaded exterior surface. Some conventional suture anchors are rotated into threaded engagement with the bone which may prevent the suture anchor from having the ability to be withdrawn within the hole in the manner that the suture anchor 2 can be withdrawn as explained herein.

The distal portion 24 of the anchor 2 is designed to become impacted at the bottom of the driven hole. To this end, the anchor 2 has an outer surface 26 that may form the largest transverse outer dimension of the anchor 2 and the introducer 8. The outer surface 26

may be sized larger than the introducer 8 to facilitate withdrawal of the introducer 8. When the anchor 2 is driven into bone, the outer surface 26 of the anchor 2 is impacted at the bottom of the hole so that the anchor 2 is frictionally engaged and held by the sides of the hole created by the anchor 2. The outer surface 26 is shown formed in four discrete parts but may, of course, be a single continuous surface or may be formed with more or fewer than four parts. The outer surface 26 may also be formed in any other manner such as two relatively small areas on opposite sides of the anchor so long as the opposing surfaces form the largest outer dimension of the anchor 2. The frictional engagement between the bottom of the hole and the outer surface 26 holds the anchor 2 so that the suture 10 must be pulled with a reasonable force to overcome this frictional engagement and catching of the edge of the shoulder 20 as described below in connection with use of the anchor 2. Prior art anchors which are advanced into a pre-drilled hole differ from this aspect of the present invention since such anchors sit loosely at the bottom of the hole rather than being impacted against the sides of the hole, and therefore require a special supplemental mechanism for deployment from the introducer tool or to initiate tilting of the anchor. As will be described above, the present invention may also be practiced without deformable or movable mechanisms or barbs that engage bone which many prior art anchors require.

The proximal portion of the suture anchor 2 extends proximally from the shoulder 20 and may include a keyed portion 28 having an exterior surface 30 that matches an interior surface of the introducer 8 so that torque may be transmitted from the introducer 8 to the suture anchor 2. The keyed portion may be a multi-faceted portion or may take any other suitable shape, such as oval as shown in Fig. 4, without departing from the scope of the invention. Of course, the keyed portion 28 may not be required if the anchor 2 is simply driven directly into the bone without rotation.

A proximal end 31 of the suture anchor 2 also has a sharp tip 32 to penetrate bone as described in greater detail below. One or more suture channels 34 may extend through the proximal portion and communicate with a recess 36 in the distal portion of the anchor 2. The suture channel 34 includes a slot 38 on one side, which permits the suture 10 to enter and leave the channel 34. Alternatively, the suture 10 when passing along the proximal portion may reside

partially or completely in a slot or groove in the most distal portion of the introducer, before proceeding proximally either into the lumen of the introducer or to a continuation of a slot on the side of the introducer without departing from the scope of the invention. A knot 35 may be formed in the suture 10, or other enlargement 11 on to the suture such as a metallic or polymer bead, clip, crimp, or other such attachment, to secure the suture 10 to the anchor 2. The knot 35 is positioned in the recess 36 with the ends of the suture 10 extending through the suture channel 34 and into the lumen 12 of the introducer 8. An opening 37 in the distal portion 24 is in communication with the recess 36 so that the suture 10 may be manipulated to secure the suture anchor 2 to the suture 10 or to secure and position the enlargement 11 onto the suture 10 and into the recess 36. The suture channel 34 may be positioned off-set relative to the center of gravity or geometric central axis CA (see Fig. 7) of the anchor 2 and the introducer 8 for the reasons described below in connection with use of the anchor 2. Alternatively, the recess 36 may be swaged, welded or glued to prevent removal of the suture 10 from the recess 36 with or without the knot 35. Referring to Fig. 6, another suture anchor 2A is shown wherein the same or similar reference numbers refer to the same or similar structure and all uses of the suture anchor 2 or suture anchor 2A are equally applicable to the other. The recess 36A may also include a curvilinear passage, which receives a sliding loop of the suture 10 with both ends passing through the suture channel 34 and proximally into control of the user. Alternatively, the anchor 2 may include a mechanism that permits unidirectional sliding of one or more sutures 10. Such a mechanism may include movable or deformable parts that engage the suture 10 but are not intended to engage bone.

Use of the suture anchor 2 is now described with reference to Figs. 7-11. The suture anchor 2 is driven directly into bone from the surface of the bone to form a hole in the bone. The introducer 8 may be rotated during driving of the suture anchor 2 to aid in advancing the anchor 2 into bone. The suture anchor 2 may also be driven into a pilot hole that is smaller or less deep than full insertion depth or width without departing from numerous aspects of the present invention. The pilot hole is sized smaller than the outer surface 26 of the anchor 2 so that the anchor 2 is still being driven into the bone to create the full transverse dimension of the hole H where it resides and so that the anchor 2 is impacted at the bottom of the hole. The hole in which the suture anchor 2 is positioned defines a longitudinal direction L and a transverse



direction T that will now be used to described aspects of the present invention. Once the suture anchor 2 has been driven to the desired depth, tension on the sutures is released by releasing the suture lock 14 (see Fig. 1). Releasing tension on the suture 10 releases the suture anchor 2 from the introducer 8. The suture anchor 2 may be coupled to the introducer 8 in any other fashion such as a second suture or a releasable connection such as a threaded connection between the suture anchor 2 and introducer 8. The introducer 8 may then be removed leaving the suture anchor 2 and the sutures 10 within the hole as shown in Fig. 8. The anchor 2 is held at the bottom of the hole by frictional engagement between the anchor 2 and the sidewall of the hole. No supplemental mechanism or component may be required to uncouple or expel the anchor from the end of the introducer although one may be provided without departing from numerous other aspects of the present invention. The anchor 2 also does not require a stiffened suture or stiff metallic cable to uncouple or expel the anchor from the introducer 8 although, again, one may be provided without departing from the invention. The anchor 2 sits within the hole without any engagement or contact of the proximal end 31 of the anchor 2 with the sidewall of the hole.

The suture or sutures 10 are then tensioned to produce a force on the suture anchor 2 that tends to move the anchor 2 proximally within the hole. When tension is initially applied to the suture 10, the anchor 2 resists movement due to the fact that the anchor 2 is impacted at the bottom of the hole. Upon application of sufficient tension on the suture 10, the frictional force holding the suture anchor 2 caused by impaction, and scraping of the corner of the shoulder 20, is overcome and the suture anchor 2 moves proximally within the hole. The initial proximal movement occurs with tilting until the proximal end of the suture anchor contacts the sidewall of the hole as shown in Fig. 9. Continued tension on the suture 10 causes the proximal end 31 (and the distal end to a lesser extent) to penetrate the sidewall of the hole. The anchor 2 advantageously may not require movable or deformable parts to engage the wall of the hole which makes for a simpler assembly than some prior art anchors which require deformable or actuated barbs or the like to engage the hole prior to or in association with proximal movement of the anchor 2. The anchor 2 also does not require an insertion shaft, which is pushed against the anchor to deform the anchor 2 or to move the proximal end 31 of the anchor 2 into engagement with the wall of the hole, or is elastically bent to bias a portion of the anchor against the sidewall, or holds a proximal corner of the anchor against the sidewall during

insertion. The anchor 2 also does not have and does not require an elastic connection or cable that will bias the anchor into a tilted position as soon as the anchor becomes separated from the introducer. The anchor 2 relies on the frictional engagement between the anchor 2 and the hole to initially resist the proximal force applied to the anchor by the suture 10. As mentioned above, the suture channel 34 (see Figs. 3-6) may be eccentrically positioned relative to the central axis CA (see Fig. 7) of the anchor 2 and the introducer 8 so that suture tension causes a moment to be applied to the suture anchor 2, which causes the anchor 2 to tilt within the hole, in association with proximal displacement, as shown in Fig. 9. Once the suture anchor 2 has tilted within the hole, the distal portion 24 may also penetrate the sidewall somewhat but much less than the proximal end. The distal portion 24 is relatively large compared to the proximal portion 22 so that the distal portion 24 does not easily penetrate bone when tension is applied to the sutures 10. The present invention has been described without use of a pusher to release the anchor or initiate tilting, however, numerous aspects of the present invention may be practiced with a pusher or insertion shaft without departing from the scope of the invention. A portion 35 of the shoulder 20 may penetrate the sidewall of the hole on the same side of the hole as the proximal end 31 of the anchor 2 and may serve as somewhat of a “stop” as the proximal end 31 is driven into the sidewall (see Fig. 11).

The proximal end 31 of the suture anchor 2 is driven into the bone like a “spike” which differs from many conventional anchors, which attempt to anchor both ends into bone somewhat equally rather than primarily the proximal end. The proximal end may tilt at an angle of less than  $45^\circ$ , which also differs from many conventional anchors that generally are tilted about 90 degrees. The proximal end 31 may be driven into the sidewall of the hole so that at least half of a length L (see Fig. 7) of the suture anchor 2 penetrates or intersects with the sidewall on at least one side of the suture anchor 2 as shown in Fig. 11. Stated another way, the suture anchor 2 is driven into the sidewall so that at least part of a midsection 33 penetrates or intersects the sidewall. The midsection 33 is a transverse cross section, which lies halfway between the proximal and distal ends. Stated still another way, the suture anchor 2 is driven into the sidewall a distance TD1 that is equal to at least half the length L of the suture anchor 2. While the proximal end 31 is preferentially driven into the bone, the distal portion 24 does not penetrate bone as much as the proximal portion 22 due to the larger cross-sectional size of the distal

portion, and the larger surface area that presents against the sidewall. As such, the proximal portion 22 may penetrate the bone with the transverse distance TD1 being at least three times larger than a transverse distance TD2 that the distal portion 24 penetrates bone. In still another aspect of the present invention, a distance 23 (measured along the longitudinal axis of the anchor 2) which the proximal end 31 is driven into bone is at least three times larger than a distance 25 (also measured along the longitudinal axis of the anchor 2) that the distal end is driven into bone. As mentioned below, the proximal and distal ends 22, 24 may in some circumstances, such as low bone density, penetrate the bone in a relatively equal manner without departing from other aspects of the present invention.

The suture anchor 2 displaces by design farther proximally in its hole, in the course of finding anchorage in bone, than do many other suture anchors. The proximal displacement is relative to the insertion hole transverse diameter. In other anchors that have their locking mechanisms biased against the sidewall with elastic or insertion-tools, or by notches in the sidewall, immediate engagement with the side-wall is made, preventing the anchor from displacing proximally in the hole. The suture anchor 2 may function somewhat differently in that the anchor may slide against the sidewall with the anchor 2 sliding at least one hole diameter and may even slide at least two hole diameters in some aspects of the invention. The suture anchor 2 may tilt at an angle of less than 45°, and may tilt as little as shown in Fig. 10 when in hard bone, although greater tilting may be accomplished without departing from the invention. With progressive sliding and penetration, the angle of penetration increases, as does the resistance to continued sliding and tilting.

The suture anchor 2 of the present invention may also be formed in relatively small sizes so that the outer surface 26, which represents the maximum outer transverse dimension of the anchor 2, is no more than 0.080 inch and may be, for example, about 0.062 inch. Stated another way, the suture anchor 2 may have a maximum outer transverse dimension (which is the outer surface in the preferred embodiment) that is no more than four times the nominal USP diameter of the suture 10. This small size is made possible because the design may be a single piece fabrication without moveable parts or elastic elements, and thus can be made in small sizes.

The suture anchor 2 has special characteristics that allow the use of relatively large sutures attached to the anchor 2. The design makes possible using attached sutures with nominal sum total cross sectional area of at least 20% of the anchor maximum cross sectional area when a plurality of sutures are coupled to the suture anchor. The anchor maximum cross sectional area is generally represented by a disc having a diameter equal to transverse dimension of the distal portion adjacent to the shoulder. As an example, an anchor of 0.063 inch transverse dimension can accommodate a double strand of USP No. 2 suture, USP No. 2 suture having a nominal diameter of .020 inch.

Having relatively large sutures attached to the anchor is beneficial to clinical application because a relatively small transverse dimension suture anchor may be affixed to a strong and thick suture. The small entry hole of the suture anchor inflicts less volume damage on the bone, and allows closer proximity of multiple anchors. The thicker suture is generally stronger and is less inclined to cut through the soft tissue structures being repaired.

Integration of multiple aspects of the invention makes the use of relatively large suture size and small suture anchor possible. The suture recess 36 is positioned in the distal portion, where there is sufficient space to accommodate the enlargement 11 on the suture. The suture channel 36 in the proximal portion allows passage of large sutures within the introducer adjacent to the proximal portion. A deployment tool is absent in the introducer lumen, making space for large sutures compared to some anchors, which require a deployment mechanism or tool. Absence of a deployment tool also allows for greater material cross section of the introducer, allowing the introducer to deliver the forces necessary for driving the anchor into bone without pre-drilling. The shape of the distal portion leads to impaction of the anchor at the conclusion of the driving step, allowing the introducer to be withdrawn away from the anchor without a supplemental deployment tool. In the slotted configuration of the introducer, the self-deploying nature of the anchor is again essential, because the slot precludes a lumen in the introducer for passage of a deployment tool. Relatively large suture size, especially in suture anchors that are self-driving, is a difference between some aspects of the present invention and many conventional anchors.

The differential sizes and shapes of the proximal and distal portions 22, 24 of the suture anchor 2 are also an aspect of the invention. The distal portion 24 penetrates the bone to form the hole in the bone while the proximal portion 22 penetrates the sidewall of the hole that is formed. The transverse dimension of the distal portion 24 forms a bone hole having the same transverse dimension as the distal portion so that the anchor 2 is impacted at the bottom of the hole. The introducer 8, on the other hand, may be slightly smaller than the hole. The impaction of the anchor 2 first functions to cause the anchor 2 to disengage out of the introducer 8 upon withdrawal of the introducer 8 without any accessory mechanism or deployment tool. The impaction secondly causes some resistance to a traction force subsequently applied to the suture, such that tension on the suture causes a tilting moment on the anchor 2 when the suture is tensioned. The large transverse dimension and associated surface area causes the distal portion 24 to slide against the sidewall, with minimal penetration of the sidewall, as the anchor 2 is displaced retrograde in the hole. The proximal portion 22 has the sharp tip 31, presenting minimal surface area to the sidewall as it contacts the sidewall, leading to penetration of the sidewall primarily by the proximal portion 22. The onset of penetration, or catching, of the sidewall by the proximal end 31 is one aspect of the invention, because this causes the traction force on the suture to deliver a force on the proximal end 31 directed into the sidewall. This force in turn causes further penetration and tilting of the anchor 2. The proximal portion 22 is of a smaller maximum transverse dimension than the distal portion, in order that there is space for the introducer that fits over the proximal portion, the introducer being not substantially larger in transverse dimension than the distal portion. The smaller transverse dimension of the proximal portion 22 also allows tilting of the anchor 2 so that the proximal end 31 may engage and penetrate into the sidewall of the hole as the anchor 2 slides retrograde. The shoulder may be designed to make possible numerous functions of the anchor 2. The shoulder may, of course, act as the contact surface for transferring forces from the introducer 8 to the anchor 2 during advancement of the anchor 2 in bone. The shoulder may also help initiate tilting by “catching” the sidewall of the hole during initial tensioning of the suture. Finally, the shoulder may also act as a stop as the proximal end is driven into bone as described above. The shoulder critically integrates with other design elements. The surface of the shoulder may be at an angle to the anchor-axis different than 90° without departing from the invention, though 90° is considered to be an optimal angle. The taper of the distal portion also allows tilting of the anchor sufficient for

the proximal tip to touch against the sidewall and begin entry into the sidewall of the hole. The smaller transverse dimension and small transverse tip cross section of the proximal portion 22 also allows penetration by the proximal portion 22 more easily than by the distal portion 24, causing a tendency to slide against the sidewall by the distal portion 24, and a tendency to penetrate the sidewall by the proximal portion 22.

The present invention has been described with reference to preferred embodiments, however, it is understood that numerous modifications could be made without departing from the scope of the invention. For example, in association with special bone morphology, both ends of the anchor may penetrate the bone equally or relatively equally without departing from aspects of the invention. The distal portion may be shaped in alternative ways to facilitate driving into bone, for example in a cone shape, or intersecting cone shapes, or with a shape having beveled sides numbering other than four, or having beveled sides each with a single slope, or as a foreshortened spade-point drill.

**WHAT IS CLAIMED IS:**

1. A suture anchor assembly, comprising:  
an introducer;  
a suture;  
a suture anchor coupled to the suture and to the introducer, the suture anchor having a distal portion and a proximal portion, the distal portion having a distal end shaped to penetrate bone, the proximal portion having a proximal end also configured to penetrate bone, the suture anchor being coupled to the introducer so that the distal end is exposed, the distal end being configured to penetrate the bone to form a hole from the surface of the bone to a desired depth, the hole having a sidewall, the proximal end of the suture anchor being configured to penetrate the sidewall of the hole upon application of tension to the suture.
2. The suture anchor assembly of claim 1, wherein:  
the suture anchor is configured to tilt within the hole upon application of tension to the suture.
3. The suture anchor assembly of claim 2, wherein:  
the suture anchor tilts within the hole so that the distal end engages the sidewall opposite a portion of the sidewall that the proximal end penetrates.
4. The suture anchor assembly of claim 1, wherein:  
the suture anchor has a maximum outer transverse dimension; and  
a plurality of sutures each having a nominal USP diameter;  
wherein a total sum cross sectional area of the plurality of sutures attached to the anchor is more than 20% of the maximum cross sectional area of the anchor, the cross sectional area of the suture defined by the nominal USP diameter of the suture.
5. The suture anchor assembly of claim 1, wherein:  
the suture anchor is formed so the proximal and distal ends are formed from a single piece of material.
6. The suture anchor assembly of claim 1, wherein:

the suture anchor has no movable or deformable parts.

7. The suture anchor assembly of claim 1, wherein:  
the suture anchor has no movable or deformable parts which engage bone.
8. The suture anchor assembly of claim 1, wherein:  
the suture anchor has a shoulder positioned at a transition between the distal portion and the proximal portion,
9. The suture anchor assembly of claim 1, wherein:  
the distal portion of the suture anchor includes a recess sized to receive the suture.
10. The suture anchor assembly of claim 9, wherein:  
the suture anchor includes a suture channel which extends along the proximal portion of the suture anchor, the suture channel communicating with the recess so that the suture may extend through the suture channel while the suture is positioned in the recess, the suture channel providing passage for the suture while the anchor is coupled to the introducer.
11. The suture anchor assembly of claim 10, wherein:  
the suture channel is eccentrically positioned along the proximal portion of the suture anchor so that an eccentric force is applied to the suture anchor when suture positioned in the suture channel is tensioned, the eccentric force being eccentric to a central axis of the suture anchor.
12. The suture anchor assembly of claim 10, wherein:  
the suture channel includes a slot, the slot permitting the suture to enter and leave the suture channel.
13. The suture anchor assembly of claim 9, wherein:  
the recess is sized to receive an enlargement of the suture.



14. The suture anchor assembly of claim 1, wherein:  
the proximal portion tapers proximally from a shoulder to the proximal end, the shoulder being a transition between the proximal portion and the distal portion.
15. The suture anchor assembly of claim 14, wherein:  
the distal portion, the shoulder and the proximal portion are integrally formed.
16. The suture anchor assembly of claim 1, wherein:  
the introducer has a lumen containing only suture.
17. The suture anchor assembly of claim 16, wherein:  
the introducer has one lumen containing only the suture.
18. A suture anchor assembly, comprising:  
an introducer;  
a suture anchor coupled to the introducer, the suture anchor having a distal portion and a proximal portion, the distal portion having a distal end shaped to penetrate bone, the proximal portion having a proximal end also configured to penetrate bone, the suture anchor being coupled to the introducer so that the distal end is exposed, the distal end being configured to penetrate the bone to form a hole from the surface of the bone to a desired depth, the hole having a sidewall; and  
means for tilting the suture anchor within the hole after penetrating the bone with the suture anchor, the tilting means causing the proximal end to penetrate the sidewall of the hole on a side opposite the sidewall where the distal end engages the sidewall.
19. The suture anchor assembly of claim 18, wherein:  
the tilting means includes a suture coupled to the suture anchor, wherein the suture anchor tilts within the hole upon application of tension to the suture.
20. The suture anchor assembly of claim 19, wherein:

the suture anchor has a maximum outer transverse dimension; and  
the suture has a nominal USP diameter;  
wherein the maximum outer transverse dimension of the anchor is no more than 4 times the nominal USP diameter of the suture.

21. The suture anchor assembly of claim 18, wherein:  
the proximal and distal ends of the suture anchor are formed integrally from a single piece of material.

22. The suture anchor assembly of claim 18, wherein:  
the suture anchor is formed so that all portions which engage bone are formed from the single piece of material.

23. The suture anchor assembly of claim 18, wherein:  
the suture anchor has no movable or deformable parts.

24. The suture anchor assembly of claim 18, wherein:  
the suture anchor has no movable or deformable parts which engage bone.

25. The suture anchor assembly of claim 18, wherein:  
the introducer covers the proximal end of the suture anchor when the suture anchor is coupled to the introducer, the proximal end being exposed when the introducer is removed; and  
the tilting means including a suture which is tensioned to move the proximal end of the anchor into contact with the sidewall of the hole.

26. The suture anchor assembly of claim 18, wherein:  
the suture anchor has a shoulder positioned at a transition between the distal portion and the proximal portion,

27. The suture anchor assembly of claim 18, wherein:

the distal portion of the suture anchor includes a recess sized to receive the suture.

28. The suture anchor assembly of claim 27, wherein:  
the suture anchor includes a suture channel which extends through the proximal portion, the suture channel communicating with the recess so that the suture may extend through the suture channel while the suture is positioned in the recess.
29. The suture anchor assembly of claim 28, wherein:  
the suture channel is eccentrically positioned so that an eccentric force is applied to the suture anchor when suture positioned in the suture channel is tensioned.
30. The suture anchor assembly of claim 28, wherein:  
the suture channel includes a slot, the slot permitting suture to enter and leave the suture channel.
31. The suture anchor assembly of claim 27, wherein:  
the recess is sized to receive an enlargement on the suture.
32. The suture anchor assembly of claim 18, wherein:  
the proximal portion tapers proximally from a shoulder to the proximal end, the shoulder being a transition between the proximal portion and the distal portion.
33. The suture anchor assembly of claim 32, wherein:  
the distal portion, the shoulder and the proximal portion are integrally formed.
34. The suture anchor assembly of claim 18, wherein:  
the introducer has a lumen containing only the suture.
35. The suture anchor assembly of claim 34, wherein:  
the introducer has one lumen containing only the suture.

36. A method of installing a suture anchor, comprising the steps of:  
providing a suture anchor having a proximal end and a distal end, the suture anchor being mounted to an introducer;  
driving the suture anchor into a surface of a bone to form a hole in the bone, the hole having a sidewall and a longitudinal axis, the hole defining a transverse axis which is perpendicular to the longitudinal axis;  
applying a force to the suture anchor which tilts the suture anchor within the hole and causes the proximal end of the suture anchor to penetrate the sidewall of the hole.
37. The method of claim 36, wherein:  
the applying step is carried out by tensioning a suture which is coupled to the suture anchor.
38. The method of claim 36, wherein:  
the applying step is carried out so that the distal end of the anchor also penetrates the sidewall of the hole, the proximal end of the suture anchor penetrating the sidewall on an opposite side of the sidewall from where the distal end penetrates the sidewall of the hole.
39. The method of claim 36, wherein:  
the driving step is carried out so that the anchor is impacted in the hole when the driving step is completed.
40. The method of claim 36, wherein:  
the providing step is carried out with the anchor having no movable or deformable parts.
41. The method of claim 36, wherein:  
the suture anchor has no movable or deformable parts which engage bone.

42. The method of claim 36, wherein:  
the driving step is carried out with the distal end of the suture anchor penetrating a surface of the bone.
43. The method of claim 36, further comprising the step of:  
removing the introducer.
44. The method of claim 36, wherein:  
the removing step exposes the proximal end of the suture anchor; and  
the applying step moves the proximal end of the anchor into contact with the sidewall of the hole.
45. The method of claim 36, wherein:  
the applying step is carried out with at least part of a midsection intersects the sidewall, the midsection being a cross-section of the suture anchor positioned midway between the proximal end and the distal end.
46. The method of claim 36, wherein:  
the applying step is carried out with the proximal end of the suture anchor penetrating a transverse distance into the sidewall which is at least three times more than a transverse distance that the distal end penetrates into the sidewall.
47. The method of claim 36, wherein:  
the providing step is carried out by providing an introducer having a distal end, the suture anchor having a shoulder with the distal end of the introducer contacting the shoulder, a portion of the shoulder penetrating the sidewall on a same side of the sidewall that the proximal end of the suture anchor penetrates the sidewall
48. The method of claim 36, wherein:  
the driving step is carried out so that the anchor is impacted in the hole.

49. The method of claim 36, wherein:  
the applying step is completed with the suture anchor tilting no more than 45 degrees.
50. The method of claim 36, wherein:  
the driving step is carried out with the anchor being driven into a pilot hole which is smaller than the anchor so that the anchor forms the hole which is larger than the pilot hole.
51. A method of installing a suture anchor, comprising the steps of:  
providing a suture anchor having a proximal end and a distal end which define a length of the suture anchor;  
driving the suture anchor into bone to form a hole in a bone with the distal end of the suture anchor, the hole having a sidewall and a longitudinal axis, the hole defining a transverse axis which is perpendicular to the longitudinal axis;  
applying a force to the suture anchor which displaces the suture anchor proximally within the hole, the proximal end of the suture anchor penetrating the sidewall of the hole.
52. The method of claim 51, wherein:  
the driving step is carried out with the suture anchor being driven into the bone from the surface of the bone.
53. The method of claim 51, wherein:  
the applying step is carried out so that the distal end of the anchor also engages the sidewall of the hole, the proximal end of the suture anchor penetrating the sidewall on an opposite side of the sidewall from where the distal end engages the sidewall of the hole.
54. The method of claim 51, wherein:

the applying step is carried out with at least part of a midsection intersecting the sidewall, the midsection being a cross-section of the suture anchor midway between the proximal end and the distal end.

55. The method of claim 51, wherein:

the applying step is carried out with the proximal end of the suture anchor penetrating a transverse distance into the sidewall which is at least three times more than a transverse distance that the distal end penetrates into the sidewall.

56. The method of claim 51, wherein:

the providing step is carried out by providing an introducer having a distal end, the suture anchor having a shoulder with the distal end of the introducer contacting the shoulder, a portion of the shoulder penetrating the sidewall on a same side of the sidewall that the proximal end of the suture anchor penetrates the sidewall.

57. The method of claim 51, wherein:

the driving step is carried out so that the anchor is impacted in the hole.

58. The method of claim 51, wherein:

the applying step is initiated while substantially only frictional engagement between the anchor and the hole resists the force applied to the suture anchor.

59. The method of claim 51, wherein:

the providing step is carried out with the anchor having no movable or deformable parts which engage bone.

60. The suture anchor of claim 51, wherein:

the applying step is carried out so that the suture anchor tilts no more than 45 degrees.

61. The method of claim 51, wherein:

the driving step is carried out with the anchor being driven into a pilot hole so that the anchor forms the hole beyond the pilot hole.

62. The method of claim 51, wherein:  
the providing step is carried out with the suture anchor being coupled to an introducer, the suture anchor being positioned at a distal end of the introducer.

63. The method of claim 62, wherein:  
the providing step is carried out with the introducer having a lumen.

64. The method of claim 62, wherein:  
the providing step is carried out with the lumen of the introducer containing nothing except suture.

65. The method of claim 62, wherein:  
the providing step is carried out with the suture anchor having a shoulder which contacts a distal end of the introducer; and  
the driving step being carried out with the force being applied to the introducer and transmitted to the shoulder of the suture anchor.

66. The method of claim 62, wherein:  
the providing step is carried out with the suture being positioned outside the introducer.

67. The method of claim 62, wherein:  
the providing step is carried out with the introducer having a groove on an outer surface which receives suture.

68. The method of claim 62, further comprising the step of:  
removing the introducer.



69. The method of claim 68, wherein:  
the removing step exposes the proximal end of the suture anchor; and  
the applying step moves the proximal end of the anchor into contact with the sidewall of the hole.
70. The method of claim 51, wherein:  
the driving step is carried out while rotating the suture anchor by rotating the introducer.
71. The method of claim 51, wherein:  
the driving step is carried out so that the suture anchor is impacted within the hole when the driving step is completed.
72. A suture anchor, comprising:  
a distal portion having a distal end, the distal end having a first sharp tip;  
a proximal portion having a proximal end, the proximal end having a second sharp tip to penetrate bone which is configured to penetrate bone more easily than the first sharp tip; and  
a shoulder positioned at a transition between the distal portion and the proximal portion.
73. The suture anchor of claim 72, wherein:  
the distal portion includes a recess sized to receive suture.
74. The suture anchor of claim 73, further comprising:  
a suture channel which extends through the proximal portion, the suture channel communicating with the recess so that the suture may extend through the suture channel while the suture is positioned in the recess.
75. The suture anchor of claim 74, wherein:

the suture channel is eccentrically positioned so that an eccentric force is applied to the anchor when suture positioned in the suture channel is tensioned.

76. The suture anchor of claim 74, wherein:  
the suture channel includes a slot, the slot permitting suture to enter and leave the suture channel.

77. The suture anchor of claim 73, wherein:  
the recess is sized to receive an enlargement on the suture.

78. The suture anchor of claim 72, further comprising:  
a suture which extends into the distal portion of the anchor;  
the anchor having a maximum outer dimension;  
wherein a combined total cross sectional area of suture attached to the anchor is more than 20% of the maximum cross sectional area of the anchor, the cross sectional area of the suture defined by the nominal USP diameter of the suture.

79. The suture anchor of claim 72, wherein:  
the proximal portion tapers proximally from the shoulder to the proximal end.

80. The suture anchor of claim 72, wherein:  
the distal portion, the shoulder and the proximal portion are integrally formed.

81. The suture anchor of claim 72, further comprising:  
an introducer having a lumen; and  
a suture positioned within the lumen of the introducer;  
the shoulder contacting a distal end of the introducer.

82. The suture anchor of claim 81, wherein:  
the lumen of the introducer contains only the suture.

83. The suture anchor of claim 72, further comprising:  
an introducer;  
a suture positioned outside of the introducer; and  
the shoulder contacting a distal end of the introducer.
84. The suture anchor of claim 72, wherein:  
the distal portion does not include a threaded portion.
85. A method of installing a suture anchor, comprising the steps of:  
providing a suture anchor having a proximal end and a distal end which define a length of the suture anchor, the suture anchor having a midsection being a cross-section midway between the proximal and distal ends;  
positioning the suture anchor in a hole in a bone, the hole having a sidewall and a longitudinal axis, the hole defining a transverse axis which is perpendicular to the longitudinal axis;  
applying a force to the suture anchor which displaces the suture anchor proximally within the hole, the proximal end of the suture anchor penetrating into the sidewall of the hole, wherein at least part of the midsection of the suture anchor penetrates into the sidewall.
86. The method of claim 85, wherein:  
the applying step is carried out with the proximal end of the suture anchor penetrating a transverse distance into the sidewall which is at least three times more than a transverse distance that the distal end penetrates into the sidewall.
87. The method of claim 85, wherein:  
the applying step is carried out so that the distal end of the anchor also penetrates the sidewall of the hole on an opposite side of the sidewall from where the distal end penetrates the sidewall of the hole.
88. The method of claim 85, wherein:

the providing step is carried out with by providing an introducer having a distal end, the suture anchor having a shoulder with the distal end of the introducer contacting the shoulder; and

the applying step being carried out so that a portion of the shoulder penetrates the sidewall of the hole on a same side of the sidewall that the proximal end of the suture anchor penetrates the sidewall.

89. A method of installing a suture anchor, comprising the steps of:  
providing a suture anchor having a proximal end and a distal end which define a length of the suture anchor;

positioning the suture anchor in a hole in a bone, the hole having a sidewall and a longitudinal axis, the hole defining a transverse axis which is perpendicular to the longitudinal axis;

applying a force to the suture anchor which displaces the suture anchor proximally within the hole, the proximal end of the suture anchor penetrating into the sidewall of the hole, wherein the proximal end penetrates into the sidewall a distance which is at least three times further than a distance that the distal end penetrates the sidewall.

90. The method of claim 89, wherein:  
the applying step is carried out with the proximal end of the suture anchor penetrating a transverse distance into the sidewall which is at least three times more than a transverse distance that the distal end penetrates the sidewall.

91. The method of claim 89, wherein:  
the applying step is carried out with a midsection of the suture anchor intersecting the sidewall of the hole, the midsection being a cross-section midway between the proximal end and the distal end.

92. A method of installing a suture anchor, comprising the steps of:  
providing a suture anchor having a proximal end and a distal end which define a length of the suture anchor, the suture anchor having a suture coupled thereto, the anchor

having a maximum outer transverse dimension which is no more than four times the nominal USP diameter of the suture;

driving the suture anchor into bone to create a hole in a bone, the hole having a sidewall and a longitudinal axis, the hole defining a transverse axis which is perpendicular to the longitudinal axis;

applying a force to the suture anchor which displaces the suture anchor proximally within the hole, the proximal end of the suture anchor being driven into the sidewall of the hole.

93. The method of claim 92, wherein:  
the applying step is carried out with a midsection of the suture anchor intersecting the sidewall of the hole, the midsection being a cross-section midway between the proximal end and the distal end.

94. The method of claim 92, wherein:  
the applying step is carried out with the proximal end of the suture anchor being driven a transverse distance into the sidewall which is at least three times more than a transverse distance that the distal end is driven into the sidewall.

95. The method of claim 92, wherein:  
the providing step is carried out by providing an introducer having a distal end, the suture anchor having a shoulder with the distal end of the introducer contacting the shoulder;  
the applying step being carried out so that a portion of the shoulder penetrates the sidewall of the hole on a same side of the sidewall that the proximal end of the suture anchor penetrates the sidewall.

96. The method of claim 92, wherein:  
the driving step is carried out so that the anchor is impacted at the bottom of the hole.

97. The method of claim 92, wherein:  
the driving step is carried out with the anchor being driven into a pilot hole so that the anchor forms the hole beyond the pilot hole.
98. The method of claim 92, wherein:  
the providing step is carried out with the maximum outer transverse dimension of the anchor being no more than 0.080 inch.
99. The method of claim 92, wherein:  
the providing step is carried out with the suture anchor being coupled to an introducer having a lumen, the lumen containing nothing except the suture.
100. A method of installing a suture anchor, comprising the steps of:  
providing a suture anchor having a proximal end and a distal end and a midsection positioned midway between the proximal and distal ends, the midsection being a cross section extending transversely through the suture anchor;  
positioning the suture anchor in a hole in a bone, the hole having a sidewall, the hole having a longitudinal axis, the hole defining a transverse axis which is perpendicular to the longitudinal axis;  
applying a force to the suture anchor which displaces the suture anchor proximally within the hole, the proximal end of the suture anchor penetrating the sidewall so that at least part of the midsection penetrates the sidewall of the hole.
101. A suture anchor; comprising:  
an anchor;  
an introducer, the anchor being coupled to the introducer;  
a suture attached to the anchor, the suture being tensioned to tilt the anchor within a hole formed by the anchor;  
the anchor including a distal portion and a proximal portion, separated by a shoulder, the distal portion shaped to penetrate bone and make the hole in the bone, the distal portion adjacent to the shoulder having a transverse dimension measuring a full diameter of

the hole, the distal portion adjacent to the shoulder being configured to engage the sidewall of the hole across the entire transverse dimension of the hole, the proximal portion having a sharp tip oriented such that it will engage and penetrate the sidewall of the hole as the anchor tilts and moves in a retrograde direction, the proximal portion having a lesser maximum transverse dimension than the distal portion.

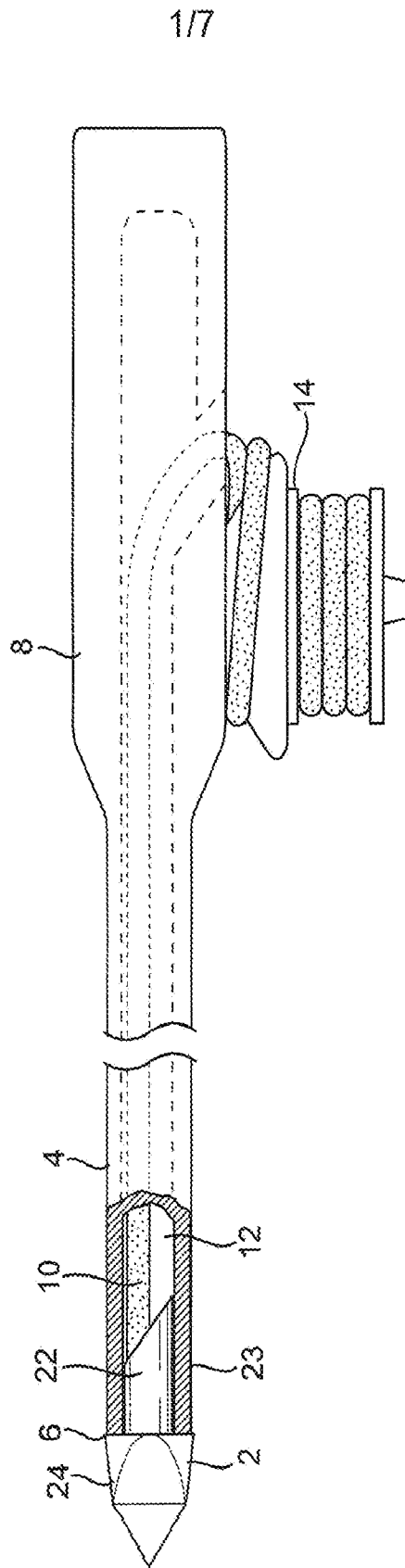

FIG. 1



2/7

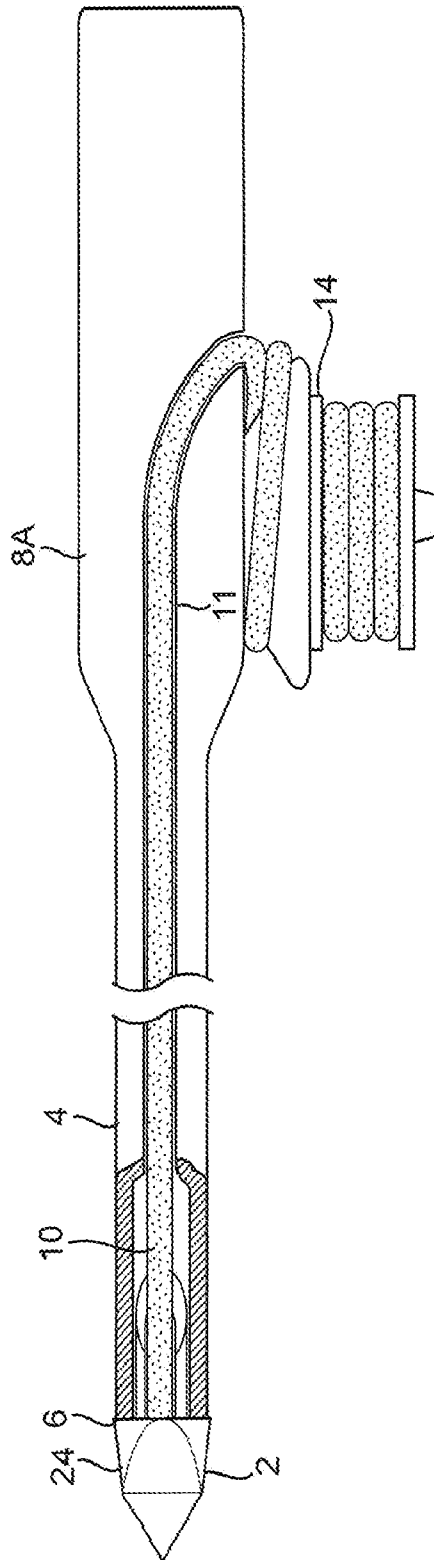

FIG. 2

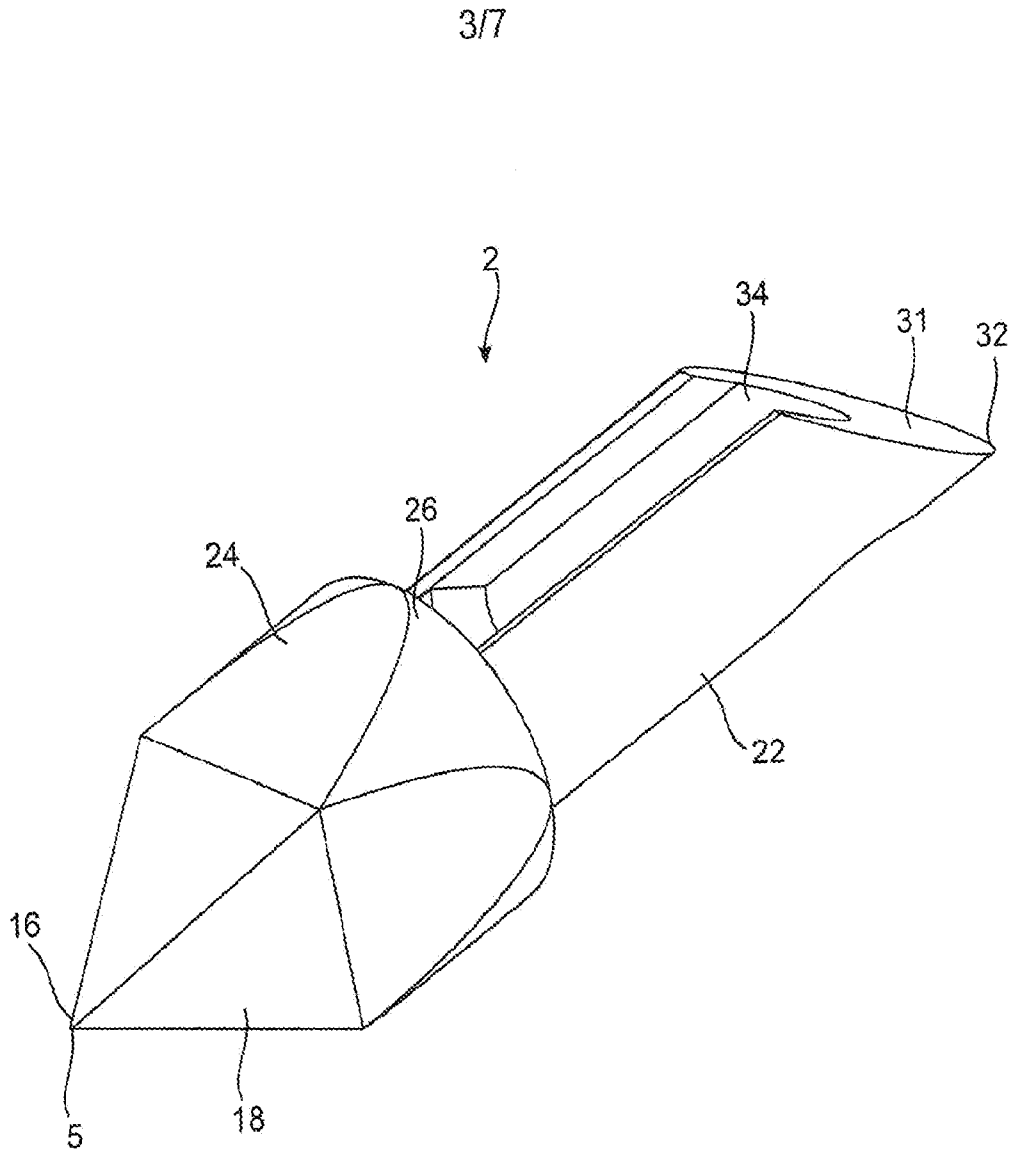
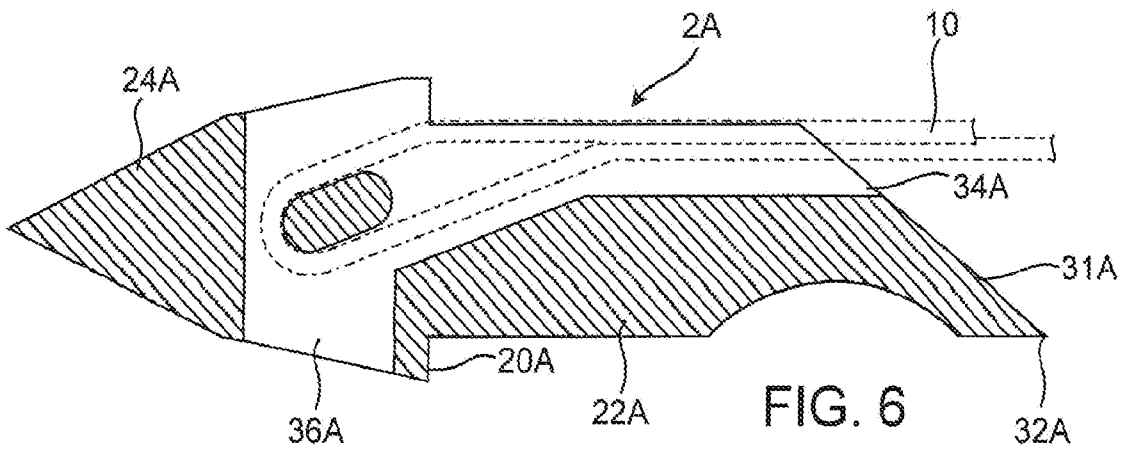
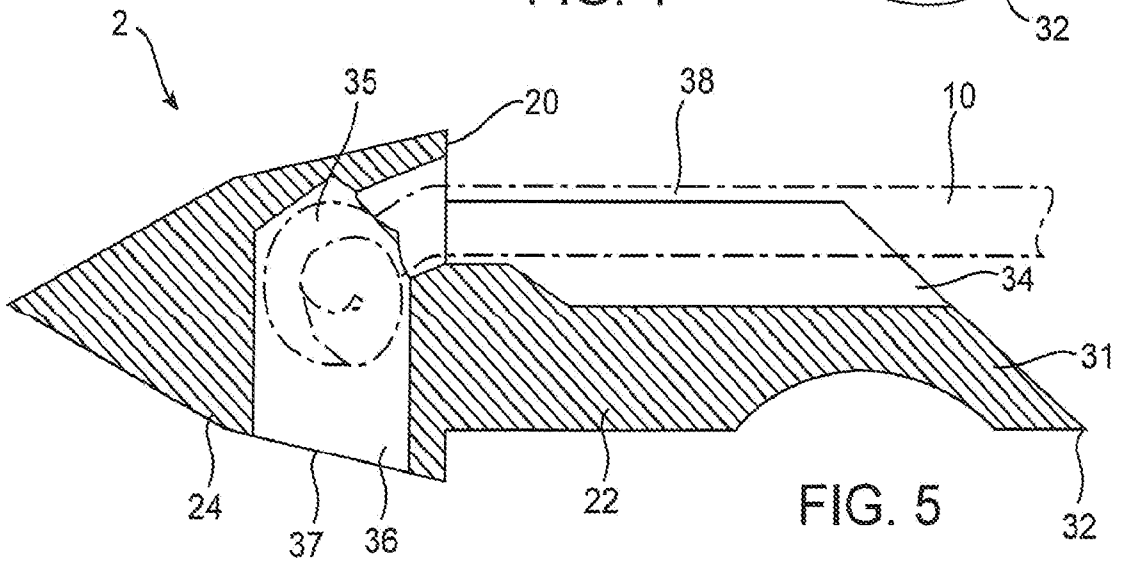
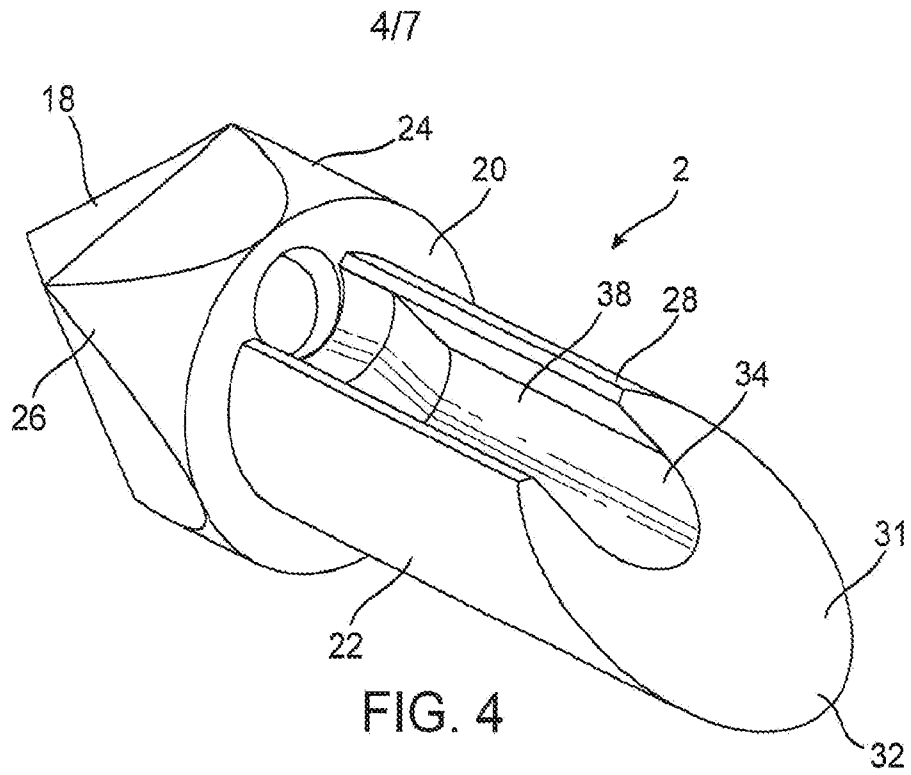

FIG. 3



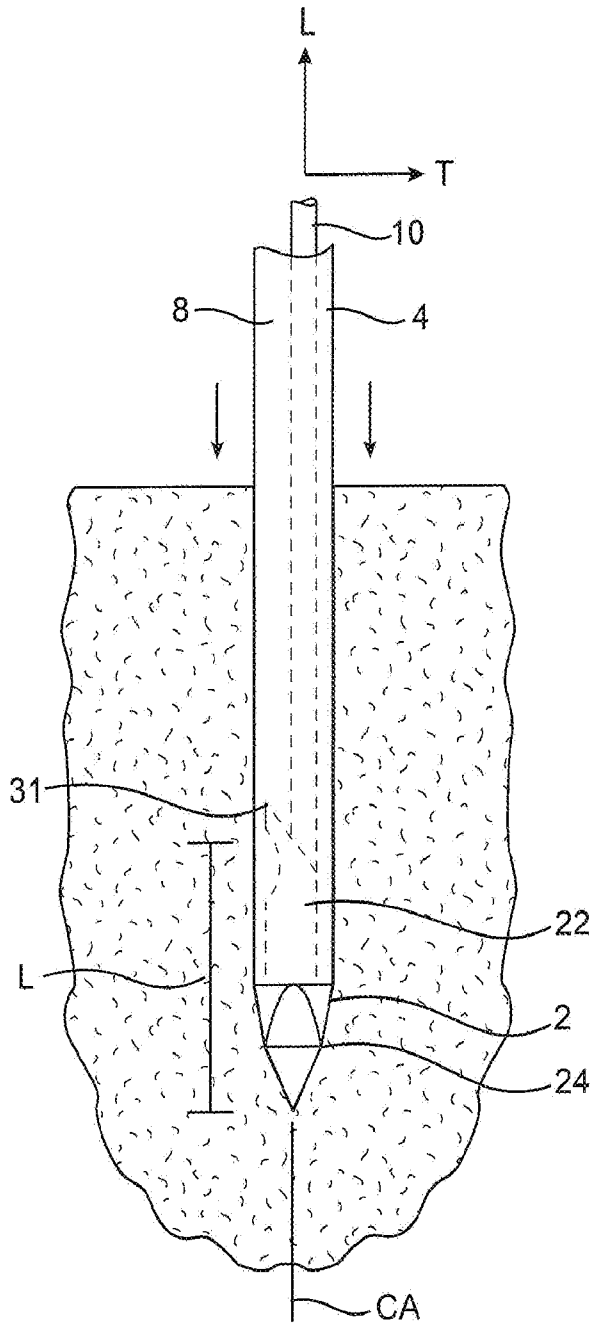

FIG. 7

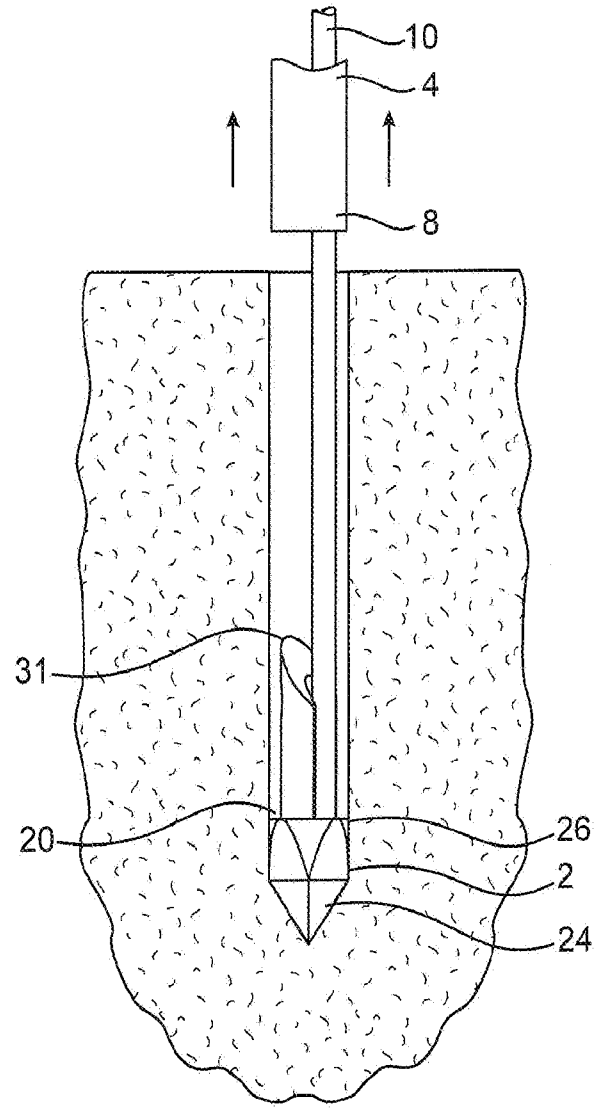

FIG. 8

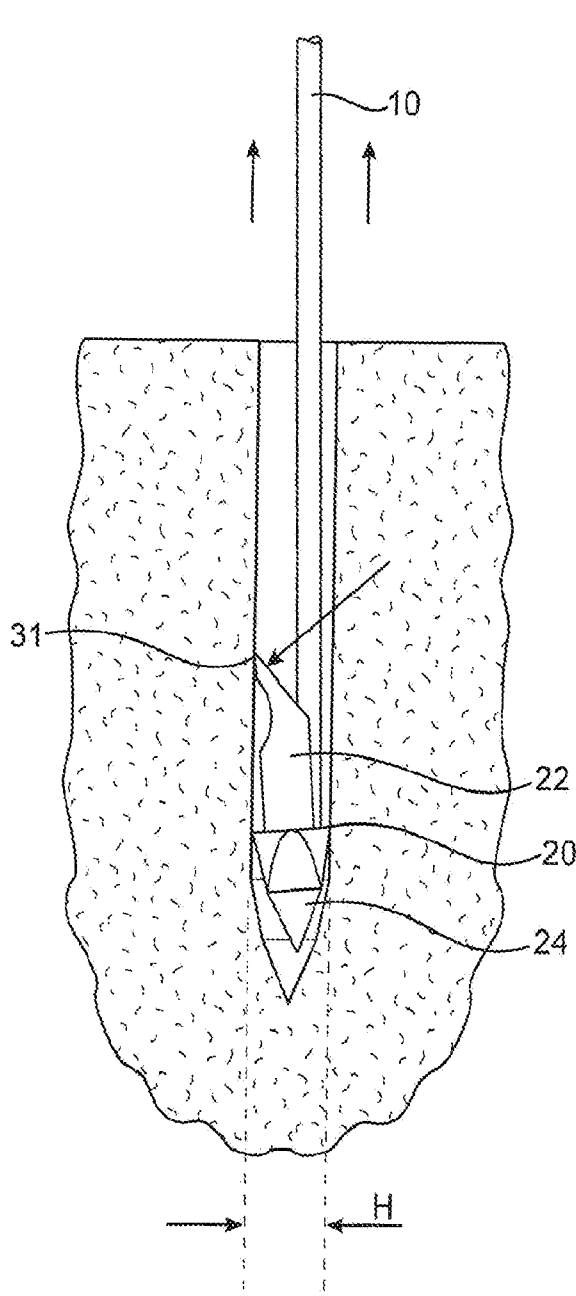

FIG. 9

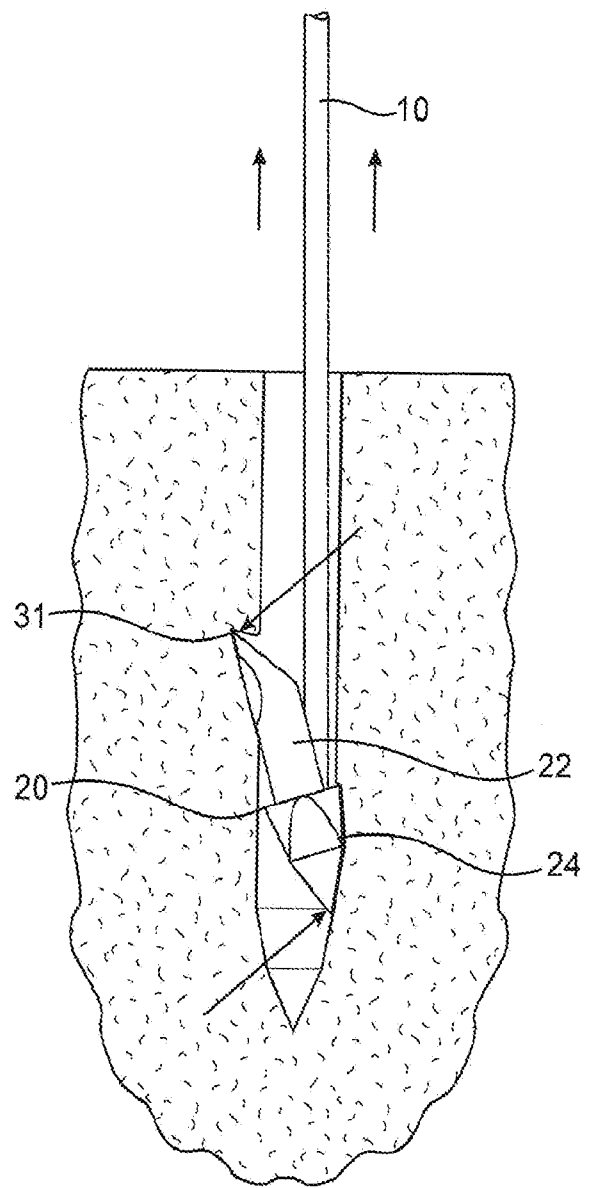

FIG. 10

7/7

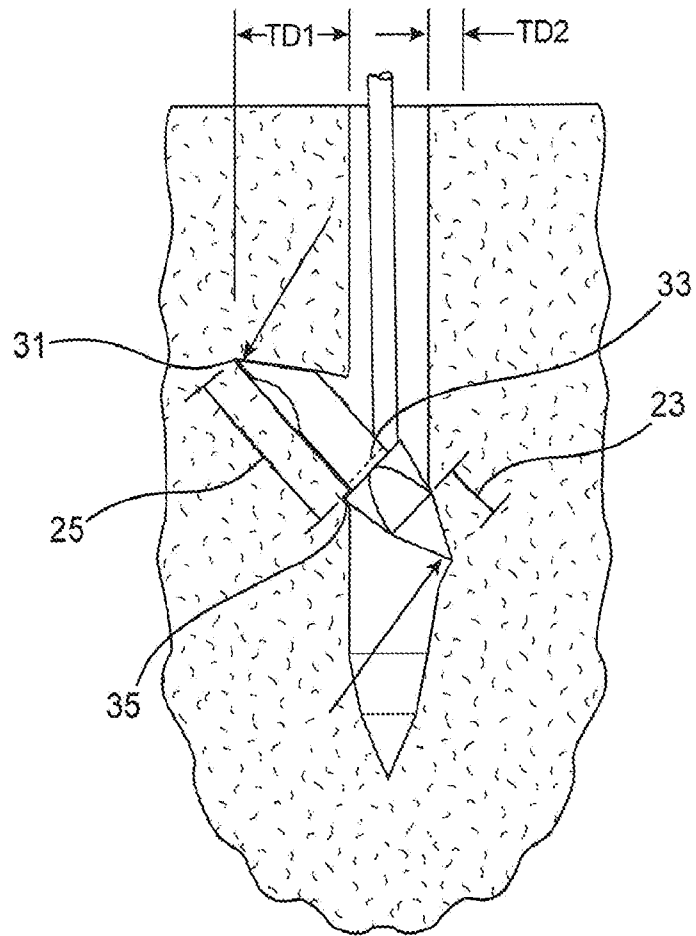

FIG. 11

**INTERNATIONAL SEARCH REPORT**

International application No.  
PCT/US2012/021891

**A. CLASSIFICATION OF SUBJECT MATTER**  
 IPC(8) - A61B 17/04 (2012.01)  
 USPC - 606/232  
 According to International Patent Classification (IPC) or to both national classification and IPC

**B. FIELDS SEARCHED**

Minimum documentation searched (classification system followed by classification symbols)  
 IPC(8) - A61B 17/04 (2012.01)  
 USPC - 606/104, 232, 323

Documentation searched other than minimum documentation to the extent that such documents are included in the fields searched

Electronic data base consulted during the international search (name of data base and, where practicable, search terms used)  
 PatBase and Google Patents

**C. DOCUMENTS CONSIDERED TO BE RELEVANT**

Category*	Citation of document, with indication, where appropriate, of the relevant passages	Relevant to claim No.
X	US 5,527,342 A (PIETRZAK et al) 18 June 1996 (18.06.1996) entire document	1-8, 18-26, 36-49, 51-60, 62, 65-72, 80, 83-84, 92-96, 98, 101
-		
Y		9-17, 27-35, 50, 61, 63-64, 73-79, 81-82, 85-91, 97, 99-100
Y	US 2007/0225719 A1 (STONE et al) 27 September 2007 (27.09.2007) entire document	9-13, 27-31, 73-77
Y	US 2009/0088797 A1 (CROMBIE et al) 02 April 2009 (02.04.2009) entire document	14-15, 32-33, 79
Y	US 2004/0254580 A1 (BOOCK et al) 16 December 2004 (16.12.2004) entire document	16-17, 34-35, 63, 64, 81-82, 99
Y	US 6,096,060 A (FITTS et al) 01 August 2000 (01.08.2000) entire document	50, 61, 85-91, 97, 100
Y	US 6,645,227 B2 (FALLIN et al) 11 November 2003 (11.11.2003) entire document	78

Further documents are listed in the continuation of Box C.

* Special categories of cited documents:	"T" later document published after the international filing date or priority date and not in conflict with the application but cited to understand the principle or theory underlying the invention
"A" document defining the general state of the art which is not considered to be of particular relevance	"X" document of particular relevance; the claimed invention cannot be considered novel or cannot be considered to involve an inventive step when the document is taken alone
"E" earlier application or patent but published on or after the international filing date	"Y" document of particular relevance; the claimed invention cannot be considered to involve an inventive step when the document is combined with one or more other such documents, such combination being obvious to a person skilled in the art
"L" document which may throw doubts on priority claim(s) or which is cited to establish the publication date of another citation or other special reason (as specified)	"&" document member of the same patent family
"O" document referring to an oral disclosure, use, exhibition or other means	
"P" document published prior to the international filing date but later than the priority date claimed	

Date of the actual completion of the international search 11 May 2012	Date of mailing of the international search report <b>23 MAY 2012</b>
Name and mailing address of the ISA/US Mail Stop PCT, Attn: ISA/US, Commissioner for Patents P.O. Box 1450, Alexandria, Virginia 22313-1450 Facsimile No. 571-273-3201	Authorized officer: Blaine R. Copenheaver  PCT Helpdesk: 571-272-4300 PCT OSP: 571-272-7774