

(19)



(11)

**EP 2 821 716 B1**

(12)

**EUROPEAN PATENT SPECIFICATION**

(45) Date of publication and mention of the grant of the patent:

**18.12.2019 Bulletin 2019/51**

(51) Int Cl.:

<b>F24F 1/00</b> <sup>(2019.01)</sup>	<b>F24F 13/08</b> <sup>(2006.01)</sup>
<b>F24F 1/0011</b> <sup>(2019.01)</sup>	<b>F24F 1/0014</b> <sup>(2019.01)</sup>
<b>F24F 13/06</b> <sup>(2006.01)</sup>	<b>F24F 1/0047</b> <sup>(2019.01)</sup>

(21) Application number: **14175399.6**

(22) Date of filing: **02.07.2014**

(54) **air conditioner indoor unit comprising a wind-visor for air discharge opening**

Inneneinheit einer Klimaanlage mit Windabweiser für den Luftauslass

climatiseur avec un écran pour détourner l'air

(84) Designated Contracting States:

**AL AT BE BG CH CY CZ DE DK EE ES FI FR GB GR HR HU IE IS IT LI LT LU LV MC MK MT NL NO PL PT RO RS SE SI SK SM TR**

(30) Priority: **02.07.2013 KR 20130077017**

(43) Date of publication of application:

**07.01.2015 Bulletin 2015/02**

(73) Proprietor: **LG Electronics Inc.**

**Seoul 150-721 (KR)**

(72) Inventors:

- **Jeong, Sangmoon**  
**153-802 Seoul (KR)**

- **Kim, Yong**  
**153-802 Seoul (KR)**
- **Kim, Myungshik**  
**153-802 Seoul (KR)**
- **Kwon, Huijae**  
**153-802 Seoul (KR)**

(74) Representative: **Vossius & Partner**  
**Patentanwälte Rechtsanwälte mbB**  
**Siebertstrasse 3**  
**81675 München (DE)**

(56) References cited:

<b>EP-A2- 1 701 100</b>	<b>WO-A1-2009/054316</b>
<b>JP-A- 2010 084 996</b>	<b>KR-A- 20120 111 822</b>
<b>US-A- 2 363 839</b>	<b>US-A1- 2010 190 432</b>

**EP 2 821 716 B1**

Note: Within nine months of the publication of the mention of the grant of the European patent in the European Patent Bulletin, any person may give notice to the European Patent Office of opposition to that patent, in accordance with the Implementing Regulations. Notice of opposition shall not be deemed to have been filed until the opposition fee has been paid. (Art. 99(1) European Patent Convention).

## Description

### BACKGROUND

**[0001]** The present disclosure relates to a wind-visor and an air conditioner including the same.

**[0002]** Air conditioners are cooling/heating appliances for cooling or heating an indoor space through heat-exchange between indoor/outdoor air and a refrigerant. Air conditioners installed for maintaining pleasant indoor air in buildings may be classified into wall mount type air conditioners installed at a predetermined height on a wall, stand type air conditioners standing up in an indoor space, and ceiling type air conditioners installed on a ceiling.

**[0003]** Among these, the ceiling type air conditioners installed on a ceiling may be mainly installed in places, which are utilized by many peoples and make better use of a space, such as offices, classrooms, public offices, and the like. Such a ceiling type air conditioner has an inflow hole that is defined in a central portion of the air conditioner to introduce indoor air and a discharge hole that is defined outside the inflow hole to discharge conditioned air in all directions.

**[0004]** A cover is disposed on the discharge hole. Thus, when the air conditioner is turned off, the cover may cover the discharge hole to prevent foreign substances from being introduced into the air conditioner. When the air conditioner is turned on, the cover may be opened to open the discharge hole, thereby discharging the conditioned air into an indoor space. Here, the cover may rotate on a side of the discharge hole to switch a discharge direction of air.

**[0005]** In the ceiling type air conditioners according to the related art, the cover may not have a sufficient size. For example, the cover may have a size equal or similar to that of the discharge hole. In this case, when the cover rotates in a state where the cover opens the discharge hole, it may be difficult to uniformly discharge air in various directions, and thus, the air may be concentrated into a specific position.

**[0006]** As a result, if a user stays for a long time at the position of the indoor space into which the air is concentrated, the user may feel inconvenience or displeasure. For example, when the discharged air is cold air, hypothermia in which a temperature of the human body has gone down may occur, or the person may get sick from overexposure to air conditioning. On the other hand, the conditioned air may not be sufficiently supplied into positions spaced apart from the position into which the air is concentrated to deteriorate reliability of the air conditioner.

**[0007]** To solve the above-described limitation, Korean Patent Publication No. 10-2012-011822 discloses a wind guide device that is mounted and fixed to a front panel of the air conditioner by using a screw.

**[0008]** Particularly, the wind guide device includes a guide plate including a flat plate installed in a longitudinal

direction of the discharge hole and a long hole defined in each of both sides of the plate in parallel to the longitudinal direction of the discharge hole, a main body including a body installed on a side surface of the discharge hole and having a predetermined length, a coupling piece protruding from each of both lower ends of the body, and a guide surface disposed on a lower end of the coupling piece and having a semicircular shape, a rotation body inserted into an insertion groove defined between the coupling pieces of the main body and including a coupling screw disposed on a lower end thereof to protrude so that the coupling screw is inserted into the long hole of the guide plate, and a support body allowing the guide plate to be closely attached to the guide surface and having a screw hole coupled to the coupling screw.

**[0009]** However, in the case of the wind guide device according to the related art, since a plurality of components are provided, the wind guide device may have a complex structure. In addition, at least one portion of the plurality of components may fall down to cause safety accident due to a weight of each of the plurality of components.

**[0010]** For this, when the components are strongly fixed by using screws or adhesion material so as to prevent the components from falling down, it may be difficult to attach or detach the components. Also, after the components are separated, punched holes or the adhesion material may remain at the positions, at which the components are separated, to deteriorate an exterior of the air conditioner.

**[0011]** Also, since a hole has to be punched in an installation surface of the air conditioner, the air conditioner may be reduced in durability.

**[0012]** Also, an air backflow phenomenon in which the air discharged from the discharge hole is reflected by the guide plate to return to an air suction hole of the air conditioner may occur. JP 2010 084996 discloses another air conditioner of the ceiling-mounted type with a front panel comprising a suction hole and a wind-visor detachably disposed on a side of the discharge hole. The wind-visor is movable and serves thereby at the same time as a discharge louver.

### SUMMARY

**[0013]** Embodiments provides a wind-visor that is capable of preventing hot or warm air from being concentrated into a specific area to efficiently condition indoor air and an air conditioner including the same.

**[0014]** According to the present invention there is proposed an air conditioner as defined in claim 1. In one embodiment, an air conditioner including: a main body including a blower fan generating an air flow and a heat exchanger that is heat-exchanged with air flowing by the blower fan; a front panel including a suction hole through which the air introduced into the blower fan is suctioned and a discharge hole through which the air heat-exchanged in the heat exchanger is discharged; and a wind-

visor detachably disposed on a side of the discharge hole.

**[0015]** The wind-visor may be disposed between the discharge hole and the suction hole.

**[0016]** The wind-visor may be separably coupled to the front panel.

**[0017]** The air conditioner may further include: a first magnet disposed on the wind-visor; and a second magnet disposed on the front panel, the second magnet being selectively coupled to the first magnet.

**[0018]** The air conditioner may further include: a second installation groove defined in the front panel so that the second magnet is disposed therein, the second installation groove being defined between the discharge hole and the suction hole.

**[0019]** The wind-visor may be coupled to a front surface of the front panel, and the second installation groove may be recessed from a back surface of the front panel.

**[0020]** The wind-visor may include: a coupling part selectively coupled to a front side of the front panel; and a guide part extending from the coupling part to guide the air discharged from the discharge hole in a direction away from the suction hole.

**[0021]** The guide part may include: a blocking portion overlapping with the discharge hole at a front side of the discharge hole; and an extension portion extending from the blocking portion without overlapping with the discharge hole at the front side of the discharge hole.

**[0022]** The front panel may include a first edge and a second edge, which define the discharge hole, and a first virtual line (11) extending forward from the first edge and a second virtual line (12) extending forward from the second edge may meet a front portion or front surface of the wind-visor.

**[0023]** The second virtual line (12) may define a reference line for distinguishing the coupling part and guide part of the wind-visor from each other.

**[0024]** The coupling part may include: a first magnet selectively coupled to a second magnet of the front panel; and a first installation groove in which the first magnet is disposed.

**[0025]** The coupling part may include: a plurality of hollows; and at least one support rib for partitioning the plurality of hollows.

**[0026]** At least one hollow of the plurality of hollows may include the first installation groove.

**[0027]** The coupling part may have a cross-section that gradually decreases in width from the front panel toward the guide part.

**[0028]** The air conditioner further includes a discharge louver disposed in the discharge hole to adjust an opened degree of the discharge hole, wherein the wind-visor is coupled to a side of the discharge louver to guide discharge of the air through the discharge hole.

**[0029]** In another embodiment, a wind-visor disposed on a side of a front panel including a suction hole through which air is suctioned, a discharge hole through which air is discharged, and a discharge louver rotatably disposed on the discharge hole includes: a guide part in-

cluding a blocking portion that overlaps with the discharge hole and an extension portion that does not overlap with the discharge hole; and a coupling part extending from the guide part, the coupling part being detachably disposed on a side of the discharge hole.

**[0030]** The wind-visor may further include a first magnet selectively coupled to a second magnet of the front panel.

**[0031]** The coupling part may be coupled to a front portion of the front panel, and a surface extending forward from a first edge of the discharge hole may define one surface of the coupling part.

**[0032]** A virtual line extending forward from a second edge of the discharge hole may be a reference line for partitioning the blocking portion from the extension portion.

**[0033]** The coupling part may include: a plurality of hollows having a first installation groove in which the first magnet is disposed; and at least one support rib for partitioning the plurality of hollows.

**[0034]** The details of one or more embodiments are set forth in the accompanying drawings and the description below. Other features will be apparent from the description and drawings, and from the claims.

## **BRIEF DESCRIPTION OF THE DRAWINGS**

### **[0035]**

Fig. 1 is a perspective view of an air conditioner according to an embodiment.

Fig. 2 is a bottom view of the air conditioner according to an embodiment.

Fig. 3 is a cross-sectional view taken along line I-I' of Fig. 1.

Fig. 4 is an enlarged view illustrating a portion A of Fig. 3.

Fig. 5 is a top view of a wind-visor according to an embodiment.

## **DETAILED DESCRIPTION OF THE EMBODIMENTS**

**[0036]** Hereinafter, preferred embodiments of the present disclosure will be described in detail with reference to the accompanying drawings in such a manner that the technical idea of the present disclosure may easily be carried out by a person with ordinary skill in the art to which the invention pertains. Moreover, detailed descriptions related to well-known functions or configurations will be ruled out in order not to unnecessarily obscure subject matters of the present invention. Also, portions having similar function and effect may be expressed with the same or similar reference symbol throughout.

**[0037]** In addition, in this disclosure below, when one part (or element, device, etc.) is referred to as being 'connected' to another part (or element, device, etc.), it should be understood that the former can be 'directly connected' to the latter, or 'electrically connected' to the latter via an

intervening part (or element, device, etc.). Furthermore, when it is described that one comprises (or includes or has) some elements, it should be understood that it may comprise (or include or has) only those elements, or it may comprise (or include or have) other elements as well as those elements if there is no specific limitation.

**[0038]** The air conditioner according to an embodiment may be a split type air conditioner in which an indoor unit and an outdoor unit are separated from each other. Also, a ceiling type indoor unit may be described as an example. However, the ideas of the present disclosure is not limited to the above-described structure. For example, the ideas of the present disclosure may also be applied to integrated air conditioner, wall mount type air conditioner, or stand type air conditioners.

**[0039]** Fig. 1 is a perspective view of an air conditioner according to an embodiment, Fig. 2 is a bottom view of the air conditioner according to an embodiment, Fig. 3 is a cross-sectional view taken along line I-I' of Fig. 1, and Fig. 4 is an enlarged view illustrating a portion A of Fig. 3.

**[0040]** Referring to Figs. 1 to 4, an air conditioner 10 according to an embodiment includes a casing 100 in which a plurality of components for air-conditioning are built, a front panel 110 disposed on a front surface of the casing 100, and a wind-visor 200 disposed on a side of the front panel 110.

**[0041]** The air conditioner 10 is buried in a ceiling. In this specification, a direction from the ceiling toward an indoor space may be defined as a "front direction", and a direction from the indoor space toward the ceiling may be defined as a "rear direction".

**[0042]** A heat exchanger 120 in which a refrigerant flows to heat-exchange with surrounding air, a blower fan 130 disposed on a side of the heat exchanger 120, a blower motor 140 for driving the blower fan 130, and a filter part for filtering foreign substances contained in air flowing into the casing 100 may be installed in the casing 100.

**[0043]** The heat exchanger 120 may be disposed to surround the periphery of the blower fan 130. However, the heat exchanger 120 according to the current embodiment is not limited in position or shape.

**[0044]** The blower fan 130 includes a turbo fan that introduces air in an axis direction thereof to discharge the air in a direction crossing the axis direction, e.g., a radius direction. The blower fan 130 may be disposed at an inner central portion of the casing 100. However, the blower fan 130 according to the current embodiment is not limited to kind or position.

**[0045]** The filter part 150 may be disposed at one point of a flow path of air that forcibly flows by the blower fan 130. For example, the filter part 150 may be disposed between the blower fan 130 and the front panel 110. That is, the filter part 150 may be disposed at a rear side of the front panel 110 to remove foreign substances contained in air that is introduced into the blower fan 130. Also, unlike the drawings, the filter part 150 may be disposed on a side surface of the heat exchanger 120 or a

side of a discharge part of the air conditioner 10. However, the filter part 150 according to the current embodiment is not limited to position or shape.

**[0046]** The front panel 110 is disposed on a front side of the casing 100. A central portion 110a protruding outward, i.e., forward may be disposed on the front panel 110. That is, the central portion 110a has a curved surface with a predetermined curvature. Thus, as illustrated in Fig. 3, the front panel 110 has a curved surface in cross-section. However, it is not necessary that the front panel 110 includes the protruding portion. Unlike the drawings, the front panel 110 may have a flat plate shape.

**[0047]** The front panel includes a suction hole 111 for suctioning indoor air, a front grill 112 disposed on the suction hole 110 to prevent foreign substances having relatively large volume from being introduced, a discharge hole 113 that is opened in a side of the suction hole 110 to discharge air, a discharge louver 114 for selectively opening or closing the discharge hole, and a wind-visor 200 disposed on a side of the discharge hole 113.

**[0048]** The suction hole 111 may be defined in the central portion 110a of the front panel 110. For example, the suction hole 110 may be defined in the protruding central portion 110a of the front panel 110.

**[0049]** The front grill 112 may be disposed on the suction hole 111 to filter foreign substances contained in air passing through the suction hole 111. For example, the front grill 112 may include a plurality of ribs coupled to each other to form a lattice pattern.

**[0050]** At least one discharge hole 113 may be defined in an edge of the front panel 110. In detail, the discharge hole 113 may be spaced apart outward from the suction hole 111. Also, the discharge hole 113 may be provided in plurality along the edge of the front panel 110.

**[0051]** For example, if the front grill 112 has a square shape, four discharge holes 113 may be provided to correspond to four sides of the front grill 112. Also, the discharge hole 113 may be defined in the protruding curved surface of the central portion 110a.

**[0052]** The discharge hole 113 may be defined in a direction in which the discharge hole 113 is inclined outward toward a front side of the front panel 110, i.e., inclined outward with respect to the ground. Thus, air discharged from the discharge hole 113 may be uniformly spread to the surrounding without being concentrated into a front side of the air conditioner 10.

**[0053]** The front panel 110 includes a first edge 113a and a second edge 113b, which define the discharge hole 113.

**[0054]** The first edge 113 may be disposed toward the inside of the front panel 110, and the second edge 113b may be disposed toward the outside of the front panel 110. The discharge hole 113 may be defined by a space between the first edge 113a and the second edge 113b.

**[0055]** The discharge louver 114 may be disposed in the discharge hole 113 to selectively open or close the discharge hole 113. The discharge louver 114 may be

rotatably connected to a rotation shaft. For example, the rotation shaft may extend in a direction perpendicular to a flow direction of the air discharged through the discharge hole 113 and be coupled to the front panel 110.

**[0056]** An opened degree of the discharge hole 113 may be determined according to a rotating angle of the discharge louver 114. When the discharge louver 114 is disposed in a direction parallel to the front panel 110 (a first position), the discharge hole 113 may be closed. On the other hand, when the discharge louver 114 is disposed in a direction perpendicular to the front panel 110 (a second position), the discharge hole 113 may be fully opened.

**[0057]** As the discharge louver 114 is changed in rotating angle from the first position to the second position, the discharge hole 113 may increase in opened degree. The more the discharge hole 113 increases in opened degree, the more air discharged through the discharge hole 113 increases in discharge amount. Also, the more the discharge hole 113 decreases in opened degree, the more the air decreases in discharge amount. Also, a discharge direction of the air may be determined according to the rotating angle of the discharge louver 114.

**[0058]** The wind-visor 200 may be detachably disposed on the front panel 110. The wind-visor 200 may prevent air discharged through the discharge hole 113 from being directly discharged to the user. The wind-visor 200 includes a portion that vertically overlaps with the discharge hole 113 and a portion that does not overlap with the discharge hole 113. Although described below, the overlapping portion may be defined as a blocking portion 260, and the non-overlapping portion may be defined as an extension portion 270.

**[0059]** In detail, a first virtual line 11 extending forward from the first edge 113a of the discharge hole 113 may meet a front portion or front surface of the wind-visor 200. Also, a second virtual line 12 extending forward from the second edge 113b of the discharge hole 113 may meet the front portion or front surface of the wind-visor 200.

**[0060]** That is to say, when the discharge louver 114 is disposed at the first position, the virtual line extending forward from each of both ends of the discharge louver 114 may meet the wind-visor 200.

**[0061]** Here, the first virtual line 11 may be a reference line for distinguishing a coupling part 210 and a guide part 250 of the wind-visor 200 from each other. That is, the coupling part 210 and the guide part 250 may be partitioned by the first virtual line 12.

**[0062]** Also, the second virtual line 12 may be a reference line for distinguishing the blocking portion 260 and the extension portion 270 of the guide part from each other. That is, the blocking portion 260 and the extension portion 270 may be partitioned by the second virtual line 12.

**[0063]** The wind-visor 200 includes the coupling part 210 attached to the front panel 110 and the guide part 250 extending from the coupling part 210. The coupling part 210 and the guide part 250 may be integrated with

each other. Also, the coupling part 210 may be selectively coupled to the front panel 110, and the guide part 250 may extend from the coupling part 210 to guide the air discharged from the discharge hole 113 in a direction away from the suction hole 111.

**[0064]** In detail, the coupling part 210 may be attached between the discharge hole 113 and the suction hole 111. The coupling part 210 may have one surface that is defined by extending forward from the first edge 113a of the discharge hole 113. That is, the one surface of the coupling part 210 and the first edge 113a may form a flat surface.

**[0065]** In Fig. 5, both sides of the coupling part 210 may be rounded toward both sides of the discharge hole 113 when compared to a central portion of the coupling part 210. That is, the coupling part 210 may be gradually bent outward from the central portion thereof toward both sides of the discharge hole 113 to effectively discharge air toward both sides of the discharge hole 113.

**[0066]** In Fig. 4, the coupling part 210 may have a shape that gradually decreases in cross-section downward from an upper portion thereof. That is to say, the portion (a first portion) of the coupling part 210 coupled to the front panel 110 may have a cross-section greater than that of a portion (a second portion) extending forward from the first portion. That is, the coupling part 210 may have a cross-section that gradually decreases from the front panel 110 toward the guide part 250.

**[0067]** When the central portion 110a of the front panel 110 protrudes forward, the portion of the coupling part 210 coupled to the front panel 110 may have a shape of which a central portion is bent forward to correspond to the shape of the front panel 110.

**[0068]** A first coupling unit 220 to be coupled to the front panel 110 may be disposed on the coupling part 210. The first coupling unit 220 may include a first installation groove 222 that is recessed from one side of the coupling part 210 and a first magnet 224 disposed in the first installation groove 222.

**[0069]** Here, the one side of the coupling part 210 may be understood as a coupling surface to be coupled to the front panel 110.

**[0070]** The first magnet 224 may be disposed in the first installation groove 222.

**[0071]** For another example, the coupling part 210 may be manufactured in a state where the first magnet 224 is built in the coupling part 210. That is, the wind-visor 200 may be injection-molded in a form in which the first magnet 224 is inserted into the coupling part 210.

**[0072]** The front panel 110 may include a second coupling unit 116 that is selectively coupled to the first coupling unit 220. The second coupling unit 116 may include a second magnet 118 that exerts an attractive force with respect to the first magnet 224 and thus is selectively coupled to the first magnet 224 and a second installation groove 117 in which the second magnet 118 is inserted.

**[0073]** The second installation groove 117 may be defined between the discharge hole 113 and the suction

hole 111 with respect to the front panel 110.

**[0074]** Also, the second installation groove 117 may be recessed from one surface of the front panel 110, i.e., "a back surface" of the front panel 110. That is, the second installation groove 117 may be disposed so that the second installation groove 117 goes out of sight. Here, it may be understood that the wind-visor 200 is coupled to a "front surface" of the front panel 110.

**[0075]** The guide part 250 may guide the air discharged through the discharge hole 113 toward the outside of the front panel 110. The guide part 250 may include a blocking portion 260 that vertically overlaps with the discharge hole 113 and an extension portion 270 that extends from the blocking portion 260.

**[0076]** The blocking portion 260 may be understood as a portion of the guide part 250 disposed between the first virtual line 11 and the second virtual line 12.

**[0077]** The blocking portion 260 may block the air discharged directly downward from the discharge hole 113. In detail, the blocking portion 260 may extend from the coupling part 210 toward the outside of the front side of the front panel 110 to prevent the air from being discharged directly downward from the discharge hole 113.

**[0078]** In Fig. 5, both sides of the blocking portion 260 may be bent toward both sides of the discharge hole 113 when compared to a central portion of the blocking portion 260. That is, the blocking portion 260 may be gradually bent outward from the central portion thereof toward both sides of the discharge hole 113 to guide the air blocked by the blocking portion 260 to both sides of the discharge hole 113.

**[0079]** The extension portion 270 may guide the air discharged from the discharge hole 113 in a direction that is far away from the air conditioner 10. The extension portion 270 may be defined as a portion of the guide part 250 that does not vertically overlap with the discharge hole 113.

**[0080]** In summary, the front panel 110 may include a first panel part between the discharge hole 113 and the suction hole 111 and a second panel part disposed on a side opposite to the suction hole with respect to the discharge hole 113. The coupling part 210 may vertically overlap with the first panel part, and the blocking portion may vertically overlap with the discharge hole 113. Also, the extension portion 270 may vertically overlap with the second panel part.

**[0081]** Fig. 5 is a top view of a wind-visor according to an embodiment.

**[0082]** Referring to Fig. 5, a hollow 212 and a support rib 214 crossing the hollow 212 may be defined or disposed in the coupling part 210.

**[0083]** The coupling part 210 may be reduced in weight due to the hollow 212. Also, the hollow 212 may be partitioned into a plurality of spaces by the support rib 214.

**[0084]** At least one space of the plurality of spaces may form the first installation groove 222 in which the first magnet 224 is inserted. In Fig. 5, the first installation groove 222 may be defined in a position that is bilaterally

symmetrical with respect to the central portion of the wind-visor 200.

**[0085]** The coupling part 210 may be maintained in strength by the support rib 214. The support rib 214 may be understood as a structure that forms one wall of the first installation groove 222.

**[0086]** Although embodiments have been described with reference to a number of illustrative embodiments thereof, it should be understood that numerous other modifications and embodiments can be devised by those skilled in the art that will fall within the spirit and scope of the principles of this disclosure. More particularly, various variations and modifications are possible in the component parts and/or arrangements of the subject combination arrangement within the scope of the disclosure, the drawings and the appended claims. In addition to variations and modifications in the component parts and/or arrangements, alternative uses will also be apparent to those skilled in the art.

**[0087]** According to the embodiments, it may prevent the conditioned air, i.e., the hot or warm air from being concentrated into a specific position with the indoor space to uniformly condition air in the indoor space.

**[0088]** Also, since the wind-visor has a simple structure, the manufacturing process of the wind-visor may be simplified to reduce manufacturing costs. Also, the wind-visor may be lightweight to reduce a load applied to the air conditioner and prevent the safety accident due to the falling of the wind-visor from occurring.

**[0089]** Also, since the wind-visor is detachably provided according to the operation mode or indoor conditions, it may be unnecessary to form a separate hole in the outer surface of the air conditioner. Thus, the front panel of the air conditioner may not be deteriorated in durability.

**[0090]** Also, the air backflow phenomenon in which the air discharged from the discharge hole returns to the suction hole of the air conditioner may be prevented to improve energy efficiency in the air conditioner.

## Claims

1. An air conditioner comprising:

- a main body comprising a blower fan (130) generating an air flow and a heat exchanger (120) that is heat-exchanged with air flowing by the blower fan;
- a front panel (110) comprising a suction hole (111) through which the air introduced into the blower fan is suctioned and a discharge hole (113) through which the air heat-exchanged in the heat exchanger is discharged;
- a wind-visor (200) detachably disposed on a side of the discharge hole; and
- a discharge louver (114) disposed in the discharge hole to adjust an opened degree of the discharge hole,

- wherein the wind-visor (200) is coupled to a side of the discharge louver (114) to guide discharge of the air through the discharge hole (113).
2. The air conditioner according to claim 1, wherein the wind-visor (200) is disposed between the discharge hole (113) and the suction hole (111).
  3. The air conditioner according to claim 1, wherein the wind-visor (200) is separably coupled to the front panel (110).
  4. The air conditioner according to claim 1, further comprising:
    - a first magnet (224) disposed on the wind-visor (200); and
    - a second magnet (118) disposed on the front panel (110), the second magnet being selectively coupled to the first magnet.
  5. The air conditioner according to claim 4, further comprising a second installation groove (117) defined in the front panel (110) so that the second magnet (118) is disposed therein, the second installation groove being defined between the discharge hole (113) and the suction hole (111).
  6. The air conditioner according to claim 5, wherein the wind-visor (200) is coupled to a front surface of the front panel (110), and the second installation groove (117) is recessed from a back surface of the front panel (110).
  7. The air conditioner according to claim 1, wherein the wind-visor (200) comprises:
    - a coupling part (210) selectively coupled to a front side of the front panel (110); and
    - a guide part (250) extending from the coupling part to guide the air discharged from the discharge hole (113) in a direction away from the suction hole (111).
  8. The air conditioner according to claim 7, wherein the guide part (250) comprises:
    - a blocking portion (260) overlapping with the discharge hole (113) at a front side of the discharge hole; and
    - an extension portion (270) extending from the blocking portion without overlapping with the discharge hole (113) at the front side of the discharge hole.
  9. The air conditioner according to claim 8, wherein the front panel (110) comprises a first edge and a second edge, which define the discharge hole (113), and
    - a first virtual line (11) extending forward from the first edge and a second virtual line (12) extending forward from the second edge meet a front portion or front surface of the wind-visor (200).
  10. The air conditioner according to claim 9, wherein the second virtual line (12) defines a reference line to distinguish the coupling part (210) and guide part (250) of the wind-visor (200) from each other.
  11. The air conditioner according to claim 7, wherein the coupling part (210) comprises:
    - a first magnet (224) selectively coupled to a second magnet (118) of the front panel (110); and
    - a first installation groove (222) in which the first magnet (224) is disposed.
  12. The air conditioner according to claim 11, wherein the coupling part (210) comprises:
    - a plurality of hollows (212); and
    - at least one support rib (214) for partitioning the plurality of hollows.
  13. The air conditioner according to claim 12, wherein at least one hollow (212) of the plurality of hollows comprises the first installation groove (222).
  14. The air conditioner according to claim 7, wherein the coupling part (210) has a cross-section size that gradually decreases in width from the front panel (110) toward the guide part (250).

## Patentansprüche

### 1. Klimaanlage, die aufweist:

- einen Hauptkörper, der einen Gebläseventilator (130), der einen Luftstrom erzeugt, und einen Wärmetauscher (120) aufweist, der mit Luft wärmegetauscht wird, die durch den Gebläseventilator strömt;
- eine Frontplatte (110), die eine Ansaugöffnung (111), durch die die in den Gebläseventilator eingeleitete Luft angesaugt wird, und eine Ausstoßöffnung (113) aufweist, durch die die im Wärmetauscher wärmegetauschte Luft ausgestoßen wird;
- einen Windschutz (200), der abnehmbar auf einer Seite der Ausstoßöffnung angeordnet ist; und
- eine Ausstoßlamelle (114), die in der Ausstoßöffnung angeordnet ist, um einen Öffnungsgrad der Ausstoßöffnung einzustellen, wobei der Windschutz (200) mit einer Seite der Ausstoßlamelle (114) gekoppelt ist, um den

- Ausstoß der Luft durch die Ausstoßöffnung (113) zu leiten.
2. Klimaanlage nach Anspruch 1, wobei der Windschutz (200) zwischen der Ausstoßöffnung (113) und der Ansaugöffnung (111) angeordnet ist. 5
  3. Klimaanlage nach Anspruch 1, wobei der Windschutz (200) getrennt mit der Frontplatte (110) gekoppelt ist. 10
  4. Klimaanlage nach Anspruch 1, die ferner aufweist:
    - einen ersten Magnet (224), der am Windschutz (200) angeordnet ist; und
    - einen zweiten Magnet (118), der an der Frontplatte (110) angeordnet ist, wobei der zweite Magnet selektiv mit dem ersten Magnet gekoppelt ist. 15
  5. Klimaanlage nach Anspruch 4, die ferner eine zweite Einbaunut (117) aufweist, die in der Frontplatte (110) so ausgebildet ist, dass der zweite Magnet (118) darin angeordnet ist, wobei die zweite Einbaunut zwischen der Ausstoßöffnung (113) und der Ansaugöffnung (111) definiert ist. 20
  6. Klimaanlage nach Anspruch 5, wobei der Windschutz (200) mit einer Vorderseite der Frontplatte (110) gekoppelt ist und die zweite Einbaunut (117) von einer Rückseite der Frontplatte (110) ausgespart ist. 25
  7. Klimaanlage nach Anspruch 1, wobei der Windschutz (200) aufweist:
    - einen Kopplungsteil (210), der selektiv mit einer Vorderseite der Frontplatte (110) gekoppelt ist; und
    - einen Führungsteil (250), der sich vom Kopplungsteil erstreckt, um die aus der Ausstoßöffnung (113) ausgestoßene Luft in eine Richtung weg von der Ansaugöffnung (111) zu leiten. 30
  8. Klimaanlage nach Anspruch 7, wobei der Führungsteil (250) aufweist:
    - eine Sperrabschnitt (260), der sich mit der Ausstoßöffnung (113) an einer Vorderseite der Ausstoßöffnung überlappt; und
    - einen Verlängerungsabschnitt (270), der sich Sperrabschnitt erstreckt, ohne sich mit der Ausstoßöffnung (113) an der Vorderseite der Ausstoßöffnung zu überlappen. 35
  9. Klimaanlage nach Anspruch 8, wobei die Frontplatte (110) eine erste Kante und eine zweite Kante aufweist, die die Ausstoßöffnung (113) definieren, und
    - eine erste virtuelle Linie (11), die sich von der ersten Kante nach vorn erstreckt, und eine zweite virtuelle Linie (12), die sich von der zweiten Kante nach vorn erstreckt, einen vorderen Abschnitt oder eine Vorderseite des Windschutzes (200) treffen. 40
  10. Klimaanlage nach Anspruch 9, wobei die zweite virtuelle Linie (12) eine Bezugslinie definiert, um den Kopplungsteil (210) und den Führungsteil (250) des Windschutzes (200) voneinander zu unterscheiden. 45
  11. Klimaanlage nach Anspruch 7, wobei der Kopplungsteil (210) aufweist:
    - einen ersten Magnet (224), der selektiv mit einem zweiten Magnet (118) der Frontplatte (110) gekoppelt ist; und
    - eine erste Einbaunut (222), in die der erste Magnet (224) angeordnet ist. 50
  12. Klimaanlage nach Anspruch 11, wobei der Kopplungsteil (210) aufweist:
    - mehrere Hohlräume (212); und
    - mindestens eine Halterippe (214) zum Unterteilen der mehreren Hohlräume. 55
  13. Klimaanlage nach Anspruch 12, wobei mindestens ein Hohlraum (212) der mehreren Hohlräume die erste Einbaunut (222) aufweist.
  14. Klimaanlage nach Anspruch 7, wobei der Kopplungsteil (210) eine Querschnittsabmessung aufweist, deren Breite von der Frontplatte (110) zum Führungsteil (250) allmählich abnimmt.

## Revendications

### 1. Climatiseur, comprenant :

un corps principal comportant un ventilateur de soufflage (130) générant un flux d'air et un échangeur de chaleur (120) soumettant à échange de chaleur l'air soufflé par le ventilateur de soufflage ;  
 un panneau avant (110) comprenant un orifice d'aspiration (111) par lequel l'air entrant dans le ventilateur de soufflage est aspiré et un orifice de refoulement (113) par lequel l'air soumis à échange de chaleur dans l'échangeur de chaleur est refoulé ;  
 un écran coupe-vent (200) monté de manière amovible sur un côté de l'orifice de refoulement ;  
 et  
 un volet de refoulement (114) monté dans l'orifice de refoulement pour régler un degré d'ouverture de l'orifice de refoulement,

- où l'écran coupe-vent (200) est raccordé à un côté du volet de refoulement (114) pour guider l'évacuation de l'air par l'orifice de refoulement (113).
2. Climatiseur selon la revendication 1, où l'écran coupe-vent (200) est disposé entre l'orifice de refoulement (113) et l'orifice d'aspiration (111).
3. Climatiseur selon la revendication 1, où l'écran coupe-vent (200) est raccordé de manière amovible au panneau avant (110).
4. Climatiseur selon la revendication 1, comprenant en outre :
- un premier aimant (224) monté sur l'écran coupe-vent (200) ; et  
un deuxième aimant (118) monté sur le panneau avant (110),  
le deuxième aimant étant couplé sélectivement au premier aimant.
5. Climatiseur selon la revendication 4, comprenant en outre une deuxième rainure de montage (117) définie dans le panneau avant (110) de manière à y inclure le deuxième aimant (118), ladite deuxième rainure de montage étant définie entre l'orifice de refoulement (113) et l'orifice d'aspiration (111).
6. Climatiseur selon la revendication 5, où l'écran coupe-vent (200) est raccordé à une surface avant du panneau avant (110), et la deuxième rainure de montage (117) est ménagée dans une surface arrière du panneau avant (110).
7. Climatiseur selon la revendication 1, où l'écran coupe-vent (200) comprend :
- une partie de liaison (210) raccordée sélectivement à la face avant du panneau avant (110); et  
une partie de guidage (250) s'étendant depuis la partie de liaison pour guider l'air évacué par l'orifice de refoulement (113) dans une direction opposée à l'orifice d'aspiration (111).
8. Climatiseur selon la revendication 7, où la partie de guidage (250) comprend :
- une partie de blocage (260) en chevauchement avec l'orifice de refoulement (113) sur le côté avant de l'orifice de refoulement ; et  
une partie d'extension (270) s'étendant depuis la partie de blocage sans chevaucher l'orifice de refoulement (113) sur le côté avant de l'orifice de refoulement.
9. Climatiseur selon la revendication 8, où le panneau
- avant (110) comprend un premier bord et un deuxième bord définissant l'orifice de refoulement (113), et où une première ligne virtuelle (11) s'étendant vers l'avant depuis le premier bord et une deuxième ligne virtuelle (12) s'étendant vers l'avant depuis le deuxième bord sont incidentes à une partie avant ou à une surface avant de l'écran coupe-vent (200).
10. Climatiseur selon la revendication 9, où la deuxième ligne virtuelle (12) définit une ligne de référence pour distinguer l'une de l'autre la partie de liaison (210) et la partie de guidage (250) de l'écran coupe-vent (200).
11. Climatiseur selon la revendication 7, où la partie de liaison (210) comprend :
- un premier aimant (224) couplé sélectivement à un deuxième aimant (118) du panneau avant (110) ; et  
une première rainure de montage (222) où est monté le premier aimant (224).
12. Climatiseur selon la revendication 11, où la partie de liaison (210) comprend :
- une pluralité de cavités (212); et  
au moins une entretoise de support (214) pour la séparation de la pluralité de cavités.
13. Climatiseur selon la revendication 12, où au moins une cavité (212) de la pluralité de cavités comprend la première rainure de montage (222).
14. Climatiseur selon la revendication 7, où la partie de liaison (210) présente une grandeur de section transversale diminuant progressivement en largeur du panneau avant (110) à la partie de guidage (250).

Fig. 1

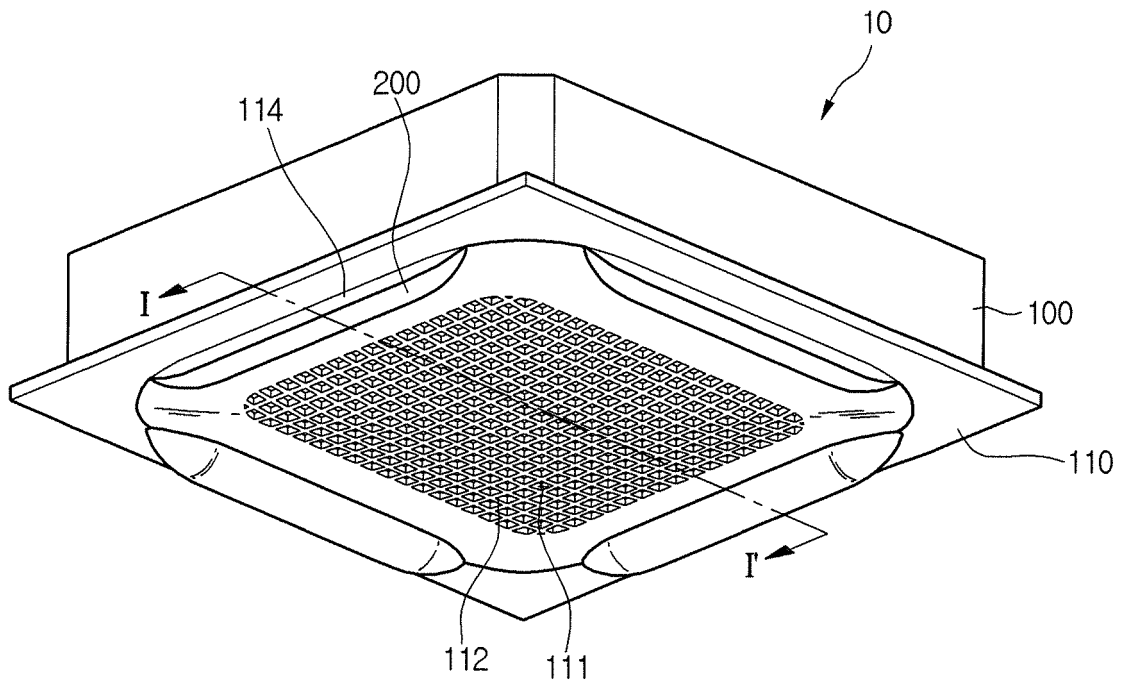

Fig. 2

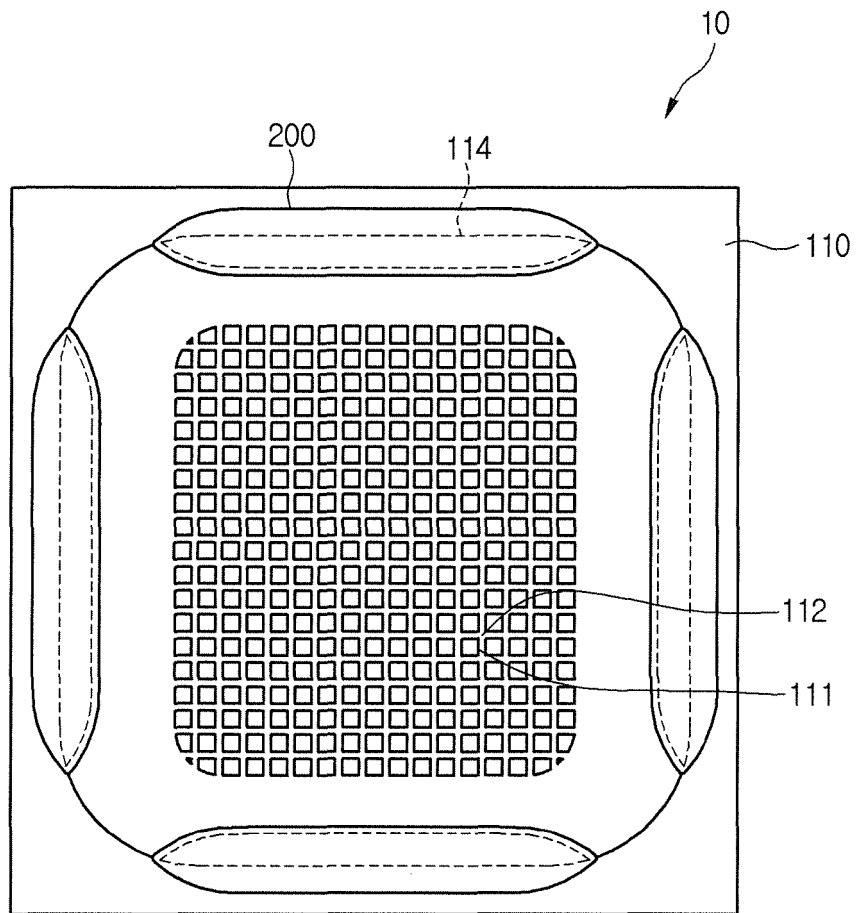

Fig. 3

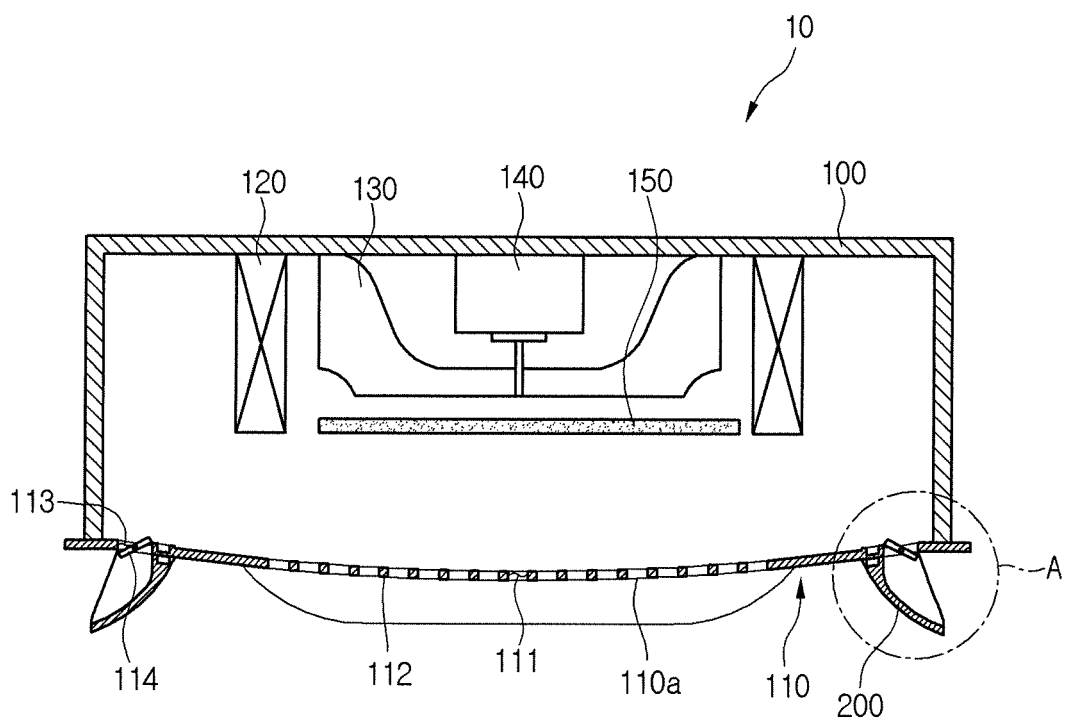

Fig. 4

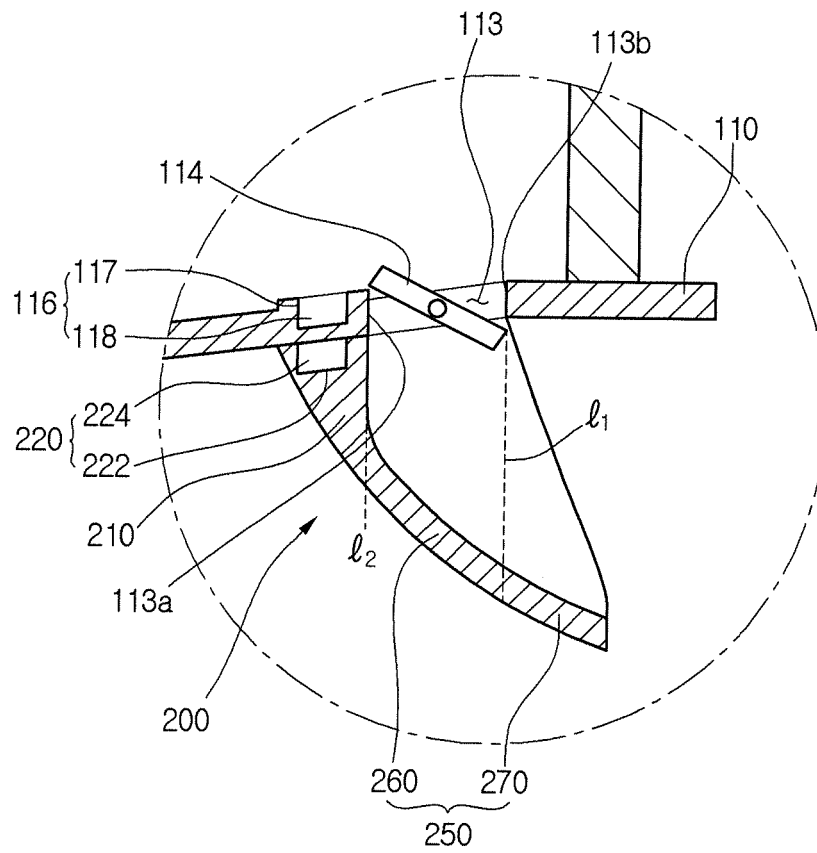
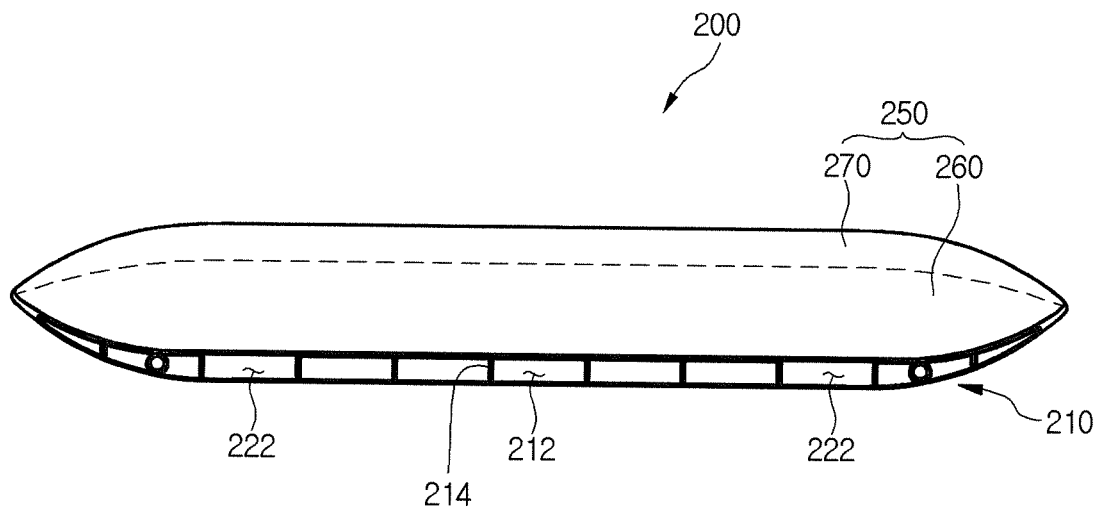

Fig. 5



**REFERENCES CITED IN THE DESCRIPTION**

*This list of references cited by the applicant is for the reader's convenience only. It does not form part of the European patent document. Even though great care has been taken in compiling the references, errors or omissions cannot be excluded and the EPO disclaims all liability in this regard.*

**Patent documents cited in the description**

- KR 102012011822 [0007]
- JP 2010084996 A [0012]