

(19)  
(12)

(KR)  
(B1)

(51) 。 Int. Cl.7  
B60J 3/00

(45)  
(11)  
(24)

2003 06 18  
10-0387635  
2003 06 02

(21) 10-2000-0065024  
(22) 2000 11 02

(65)  
(43)

2002-0034618  
2002 05 09

(73) 231

(72) 3 APT1310 1401

(74)  
:

(54)

2

1  
2  
3

10 : 11 :  
12 : 13 :  
14 : 15 :  
16 : 17 :

(100) (12) (10) (11) (12) , 1

(先)

가

(12) (10) (100) (12) 3 (100) (14) (11) (15) (13) (15)  
 (10) (13) (100) (100) (16) (17)  
 (13) (16) 120° 3

2

(100) (10) (10) (100) (100) (13) (10)

(100) (10) (100) (10) (13)

(13) 3 (100) (10) 3 (14)  
 (15) (15) (16) (15) (12)

(13) (13) (15) (17)가 (100)

(13) (16) 3 120° (10) (12) 가 (13)  
 (13) (13) (16) (100) (100) (13)

(10) (13) 가 (17) (13) (13)

(57)

1.

(100) (14) (16) (11) (15) (13) (15) (12) (10) (10) (12) 3

2.

3.

1 (17) (13) (100)

4.

1 (13) (16) 120° 3

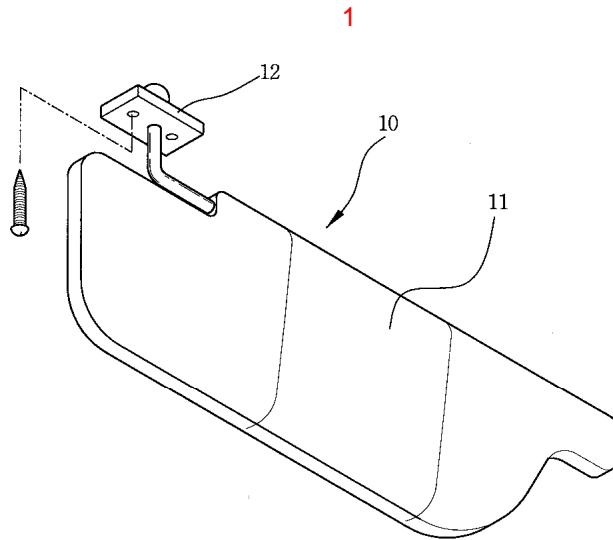

2

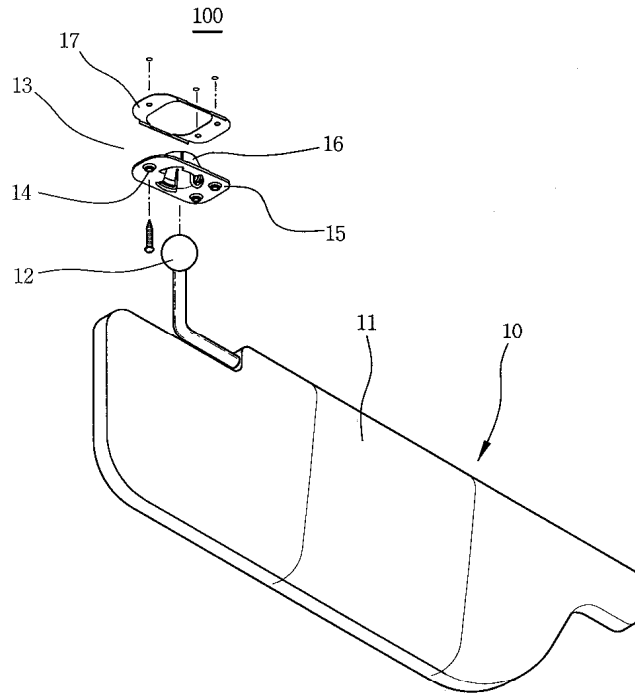

3

