



- (51) International Patent Classification:
E21B 47/00 (2012.01)
- (21) International Application Number:
PCT/US2013/076269
- (22) International Filing Date:
18 December 2013 (18.12.2013)
- (25) Filing Language:
English
- (26) Publication Language:
English
- (30) Priority Data:
61/739,414 19 December 2012 (19.12.2012) US
- (71) Applicant (for all designated States except US): **EXXON-MOBIL UPSTREAM RESEARCH COMPANY** [US/US]; CORP-URC-SW359, P.O. Box 2189, Houston, TX 77252-2189 (US).
- (72) Inventors; and
- (71) Applicants (for US only): **DISKO, Mark, M.** [US/US]; 612 Woodglen Rd., Glen Gardner, NJ 08826 (US). **MOR-**

ROW, Timothy, I. [US/US]; 9806 Moonscape View, Humble, TX 77396 (US). **DEFFENBAUGH, Max** [US/US]; 401 County Road 513, Califon, NJ 07830 (US). **WALKER, Katie, M.** [US/US]; 172 Preston Rd. Apt C5, Milford, NJ 08848 (US). **CLAWSON, Scott, W.** [US/US]; 484 County Road 513, Califon, NJ 07830 (US). **WOLF, Henry, Alan** [US/US]; 145 Lake Rd., Morristown, NJ 07960 (US).

(74) Agents: **JAMES, Rick F.** et al.; ExxonMobil Upstream Research Company, CORP-URC-SW359, P.O. Box 2189, Houston, TX 77252-2189 (US).

(81) Designated States (unless otherwise indicated, for every kind of national protection available): AE, AG, AL, AM, AO, AT, AU, AZ, BA, BB, BG, BH, BN, BR, BW, BY, BZ, CA, CH, CL, CN, CO, CR, CU, CZ, DE, DK, DM, DO, DZ, EC, EE, EG, ES, FI, GB, GD, GE, GH, GM, GT, HN, HR, HU, ID, IL, IN, IR, IS, JP, KE, KG, KN, KP, KR, KZ, LA, LC, LK, LR, LS, LT, LU, LY, MA, MD, ME, MG, MK, MN, MW, MX, MY, MZ, NA, NG, NI, NO, NZ, OM, PA, PE, PG, PH, PL, PT, QA, RO, RS, RU, RW, SA,

[Continued on next page]

(54) Title: TELEMETRY FOR WIRELESS ELECTRO-ACOUSTICAL TRANSMISSION OF DATA ALONG A WELLBORE

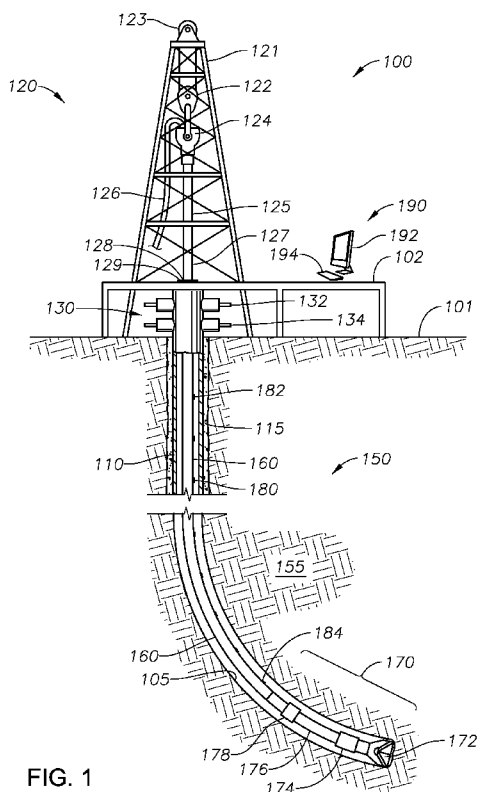

FIG. 1

(57) Abstract: A system for downhole telemetry is provided herein. The system employs a series of communications nodes spaced along a tubular body either above or below ground, such as in a wellbore. The nodes allow for wireless communication between one or more sensors residing at the level of a subsurface formation or along a pipeline, and a receiver at the surface. The communications nodes employ electro-acoustic transducers that provide for node-to-node communication along the tubular body at high data transmission rates. A method of transmitting data in a wellbore is also provided herein. The method uses a plurality of data transmission nodes situated along a tubular body and a specially configured network to accomplish a wireless transmission of data along the wellbore using acoustic energy.



SC, SD, SE, SG, SK, SL, SM, ST, SV, SY, TH, TJ, TM, TN, TR, TT, TZ, UA, UG, US, UZ, VC, VN, ZA, ZM, ZW.

SM, TR), OAPI (BF, BJ, CF, CG, CI, CM, GA, GN, GQ, GW, KM, ML, MR, NE, SN, TD, TG).

(84) Designated States (*unless otherwise indicated, for every kind of regional protection available*): ARIPO (BW, GH, GM, KE, LR, LS, MW, MZ, NA, RW, SD, SL, SZ, TZ, UG, ZM, ZW), Eurasian (AM, AZ, BY, KG, KZ, RU, TJ, TM), European (AL, AT, BE, BG, CH, CY, CZ, DE, DK, EE, ES, FI, FR, GB, GR, HR, HU, IE, IS, IT, LT, LU, LV, MC, MK, MT, NL, NO, PL, PT, RO, RS, SE, SI, SK,

Published:

- with international search report (*Art. 21(3)*)
- before the expiration of the time limit for amending the claims and to be republished in the event of receipt of amendments (*Rule 48.2(h)*)

**TELEMETRY FOR WIRELESS ELECTRO-ACOUSTICAL
TRANSMISSION OF DATA ALONG A WELLBORE**

CROSS-REFERENCE TO RELATED APPLICATIONS

[0001] This application claims the benefit of U.S. Serial No. 61/739,414, filed December 19, 2012, the entire contents of which are hereby incorporated by reference herein. This application is further related to co-pending U.S. Serial Nos. 61/739,679, 61/739,677, 61/739,678, and 61/739,681, each filed on December 19, 2012, the entire contents of each of which are also hereby incorporated by reference herein.

BACKGROUND OF THE INVENTION

[0002] This section is intended to introduce various aspects of the art, which may be associated with exemplary embodiments of the present disclosure. This discussion is believed to assist in providing a framework to facilitate a better understanding of particular aspects of the present disclosure. Accordingly, it should be understood that this section should be read in this light, and not necessarily as admissions of prior art.

FIELD OF THE INVENTION

[0003] The present invention relates to the field of data transmission along a tubular body, such as a steel pipe. More specifically, the invention relates to the transmission of data along a pipe within a wellbore or along a pipeline at the surface or in a body of water. The present invention further relates to a wireless transmission system for transmitting data up a drill string during a drilling operation or along the casing during drilling or production operations. The present invention further relates to the use of acoustic telemetry signals along a wellbore to optimize communication protocol for speed, for power conservation and for low error rates.

GENERAL DISCUSSION OF TECHNOLOGY

[0004] It is desirable to transmit data along a pipeline without the need for wires or radio frequency (electromagnetic) communications devices. Examples abound where the installation of wires is either technically difficult or economically impractical. The use of radio transmission may also be impractical or unavailable in cases where radio-activated blasting is occurring, or where the attenuation of radio waves near the tubular body is significant.

[0005] Likewise, it is desirable to collect and transmit data along a tubular body in a wellbore, such as during a drilling process. In the drilling of oil and gas wells, a wellbore is formed using a drill bit that is urged downwardly at a lower end of a drill string. The drill bit

is rotated while force is applied through the drill string and against the rock face of the formation being drilled. During this process, the operator may seek to acquire real time data related to temperature, pressure, rate of rock penetration, inclination, azimuth, fluid composition, and local geology. In order to obtain such information, special downhole assemblies have been developed. These assemblies are generally referred to as Logging While Drilling (LWD) or Measurement While Drilling (MWD) assemblies, or generically as bottom hole assemblies.

[0006] LWD and MWD assemblies are typically placed proximate the drill bit at the bottom of the drill string. Bottom hole assemblies having LWD or MWD capabilities are able to store or transmit information about subsurface conditions for review by drilling or production operators at the surface. LWD and MWD techniques generally seek to reduce the need for tripping the drill string and running wireline logs to obtain downhole data.

[0007] A variety of technologies have been proposed or developed for downhole communications using LWD or MWD. In one form, MWD and LWD information is simply stored in a microprocessor having memory. The microprocessor is retrieved and the information is downloaded later when the drill string is pulled, such as when a drill bit is changed out or a new bottom hole assembly is installed.

[0008] Several real time data telemetry systems have also been offered. One involves the use of a physical cable such as an electrical conductor or a fiber optic cable that is secured to the tubular body. The cable may be secured to either the inner or the outer diameter of the pipe. The cable provides a hard wire connection that allows for real-time transmission of data and the immediate evaluation of subsurface conditions. Further, these cables allow for high data transmission rates and the delivery of electrical power directly to downhole sensors.

[0009] It can be readily perceived that the placement of a physical cable along a string of drill pipe during drilling is problematic. In this respect, the cable will become quickly tangled and will break if secured along a rotating drill string. This problem is lessened when a downhole mud motor is used that allows for a generally non-rotating drill pipe. However, even in this instance the harsh downhole environment and the considerable force of the pipe as it scrapes across the surrounding borehole can impair the cable.

[0010] It has been proposed to place a physical cable along the outside of a casing string during well completion. However, this can be difficult as the placement of wires along a pipe string requires that thousands of feet of cable be carefully unspooled and fed during pipe connection and run-in. Further, the use of hard wires in a well completion requires the installation of a specially-designed well head that includes through-openings for the wires. In

addition, if the wire runs outside of a casing string, this creates a potential weak spot in the cement sheath that may contribute to a loss of pressure isolation between subsurface intervals. It is generally not feasible to pass wires through a casing mandrel for subsea applications. In sum, passing cable in the annulus adds significant cost, both for equipment and for rig time, to well completions.

[0011] Mud pulse telemetry, or mud pressure pulse transmission, is commonly used during drilling to obtain data from sensors at or near the drill bit. Mud pulse telemetry employs variations in pressure in the drilling mud to transmit signals from the bottom hole assembly to the surface. The variations in pressure may be sensed and analyzed by a computer at the surface.

[0012] A downside to mud pulse telemetry is that it transmits data to the surface at relatively slow rates, typically at rates of less than 20 bits per second (bps). This rate decreases as the length of the wellbore increases, even down to 10 or fewer bps. Slow data transmission rates can be costly to the drilling process. For example, the time it takes to downlink instructions and uplink survey data (such as azimuth and inclination), during which the drill string is normally held stationary, can be two to seven minutes. Since many survey stations are typically required, this downlink/uplink time can be very expensive, especially on deepwater rigs where daily operational rates can exceed \$2 million. Similarly, the time it takes to downlink instructions and uplink data associated with many other tasks such as setting parameters in a rotary steerable directional drilling tool or obtaining a pressure reading from a pore-pressure-while-drilling tool can be very costly.

[0013] The use of acoustic telemetry has also been suggested. Acoustic telemetry employs an acoustic signal generated at or near the bottom hole assembly or bottom of a pipe string. The signal is transmitted through the wellbore pipe, meaning that the pipe becomes the carrier medium for sound waves. Transmitted sound waves are detected by a receiver and converted to electrical signals for analysis.

[0014] U.S. Patent No. 5,924,499 entitled "Acoustic Data Link and Formation Property Sensor for Downhole MWD System" teaches the use of acoustic signals for "short hopping" a component along a drill string. Signals are transmitted from the drill bit or from a near-bit sub and across the mud motors. This may be done by sending separate acoustic signals simultaneously -- one that is sent through the drill string, a second that is sent through the drilling mud, and optionally, a third that is sent through the formation. These signals are then processed to extract readable signals.

[0015] U.S. Patent No. 6,912,177, entitled “Transmission of Data in Boreholes,” addresses the use of an acoustic transmitter that is part of a downhole tool. Here, the transmitter is provided adjacent a downhole obstruction such as a shut-in valve along a drill stem so that an electrical signal may be sent across the drill stem. U.S. Patent No. 6,899,178, entitled “Method and System for Wireless Communications for Downhole Applications,” describes the use of a “wireless tool transceiver” that utilizes acoustic signaling. Here, an acoustic transceiver is in a dedicated tubular body that is integral with a gauge and/or sensor. This is described as part of a well completion.

[0016] Faster data transmission rates with some level of clarity have been accomplished using electromagnetic (EM) telemetry. EM telemetry employs electromagnetic waves, or alternating current magnetic fields, to “jump” across pipe joints. In practice, a specially-milled drill pipe is provided that has a conductor wire machined along an inner diameter. The conductor wire transmits signals to an induction coil at the end of the pipe. The induction coil, in turn, then transmits an EM signal to another induction coil, which sends that signal through the conductor wire in the next pipe. Thus, each threaded connection provides a pair of specially milled pipe ends for EM communication.

[0017] National Oilwell Varco[®] of Houston, Texas offers a drill pipe network, referred to as IntelliServ[®], that uses EM telemetry. The IntelliServ[®] system employs drill pipe having integral wires that can transmit LWD/MWD data to the surface at speeds of up to 1 Mbps. This creates a communications system from the drill string itself. The IntelliServ[®] communications system uses an induction coil built into both the threaded box and pin ends of the drill pipe joints so that data may be transmitted across each connection. Examples of IntelliServ[®] patents are U.S. Patent No. 7,277,026 entitled “Downhole Component With Multiple Transmission Elements,” and U.S. Patent No. 6,670,880 entitled “Downhole Data Transmission System.”

[0018] It is observed that the induction coils in an EM telemetry system must be precisely located in the box and pin ends of the joints of the drill string to ensure reliable data transfer. For a long (e.g., 20,000 foot) well, there can be more than 600 tool joints. This represents over 600 pipe sections to be threadedly connected. Further, each threaded connection is preferably tested at the drilling platform to ensure proper functioning.

[0019] National Oilwell Varco[®] promotes its IntelliServ[®] system as providing the oil and gas industry’s “only high-speed, high-volume, high-definition, bi-directional broadband data transmission system that enables downhole conditions to be measured, evaluated, monitored and actuated in real time.” However, the IntelliServ[®] system generally requires the use of

booster assemblies along the drill string. These can be three to six foot sub joints having a diameter greater than the drill pipe placed in the drill string. The booster assemblies, referred to sometimes as “signal repeaters,” are located along the drill pipe about every 1,500 feet. The need for repeaters coupled with the need for specially-milled pipe can make the IntelliServ[®] system a very expensive option.

[0020] Recently, the use of radiofrequency signals has been suggested. This is offered in U.S. Pat. No. 8,242,928 entitled “Reliable Downhole Data Transmission System.” This patent suggests the use of electrodes placed in the pin and box ends of pipe joints. The electrodes are tuned to receive RF signals that are transmitted along the pipe joints having a conductor material placed there along, with the conductor material being protected by a special insulative coating.

[0021] While high data transmission rates can be accomplished using RF signals in a downhole environment, the transmission range is typically limited to a few meters. This, in turn, requires the use of numerous repeaters.

[0022] Accordingly, a need exists for a high speed wireless transmission system in a wellbore that does not require the machining of induction coils with precise grooves placed into pipe ends or the need for electrodes in the pipe ends or couplings. Further, a need exists for such a wireless transmission system that does not require the precise alignment of induction coils or the placement of RF electrodes between pipe joints.

SUMMARY OF THE INVENTION

[0023] A system for downhole telemetry is provided herein. The system employs a series of autonomous communications nodes spaced along a wellbore. The nodes allow for wireless communication between one or more sensors residing at the level of a subsurface formation, and a receiver at the surface.

[0024] The system first includes a tubular body disposed in the wellbore. Where the wellbore is being formed, the tubular body is a drill string, with the wellbore progressively penetrating into a subsurface formation. The subsurface formation preferably represents a rock matrix having hydrocarbon fluids available for production in commercially acceptable volumes. Thus, the wellbore is to be completed as a production well, or “producer.” Alternatively, the wellbore is to be completed as an injection well or a formation monitoring well.

[0025] In another aspect, the wellbore has already been completed. The tubular body is then a casing string or, alternatively, a production string such as tubing.

[0026] The system also includes at least one sensor. As noted, the sensor is disposed along the wellbore at a depth of the subsurface formation. The sensor may be, for example, a temperature sensor, a pressure sensor, a microphone, a geophone, a vibration sensor, a resistivity sensor, a fluid flow measurement device, a chemical composition or pH sensor, a formation density sensor, a fluid identification sensor, or a strain gauge. Where the wellbore is being drilled, the sensor may alternatively be a set of position sensors indicating, inclination, azimuth, and orientation.

[0027] The system further has one or more a sensor communications nodes. The sensor communications nodes are placed along the wellbore, such as along a drill string or along a casing string. At least one of the sensor communications nodes is connected to the tubular body at the depth of the subsurface formation. The sensor communications node along the subsurface formation is in electrical communication with a sensor. Preferably, the sensor resides within a housing of the sensor communications node.

[0028] The sensor communications node is configured to receive signals from the at least one sensor. The signals represent a subsurface condition such as temperature, pressure, or logging information. The sensor communications node preferably includes a sealed housing for holding the electronics.

[0029] The system also comprises a topside communications node. The topside communications node is placed proximate the surface, such as on the wellhead or other near-surface equipment in acoustic communication with downhole tubular bodies. In one aspect, the topside communications node is connected to the wellhead. The surface may be an earth surface. Alternatively, in a subsea context, the surface may be an offshore drilling or production platform.

[0030] The system further includes a plurality of intermediate communications nodes. The intermediate communications nodes are attached to the tubular body in spaced-apart relation. In one aspect, the intermediate communications nodes are spaced at about 10 to about 100 foot (~3 meter to ~30 meter) intervals. The intermediate communications nodes are configured to relay messages between from the sensor communications node and the topside communications node. In one embodiment, the sensor communications node is fully housed with the intermediate communications node.

[0031] Each of the intermediate communications nodes has an independent power source. The power source may be, for example, batteries or a fuel cell. In addition, each of the intermediate communications nodes has an electro-acoustic transducer and associated transceiver that is used to establish telemetry. The transceiver is designed to receive and

transmit acoustic waves at a frequency range enabling (i) node-to-node acoustic transmission and (ii) a modulation scheme permitting the transfer of information.

[0032] The acoustic waves represent the readings taken and data generated by the sensor. In this way, data about subsurface conditions are transmitted wirelessly from node-to-node up to the surface. The acoustic waves represent asynchronous packets of information comprising a plurality of tones. Each tone may have a non-prescribed amplitude, a non-prescribed reverberation time, or both. In one aspect, the communications nodes transmit data as mechanical waves at a rate exceeding about 50 bps. In a preferred embodiment, multiple frequency shift keying (MFSK) is the modulation scheme enabling the transmission of information.

[0033] A method of transmitting data in a wellbore is also provided herein. The method uses a plurality of data transmission nodes situated along a tubular body to accomplish a wireless transmission of data along the wellbore. The wellbore penetrates into a subsurface formation, allowing for the communication of a wellbore condition at the level of the subsurface formation up to the surface.

[0034] The method first includes running a tubular body into the wellbore. The tubular body is formed by connecting a series of pipe joints end-to-end.

[0035] The method also includes placing at least one sensor along the wellbore at a depth of the subsurface formation. The sensor may be a pressure sensor, a temperature sensor, a set of position sensors, a vibration sensor, a formation density sensor, a strain gauge, a sonic velocity sensor, a resistivity sensor, or other chemical or physical sensor.

[0036] The method further includes attaching a sensor communications node to the tubular body. The sensor communications node is then placed at the depth of the subsurface formation. The sensor communications node is in electrical (or, optionally, optical) communication with the at least one sensor. This communication may be by means of a short wired connection. In one aspect, the sensor resides in the housing of a sensor communications node.

[0037] The sensor communications node is configured to receive signals from the at least one sensor. The signals represent a subsurface condition as detected by the sensor. In one embodiment, the sensor is the same electro-acoustic transducer that enables the telemetry communication. In this way, amplitude and amplitude attenuation values may be analyzed.

[0038] The method also provides for attaching a topside communications node to the tubular body or other structure, such as the well head or the blow out preventer (BOP), that is

connected to the tubular body. The topside communications node is attached to the tubular body proximate the surface.

[0039] The method further comprises attaching a plurality of intermediate communications nodes to the tubular body. The intermediate communications nodes reside in spaced-apart relation along the tubular body between the sensor communications node and the topside communications node. The intermediate communications nodes are configured to relay sensor data via acoustic waves from the sensor communications node to the topside node. The intermediate communications nodes are configured as described above to send asynchronous packets of information. Preferably, a sliding alphabet algorithm is employed for signal processing as a method of reducing adverse impact of reverberation during transmission and reception of messages. In one aspect, the algorithm eliminates the occurrence of two of the same tones sent consecutively (given a set of defined tones associated with defined frequencies) during a MFSK communication.

[0040] In a preferred embodiment, the attaching steps comprise clamping the various communications nodes, that is, at least the sensor communications nodes and the intermediate communications nodes, to the tubular body. These communications nodes are welded or otherwise pre-attached to one or more clamps, which are then secured around the tubular body during run-in.

[0041] In one aspect, the method further includes receiving a signal from the topside communications node at a receiver. The receiver is located at or just above the surface. The receiver preferably receives electrical or optical signals from the topside communications node. In one embodiment, the electrical or optical signals are conveyed in a conduit suitable for operation in an electrically classified area, that is, via a so-called "Class I, Division 1" conduit (as defined by NFPA 497 and API 500). Alternatively, data can be transferred from the topside communications node to a receiver via an electromagnetic (RF) wireless connection. The electrical signals may then be processed and analyzed at the surface.

[0042] As acoustic telemetry signals are sent between the transceivers downhole and a processor at the surface, the acoustic signals may change due to one or more subsurface condition changes. Such changes may include changes in the flexural wave velocity of the pipe, depending on the speed of sound (e.g. in steel, versus mud, versus air), and one or more mechanisms that will attenuate the acoustic telemetry signal as the propagation distance increases. Detection of these changes can be helpful to the operation of the electro-acoustic network as such changes can affect the delay time between individual acoustic "tones" in the packets as well as the optimal frequency band and reverberation times for transmission.

[0043] The operating protocol for the acoustic telemetry network can be adjusted after the network has been deployed. In order to implement changes to network communications, a “bi-lingual” command may be sent. This command enables pairs of nodes to temporarily respond and transmit with both the original operating protocol and the adjusted protocol.

[0044] The changing nature of electro-acoustic waves sent and received by pairs of communication nodes can be used to infer depth-dependent properties. These may include defects in metallic tubing, defects in the coupling between lengths of tubing, and changes in fluid, solid or mixed media along a tubular joint (e.g., water, oil, gas, flowing particles).

BRIEF DESCRIPTION OF THE DRAWINGS

[0045] So that the present inventions can be better understood, certain drawings, charts, graphs and/or flow charts are appended hereto. It is to be noted, however, that the drawings illustrate only selected embodiments of the inventions and are therefore not to be considered limiting of scope, for the inventions may admit to other equally effective embodiments and applications.

[0046] Figure 1 is a side, cross-sectional view of an illustrative wellbore. The wellbore is being formed using a derrick, a drill string and a bottom hole assembly. A series of communications nodes is placed along the drill string as part of a telemetry system.

[0047] Figure 2 is a cross-sectional view of a wellbore having been completed. The illustrative wellbore has been completed as a cased hole completion. A series of communications nodes is placed along a tubing string as part of a telemetry system.

[0048] Figure 3 is a perspective view of an illustrative pipe joint. A communications node (such as a sensor communications node or an intermediate communications node) of the present invention, in one embodiment, is shown exploded away from the pipe joint.

[0049] Figure 4A is a perspective view of a communications node as may be used in the wireless data transmission system of the present invention, in an alternate embodiment.

[0050] Figure 4B is a cross-sectional view of the communications node of Figure 4A. The view is taken along the longitudinal axis of the node. Here, a sensor is provided within the communications node.

[0051] Figure 4C is another cross-sectional view of the communications node of Figure 4A. The view is again taken along the longitudinal axis of the node. Here, a sensor resides along the wellbore external to the communications node.

[0052] Figures 5A and 5B are perspective views of a shoe as may be used on opposing ends of the communications node of Figure 4A, in one embodiment. In Figure 5A, the leading edge, or front, of the shoe is seen. In Figure 5B, the back of the shoe is seen.

[0053] Figure 6 is a perspective view of a communications node system of the present invention, in one embodiment. The communications node system utilizes a pair of clamps for connecting a communications node onto a tubular body.

[0054] Figure 7 is a flowchart demonstrating steps of a method for transmitting data in a wellbore in accordance with the present inventions, in one embodiment.

[0055] Figure 8 provides an example of an asynchronous network message packet as may be used for the acoustic signals in the present invention, in one embodiment.

[0056] Figure 9 is an example of a transition of a communications node from a sleep state to a wake state using a series of wait stubs and a wakeup packet.

[0057] Figure 10 shows an example of a sliding alphabet algorithm as may be used for processing acoustic signals in the present invention, in one embodiment. The algorithm is designed to eliminate the occurrence of two of the same tones sent consecutively (given a set of defined tones associated with defined frequencies) during a MFSK communication.

DETAILED DESCRIPTION OF CERTAIN EMBODIMENTS

Definitions

[0058] As used herein, the term “hydrocarbon” refers to an organic compound that includes primarily, if not exclusively, the elements hydrogen and carbon. Examples of hydrocarbons include any form of natural gas, oil, coal, and bitumen that can be used as a fuel or upgraded into a fuel.

[0059] As used herein, the term “hydrocarbon fluids” refers to a hydrocarbon or mixtures of hydrocarbons that are gases or liquids. For example, hydrocarbon fluids may include a hydrocarbon or mixtures of hydrocarbons that are gases or liquids at formation conditions, at processing conditions, or at ambient conditions (20° C and 1 atm pressure). Hydrocarbon fluids may include, for example, oil, natural gas, gas condensates, coal bed methane, shale oil, shale gas, and other hydrocarbons that are in a gaseous or liquid state.

[0060] As used herein, the term “subsurface” refers to regions below the earth's surface.

[0061] As used herein, the term “sensor” includes any electrical sensing device or gauge. The sensor may be capable of monitoring or detecting pressure, temperature, fluid flow, vibration, resistivity, or other formation data.

[0062] As used herein, the term “formation” refers to any definable subsurface region. The formation may contain one or more hydrocarbon-containing layers, one or more non-hydrocarbon containing layers, an overburden, and/or an underburden of any geologic formation.

[0063] The terms “zone” or “zone of interest” refer to a portion of a formation containing hydrocarbons. The term “hydrocarbon-bearing formation” may alternatively be used.

[0064] As used herein, the term “wellbore” refers to a hole in the subsurface made by drilling or insertion of a conduit into the subsurface. A wellbore may have a substantially circular cross section, or other cross-sectional shape. As used herein, the term “well,” when referring to an opening in the formation, may be used interchangeably with the term “wellbore.”

[0065] The terms “tubular member” or “tubular body” refer to any pipe, such as a joint of casing, a portion of a liner, a drill string, a production tubing, an injection tubing, a pup joint, a buried pipeline, underwater piping, or above-ground pipeline. The tubular body may also be a downhole tubular device such as a joint of sand screen having a base pipe with pre-drilled holes, a slotted liner, or an inflow control device.

Description of Selected Specific Embodiments

[0066] The invention described herein in connection with certain specific embodiments. However, to the extent that the following detailed description is specific to a particular embodiment or a particular use, such is intended to be illustrative only and is not to be construed as limiting the scope of the inventions.

[0067] **Figure 1** is a side, cross-sectional view of an illustrative well site **100**. The well site **100** includes a derrick **120** at an earth surface **101**, and a wellbore **150** extending from the earth surface **101** into an earth subsurface **155**. The wellbore **150** is being formed using the derrick **120**, a drill string **160** below the derrick **120**, and a bottom hole assembly **170** at a lower end of the drill string **160**.

[0068] Referring first to the derrick **120**, the derrick **120** includes a frame structure **121** that extends up from the earth surface **101** and which supports drilling equipment. The derrick **120** also includes a traveling block **122**, a crown block **123** and a swivel **124**. A so-called kelly **125** is attached to the swivel **124**. The kelly **125** has a longitudinally extending bore (not shown) in fluid communication with a kelly hose **126**. The kelly hose **126**, also known as a mud hose, is a flexible, steel-reinforced, high-pressure hose that delivers drilling fluid through the bore of the kelly **125** and down into the drill string **160**.

[0069] The kelly **125** includes a drive section **127**. The drive section **127** is non-circular in cross-section and conforms to an opening **128** longitudinally extending through a kelly drive bushing **129**. The kelly drive bushing **129** is part of a rotary table. The rotary table is a mechanically driven device that provides clockwise (as viewed from above) rotational force to the kelly **125** and connected drill string **160** to facilitate the process of drilling a borehole

105. Both linear and rotational movement may thus be imparted from the kelly **125** to the drill string **160**.

[0070] A platform **102** is provided for the derrick **120**. The platform **102** extends above the earth surface **101**. The platform **102** generally supports rig hands along with various components of drilling equipment such as a pumps, motors, gauges, a dope bucket, pipe lifting equipment and control equipment. The platform **102** also supports the rotary table.

[0071] It is understood that the platform **102** shown in **Figure 1** is somewhat schematic. It is also understood that the platform **102** is merely illustrative and that many designs for drilling rigs, both for onshore and for offshore operations, exist. The claims provided herein are not limited by the configuration and features of the drilling rig unless expressly stated in the claims.

[0072] Placed below the platform **102** and the kelly drive section **127** but above the earth surface **101** is a blow-out preventer, or BOP **130**. The BOP **130** is a large, specialized valve or set of valves used to control pressures during the drilling of oil and gas wells. Specifically, blowout preventers control the fluctuating pressures emanating from subterranean formations during a drilling process. The BOP **130** may include upper **132** and lower **134** rams used to isolate flow on the back side of the drill string **160**. Blowout preventers **130** also prevent the pipe joints making up the drill string **160** and the drilling fluid from being blown out of the wellbore **150** when a blowout threatens.

[0073] As shown in **Figure 1**, the wellbore **150** is being formed down into the subsurface formation **155**. In addition, the wellbore **150** is being shown as a deviated wellbore. Of course, this is merely illustrative as the wellbore **150** may be a vertical well or even a horizontal well, as shown later in **Figure 2**.

[0074] In drilling the wellbore **150**, a first string of casing **110** is placed down from the surface **101**. This is known as surface casing **110** or, in some instances (particularly offshore), conductor pipe. The surface casing **110** is secured within the formation **155** by a cement sheath. The cement sheath resides within an annular region **115** between the surface casing **110** and the surrounding formation **155**.

[0075] During the process of drilling and completing the wellbore **150**, additional strings of casing (not shown) will be provided. These may include intermediate casing strings and a final production casing string. For the final production casing, a liner may be employed, that is, a string of casing that is not tied back to the surface **101**.

[0076] As noted, the wellbore **150** is formed by using a bottom hole assembly **170**. The bottom-hole assembly **170** allows the operator to control or “steer” the direction or

orientation of the wellbore **150** as it is formed. In this instance, the bottom hole assembly **170** is known as a rotary steerable drilling system, or RSS.

[0077] The bottom hole assembly **170** will include a drill bit **172**. The drill bit **172** may be turned by rotating the drill string **160** from the platform **102**. Alternatively, the drill bit **172** may be turned by using so-called mud motors **174**. The mud motors **174** are mechanically coupled to and turn the nearby drill bit **172**. The mud motors **174** are used with stabilizers or bent subs **176** to impart an angular deviation to the drill bit **172**. This, in turn, deviates the well from its previous path in the desired azimuth and inclination.

[0078] There are several advantages to directional drilling. These primarily include the ability to complete a wellbore along a substantially horizontal axis of a subsurface formation, thereby exposing a substantially greater formation face. These also include the ability to penetrate into subsurface formations that are not located directly below the wellhead. This is particularly beneficial where an oil reservoir is located under an urban area or under a large body of water. Another benefit of directional drilling is the ability to group multiple wellheads on a single platform, such as for offshore drilling. Finally, directional drilling enables multiple laterals and/or sidetracks to be drilled from a single wellbore in order to maximize reservoir exposure and recovery of hydrocarbons.

[0079] The illustrative well site **100** also includes a sensor **178**. Here, the sensor **178** is part of the bottom hole assembly **170**. The sensor **178** may be, for example, a set of position sensors that is part of the electronics for a RSS. Alternatively or in addition, the sensor **178** may be a temperature sensor, a pressure sensor, or other sensor for detecting a downhole condition during drilling. Alternatively still, the sensor may be an induction log or gamma ray log or other log that detects fluid and/or geology downhole.

[0080] The sensor **178** is part of a MWD or a LWD assembly. It is observed that the sensor **178** is located above the mud motors **174**. This is a common practice for MWD assemblies. This allows the electronic components of the sensor **178** to be spaced apart from the high vibration and centrifugal forces acting on the bit **172**.

[0081] Where the sensor **178** is a set of position sensors, the sensors may include three inclinometer sensors and three environmental acceleration sensors. Ideally, a temperature sensor and a wear sensor will also be placed in the drill bit **172**. These signals are input into a multiplexer and transmitted.

[0082] It is desirable to send signals about the downhole condition back to an operator at the surface **101**. To do this, a telemetry system is used. As discussed above, various

telemetry systems are known in the industry. However, the well site **100** of **Figure 1** presents a telemetry system that utilizes a series of novel communications nodes **180** placed along the drill string **160**. These nodes **180** allow for the high speed transmission of wireless signals based on the *in situ* generation of acoustic waves.

[0083] The nodes first include a topside communications node **182**. The topside communications node **182** is placed closest to the surface **101**. The topside node **182** is configured to receive and/or transmit acoustic signals. The topside communications node can be preferably above grade and on the wellhead.

[0084] The nodes may also include a sensor communications node **184**. The sensor communications node is placed closest to the sensor **178**. The sensor communications node **184** is configured to communicate with the downhole sensor **178**, and then send a wireless signal using an acoustic wave.

[0085] Finally, the nodes include a plurality of intermediate communications nodes **180**. Each of the intermediate communications nodes **180** resides between the sensor node **182** and the topside node **184**. The intermediate communications nodes **180** are configured to receive and then relay acoustic signals along the length of the wellbore **150**. Preferably, the intermediate communications nodes **180** utilize two-way electro-acoustic transducers to both receive and relay mechanical waves. In one embodiment, the sensor communications node is fully housed with the intermediate communications node.

[0086] In **Figure 1**, the nodes **180** are shown schematically. However, **Figure 3** offers an enlarged perspective view of an illustrative pipe joint **300**, along with an illustrative intermediate communications node **350**. The illustrative communications node **350** is shown exploded away from the pipe joint **300**.

[0087] In **Figure 3**, the pipe joint **300** is intended to represent a joint of drill pipe. However, the pipe joint **300** may be any other tubular body such as a joint of tubing or a portion of pipeline. The pipe joint **300** has an elongated wall **310** defining an internal bore **315**. The bore **315** transmits drilling fluids such as an oil based mud, or OBM, during a drilling operation. The pipe joint **300** has a box end **322** having internal threads, and a pin end **324** having external threads.

[0088] As noted, an illustrative intermediate communications node **350** is shown exploded away from the pipe joint **300**. The communications node **350** is designed to attach to the wall **310** of the pipe joint **300** at a selected location. In one aspect, selected pipe joints **300** will each have an intermediate communications node **350** between the box end **322** and the pin end **324**. In one arrangement, the communications node **350** is placed immediately

adjacent the box end **322** or, alternatively, immediately adjacent the pin end **324** of every joint of pipe. In another arrangement, the communications node **350** is placed at a selected location along every second or every third pipe joint **300** in a drill string **160**. In other aspects, more or less than one intermediate communications node may be placed per joint **300**.

[0089] The intermediate communications node **350** shown in **Figure 3** is designed to be pre-welded onto the wall **310** of the pipe joint **300**. However, it is preferred that the communications node **350** be configured to be selectively attachable to/detachable from a pipe joint **300** by mechanical means at a well site. This may be done, for example, through the use of clamps. Such a clamping system is shown at **600** in **Figure 6**, described more fully below. Alternatively, an epoxy or other suitable acoustic couplant may be used for chemical bonding. In any instance, the communications node **350** is an independent wireless communications device that is designed to be attached to an external surface of a well pipe, a coupling or a liner.

[0090] There are several benefits to the use of an externally-placed communications node that uses acoustic waves. For example, such a node will not interfere with the flow of fluids within the internal bore **315** of the pipe joint **300**. Further, installation and mechanical attachment can be readily assessed or adjusted, as necessary. Because the acoustic signals are carried principally by the wall **310** of the pipe joint **300** itself, the MFSK data content is largely unaffected by the fluids in the pipe joint **300**.

[0091] In **Figure 3**, the intermediate communications node **350** includes an elongated body **351**. The body **351** supports one or more batteries, shown schematically at **352**. The body **351** also supports an electro-acoustic transducer, shown schematically at **354**. In a preferred embodiment, the electro-acoustic transducer **354** may be a two-way transceiver that can both receive and transmit acoustic signals. The communications node **350** is intended to represent the communications nodes **180** of **Figure 1**, in one embodiment. The two-way electro-acoustic transducer **354** in each node **180** allows acoustic signals to be sent from node-to-node, either up the wellbore **150** or down the wellbore **150**.

[0092] Returning to **Figure 1**, in operation, the sensor communications node **184** is in electrical communication with the sensor **178**. This may be by means of a short wire, or by means of wireless communication such as infrared or radio-frequency communication. The sensor communications node **184** is configured to receive signals from the sensor **178**, wherein the signals represent a subsurface condition such as position, temperature, pressure, resistivity, or other formation data. Preferably, the sensor is contained in the same housing as

the sensor communications node **184**. Indeed, the sensor may be the same electro-acoustic transducer that enables the telemetry communication.

[0093] The sensor communications node **184** transmits signals from the sensor **178** as acoustic waves. The acoustic waves are preferably at a frequency of between about 50 kHz and 500 kHz. The signals are received by an intermediate communications node **180** that is closest to the sensor communications node **184**. That intermediate communications node **180**, in turn, will relay the signal on to a next-closest node **180** so that acoustic waves indicative of the downhole condition are sent from node-to-node. A last intermediate communications node **180** transmits the signals acoustically to the topside communications node **182**.

[0094] Communication may be between adjacent nodes, or it may occasionally skip a node depending on node spacing or communication range. Preferably, communication is routed around any nodes that are broken. Preferably, the number of nodes which transmit a communication packet is fewer than the total number of nodes between the sensor node and the topside node in order to conserve battery power and extend the operational life of the network.

[0095] The well site **100** of **Figure 1** also shows a receiver **190**. The receiver **190** comprises a processor **192** that receives signals sent from the topside communications node **182**. The signals may be received through a wire (not shown) such as a co-axial cable, a fiber optic cable, a USB cable, or other electrical or optical communications wire. Alternatively, the receiver **190** may receive signals from the topside communications node **182** wirelessly through a modem, a transceiver or other wireless communications link. The receiver **190** preferably receives electrical signals via a so-called Class I, Division 1 conduit, that is, a housing for wiring that is considered acceptably safe in an explosive environment. In some applications, radio, infrared or microwave signals may be utilized.

[0096] In any event, the processor **192** may be incorporated into a computer having a screen. The computer may have a separate keyboard **194**, as is typical for a desk-top computer, or an integral keyboard as is typical for a laptop or a personal digital assistant. In one aspect, the processor **192** is part of a multi-purpose “smart phone” having specific “apps” and wireless connectivity.

[0097] It is noted that data may be sent along the nodes not only from the sensor **178** up to the receiver **190**, but also from the receiver **190** down to the sensor **178**. This transmission may be of benefit in the event that the operator wishes to make a change in the way the sensor **178** is functioning. This is also of benefit when the sensor **178** is actually another type

of device, such as an inflow control device that opens, closes or otherwise actuates in response to a signal from the surface **101**.

[0098] **Figure 1** demonstrates the use of a wireless data telemetry system in connection with a drilling operation. However, the wireless downhole telemetry system may also be used for a completed well.

[0099] **Figure 2** is a cross-sectional view of an illustrative well site **200**. The well site **200** includes a wellbore **250** that penetrates into a subsurface formation **255**. The wellbore **250** has been completed as a cased-hole completion for producing hydrocarbon fluids. The well site **200** also includes a well head **260**. The well head **260** is positioned at an earth surface **201** to control and direct the flow of formation fluids from the subsurface formation **255** to the surface **201**.

[00100] Referring first to the well head **260**, the well head **260** may be any arrangement of pipes or valves that receive reservoir fluids at the top of the well. In the arrangement of **Figure 2**, the well head **260** is a so-called Christmas tree. A Christmas tree is typically used when the subsurface formation **255** has enough *in situ* pressure to drive production fluids from the formation **255**, up the wellbore **250**, and to the surface **201**. The illustrative well head **260** includes a top valve **262** and a bottom valve **264**. In some contexts, these valves are referred to as “master fracture valves.” Other valves may also be used.

[00101] It is understood that rather than using a Christmas tree, the well head **260** may alternatively include a motor (or prime mover) at the surface **201** that drives a pump. The pump, in turn, reciprocates a set of sucker rods and a connected positive displacement pump (not shown) downhole. The pump may be, for example, a rocking beam unit or a hydraulic piston pumping unit. Alternatively still, the well head **260** may be configured to support a string of production tubing having a downhole electric submersible pump, a gas lift valve, or other means of artificial lift (not shown). The present inventions are not limited by the configuration of operating equipment at the surface unless expressly noted in the claims.

[00102] Referring next to the wellbore **250**, the wellbore **250** has been completed with a series of pipe strings, referred to as casing. First, a string of surface casing **210** has been cemented into the formation. Cement is shown in an annular bore between the bore wall **215** of the wellbore **250** and the casing **210**. The surface casing **210** has an upper end in sealed connection with the lower master valve **264**.

[00103] Next, at least one intermediate string of casing **220** is cemented into the wellbore **250**. The intermediate string of casing **220** is in sealed fluid communication with the upper master valve **262**. Cement is again shown in a bore **215** of the wellbore **250**. The

combination of the casing strings **210, 220** and the cement sheath in the bore **215** strengthens the wellbore **250** and facilitates the isolation of formations behind the casing **210, 220**.

[00104] It is understood that a wellbore **250** may, and typically will, include more than one string of intermediate casing. Some of the intermediate casing strings may be only partially cemented into place, depending on regulatory requirements and the presence of migratory fluids in any adjacent strata.

[00105] Finally, a production liner **230** is provided. The production liner **230** is hung from the intermediate casing string **230** using a liner hanger **232**. A portion of the production liner **230** may optionally be cemented in place. The liner is a string of casing that is not tied back to the surface **201**.

[00106] The production liner **230** has a lower end **234** that extends substantially to an end **254** of the wellbore **250**. For this reason, the wellbore **250** is said to be completed as a cased-hole well. Those of ordinary skill in the art will understand that for production purposes, the liner **230** may be perforated or may include sections of slotted liner to create fluid communication between a bore **235** of the liner **230** and the surrounding rock matrix making up the subsurface formation **255**.

[00107] As an alternative, portions of the liner **230** may include joints of sand screen (not shown). The use of sand screens with gravel packs allows for greater fluid communication between the bore **235** of the liner **230** and the surrounding rock matrix while still providing support for the wellbore **250**. The present inventions are not limited by the nature of the completion unless expressly so stated in the claims.

[00108] The wellbore **250** also includes a string of production tubing **240**. The production tubing **240** extends from the well head **260** down to the subsurface formation **255**. In the arrangement of **Figure 2**, the production tubing **240** terminates proximate an upper end of the subsurface formation **255**. A production packer **242** is provided at a lower end of the production tubing **240** to seal off an annular region **245** between the tubing **240** and the surrounding production liner **230**. However, the production tubing **240** may extend closer to the end **234** of the liner **230**.

[00109] It is also noted that the bottom end **234** of the production liner **230** is completed substantially horizontally within the subsurface formation **255**. This is a common orientation for wells that are completed in so-called “tight” or “unconventional” formations. However, the present inventions have equal utility in vertically completed wells or in multi-lateral deviated wells. Further, the communications nodes **280** themselves may be used in other tubular constructions such as above-ground, under-ground, or below water pipelines.

[00110] The illustrative well site **200** also includes one or more sensors **290**. Here, the sensors **290** are placed at the depth of the subsurface formation **255**. The sensors **290** may be, for example, pressure sensors, flow meters, electrical impedance sensors, resistivity sensors, chemical sensors, pH sensors, or temperature sensors. A pressure sensor may be, for example, a sapphire gauge or a quartz gauge. Sapphire gauges are preferred as they are considered more rugged for the high-temperature downhole environment. Alternatively, the sensors may be microphones for detecting ambient noise, or geophones (such as a tri-axial geophone) for detecting the presence of micro-seismic activity. Alternatively still, the sensors may be fluid flow measurement devices such as a spinners, or fluid composition sensors.

[00111] It is desirable to send signals about the downhole condition back to a receiver at the surface **201**. As with the well site **100** of **Figure 1**, the well site **200** of **Figure 2** includes a telemetry system that utilizes a series of novel communications nodes. Here, the communications nodes are placed along the outer diameter of the string of production tubing **240**. These nodes allow for the high speed transmission of wireless signals based on the *in situ* generation of acoustic waves.

[00112] The nodes first include a topside communications node **282**. The topside communications node **282** is placed closest to the surface **201**. The topside node **282** is configured to receive and/or transmit signals. The topside communications node **282** should be placed on the wellhead or next to the surface along the uppermost joint of casing **210**.

[00113] The nodes also include a sensor communications node **284**. The sensor communications node **284** is placed closest to the sensors **290**. The sensor communications node **284** is configured to communicate with the downhole sensor **290**, and then send a wireless signal using acoustic waves.

[00114] Finally, the nodes include a plurality of intermediate communications nodes **280**. Each of the intermediate communications nodes **280** resides between the sensor communications node **284** and the topside communications node **282**. The intermediate communications nodes **280** are configured to receive and then relay acoustic signals along the length of the tubing string **240**. Preferably, the intermediate nodes **280** utilize two-way electro-acoustic transducers to receive and relay mechanical waves. The intermediate communications nodes **280** preferably reside along an outer diameter of the casing strings **210, 220, 230**.

[00115] In operation, the sensor communications node **284** is in electrical communication with the (one or more) sensors **290**. This may be by means of a short wire, or by means of

wireless communication such as infrared or radio waves. The sensor communications node **284** is configured to receive signals from the sensors **290**, wherein the signals represent a subsurface condition such as temperature or pressure. Alternatively, sensor **290** may be contained in the housing of communications node **284**.

[00116] The sensor communications node **284** transmits signals from the sensors **290** as acoustic waves. The acoustic waves are preferably at a frequency band of about 50 to 100 kHz. The signals are received by an intermediate communications node **280**. That intermediate communications node **280**, in turn, will relay the signal on to another intermediate communications node so that acoustic waves indicative of the downhole condition are sent from node-to-node. A last intermediate communications node **280** transmits the signals to the topside node **282**.

[00117] The well site **200** of **Figure 2** shows a receiver **270**. The receiver **270** comprises a processor **272** that receives signals sent from the topside communications node **284**. The receiver **270** may include a screen and a keyboard **274** (either as a keypad or as part of a touch screen). The receiver **270** may also be an embedded controller with neither screen nor keyboard which communicates with a remote computer via cellular modem or telephone lines.

[00118] The signals may be received by the processor **272** through a wire (not shown) such as a co-axial cable, a fiber optic cable, a USB cable, or other electrical or optical communications wire. Alternatively, the receiver **270** may receive the final signals from the topside node **282** wirelessly through a modem or transceiver. The receiver **270** preferably receives electrical signals via a so-called Class I, Division 1 conduit, that is, a wiring conduit that is considered acceptably safe in an explosive environment.

[00119] **Figures 1** and **2** present illustrative wellbores **150**, **250** having a downhole telemetry system that uses a series of acoustic transducers. In each of **Figures 1** and **2**, the top of the drawing page is intended to be toward the surface and the bottom of the drawing page toward the well bottom. While wells commonly are completed in substantially vertical orientation, it is understood that wells may also be inclined and even horizontally completed. When the descriptive terms “up” and “down” or “upper” and “lower” or similar terms are used in reference to a drawing, they are intended to indicate relative location on the drawing page, and not necessarily orientation in the ground, as the present inventions have utility no matter how the wellbore is orientated.

[00120] In each of **Figures 1** and **2**, the communications nodes **180**, **280** are specially designed to withstand the same corrosive and environmental conditions (i.e., high

temperature, high pressure) of a wellbore **150** or **250** as the casing strings, drill string, or production tubing. To do so, it is preferred that the communications nodes **180**, **280** include sealed steel housings for holding the electronics.

[00121] **Figure 4A** is a perspective view of a communications node **400** as may be used in the wireless data transmission systems of **Figure 1** or **Figure 2** (or other wellbore), in one embodiment. The communications node **400** may be an intermediate communications node that is designed to provide two-way communication using a transceiver within a novel downhole housing assembly. **Figure 4B** is a cross-sectional view of the communications node **400** of **Figure 4A**. The view is taken along the longitudinal axis of the node **400**. The communications node **400** will be discussed with reference to **Figures 4A** and **4B**, together.

[00122] The communications node **400** first includes a housing **410**. The housing **410** is designed to be attached to an outer wall of a joint of wellbore pipe, such as the pipe joint **300** of **Figure 3**. Where the wellbore pipe is a carbon steel pipe joint such as drill pipe, casing or liner, the housing is preferably fabricated from carbon steel. This metallurgical match avoids galvanic corrosion at the coupling.

[00123] The housing **410** is dimensioned to be strong enough to protect internal electronics. In one aspect, the housing **410** has an outer wall **412** that is about 0.2 inches (0.51 cm) in thickness. A bore **405** is formed within the wall **412**. The bore **405** houses the electronics, shown in **Figure 4B** as a battery **430** and a power supply wire **435**. An example of a battery suitable for the anticipated environment is one or more lithium primary cells.

[00124] The electronics of **Figure 4B** also include a transceiver **440** and a circuit board **445**. The circuit board **445** will preferably include a micro-processor or electronics module that processes acoustic signals. An electro-acoustic transducer **442** is provided to convert acoustical energy to electrical energy (or vice-versa) and is coupled with outer wall **412** on the side attached to the tubular body. The transducer **442** is in electrical communication with at least one sensor **432**.

[00125] It is noted that in **Figure 4B**, the sensor **432** resides within the housing **410** of the communications node **400**. However, as noted, the sensor **432** may reside external to the communications node **400**, such as above or below the node **400** along the wellbore. In **Figure 4C**, a dashed line is provided showing an extended connection between the sensor **432** and the electro-acoustic transducer **442**.

[00126] The transceiver **440** will receive an acoustic telemetry signal. In one preferred embodiment, the acoustic telemetry data transfer is accomplished using multiple frequency shift keying (MFSK). Any extraneous noise in the signal is moderated by using well-known

conventional analog and/or digital signal processing methods. This noise removal and signal enhancement may involve conveying the acoustic signal through a signal conditioning circuit using, for example, a bandpass filter.

[00127] The transceiver will also produce acoustic telemetry signals. In one preferred embodiment, an electrical signal is delivered to an electromechanical transducer, such as through a driver circuit. In a preferred embodiment, the transducer is the same electro-acoustic transducer that originally received the MFSK data. The signal generated by the electro-acoustic transducer then passes through the housing **410** to the tubular body (such as production tubing **240**), and propagates along the tubular body to other communication nodes. The re-transmitted signal represents the same sensor data originally transmitted by sensor communications node **284**. In one aspect, the acoustic signal is generated and received by a magnetostrictive transducer comprising a coil wrapped around a core as the transceiver. In another aspect, the acoustic signal is generated and received by a piezo-electric ceramic transducer. In either case, the electrically encoded data are transformed into a sonic wave that is carried through the wall of the tubular body in the wellbore.

[00128] The communications node **400** optionally has a protective outer layer **425**. The protective outer layer **425** resides external to the wall **412** and provides an additional thin layer of protection for the electronics. The communications node **400** is also preferably fluid sealed with the housing **410** to protect the internal electronics. Additional protection for the internal electronics is available using an optional potting material.

[00129] The communications node **400** also optionally includes a shoe **500**. More specifically, the node **400** includes a pair of shoes **500** disposed at opposing ends of the wall **412**. Each of the shoes **500** provides a beveled face that helps prevent the node **400** from hanging up on an external tubular body or the surrounding earth formation, as the case may be, during run-in or pull-out. The shoes **500** may have a protective outer layer **422** and an optional cushioning material **424** (shown in **Figure 4A**) under the outer layer **422**.

[00130] **Figures 5A** and **5B** are perspective views of an illustrative shoe **500** as may be used on an end of the communications node **400** of **Figure 4A**, in one embodiment. In **Figure 5A**, the leading edge or front of the shoe **500** is seen, while in **Figure 5B** the back of the shoe **500** is seen.

[00131] The shoe **500** first includes a body **510**. The body **510** includes a flat under-surface **512** that butts up against opposing ends of the wall **412** of the intermediate communications node **400**.

[00132] Extending from the under-surface **512** is a stem **520**. The illustrative stem **520** is circular in profile. The stem **520** is dimensioned to be received within opposing recesses **414** of the wall **412** of the node **400**.

[00133] Extending in an opposing direction from the body **510** is a beveled surface **530**. As noted, the beveled surface **530** is designed to prevent the communications node **400** from hanging up on an object during run-in into a wellbore.

[00134] Behind the beveled surface **530** is a flat (or slightly curved) surface **535**. The flat surface **535** is configured to extend along the drill string **160** (or other tubular body) when the communications node **400** is attached along the tubular body. In one aspect, the shoe **500** includes an optional shoulder **515**. The shoulder **515** creates a clearance between the flat surface **535** and the tubular body opposite the stem **520**.

[00135] The shoes **500** are preferably attached to the body **410** of the node **400** by welding. Welding preferably takes place before the nodes are delivered to the well site to avoid the presence of sparks. In another arrangement, the shoes **500** are applied through a glue, or by using a threaded connection with gaskets.

[00136] In one arrangement, the communications nodes **400** with the shoes **500** are welded onto an inner or outer surface of the tubular body, such as wall **310** of the pipe joint **300**. More specifically, the body **410** of the respective communications nodes **400** are welded onto the wall of the tubular body. In some cases, it may not be feasible or desirable to pre-weld the communications nodes **400** onto pipe joints before delivery to a well site. Therefore, it is desirable to utilize a clamping system that allows a drilling or service company to mechanically connect / disconnect the communications nodes **400** along a tubular body as the tubular body is being run into a wellbore.

[00137] **Figure 6** is a perspective view of a communications node system **600** of the present invention, in one embodiment. The communications node system **600** utilizes a pair of clamps **610** for mechanically connecting an intermediate communications node **400** onto a tubular body **630**.

[00138] The system **600** first includes at least one clamp **610**. In the arrangement of **Figure 6**, a pair of clamps **610** is used. Each clamp **610** abuts the shoulder **515** of a respective shoe **500**. Further, each clamp **610** receives the base **535** of a shoe **500**. In this arrangement, the base **535** of each shoe **500** is welded onto an outer surface of the clamp **610**. In this way, the clamps **610** and the communications node **400** become an integral tool.

[00139] The illustrative clamps **610** of **Figure 6** include two arcuate sections **612**, **614**. The two sections **612**, **614** pivot relative to one another by means of a hinge. Hinges are shown in phantom at **615**. In this way, the clamps **610** may be selectively opened and closed.

[00140] Each clamp **610** also includes a fastening mechanism **620**. The fastening mechanisms **620** may be any means used for mechanically securing a ring onto a tubular body, such as a hook or a threaded connector. In the arrangement of **Figure 6**, the fastening mechanism is a threaded bolt **625**. The bolt **625** is received through a pair of rings **622**, **624**. The first ring **622** resides at an end of the first section **612** of the clamp **610**, while the second ring **624** resides at an end of the second section **614** of the clamp **610**. The threaded bolt **625** may be tightened by using, for example, one or more washers (not shown) and threaded nuts **627**.

[00141] In operation, a clamp **610** is placed onto the tubular body **630** by pivoting the first **612** and second **614** arcuate sections of the clamp **610** into an open position. The first **612** and second **614** sections are then closed around the tubular body **630**, and the bolt **625** is run through the first **622** and second **624** receiving rings. The bolt **625** is then turned relative to the nut **627** in order to tighten the clamp **610** and connected communications node **400** onto the outer surface of the tubular body **630**. Where two clamps **610** are used, this process is repeated.

[00142] The tubular body **630** may be, for example, a drill string such as the illustrative drill string **160** of **Figure 1**. Alternatively, the tubular body **630** may be a string of production tubing such as the tubing **240** of **Figure 2**. In any instance, the tubular body **630** is ideally fabricated from a steel material having a thickness which contributes to broadening a mechanical response of the electro-acoustic transducer in the intermediate communications node **400**, where the mechanical resonance is at a frequency contained within the frequency band used for telemetry.

[00143] In one aspect, the communications node **400** is about 12 to 20 inches (0.30 to 0.51 meters) in length as it resides along the tubular body **630**. Specifically, the housing **410** of the communications node may be 8 to 16 inches (0.20 to 0.41 meters) in length, and each opposing shoe **500** may be 2 to 5 inches (0.05 to 0.13 meters) in length. Further, the communications node **400** may be about 1 inch in width and 1 inch in height. The housing **410** of the communications node **400** may have a concave profile that generally matches the radius of the tubular body **630**.

[00144] A method for transmitting data in a wellbore is also provided herein. The method preferably employs the communications node **400** and the clamping system **600** of **Figure 6**.

[00145] **Figure 7** provides a flow chart for a method **700** of transmitting data in a wellbore. The method **700** uses a plurality of communications nodes situated along a tubular body to accomplish a wireless transmission of data along the wellbore. The wellbore penetrates into a subsurface formation, allowing for the communication of a wellbore condition at the level of the subsurface formation up to the surface.

[00146] The method **700** first includes running a tubular body into the wellbore. This is shown at Box **710**. The tubular body is formed by connecting a series of pipe joints end-to-end. The pipe joints are fabricated from a steel material that is suitable for conducting an acoustical signal.

[00147] The method **700** also includes placing at least one sensor along the wellbore at a depth of the subsurface formation. This is provided at Box **720**. Here, the sensor may be a pressure sensor, a temperature sensor, an inclinometer, a logging tool, a resistivity sensor, a vibration sensor, a fluid density sensor, a fluid identification sensor, a fluid flow measurement device (such as a so-called “spinner”) or other sensor. The sensor may reside, for example, along a string of drill pipe as part of a rotary steerable drilling system. Alternatively, the sensor may reside along a string of casing within a wellbore. Alternatively still, the sensor may reside along a string of production tubing or a joint of sand screen.

[00148] The method **700** further includes attaching a sensor communications node to the tubular body. This is seen at Box **730**. The sensor communications node may be placed either inside or outside of a tubular body. The sensor communications node is then placed at the depth of the subsurface formation. The sensor communications node is in communication with the at least one sensor. This is preferably a short wired connection or a connection through a circuit board. The sensor communications node is configured to receive signals from the at least one sensor. The signals represent a subsurface condition such as temperature, pressure, pipe strain, fluid flow or fluid composition, or geology.

[00149] Preferably, the at least one sensor resides within the housing for the sensor communications node. The sensor communications node may alternatively be configured to use the electro-acoustic transducer as a sensor.

[00150] The method **700** also provides for attaching a topside communications node to the tubular body. This is indicated at Box **740**. The topside communications node is attached to the tubular body proximate the surface. In one aspect, the topside communications node is connected to the well head, which for purposes of the present disclosure may be considered part of the tubular body.

[00151] The method **700** further comprises attaching a plurality of intermediate communications nodes to the tubular body. This is shown at Box **750**. The intermediate communications nodes reside in spaced-apart relation along the tubular body between the sensor communications node and the topside communications node. The intermediate communications nodes are configured to receive and transmit acoustic waves from the sensor communications node to the topside node. Each acoustic signal represents a packet of data comprised of a collection of separate tones.

[00152] In one aspect, piezo wafers or other piezoelectric elements are used to receive and transmit acoustic signals. In another aspect, multiple stacks of piezoelectric crystals or magnetostrictive devices are used. Signals are created by applying electrical signals of an appropriate frequency across one or more piezoelectric crystals, causing them to vibrate at a rate corresponding to the frequency of the desired acoustic signal. In another aspect, the transducers are rotated within the housing relative to the external tubular to generate acoustic waves that propagate along the tubular with minimum loss of amplitude or around the tubular with maximum sensitivity to parameters of interest of the cement sheath.

[00153] In the method **700**, each of the intermediate communications nodes has an independent power source. The independent power source may be, for example, batteries or a fuel cell. In addition, each of the intermediate communications nodes has a transducer. The transducer is preferably an electro-acoustic transducer with an associated transceiver that is designed to receive the acoustic waves and produce acoustic waves.

[00154] In one aspect, the data transmitted between the nodes is represented by acoustic waves according to a multiple frequency shift keying (MFSK) modulation method. Although MFSK is well-suited for this application, its use as an example is not intended to be limiting. It is known that various alternative forms of digital data modulation are available, for example, frequency shift keying (FSK), multi-frequency signaling (MF), phase shift keying (PSK), pulse position modulation (PPM), and on-off keying (OOK). In one embodiment, every 4 bits of data are represented by selecting one out of sixteen possible tones for broadcast.

[00155] Acoustic telemetry along tubulars is characterized by multi-path or reverberation which persists for a period of milliseconds. As a result, a transmitted tone of a few milliseconds duration determines the dominant received frequency for a time period of additional milliseconds. Preferably, the communication nodes determine the transmitted frequency by receiving or "listening to" the acoustic waves for a time period corresponding to the reverberation time, which is typically much longer than the transmission time. The tone

duration should be long enough that the frequency spectrum of the tone burst has negligible energy at the frequencies of neighboring tones, and the listening time must be long enough for the multipath to become substantially reduced in amplitude. In one embodiment, the tone duration is 2 ms, then the transmitter remains silent for 48 milliseconds before sending the next tone. The receiver, however, listens for $2 + 48 = 50$ ms to determine each transmitted frequency, utilizing the long reverberation time to make the frequency determination more certain. Beneficially, the energy required to transmit data is reduced by transmitting for a short period of time and exploiting the multi-path to extend the listening time during which the transmitted frequency may be detected.

[00156] In one embodiment, an MFSK modulation is employed where each tone is selected from an alphabet of 16 tones, so that it represents 4 bits of information. With a listening time of 50 ms, for example, the data rate is 80 bits per second.

[00157] The tones are selected to be within a frequency band where the signal is detectable above ambient and electronic noise at least two nodes away from the transmitter node so that if one node fails, it can be bypassed by transmitting data directly between its nearest neighbors above and below. In one example, the tones can be approximately evenly spaced in frequency but the tones may be spaced within a frequency band from about 50 kHz to about 500 kHz. More preferably, the tones are spaced within a frequency band approximately 20 kHz wide centered around 100kHz. The tones are preferably contiguous.

[00158] In one aspect, the tubular body is a drill string. In this instance, each of the intermediate communications nodes is preferably placed along an outer diameter of pipe joints making up the drill string. In another aspect, the tubular body is a casing string. In this instance, each of the intermediate communications nodes is placed along an outer surface of pipe joints making up the casing string. In yet another embodiment, the tubular body is a production string such as tubing. In this instance, each of the intermediate communications nodes may be placed along an outer diameter of pipe joints making up the production string.

[00159] In one aspect, the method **700** further includes transmitting a signal from the topside communications node to a receiver. This is shown at Box **760**. The topside communications node also comprises an independent power source, meaning that it does not also supply power to any other intermediate or sensor communications node. The independent power source may be either internal to or external to the topside communications node. Further, the topside communications node has an electro-acoustic transducer designed to receive the acoustic waves from one or more of the plurality of intermediate communications nodes, and transmit acoustic waves to the receiver as a new signal. Further,

the topside node includes a magnetically activated reed switch or other means to silence radio transmissions from the node without opening the Class 1 Div 1 housing.

[00160] The communication signal between the topside communications node and the receiver may be either a wired electrical signal or a wireless radio transmission. Alternatively, the signal may be an optical signal. In any instance, the signal represents a subsurface condition as transmitted by the sensor in the subsurface formation. The signals are received by the receiver, which has data acquisition capabilities. The receiver may employ either volatile or non-volatile memory. The data may then be analyzed at the surface.

[00161] As can be seen, a novel downhole telemetry system is provided, as well as a novel method for the wireless transmission of information using a plurality of data transmission nodes. The re-transmission process that takes place along the nodes not only provides a mechanism to remove signal noise, but also increases the signal amplitude. In the system, the repertoire of frequencies used by the nodes for communication, the amplitude of each frequency, the time duration for which each frequency is transmitted, and the time between signals may be optimized to find a balance between data transmission rate and energy used in data transmission.

[00162] In one embodiment, the tubular body is made up of joints of pipe that form a casing string. Some of the joints of pipe and the connected communications nodes may be surrounded by a cement sheath. Acoustic signals may be sent as a collection of tones, or message packets, through the casing string during drilling or during later production operations. The acoustic signals may also be used to interrogate cement properties such as density and porosity.

[00163] In one aspect, each communications node **280** will listen for one or more tones of a specific frequency that, individually or collectively, indicate the start of a message packet. This enables an asynchronous network communication.

[00164] **Figure 8** presents an example of a message packet **800**. In this example, the message packet first consists of one or more start tones **805**. The start tone(s) **805** is followed by one or more tones **810** identifying a next node to receive the message packet **800**. The next tone **810** is followed by one or more tones **815** identifying the final node to receive the message packet **800**.

[00165] One or more additional tones **820** are provided in **Figure 8** that follow the final tone **815**. The tones **820** indicate the length of the data to be included in the message packet **800**. The data length tones **820** are then followed by a corresponding number of data tones **825**. These tones **825** represent the data portion of the message packet **800**. The data portion

(tones **825**) of the message packet **800** typically contains a command **827** followed by one or more associated related parameters **829**.

[00166] The message packet **800** finally includes one or more tones **830** used by the receiving node to validate a correct receipt of the message packet **800**. This may be done via a checksum calculation, a cyclic redundancy check (CRC), or some other means of error detection.

[00167] In operation, a communications node creates and transmits a message packet **800** with the start tone **805**. The next node tones **810** identified in the packet **800** receives the message packet **800**, replaces the next node tone **810** in the message packet **800** with the identifier for a communications node typically closer to the final node identified in the message packet **800** by final tone **815**. The communications node then transmits the changed message packet. This process continues until the communications node receiving the message packet **800** is the final node as identified in the message packet **800**. The final node typically acts on the message packet **800** and transmits a reply in the form of a new message packet identifying a different final node.

[00168] After sending a message packet **800**, the transmitting node preferably listens for the receiving node to transmit the new message packet. The new message packet typically represents a modified version of the original message packet, or a reply to the original message packet. Note that the new message packet is not necessarily addressed to the node that originated the message. If the transmitting node does not hear the receiving node transmit a new message packet, it resends the original message packet to the receiving node. This protocol facilitates detection of a lost message packet (a message packet transmitted but not received) and increases the likelihood of successful transmission of a message packet to a receiving node.

[00169] In order to change communication specifications such as tonal frequencies, tone transmission duration, waiting time between tones, and tonal amplitude, a “bi-lingual” command may be sent. This command enables pairs of nodes to temporarily transmit and receive using both the original communication protocol and an adjusted communication protocol. If only a subset of nodes is to be changed, this bi-lingual capability must be maintained at each interface. This procedure requires the simultaneous use of two sets of communication specifications.

[00170] In one aspect, each communications node will alternate between being awake (an awake state) and being asleep (a sleep state). In the awake state, a node is able to communicate; in the sleep state, the node is unable to transmit, although it is able to collect

data. In the sleep state, the node is periodically able to receive a wakeup packet causing it to return to the awake state. In the sleep state, the node is also periodically able to receive a wait stub, causing it to listen for an additional amount of time for another wait stub or for a wakeup packet. The purpose of placing the node into sleep state is to place the electronics in a state of low power consumption. This multi-state capability, in turn, extends battery life.

[00171] In one embodiment, each communications node will operate in one of two states of operation: In the first state, called the sleep state, the node will sleep for a first period of time (typically a few minutes) and then wake up for a second period of time (typically a few seconds) to listen for incoming wait stubs or wakeup packets. If no wait stubs or wakeup packet is received, the node will return to its sleep state. This cycle will be repeated during the sleep state. In the second state, called the awake state, the node is always awake. A node will change state if it receives a message packet (while awake) instructing it to change state.

[00172] Preferentially, the communication protocol defines a wait stub which is short in duration compared to typical message packets that may be sent. **Figure 9** is an example of a sleep-to-wake transition using wait stubs **905** and a wakeup packet **910**. In **Figure 9**, two nodes are shown as being in acoustic communication. The two nodes represent a servicing node **935** and a target node **940**. The target node **940** is initially in a sleep state **915** until being awoken into its awake state **930**.

[00173] It can be seen that the servicing node **935** has transmitted a series of wake stubs **905** to the target node **940**. The wait stubs **905** cause the target node **940**, which is periodically awake **920** while in its sleep state **915**, to remain awake temporarily for an additional period of time **925** (typically 15 seconds). During the temporarily awake times **925**, additional wait stubs **905** may be received, causing the target node **940** to stay awake for still additional periods of time **925**. A wakeup packet **910** may then be sent from the servicing node **935**, instructing the target node **940** to switch to its awake state **930**. In this state, the target node **940** will remain awake.

[00174] It is noted that the use of the wait stubs **905** to produce additional wake times **925** wherein a full length wakeup packet **910** may be received enables the periodic awake time while in sleep state **920** to be shorter. This, in turn, reduces the power consumption as compared to a protocol where the periodic awake time **920** in sleep state is long enough to receive a full wakeup packet **910**. The servicing node **935** may transmit wait stubs **905** to the intended target node **940** at regular intervals to cause the target node **940** to awaken sooner and more reliably than would have been otherwise possible. Likewise, a sleeping target node

940 does not need to send transmissions to indicate when it is able to receive a wakeup packet 910, thereby saving the energy otherwise needed to transmit such transmissions.

[00175] In one aspect, each communications node is optionally configured to transmit a message packet comprising a collection 800 of tones used in acoustic telemetry, such as 16 tones, and determine the amplitudes and reverberation times of each tone when receiving such a packet 800. The node can preferably use this information to minimize energy usage and maximize data rate while maintaining reliable communication. In one embodiment, a packet consisting of all of the tones of interest is sent directly (with no relay nodes) from a transmitter node to a receiver node. The receiving node and the transmitting node together form a pair of nodes.

[00176] The receiving node detects the received amplitude and reverberation time for each tone in the packet. The receiving node then sends the same data back to the transmitting node. The transmitting node adjusts its transmit energy so that the weakest tone will be received at the weakest signal amplitude for which communication is still robust. The transmitting node may further reduce the waiting time between tones to the smallest time required for the reverberation to substantially subside. The transmitting node may also instruct the receiving node that it has made these changes in the communication protocol. In some cases, the results of such an amplitude assessment may conclude that tonal amplitudes at one band edge are weaker than all the other tones. Such a finding may suggest a manual or automated shift in the frequency band for the tonal alphabet. The aforementioned bi-lingual capability can facilitate a frequency band shift.

[00177] In one embodiment, each communications node has a query capability so that only logged data which meet certain criteria is retrieved, for example, retrieving only the measurements from a particular sensor such as a thermistor or strain gauge or acoustic transducer, or retrieving only measurements which were collected within a particular time window, or retrieving only every Nth measurement where N is an integer greater than 1. This can reduce the necessary volume of data transmission from a servicing node, which can reduce the node's energy consumption and extend the node's effective life.

[00178] In another aspect, each node is configured to automatically discharge its batteries when certain criteria are met. In this way, consuming reactants in the battery that might otherwise create a risk to the node electronics or node housing by remaining unreacted within the battery for an extended period of time are removed. For example, a node may be configured to discharge lithium primary batteries on a certain date and time, thereby reacting the remaining lithium metal within the batteries and transforming it into more chemically

stable compounds. The criteria for discharging the batteries include reaching a certain date and time, the passing of a certain period of time since the last communication with the node, or observing a certain sensor measurement in a certain range, such as a temperature that exceeds some threshold, or observing a combination of sensor measurements that indicate that external or internal conditions have occurred that make it prudent to discharge the batteries.

[00179] Various forms of error correction may also be applied in the acoustic telecommunications network. An example of one form is presented here to account for the irregularity of the frequency response of acoustic transducers across the band used for telemetry. In this respect, some tones are produced and received more weakly than others. Successful telemetry requires that even the weakest tone be audible amidst the ambient noise. It is typically necessary to increase the transmit signal amplitudes of all tones until the very weakest tone becomes audible. As an alternative, each communications node may employ a sequence of redundant tones, with at least two of the tones differing in frequency, to represent each data value. By using a sequence of two or more redundant tones for each data value, the system can still communicate if one or more of the redundant tones happens to be particularly weak. The node preferentially combines detection statistics for each group of redundant tones to enable successful communication even in cases for which all the redundant tones in a group are particularly weak. Both redundancy and pooling of detection statistics make the communication more reliable.

[00180] In one embodiment, the electro-acoustic telemetry network of the present invention uses a sliding alphabet as a method of reducing adverse impact of reverberation during transmission and reception of message packets **800**. One way such adverse impact could occur involves the transmission of two successive tones that happen to be identical in frequency. Such a circumstance may lead to ambiguity for the receiving node **940** in distinguishing between a distinct second tone as opposed to reverberant noise from the first tone.

[00181] **Figure 10** presents an example of the use of a sliding alphabet in an multi-frequency shift keying (MFSK) process. In this figure, a message packet is shown in four forms. The first form is shown at **1050**; this is the sending node's original acoustic message. The second form is shown at **1060**; this is the sending node's modified message. The third form is shown at **1070**; this is the acoustic message received by the target node. Finally, the fourth form is shown at **1080**; this is the message as deconstructed by the target node.

[00182] In the example of **Figure 10**, messages are acoustic signals sent by a transceiver along a tubular body that represent a logical alphabet. The logical alphabet consists of integer values between, for example, 0 and 15, inclusive. This means that the message packets consist of a sequence of logical alphabet values, representing tones. In practice, each communications node in the network is configured to associate the same set of distinct frequencies with the same physical alphabet consisting of consecutive integer values, beginning with "0." This will allow for at least one excess value of the physical alphabet.

[00183] To transmit a message packet, a transmitting node iterates through the message packet's constituent logical alphabet values **1050** from beginning to end of the message packet. In each case, the transmitting node either transmits a physical alphabet value equal to the logical alphabet value when the logical alphabet value is less than the previously transmitted physical alphabet value, or transmits a physical alphabet value equal to the logical alphabet value +1 when the logical alphabet value is equal to or greater than the previously transmitted physical alphabet value **1060**. This technique is one example of a sliding alphabet algorithm.

[00184] The receiving node deconstructs the received message packet by combining the received physical alphabet values **1070** from beginning to end of the message packet, in each case assigning a logical alphabet value equal to the physical alphabet value when the physical alphabet value is less than the previous physical alphabet value, or assigning a logical alphabet value equal to the physical alphabet value -1 when the physical alphabet value is equal to or greater than the previous physical alphabet value **1080**. This deconstruction technique is one example of a complement to the sliding alphabet algorithm.

[00185] It is noted that a sliding alphabet incorporates both an algorithm and a complement to the algorithm. In essence, the algorithm encodes the message packet while the complement to the algorithm decodes a message packet encoded by that specific algorithm. Thus, the algorithm is an encoder, while the complement to the algorithm is a decoder.

[00186] In one embodiment, the method for modulating acoustic waves comprises the steps of:

generating a first set of tones from a first electro-acoustic transceiver, with each tone being associated with a defined frequency, and with each tone being associated with a logical alphabet value;

reviewing the first set of tones to determine if two consecutive tones have the same logical alphabet value;

if two consecutive tones do have the same logical alphabet value, modifying the first set of tones to provide that no two same tones are sent consecutively, thereby generating a modified first set of tones;

transmitting the modified first set of tones from the first electro-acoustic transceiver;

receiving the modified first set of tones from the first electro-acoustic transceiver at a second electro-acoustic transceiver as a message packet;

reviewing the modified first set of tones; and

deconstructing the modified first set of tones back to its original first set of tones.

[00187] In one aspect, the modifying step comprises determining whether a tone in the first set of tones is equal to or greater than an immediately preceding tone in the first set of tones and, if a tone in the first set of tones is equal to or greater than an immediately preceding tone in the first set of tones, increasing the logical alphabet value by a defined alphabet value. In this instance, the deconstruction step comprises determining whether a tone in the modified first set of tones is greater than an immediately preceding tone in the modified first set of tones and, if a tone in the modified first set of tones is equal to or greater than an immediately preceding tone in the modified first set of tones, decreasing the logical alphabet value by the defined alphabet value. Preferably, the defined alphabet value is a next higher frequency. However, the defined alphabet value may be any sum (such as $x + 2$), any difference (such as $x - 2$), or product (such as $x3$), or any algebraic formula (such as $x2 - 1$).

[00188] In another aspect, the modifying step comprises determining whether a tone in the first set of tones is equal to or less than an immediately preceding tone in the first set of tones and, if a tone in the first set of tones is equal to or less than an immediately preceding tone in the first set of tones, decreasing the logical alphabet value by a defined alphabet value. In this instance, the deconstruction step comprises determining whether a tone in the modified first set of tones is equal to or less than an immediately preceding tone in the modified first set of tones and, if a tone in the modified first set of tones is equal to or less than an immediately preceding tone in the modified first set of tones, increasing the logical alphabet value by the defined alphabet value. Preferably, the defined alphabet value is a next lower frequency.

[00189] In either instance, each of the first and second electro-acoustic transceivers may reside either in a wellbore or along a pipeline as part of a telemetry system.

[00190] While it will be apparent that the inventions herein described are well calculated to achieve the benefits and advantages set forth above, it will be appreciated that the

inventions are susceptible to modification, variation and change without departing from the spirit thereof.

CLAIMS

What is claimed is:

1. An electro-acoustic system for wireless telemetry along a tubular body, comprising:
 - a tubular body fabricated from steel;
 - at least one sensor disposed along the tubular body;
 - a sensor communications node placed along the tubular body and connected to a wall of the tubular body, the sensor communications node being in electrical communication with the at least one sensor and configured to receive signals from the at least one sensor, the signals representing a parameter associated with a subsurface location along the tubular body;
 - a topside communications node placed proximate a surface;
 - a plurality of intermediate communications nodes spaced along the tubular body and attached to an outer wall of the tubular body, the intermediate communications nodes configured to transmit acoustic waves from the sensor communications node to the topside communications node in node-to-node arrangement; and
 - a receiver at the surface configured to receive signals from the topside communications node;wherein each of the intermediate communications nodes comprises:
 - a sealed housing;
 - an independent power source residing within the housing; and
 - an electro-acoustic transducer and associated transceiver also residing within the housing designed to receive and re-transmit the acoustic waves, thereby providing communications telemetry; andwherein the acoustic waves represent asynchronous packets of information comprising a plurality of separate tones, with at least some of the acoustic waves being indicative of the parameter.
2. The electro-acoustic system of claim 1, wherein:
 - the surface is an earth surface; and
 - the tubular body is a pipe residing below ground.
3. The electro-acoustic system of claim 1, wherein:
 - the surface is a water surface; and
 - the tubular body is a pipe residing below the water surface.

4. The electro-acoustic system of claim 1, wherein:
 - the tubular body is comprised of pipe joints disposed in a wellbore, with the wellbore penetrating into a subsurface formation; and
 - the at least one sensor and the sensor communications node are disposed along the wellbore proximate a depth of the subsurface formation.

5. The electro-acoustic system of claim 4, wherein the parameter comprises temperature, pressure, fluid flow, strain, or geological information related to a rock matrix of the subsurface formation.

6. The electro-acoustic system of claim 4, wherein the at least one sensor comprises (i) a pressure sensor, (ii) a temperature sensor, (iii) an induction log, (iv) a gamma ray log, (v) a formation density sensor, (vi) a sonic velocity sensor, (vii) a vibration sensor, (viii) a resistivity sensor, (ix) a flow meter, (x) a microphone, (xi) a geophone, (xii) a chemical sensor, or (xiii) a set of position sensors.

7. The electro-acoustic system of claim 4, wherein:
 - the tubular body is a casing string;
 - at least some of the intermediate communications nodes are surrounded by a cement sheath; and
 - each of the intermediate communications nodes is attached to an outer surface of pipe joints making up the casing string.

8. The electro-acoustic system of claim 1, wherein (i) each of the plurality of separate tones has a different frequency, (ii) no two consecutive tones have the same frequency, or (iii) both.

9. The electro-acoustic system of claim 1, wherein:
 - adjacent intermediate communications nodes represent pairs of nodes;
 - a receiving node in the pair of nodes is configured to detect amplitude and/or reverberation time for each tone received in a packet from a transmitting node in the pair of nodes, and then return the packet to the transmitting node; and

the transmitting node is configured to adjust its transmitting energy or its frequency band so that a weakest tone in the packet as returned by the receiving node will be received at a weakest signal amplitude for which communication remains robust.

10. The electro-acoustic system of claim 9, wherein the transmitting node is further configured to:

reduce a waiting time between tones to a smallest time required for the reverberation to substantially subside;

instruct the receiving node that it has made any changes in the transmitting energy, the waiting time, or the frequency band.

11. The method of claim 9, wherein:

the transmitting node is further configured to instruct other intermediate communications nodes of the changes in the transmitting energy, changes in the frequency band, or changes in the waiting time.

12. The electro-acoustic system of claim 9, wherein:

each intermediate communications node is configured to selectively operate in either an awake state wherein the node is able to send and receive signals, or in a sleep state wherein the node is able to collect data but makes no transmissions; and

during the sleep state, each intermediate communications node is programmed to have a periodically awake mode where it listens for a wakeup packet to return the node to its awake state.

13. The electro-acoustic system of claim 1, wherein the at least one sensor:

- (i) resides in the housing of a sensor communications node, or
- (ii) resides external to the sensor communications node.

14. The electro-acoustic system of claim 1, wherein the acoustic waves provide data that is modulated by (i) a multiple frequency shift keying method, (ii) a frequency shift keying method, (iii) a multi-frequency signaling method, (iv) a phase shift keying method, (v) a pulse position modulation method, or (vi) an on-off keying method.

15. The electro-acoustic system of claim 1, wherein the intermediate communications nodes are spaced apart according to the length of the joints of pipe.
16. The electro-acoustic system of claim 1, wherein the intermediate communications nodes are spaced at about 10 to about 100 foot intervals.
17. The electro-acoustic system of claim 1, wherein:
the communications nodes transmit data representing the asynchronous packets of information at a rate exceeding about 50 bps; and
a frequency band for the acoustic wave transmission is about 25 KHz wide.
18. The electro-acoustic system of claim 1, wherein:
the transceivers listen for tones that are selected to be within a frequency band of about 25kHz centered around about 100 kHz; and
the signals are detectable at least two nodes away from a transmitting node.
19. The electro-acoustic system of claim 1, wherein:
each intermediate communications node listens for the acoustic waves for a longer time than the time for which the acoustic waves were generated by a previous intermediate communications node; and
the acoustic waves provide data that is modulated by a multiple frequency shift keying method where each tone is selected from a logical alphabet of at least 8 tones.
20. A method of transmitting data in a wellbore, comprising:
providing a sensor along the wellbore at a depth of a subsurface formation;
running joints of pipe into the wellbore, the joints of pipe being connected by threaded couplings;
attaching a series of communications nodes to the joints of pipe according to a pre-designated spacing, wherein adjacent communications nodes are configured to communicate by acoustic waves transmitted through the joints of pipe;
providing a receiver at a surface; and
sending signals from the sensor to the receiver via the series of communications nodes, with the signals being indicative of a subsurface condition;
wherein each of the communications nodes comprises:

a sealed housing;

an electro-acoustic transducer and associated transceiver residing within the housing configured to send and receive the acoustic waves between nodes as part of the signals; and

an independent power source also residing within the housing for providing power to the transceiver; and

wherein the acoustic waves represent asynchronous packets of information comprising a plurality of separate tones, with at least some of the acoustic waves being indicative of the parameter.

21. The method of claim 20, wherein (i) each of the plurality of separate tones has a different frequency, (ii) no two consecutive tones have the same frequency, or (iii) both.

22. The method of claim 20, wherein:

adjacent intermediate communications nodes represent pairs of nodes;

a receiving node in the pair of nodes is configured to detect amplitude and/or reverberation time for each tone received in a packet from a transmitting node in the pair of nodes, and then return the packet to the transmitting node; and

the transmitting node is configured to adjust its transmitting energy, its frequency band, or both, so that a weakest tone in the packet as returned by the receiving node will be received at a weakest signal amplitude for which communication remains robust.

23. The method of claim 22, wherein the transmitting node is further configured to:

reduce a waiting time between tones to a smallest time required for the reverberation to substantially subside; and

instruct the receiving node that it has made any changes in the transmitting energy, the frequency band or the waiting time.

24. The method of claim 23, wherein the transmitting node is further configured to instruct other intermediate communications nodes of the changes in the transmitting energy or the frequency band or the waiting time.

25. The method of claim 22, wherein:
each intermediate communications node is configured to selectively operate in either an awake state wherein the node is able to send and receive signals, or in a sleep state wherein the node is able to collect data but make no transmission; and
during the sleep state, each intermediate communications node is programmed to have a periodically awake mode where it listens for a wakeup packet to return the node to its awake state.
26. The method of claim 20, wherein the joints of pipe form a string of casing.
27. The method of claim 20, wherein the sensor is (i) a pressure sensor, (ii) a temperature sensor, (iii) an induction log, (iv) a gamma ray log, (v) a formation density sensor, (vi) a sonic velocity sensor, (vii) a vibration sensor, (viii) a resistivity sensor, (ix) a flow meter, (x) a microphone, (xi) a geophone, (xii) a chemical sensor, or (xiii) a set of position sensors.
28. The method of claim 20, wherein each of the communications nodes further comprises at least one clamp for radially attaching the communications node onto an outer surface of a joint of pipe.
29. The method of claim 28, wherein the at least one clamp comprises:
a first arcuate section;
a second arcuate section;
a hinge for pivotally connecting the first and second arcuate sections; and
a fastening mechanism for securing the first and second arcuate sections around an outer surface of the tubular body.
30. The method of claim 20, wherein:
the electro-acoustic transceivers receive acoustic waves at a frequency, and re-transmit the acoustic waves at the same frequency; and
the electro-acoustic transceivers listen for the acoustic waves for a longer time than the time for which the acoustic waves were generated by a previous communications node.
31. The method of claim 20, wherein the sensor resides in the housing of a sensor communications node, with the housing being fabricated from steel.

32. A method of transmitting data in a wellbore, comprising:

- running a tubular body into the wellbore, the wellbore penetrating into a subsurface formation and the tubular body being comprised of pipe joints;
- placing at least one sensor along the wellbore at a depth of the subsurface formation;
- attaching a sensor communications node to a wall of the tubular body proximate the depth of the subsurface formation, the sensor communications node being in communication with the at least one sensor and configured to receive signals from the at least one sensor, the signals representing a subsurface condition;
- providing a topside communications node proximate a surface of the wellbore; and
- attaching a plurality of intermediate communications nodes to a wall of the tubular body in spaced-apart relation, the intermediate communications nodes configured to transmit acoustic waves from the sensor communications node to the topside communications node in node-to-node arrangement;

wherein each of the intermediate communications nodes comprises:

- a sealed housing;
- an independent power source residing within the housing;
- an electro-acoustic transducer and associated transceiver also residing within the housing designed to receive the acoustic waves as asynchronous packets of information and re-transmit them after reverberation of the acoustic waves has substantially attenuated, with at least some of the acoustic waves correlating to the signals generated by the sensor and representing a subsurface condition; and

at least one clamp for radially attaching the communications node onto an outer surface of the tubular body.

33. The method of claim 32, wherein:

- the intermediate communications nodes transmit the acoustic waves at a rate exceeding about 50 bps; and
- (i) each of the plurality of separate tones has a different frequency, (ii) no two consecutive tones have the same frequency, or (iii) both.

34. The method of claim 32, wherein:

- the tubular body forms a string of casing;
- adjacent intermediate communications nodes represent pairs of nodes;

a receiving node in the pair of nodes is configured to detect amplitude and reverberation time for each tone received in a packet from a transmitting node in the pair of nodes, and then return the packet to the transmitting node; and

the transmitting node is configured to adjust its transmitting energy or its frequency band so that a weakest tone in the packet as returned by the receiving node will be received at a weakest signal amplitude for which communication remains robust.

35. The method of claim 33, wherein the transmitting node is further configured to:
- reduce a waiting time between tones to a smallest time required for the reverberation to substantially subside;
 - instruct the receiving node that it has made any changes in the transmitting energy, the frequency band or the waiting time; and
 - instruct other intermediate communications nodes of the changes in the transmitting energy, the frequency band or the waiting time.

36. The method of claim 35, further comprising:
- receiving signals from the topside communications node at a receiver; and
 - analyzing the signals.

37. The method of claim 33, wherein the step of attaching a plurality of intermediate communications nodes to the tubular body comprises clamping the intermediate communications nodes to an outer surface of the tubular body.

38. The method of claim 33, further comprising:
- sending a signal from the surface to discharge a battery in a selected intermediate communications node.

39. The method of claim 38, wherein the signal is sent in response to a reading from a sensor based on a subsurface parameter.

40. An electro-acoustic system for wireless telemetry along a pipeline, comprising:
- a tubular body fabricated from steel;
 - at least one sensor disposed along the tubular body;

a sensor communications node placed along the tubular body and connected to a wall of the tubular body, the sensor communications node being in electrical communication with the at least one sensor and configured to receive signals from the at least one sensor, the signals representing a parameter associated with a location along the tubular body;

a proximal communications node placed at a beginning location along the tubular body;

a plurality of intermediate communications nodes spaced along the tubular body and attached to an outer wall of the tubular body, the intermediate communications nodes configured to transmit acoustic waves from the sensor communications node to the proximal communications node in node-to-node arrangement; and

a receiver configured to receive signals from the proximal communications node;

wherein each of the intermediate communications nodes comprises:

a sealed housing;

an independent power source residing within the housing; and

an electro-acoustic transducer and associated transceiver also residing within the housing designed to receive and re-transmit the acoustic waves, thereby providing communications telemetry; and

wherein the acoustic waves represent packets of information comprising a plurality of separate tones, with at least some of the acoustic waves being indicative of the parameter.

41. The electro-acoustic telemetry system of claim 40, wherein (i) each of the plurality of separate tones has a different frequency, (ii) no two consecutive tones have the same frequency, or (iii) both.

42. The electro-acoustic telemetry system of claim 41, wherein the at least one sensor comprises (i) a pressure sensor, (ii) a temperature sensor, (iii) a sonic velocity sensor, (iv) a vibration sensor, (v) a flow meter; (vi) an electrical impedance sensor, (vii) a resistivity sensor; or (viii) a chemical sensor.

43. The electro-acoustic telemetry system of claim 41, wherein each of the intermediate communications nodes further comprises at least one clamp for radially attaching the communications node onto an outer surface of the tubular body.

44. The electro-acoustic telemetry system of claim 41, wherein:
adjacent intermediate communications nodes represent pairs of nodes;
a receiving node in the pair of nodes is configured to detect amplitude and reverberation time for each tone received in a packet from a transmitting node in the pair of nodes, and then return the packet to the transmitting node; and
the transmitting node is configured to adjust its transmitting energy or its frequency band so that a weakest tone in the packet as returned by the receiving node will be received at a weakest signal amplitude for which communication remains robust.
45. The electro-acoustic telemetry system of claim 44, wherein the transmitting node is further configured to:
reduce a waiting time between tones to a smallest time required for the reverberation to substantially subside;
instruct the receiving node that it has made any changes in the transmitting energy, the frequency band or the waiting time; and
instruct other intermediate communications nodes of the changes in the transmitting energy, the frequency band or the waiting time.
46. The electro-acoustic telemetry system of claim 41, wherein:
each intermediate communications node is configured to selectively operate in either an awake state wherein the node is able to send and receive signals, or in a sleep state wherein the node is able to collect data but make no transmissions.
47. A method for modulating acoustic waves using a multi-frequency shift keying (MFSK) process, comprising:
generating a first set of tones from a first electro-acoustic transceiver, each tone being associated with a defined frequency, and each tone being associated with a logical alphabet value;
reviewing the first set of tones to determine if two consecutive tones have the same logical alphabet value;
if two consecutive tones do have the same logical alphabet value, modifying the first set of tones to provide that no two same tones are sent consecutively, thereby generating a modified first set of tones;
transmitting the modified first set of tones from the first electro-acoustic transceiver;

receiving the modified first set of tones from the first electro-acoustic transceiver at a second electro-acoustic transceiver as a message packet;
reviewing the modified first set of tones; and
deconstructing the modified first set of tones back to its original first set of tones.

48. The method of claim 47, wherein:

the modifying step comprises determining whether a tone in the first set of tones is equal to or greater than an immediately preceding tone in the first set of tones and, if a tone in the first set of tones is equal to or greater than an immediately preceding tone in the first set of tones, increasing the logical alphabet value by a defined alphabet value; and

the deconstruction step comprises determining whether a tone in the modified first set of tones is greater than an immediately preceding tone in the modified first set of tones and, if a tone in the modified first set of tones is equal to or greater than an immediately preceding tone in the modified first set of tones, decreasing the logical alphabet value by the defined alphabet value.

49. The method of claim 48, wherein the defined alphabet value is a next higher frequency.

50. The method of claim 47, wherein:

the modifying step comprises determining whether a tone in the first set of tones is equal to or less than an immediately preceding tone in the first set of tones and, if a tone in the first set of tones is equal to or less than an immediately preceding tone in the first set of tones, decreasing the logical alphabet value by a defined alphabet value; and

the deconstruction step comprises determining whether a tone in the modified first set of tones is equal to or less than an immediately preceding tone in the modified first set of tones and, if a tone in the modified first set of tones is equal to or less than an immediately preceding tone in the modified first set of tones, increasing the logical alphabet value by the defined alphabet value.

51. The method of claim 50, wherein the defined alphabet value is a next lower frequency.

52. The method of claim 47, wherein each of the first and the second electro-acoustic transceivers resides either in a wellbore or along a pipeline as part of a telemetry system.

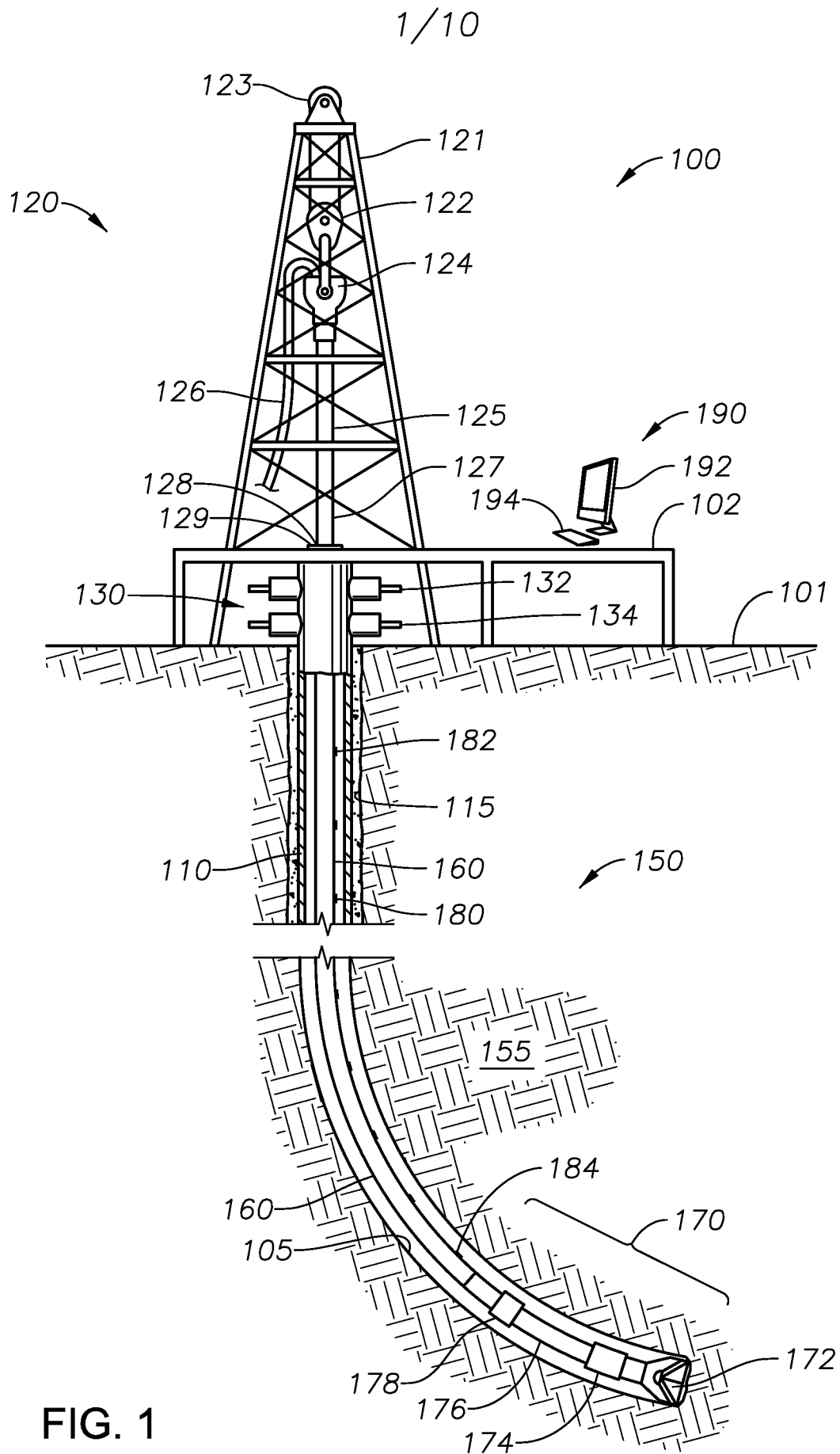
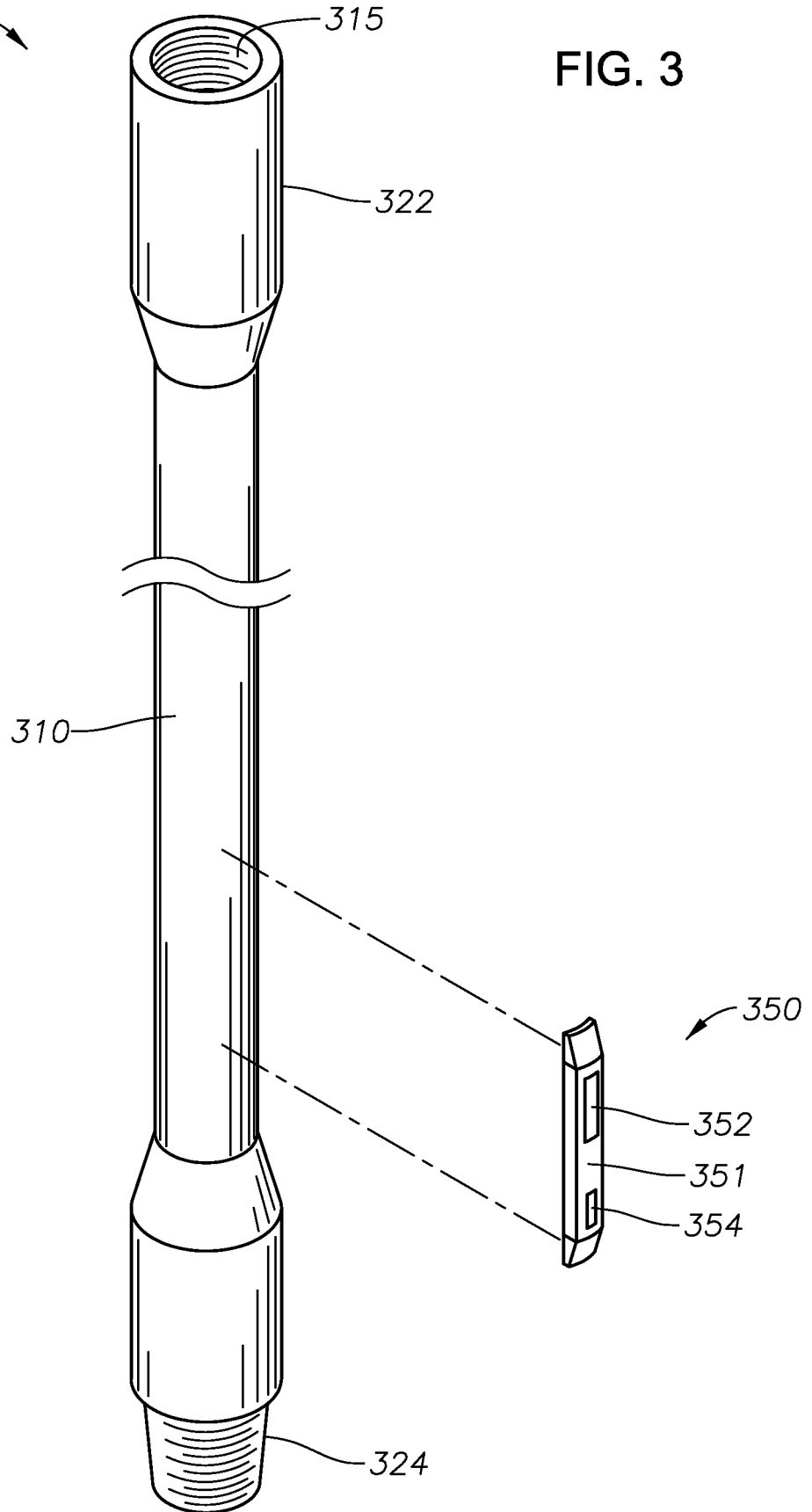

FIG. 1

3/10

300

FIG. 3



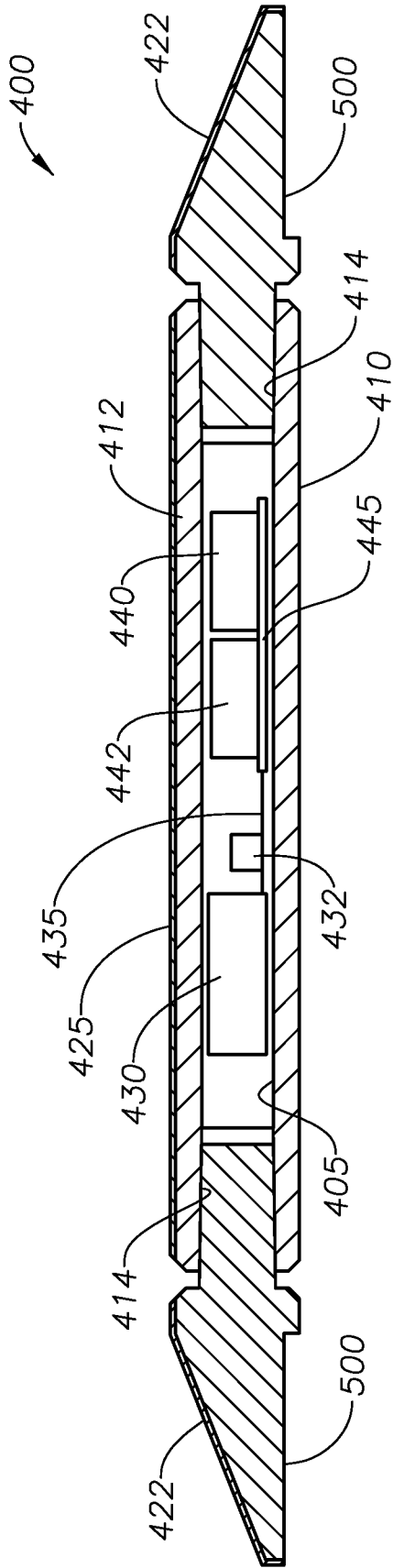

FIG. 4B

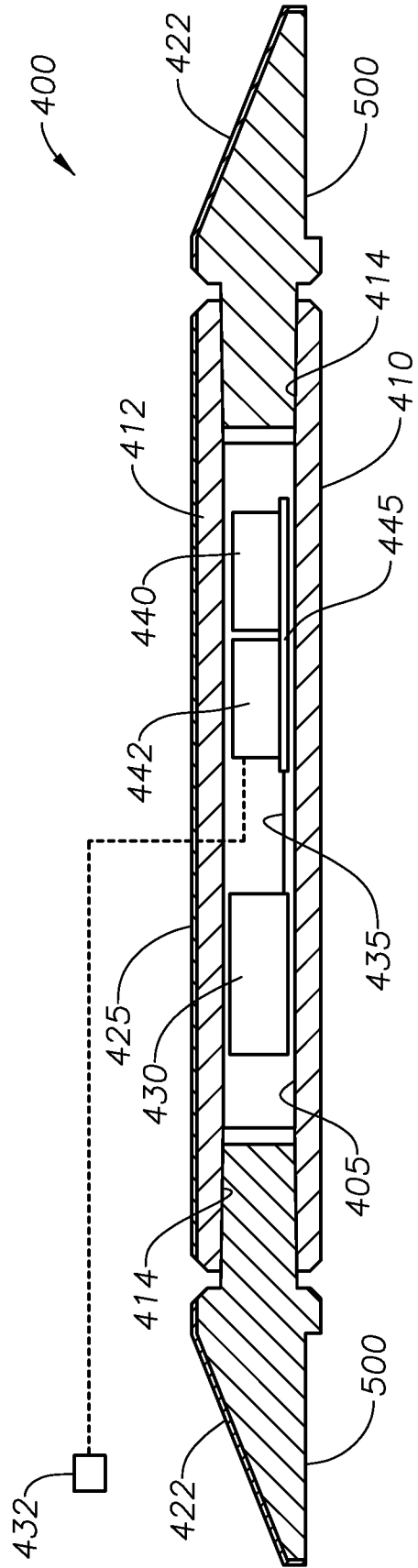

FIG. 4C

5/10

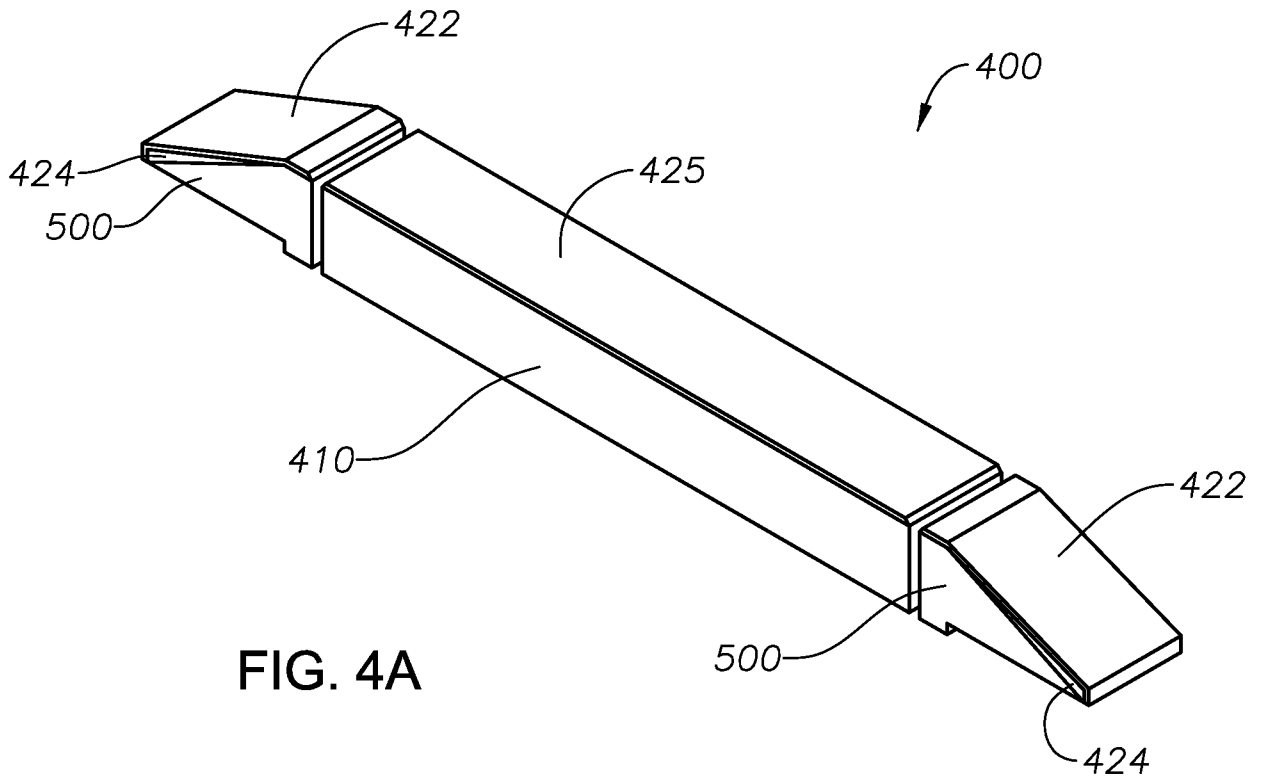

FIG. 4A

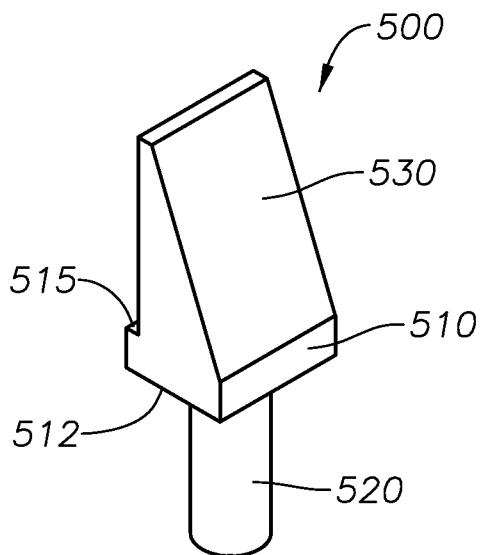

FIG. 5A

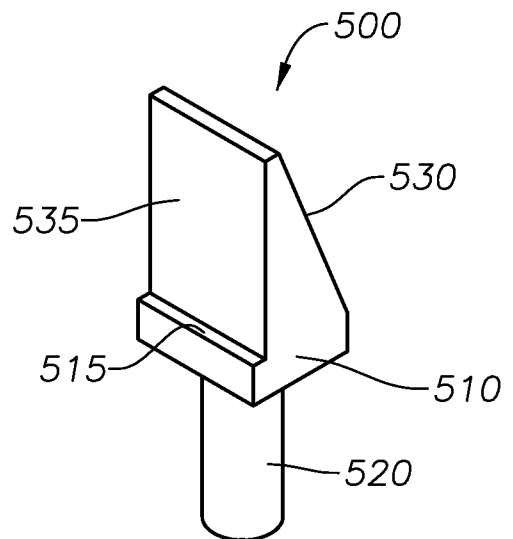

FIG. 5B

7/10

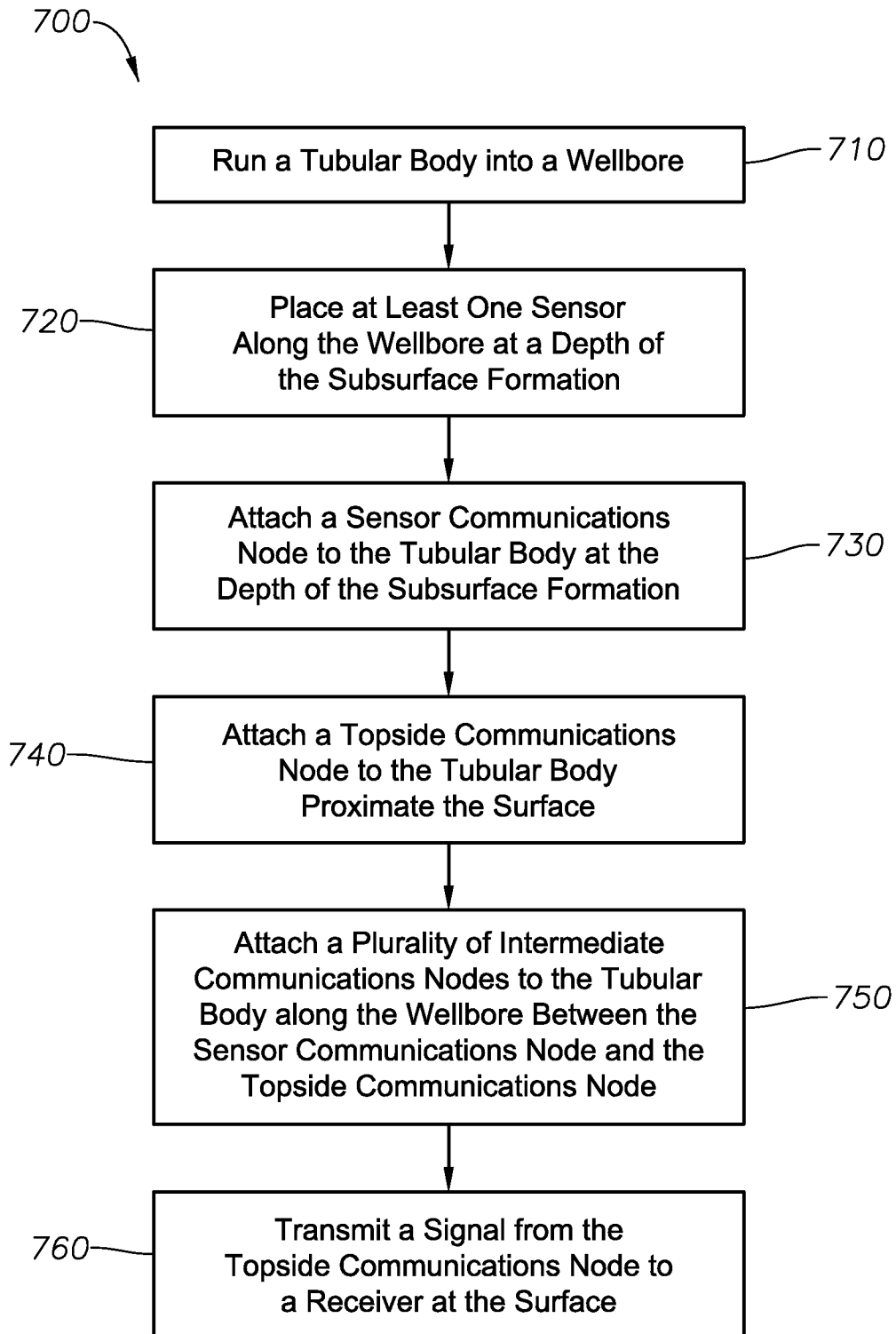

FIG. 7

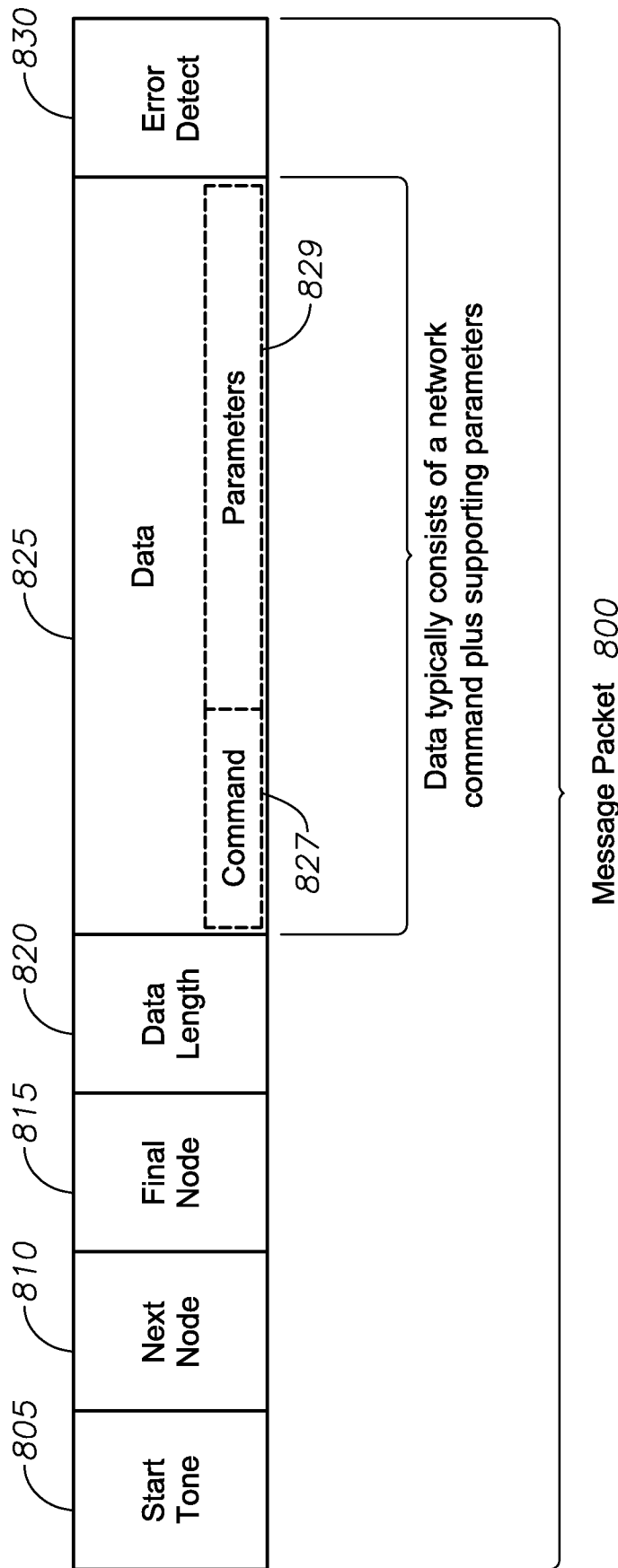

FIG. 8

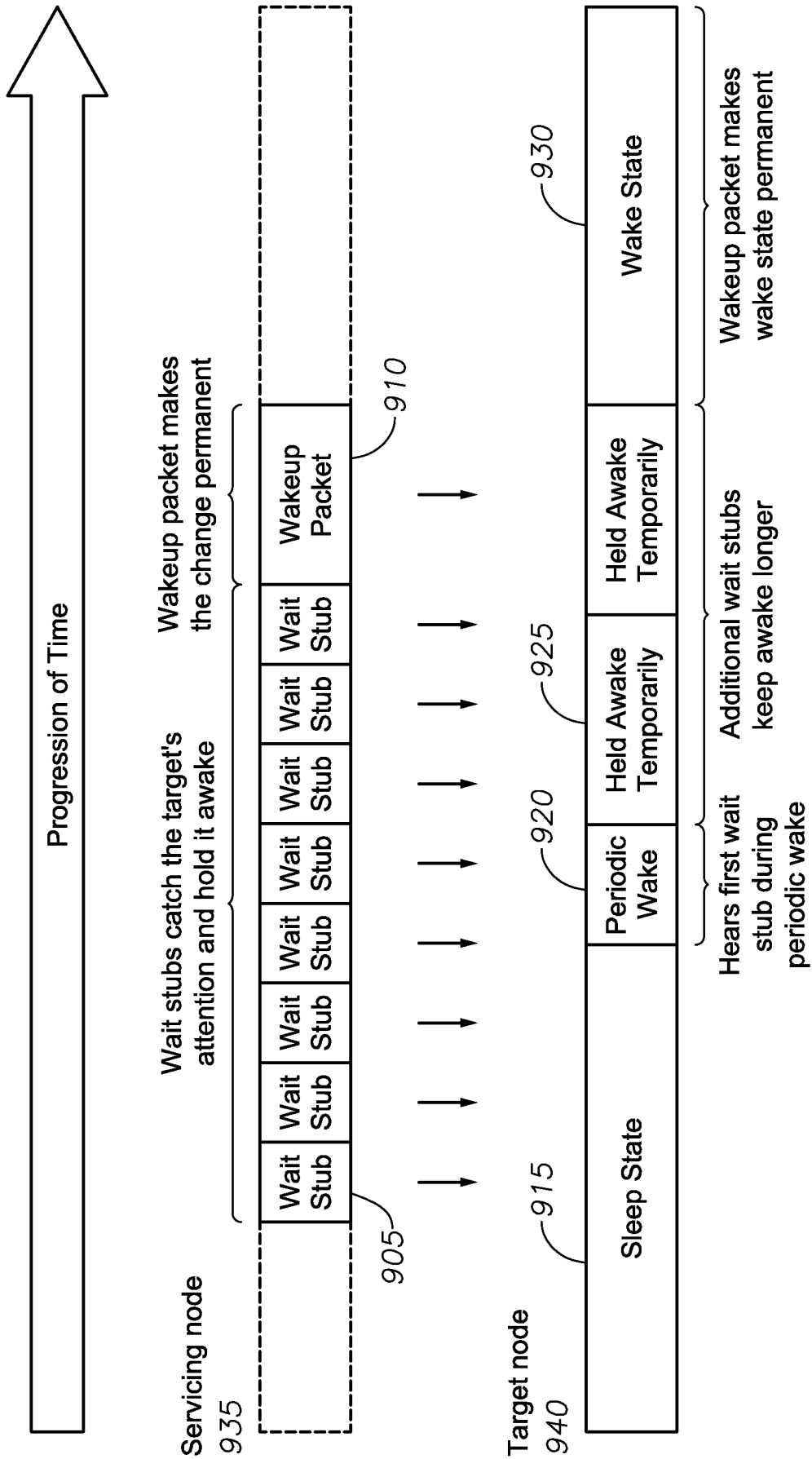

FIG. 9

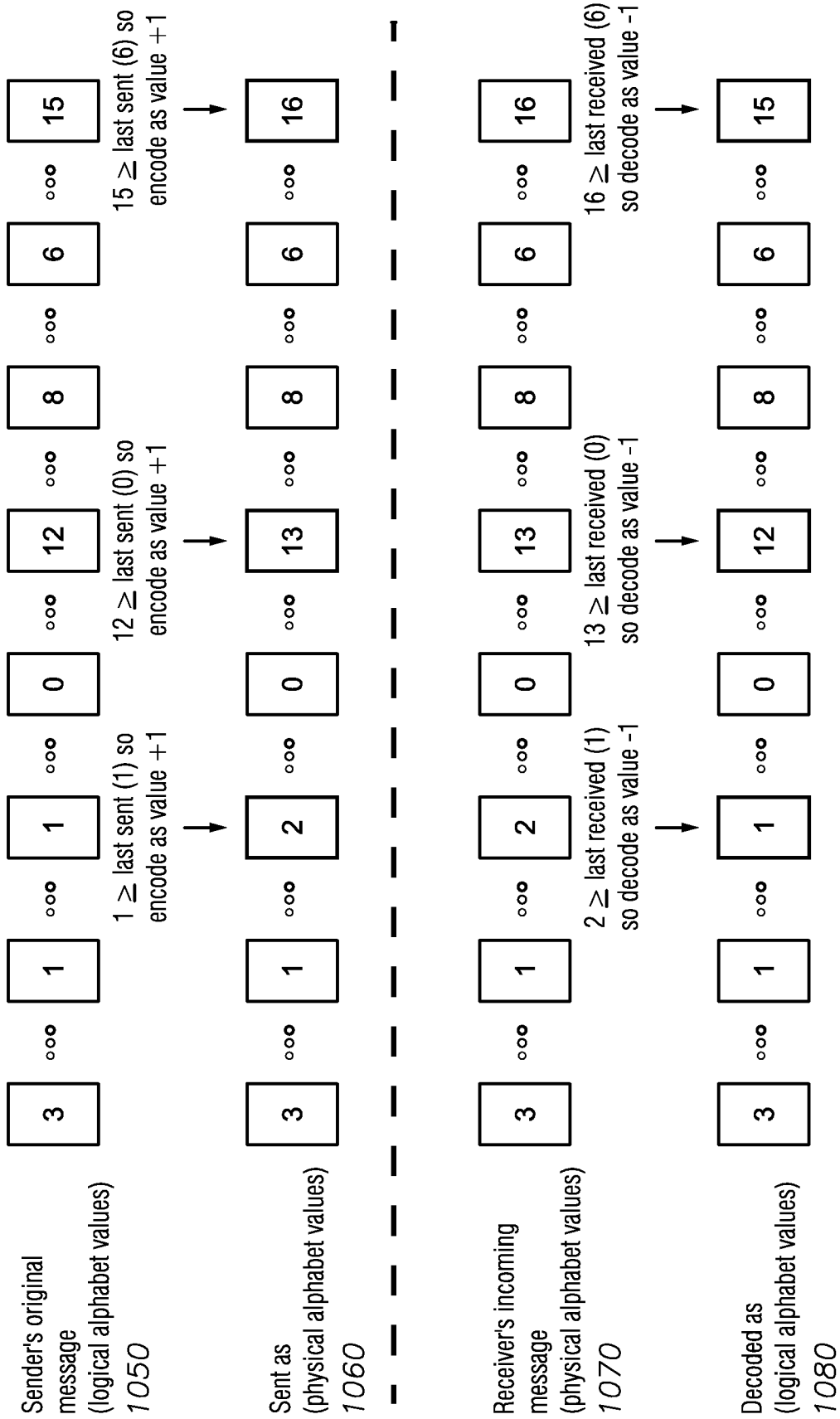

FIG. 10

INTERNATIONAL SEARCH REPORT

International application No.

PCT/US2013/076269

A. CLASSIFICATION OF SUBJECT MATTER

IPC(8) - E21B 47/00 (2014.01)

USPC - 340/853.1

According to International Patent Classification (IPC) or to both national classification and IPC

B. FIELDS SEARCHED

Minimum documentation searched (classification system followed by classification symbols)

IPC(8) - E21B 47/00, 47/12, 47/16 (2014.01)

USPC - 340/853.1, 854.4; 367/81, 82

Documentation searched other than minimum documentation to the extent that such documents are included in the fields searched
CPC - E21B 47/12, 47/16, 47/122 (2014.02)

Electronic data base consulted during the international search (name of data base and, where practicable, search terms used)

PatBase, Google Patents, Google Scholar

C. DOCUMENTS CONSIDERED TO BE RELEVANT

Category*	Citation of document, with indication, where appropriate, of the relevant passages	Relevant to claim No.
Y	US 5,850,369 A (RORDEN et al) 15 December 1998 (15.12.1998) entire document	1-46
Y	US 5,128,901 A (DRUMHELLER) 07 July 1992 (07.07.1992) entire document	1-46
Y	US 2005/0284659 A1 (HALL et al) 29 December 2005 (29.12.2005) entire document	20-31
Y	US 2009/0289808 A1 (PRAMMER) 26 November 2009 (26.11.2009) entire document	12,25,46
Y	US 5,924,499 A (BIRCHAK et al) 20 July 1999 (20.07.1999) entire document	38-39
Y	US 2004/0065443 A1 (BERG et al) 08 April 2004 (08.04.2004) entire document	29
A	EP 0636763 A2 (MEYER et al) 01 February 1995 (01.02.1995) entire document	1-46

 Further documents are listed in the continuation of Box C.

* Special categories of cited documents:

"A" document defining the general state of the art which is not considered to be of particular relevance

"E" earlier application or patent but published on or after the international filing date

"L" document which may throw doubts on priority claim(s) or which is cited to establish the publication date of another citation or other special reason (as specified)

"O" document referring to an oral disclosure, use, exhibition or other means

"P" document published prior to the international filing date but later than the priority date claimed

"T" later document published after the international filing date or priority date and not in conflict with the application but cited to understand the principle or theory underlying the invention

"X" document of particular relevance; the claimed invention cannot be considered novel or cannot be considered to involve an inventive step when the document is taken alone

"Y" document of particular relevance; the claimed invention cannot be considered to involve an inventive step when the document is combined with one or more other such documents, such combination being obvious to a person skilled in the art

"&" document member of the same patent family

Date of the actual completion of the international search

15 May 2014

Date of mailing of the international search report

27 MAY 2014

Name and mailing address of the ISA/US

Mail Stop PCT, Attn: ISA/US, Commissioner for Patents

P.O. Box 1450, Alexandria, Virginia 22313-1450

Facsimile No. 571-273-3201

Authorized officer:

Blaine R. Copenheaver

PCT Helpdesk: 571-272-4300

PCT OSP: 571-272-7774

INTERNATIONAL SEARCH REPORT

International application No.

PCT/US2013/076269

Box No. II Observations where certain claims were found unsearchable (Continuation of item 2 of first sheet)

This international search report has not been established in respect of certain claims under Article 17(2)(a) for the following reasons:

1. Claims Nos.:
because they relate to subject matter not required to be searched by this Authority, namely:

2. Claims Nos.:
because they relate to parts of the international application that do not comply with the prescribed requirements to such an extent that no meaningful international search can be carried out, specifically:

3. Claims Nos.:
because they are dependent claims and are not drafted in accordance with the second and third sentences of Rule 6.4(a).

Box No. III Observations where unity of invention is lacking (Continuation of item 3 of first sheet)

This International Searching Authority found multiple inventions in this international application, as follows:
see extra sheet

1. As all required additional search fees were timely paid by the applicant, this international search report covers all searchable claims.
2. As all searchable claims could be searched without effort justifying additional fees, this Authority did not invite payment of additional fees.
3. As only some of the required additional search fees were timely paid by the applicant, this international search report covers only those claims for which fees were paid, specifically claims Nos.:
4. No required additional search fees were timely paid by the applicant. Consequently, this international search report is restricted to the invention first mentioned in the claims; it is covered by claims Nos.:
1-46

- Remark on Protest**
- The additional search fees were accompanied by the applicant's protest and, where applicable, the payment of a protest fee.
 - The additional search fees were accompanied by the applicant's protest but the applicable protest fee was not paid within the time limit specified in the invitation.
 - No protest accompanied the payment of additional search fees.

This application contains the following inventions or groups of inventions which are not so linked as to form a single general inventive concept under PCT Rule 13.1. In order for all inventions to be examined, the appropriate additional examination fees must be paid.

Group I, claims 1-46, drawn to an electro-acoustic system for wireless telemetry along a tubular body.

Group II, claims 47-52, drawn to a method for modulating acoustic waves using a multi-frequency shift keying (MFSK) process.

The inventions listed as Groups I-II do not relate to a single general inventive concept under PCT Rule 13.1 because, under PCT Rule 13.2, they lack the same or corresponding special technical features for the following reasons: the special technical feature of the Group I invention: electro-acoustic system for wireless telemetry along a tubular body, comprising: a tubular body fabricated from steel; at least one sensor disposed along the tubular body; a sensor communications node placed along the tubular body and connected to a wall of the tubular body, the sensor communications node being in electrical communication with the at least one sensor and configured to receive signals from the at least one sensor, the signals representing a parameter associated with a subsurface location along the tubular body; a topside communications node placed proximate a surface; a plurality of intermediate communications nodes spaced along the tubular body and attached to an outer wall of the tubular body, the intermediate communications nodes configured to transmit acoustic waves from the sensor communications node to the topside communications node in node-to-node arrangement; and a receiver at the surface configured to receive signals from the topside communications node; wherein each of the intermediate communications nodes comprises: a sealed housing; an independent power source residing within the housing; and an electro-acoustic transducer and associated transceiver also residing within the housing designed to receive and re-transmit the acoustic waves, thereby providing communications telemetry; and wherein the acoustic waves represent asynchronous packets of information comprising a plurality of separate tones, with at least some of the acoustic waves being indicative of the parameter as claimed therein is not present in the invention of Group II.

The special technical feature of the Group II invention: a method for modulating acoustic waves using a multi-frequency shift keying (MFSK) process, comprising: generating a first set of tones from a first electro-acoustic transceiver, each tone being associated with a defined frequency, and each tone being associated with a logical alphabet value; reviewing the first set of tones to determine if two consecutive tones have the same logical alphabet value; if two consecutive tones do have the same logical alphabet value, modifying the first set of tones to provide that no two same tones are sent consecutively, thereby generating a modified first set of tones; transmitting the modified first set of tones from the first electro-acoustic transceiver; receiving the modified first set of tones from the first electro-acoustic transceiver at a second electro-acoustic transceiver as a message packet; reviewing the modified first set of tones; and deconstructing the modified first set of tones back to its original first set of tones as claimed therein is not present in the invention of Groups I.

Groups I and II lack unity of invention because even though the inventions of these groups require the technical feature of an electro-acoustic transceiver transmitting acoustic waves, the waves comprising a plurality of different tones, this technical feature is not a special technical feature as it does not make a contribution over the prior art.

Specifically, EP 0636763 A2, MEYER et al, 01 February 1995 (01.02.1995) teaches an electro-acoustic transceiver transmitting acoustic waves (an acoustic transmitter/ receiver assembly (29) uphole of the drill string by the transmission and receipt of electric and acoustic signals through the drill string, abstract), the waves comprising a plurality of different tones (different frequencies at which the signals are plotted, col 9, lines 30- 41, see fig. 7).

Since none of the special technical features of the Group I or II inventions are found in more than one of the inventions, unity of invention is lacking.