



(86) Date de dépôt PCT/PCT Filing Date: 2003/11/25
 (87) Date publication PCT/PCT Publication Date: 2004/06/17
 (85) Entrée phase nationale/National Entry: 2005/05/06
 (86) N° demande PCT/PCT Application No.: US 2003/038158
 (87) N° publication PCT/PCT Publication No.: 2004/049981
 (30) Priorité/Priority: 2002/11/27 (10/305,652) US

(51) Cl.Int.⁷/Int.Cl.⁷ G06T 7/00, A61F 2/46, A61B 17/17, G06T 17/00

(71) Demandeur/Applicant:
CONFORMIS, INC., US

(72) Inventeurs/Inventors:
BEREZ, AARON, US;
FITZ, WOLFGANG, US;
LANG, PHILIPP, US;
STEINES, DANIEL, US;
TIMSARI, BIJAN, US;
TSOUGARAKIS, KONSTANTINOS, US;
VARGAS-VORACEK, RENE, US;
SNYDER, CECILY ANNE, US

(74) Agent: SMART & BIGGAR

(54) Titre : DISPOSITIFS D'ARTHROPLASTIE POUVANT ETRE SELECTIONNES EN FONCTION DU PATIENT ET INSTRUMENTS CHIRURGICAUX PERMETTANT DE REALISER UNE ARTHROPLASTIE TOTALE ET PARTIELLE DE MANIERE PLUS PRECISE, PLUS RAPIDE ET PLUS SIMPLE

(54) Title: PATIENT SELECTABLE JOINT ARTHROPLASTY DEVICES AND SURGICAL TOOLS FACILITATING INCREASED ACCURACY, SPEED AND SIMPLICITY IN PERFORMING TOTAL AND PARTIAL JOINT ARTHROPLASTY

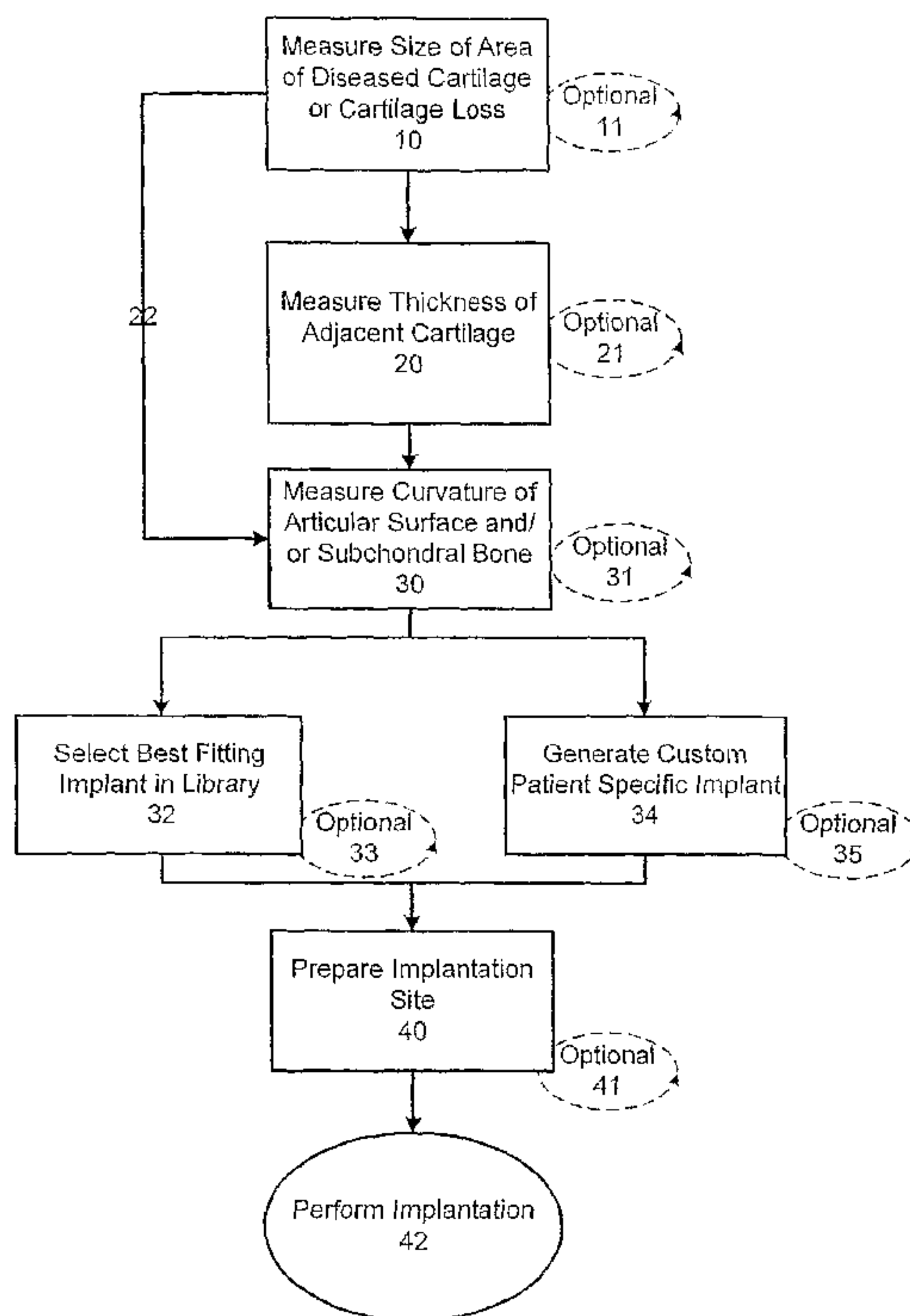

(57) Abrégé/Abstract:

Disclosed herein are methods, compositions and tools for repairing articular surfaces repair materials and for repairing an articular surface. The articular surface repairs are customizable or highly selectable by patient and geared toward providing optimal fit and function. The surgical tools are designed to be customizable or highly selectable by patient to increase the speed, accuracy and simplicity of performing total or partial arthroplasty.

(12) INTERNATIONAL APPLICATION PUBLISHED UNDER THE PATENT COOPERATION TREATY (PCT)

(19) World Intellectual Property
Organization
International Bureau



(43) International Publication Date
17 June 2004 (17.06.2004)

PCT

(10) International Publication Number
WO 2004/049981 A3

(51) International Patent Classification⁷: **G06T 7/00**,
17/00, A61F 2/46, A61B 17/17

(21) International Application Number:
PCT/US2003/038158

(22) International Filing Date:
25 November 2003 (25.11.2003)

(25) Filing Language: English

(26) Publication Language: English

(30) Priority Data:
10/305,652 27 November 2002 (27.11.2002) US

(71) Applicant (for all designated States except US): **CONFORMIS, INC.** [US/US]; 323 C Vintage, Park Drive, Foster City, CA 94404 (US).

(72) Inventors; and

(75) Inventors/Applicants (for US only): **BEREZ, Aaron** [US/US]; 1485 Laurel Street, Menlo Park, CA 94025 (US). **FITZ, Wolfgang** [DE/US]; 2 Joshua Path, Natick, MA 01760 (US). **LANG, Philipp** [DE/US]; 7 Fair Oaks

Terrace, Lexington, MA 02421 (US). **STEINES, Daniel** [DE/US]; 3619 Park Blvd., Palo Alto, CA 94306 (US). **TIMSARI, Bijan** [IR/US]; 9656 Carroll Canyon Road, Apt. F5, San Diego, CA 92126 (US). **TSOUGARAKIS, Konstantinos** [GR/US]; 950 High School Way, #3219, Mountain View, CA 94041 (US). **VARGAS-VORACEK, Rene** [BO/US]; 124 Piedra Drive, Sunnyvale, CA 94086 (US). **SNYDER, Cecily Anne** [US/US]; 69 Ovington Drive, East Falmouth, MA 02536 (US).

(74) Agents: **PASTERNAK, Dahna** et al.; Robins & Pasternak LLP, 1731 Embarcadero Road, Suite 230, Palo Alto, CA 94303 (US).

(81) Designated States (*national*): AE, AG, AL, AM, AT, AU, AZ, BA, BB, BG, BR, BW, BY, BZ, CA, CH, CN, CO, CR, CU, CZ, DE, DK, DM, DZ, EC, EE, EG, ES, FI, GB, GD, GE, GH, GM, HR, HU, ID, IL, IN, IS, JP, KE, KG, KP, KR, KZ, LC, LK, LR, LS, LT, LU, LV, MA, MD, MG, MK, MN, MW, MX, MZ, NI, NO, NZ, OM, PG, PH, PL, PT, RO, RU, SC, SD, SE, SG, SK, SL, SY, TJ, TM, TN, TR, TT, TZ, UA, UG, US, UZ, VC, VN, YU, ZA, ZM, ZW.

(84) Designated States (*regional*): ARIPO patent (BW, GH, GM, KE, LS, MW, MZ, SD, SL, SZ, TZ, UG, ZM, ZW), Eurasian patent (AM, AZ, BY, KG, KZ, MD, RU, TJ, TM),

[Continued on next page]

(54) Title: PATIENT SELECTABLE JOINT ARTHROPLASTY DEVICES AND SURGICAL TOOLS FACILITATING INCREASED ACCURACY, SPEED AND SIMPLICITY IN PERFORMING TOTAL AND PARTIAL JOINT ARTHROPLASTY

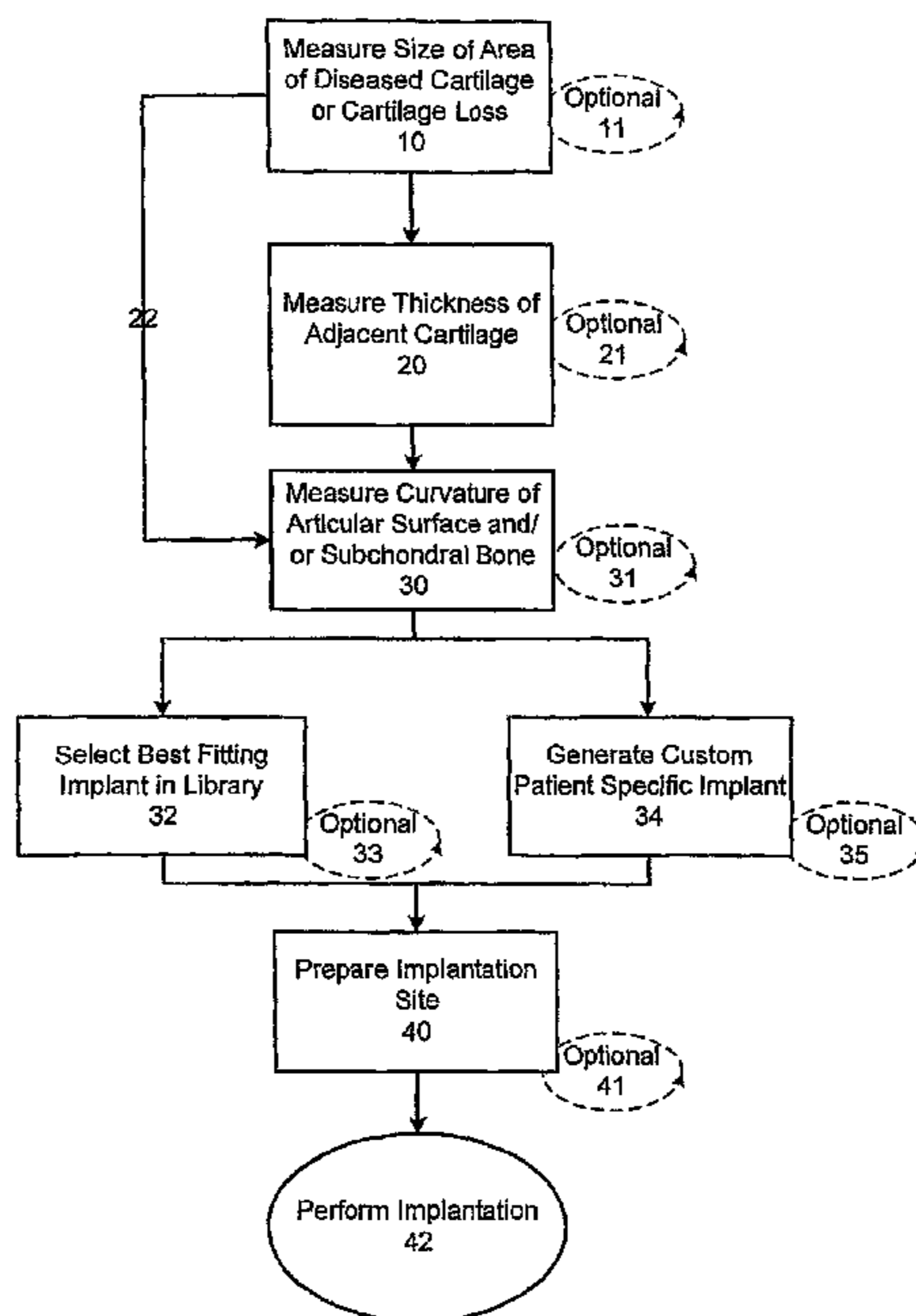

(57) Abstract: Disclosed herein are methods, compositions and tools for repairing articular surfaces repair materials and for repairing an articular surface. The articular surface repairs are customizable or highly selectable by patient and geared toward providing optimal fit and function. The surgical tools are designed to be customizable or highly selectable by patient to increase the speed, accuracy and simplicity of performing total or partial arthroplasty.

WO 2004/049981 A3

WO 2004/049981 A3

European patent (AT, BE, BG, CH, CY, CZ, DE, DK, EE, ES, FI, FR, GB, GR, HU, IE, IT, LU, MC, NL, PT, RO, SE, SI, SK, TR), OAPI patent (BF, BJ, CF, CG, CI, CM, GA, GN, GQ, GW, ML, MR, NE, SN, TD, TG).

Published:

- *with international search report*
- *before the expiration of the time limit for amending the claims and to be republished in the event of receipt of amendments*

(88) Date of publication of the international search report:
14 April 2005

For two-letter codes and other abbreviations, refer to the "Guidance Notes on Codes and Abbreviations" appearing at the beginning of each regular issue of the PCT Gazette.

*Patent Application For***PATIENT SELECTABLE JOINT ARTHROPLASTY DEVICES AND SURGICAL TOOLS
FACILITATING INCREASED ACCURACY, SPEED AND SIMPLICITY IN PERFORMING TOTAL
AND PARTIAL JOINT ARTHROPLASTY**

5

10

15

CROSS-REFERENCE TO RELATED APPLICATIONS

[0001] This application claims priority to U.S. Serial No. 10/305,652 entitled "METHODS AND COMPOSITIONS FOR ARTICULAR REPAIR," filed November 27, 2002.

[0002] This application is related to U.S. Serial No. 10/160,667, filed May 28, 2002, which in turn claims the benefit of U.S. Serial Number 60/293,488
20 entitled "METHODS TO IMPROVE CARTILAGE REPAIR SYSTEMS", filed May 25, 2001,
U.S. Serial Number 60/363,527, entitled "NOVEL DEVICES FOR CARTILAGE REPAIR,
filed March 12, 2002 and U.S. Serial Numbers 60/380,695 and 60/380,692,
entitled "METHODS AND COMPOSITIONS FOR CARTILAGE REPAIR," (Attorney Docket
Number 6750-0005p2) and "METHODS FOR JOINT REPAIR," (Attorney Docket
25 Number 6750-0005p3), filed May 14, 2002, all of which applications are hereby
incorporated by reference in their entireties.

FIELD OF THE INVENTION

[0003] The present invention relates to orthopedic methods, systems and
prosthetic devices and more particularly relates to methods, systems and devices
30 for articular resurfacing. The present invention also includes surgical molds

designed to achieve optimal cut planes in a joint in preparation for installation of a joint implant.

BACKGROUND OF THE INVENTION

5 [0004] There are various types of cartilage, *e.g.*, hyaline cartilage and fibrocartilage. Hyaline cartilage is found at the articular surfaces of bones, *e.g.*, in the joints, and is responsible for providing the smooth gliding motion characteristic of moveable joints. Articular cartilage is firmly attached to the underlying bones and measures typically less than 5mm in thickness in human joints, with considerable variation depending on joint and site within the joint. In addition, 10 articular cartilage is aneural, avascular, and alymphatic. In adult humans, this cartilage derives its nutrition by a double diffusion system through the synovial membrane and through the dense matrix of the cartilage to reach the chondrocyte, the cells that are found in the connective tissue of cartilage.

15 [0005] Adult cartilage has a limited ability of repair; thus, damage to cartilage produced by disease, such as rheumatoid and/or osteoarthritis, or trauma can lead to serious physical deformity and debilitation. Furthermore, as human articular cartilage ages, its tensile properties change. The superficial zone of the knee articular cartilage exhibits an increase in tensile strength up to the third decade of life, after which it decreases markedly with age as detectable 20 damage to type II collagen occurs at the articular surface. The deep zone cartilage also exhibits a progressive decrease in tensile strength with increasing age, although collagen content does not appear to decrease. These observations indicate that there are changes in mechanical and, hence, structural organization of cartilage with aging that, if sufficiently developed, can predispose cartilage to 25 traumatic damage.

[0006] For example, the superficial zone of the knee articular cartilage exhibits an increase in tensile strength up to the third decade of life, after which it decreases markedly with age as detectable damage to type II collagen occurs at

the articular surface. The deep zone cartilage also exhibits a progressive decrease in tensile strength with increasing age, although collagen content does not appear to decrease. These observations indicate that there are changes in mechanical and, hence, structural organization of cartilage with aging that, if

5 sufficiently developed, can predispose cartilage to traumatic damage.

[0007] Once damage occurs, joint repair can be addressed through a number of approaches. One approach includes the use of matrices, tissue scaffolds or other carriers implanted with cells (*e.g.*, chondrocytes, chondrocyte progenitors, stromal cells, mesenchymal stem cells, etc.). These solutions have

10 been described as a potential treatment for cartilage and meniscal repair or replacement. See, also, International Publications WO 99/51719 to Fofonoff, published October 14, 1999; WO01/91672 to Simon et al., published 12/6/2001; and WO01/17463 to Mannsmann, published March 15, 2001; U.S. Patent No. 6,283,980 B1 to Vibe-Hansen et al., issued September 4, 2001, U.S. Patent No.

15 5,842,477 to Naughton issued December 1, 1998, U.S. Patent No. 5,769,899 to Schwartz et al. issued June 23, 1998, U.S. Patent No. 4,609,551 to Caplan et al. issued September 2, 1986, U.S. Patent No. 5,041,138 to Vacanti et al. issued August 29, 1991, U.S. Patent No. 5,197,985 to Caplan et al. issued March 30, 1993, U.S. Patent No. 5,226,914 to Caplan et al. issued July 13, 1993, U.S.

20 Patent No. 6,328,765 to Hardwick et al. issued December 11, 2001, U.S. Patent No. 6,281,195 to Rueger et al. issued August 28, 2001, and U.S. Patent No. 4,846,835 to Grande issued July 11, 1989. However, clinical outcomes with biologic replacement materials such as allograft and autograft systems and tissue scaffolds have been uncertain since most of these materials cannot achieve a

25 morphologic arrangement or structure similar to or identical to that of normal, disease-free human tissue it is intended to replace. Moreover, the mechanical durability of these biologic replacement materials remains uncertain.

[0008] Usually, severe damage or loss of cartilage is treated by replacement of the joint with a prosthetic material, for example, silicone, *e.g.* for

cosmetic repairs, or metal alloys. See, e.g., U.S. Patent No. 6,383,228 to Schmotzer, issued May 7, 2002; U.S. Patent No. 6,203,576 to Afriat et al., issued March 20, 2001; U.S. Patent No. 6,126,690 to Ateshian, et al., issued October 3, 2000. Implantation of these prosthetic devices is usually associated with loss of
5 underlying tissue and bone without recovery of the full function allowed by the original cartilage and, with some devices, serious long-term complications associated with the loss of significant amount of tissue and bone can include infection, osteolysis and also loosening of the implant.

[0009] Further, joint arthroplasties are highly invasive and require surgical
10 resection of the entire or the majority of the articular surface of one or more bones. With these procedures, the marrow space is reamed in order to fit the stem of the prosthesis. The reaming results in a loss of the patient's bone stock. U.S. Patent 5,593,450 to Scott et al. issued January 14, 1997 discloses an oval domed shaped patella prosthesis. The prosthesis has a femoral component that includes
15 two condyles as articulating surfaces. The two condyles meet to form a second trochlear groove and ride on a tibial component that articulates with respect to the femoral component. A patella component is provided to engage the trochlear groove. U.S. Patent 6,090,144 to Letot et al. issued July 18, 2000 discloses a knee prosthesis that includes a tibial component and a meniscal component that
20 is adapted to be engaged with the tibial component through an asymmetrical engagement.

[0010] Another joint subject to invasive joint procedures is the hip. U.S. Patent 6,262,948 to Storer et al. issued September 30, 2003 discloses a femoral hip prosthesis that replaces the natural femoral head. U.S. Patent Publications
25 2002/0143402 A1 and 2003/0120347 to Steinberg published October 3, 2002 and June 26, 2003, respectively, also disclose a hip prosthesis that replaces the femoral head and provides a member for communicating with the ball portion of the socket within the hip joint.

[0011] A variety of materials can be used in replacing a joint with a prosthetic, for example, silicone, *e.g.* for cosmetic repairs, or suitable metal alloys are appropriate. See, *e.g.*, U.S. Patent No. 6,443,991 B1 to Running issued September 3, 2002, U.S. Patent No. 6,387,131 B1 to Miehlike et al. issued May 14, 2002; U.S. Patent No. 6,383,228 to Schmotzer issued May 7, 2002; U.S. Patent No. 6,344,059 B1 to Krakovits et al. issued February 5, 1002; U.S. Patent No. 6,203,576 to Afriat et al. issued March 20, 2001; U.S. Patent No. 6,126,690 to Ateshian et al. issued October 3, 2000; U.S. Patent 6,013,103 to Kaufman et al. issued January 11, 2000. Implantation of these prosthetic devices is usually associated with loss of underlying tissue and bone without recovery of the full function allowed by the original cartilage and, with some devices, serious long-term complications associated with the loss of significant amounts of tissue and bone can cause loosening of the implant. One such complication is osteolysis. Once the prosthesis becomes loosened from the joint, regardless of the cause, the prosthesis will then need to be replaced. Since the patient's bone stock is limited, the number of possible replacement surgeries is also limited for joint arthroplasty.

[0012] As can be appreciated, joint arthroplasties are highly invasive and require surgical resection of the entire, or a majority of the, articular surface of one or more bones involved in the repair. Typically with these procedures, the marrow space is fairly extensively reamed in order to fit the stem of the prosthesis within the bone. Reaming results in a loss of the patient's bone stock and over time subsequent osteolysis will frequently lead to loosening of the prosthesis. Further, the area where the implant and the bone mate degrades over time requiring the prosthesis to eventually be replaced. Since the patient's bone stock is limited, the number of possible replacement surgeries is also limited for joint arthroplasty. In short, over the course of 15 to 20 years, and in some cases even shorter time periods, the patient can run out of therapeutic options ultimately resulting in a painful, non-functional joint.

[0013] A variety of tools are available to assist surgeons in performing joint surgery. In the knee, for example, U.S. Patent 4,501,266 to McDaniel issued February 26, 1985 discloses a knee distraction device that facilitates knee arthroplasty. The device has an adjustable force calibration mechanism that
5 enables the device to accommodate controlled selection of the ligament-tensioning force to be applied to the respective, opposing sides of the knee. U.S. Patent 5,002,547 to Poggie et al. issued March 26, 1991 discloses a modular apparatus for use in preparing the bone surface for implantation of a modular total knee prosthesis. The apparatus has cutting guides, templates, alignment devices
10 along with a distractor and clamping instruments that provide modularity and facilitate bone resection and prosthesis implantation. U.S. Patent 5,250,050 to Poggie et al. issued October 5, 1993 is also directed to a modular apparatus for use in preparing a bone surface for the implantation of a modular total knee prosthesis. U.S. Patent 5,387,216 to Thornhill et al. issued February 7, 1995
15 discloses instrumentation for use in knee revision surgery. A bearing sleeve is provided that is inserted into the damaged canal in order to take up additional volume. The rod passes through the sleeve and is positioned to meet the natural canal of the bone. The rod is then held in a fixed position by the bearing sleeve. A cutting guide can then be mounted on the rod for cutting the bone and to provide a
20 mounting surface for the implant. U.S. Patent 6,056,756 to Eng et al. issued May 2, 2000 discloses a tool for preparing the distal femoral end for a prosthetic implant. The tool lays out the resection for prosthetic replacement and includes a jack for pivotally supporting an opposing bone such that the jack raises the opposing bone in flexion to the spacing of the intended prosthesis. U.S. Patent
25 6,106,529 to Techiera issued August 22, 2000 discloses an epicondylar axis referencing drill guide for use in resection to prepare a bone end for prosthetic joint replacement. U.S. Patent 6,296,646 to Williamson issued October 2, 2001 discloses a system that allows a practitioner to position the leg in the alignment that is directed at the end of the implant procedure and to cut both the femur and

tibia while the leg is fixed in alignment. U.S. Patent 6,620,168 to Lombardi et al. issued September 16, 2003 discloses a tool for intermedullary revision surgery along with tibial components.

5 **[0014]** U.S. Patent 5,578,037 to Sanders et al. issued November 26, 1996 discloses a surgical guide for femoral resection. The guide enables a surgeon to resect a femoral neck during a hip arthroplasty procedure so that the femoral prosthesis can be implanted to preserve or closely approximate the anatomic center of rotation of the hip.

10 **[0015]** U.S. Patent No. 6,206,927 to Fell, et al., issued March 27, 2001, and U.S. Patent No. 6,558,421 to Fell, et al., issued May 6, 2003, disclose a surgically implantable knee prosthesis that does not require bone resection. This prosthesis is described as substantially elliptical in shape with one or more straight edges. Accordingly, these devices are not designed to substantially conform to the actual shape (contour) of the remaining cartilage in vivo and/or the underlying bone.
15 Thus, integration of the implant can be extremely difficult due to differences in thickness and curvature between the patient's surrounding cartilage and/or the underlying subchondral bone and the prosthesis.

[0016] Interpositional knee devices that are not attached to both the tibia and femur have been described. For example, Platt et al. (1969) "Mould
20 Arthroplasty of the Knee," Journal of Bone and Joint Surgery 51B(1):76-87, describes a hemi-arthroplasty with a convex undersurface that was not rigidly attached to the tibia. Devices that are attached to the bone have also been described. Two attachment designs are commonly used. The McKeever design is a cross-bar member, shaped like a "t" from a top perspective view, that extends
25 from the bone mating surface of the device such that the "t" portion penetrates the bone surface while the surrounding surface from which the "t" extends abuts the bone surface. See McKeever, "Tibial Plateau Prosthesis," Chapter 7, p. 86. An alternative attachment design is the MacIntosh design, which replaces the "t" shaped fin for a series of multiple flat serrations or teeth. See Potter, "Arthroplasty

of the Knee with Tibial Metallic Implants of the McKeever and MacIntosh Design," *Surg. Clins. Of North Am.* **49(4)**: 903-915 (1969).

[0017] U.S. Patent 4,502,161 to Wall issued March 5, 1985, describes a
5 prosthetic meniscus constructed from materials such as silicone rubber or Teflon
with reinforcing materials of stainless steel or nylon strands. U.S.
Patent 4,085,466 to Goodfellow et al. issued March 25, 1978, describes a
meniscal component made from plastic materials. Reconstruction of meniscal
lesions has also been attempted with carbon-fiber-polyurethane-poly (L-lactide).
Leeslag, et al., *Biological and Biomechanical Performance of Biomaterials*
10 (Christel et al., eds.) Elsevier Science Publishers B.V., Amsterdam. 1986. pp. 347-
352. Reconstruction of meniscal lesions is also possible with bioresorbable
materials and tissue scaffolds.

[0018] However, currently available devices do not always provide ideal
alignment with the articular surfaces and the resultant joint congruity. Poor
15 alignment and poor joint congruity can, for example, lead to instability of the joint.
In the knee joint, instability typically manifests as a lateral instability of the joint.

[0019] Thus, there remains a need for compositions for joint repair,
including methods and compositions that facilitate the integration between the
cartilage replacement system and the surrounding cartilage. There is also a need
20 for tools that increase the accuracy of cuts made to the bone in a joint in
preparation for surgical implantation of, for example, an artificial joint.

SUMMARY OF THE INVENTION

[0020] The present invention provides novel devices and methods for
replacing a portion (*e.g.*, diseased area and/or area slightly larger than the
25 diseased area) of a joint (*e.g.*, cartilage and/or bone) with a non-pliable, non-liquid
(*e.g.*, hard) implant material, where the implant achieves a near anatomic fit with
the surrounding structures and tissues. In cases where the devices and/or
methods include an element associated with the underlying articular bone, the

invention also provides that the bone-associated element achieves a near anatomic alignment with the subchondral bone. The invention also provides for the preparation of an implantation site with a single cut, or a few relatively small cuts.

5 **[0021]** In one aspect, the invention includes a method for providing articular replacement material, the method comprising the step of producing articular replacement (*e.g.*, cartilage replacement material) of selected dimensions (*e.g.*, size, thickness and/or curvature).

10 **[0022]** In another aspect, the invention includes a method of making cartilage repair material, the method comprising the steps of (a) measuring the dimensions (*e.g.*, thickness, curvature and/or size) of the intended implantation site or the dimensions of the area surrounding the intended implantation site; and (b) providing cartilage replacement material that conforms to the measurements obtained in step (a). In certain aspects, step (a) comprises measuring the
15 thickness of the cartilage surrounding the intended implantation site and measuring the curvature of the cartilage surrounding the intended implantation site. In other embodiments, step (a) comprises measuring the size of the intended implantation site and measuring the curvature of the cartilage surrounding the intended implantation site. In other embodiments, step (a) comprises measuring
20 the thickness of the cartilage surrounding the intended implantation site, measuring the size of the intended implantation site, and measuring the curvature of the cartilage surrounding the intended implantation site. In other embodiments, step (a) comprises reconstructing the shape of healthy cartilage surface at the intended implantation site.

25 **[0023]** In any of the methods described herein, one or more components of the articular replacement material (*e.g.*, the cartilage replacement material) can be non-pliable, non-liquid, solid or hard. The dimensions of the replacement material can be selected following intraoperative measurements. Measurements can also be made using imaging techniques such as ultrasound, MRI, CT scan, x-ray

imaging obtained with x-ray dye and fluoroscopic imaging. A mechanical probe (with or without imaging capabilities) can also be used to select dimensions, for example an ultrasound probe, a laser, an optical probe and a deformable material or device.

5 **[0024]** In any of the methods described herein, the replacement material can be selected (for example, from a pre-existing library of repair systems), grown from cells and/or hardened from various materials. Thus, the material can be produced pre- or post-operatively. Furthermore, in any of the methods described herein the repair material can also be shaped (*e.g.*, manually, automatically or by
10 machine), for example using mechanical abrasion, laser ablation, radiofrequency ablation, cryoablation and/or enzymatic digestion.

15 **[0025]** In any of the methods described herein, the articular replacement material can comprise synthetic materials (*e.g.*, metals, liquid metals, polymers, alloys or combinations thereof) or biological materials such as stem cells, fetal cells or chondrocyte cells.

20 **[0026]** In another aspect, the invention includes a method of repairing a cartilage in a subject, the method comprising the step of implanting cartilage repair material prepared according to any of the methods described herein.

25 **[0027]** In yet another aspect, the invention provides a method of determining the curvature of an articular surface, the method comprising the step of intraoperatively measuring the curvature of the articular surface using a mechanical probe. The articular surface can comprise cartilage and/or subchondral bone. The mechanical probe (with or without imaging capabilities) can include, for example an ultrasound probe, a laser, an optical probe and/or a deformable material.

30 **[0028]** In a still further aspect, the invention provides a method of producing an articular replacement material comprising the step of providing an articular

replacement material that conforms to the measurements obtained by any of the methods of described herein.

[0029] In a still further aspect, the invention includes a partial or full articular prosthesis comprising a first component comprising a cartilage replacement material; and an optional second component comprising one or more metals, wherein said second component can have a curvature similar to subchondral bone, wherein said prosthesis comprises less than about 80% of the articular surface. In certain embodiments, the first and/or second component comprises a non-pliable material (*e.g.*, a metal, a polymer, a metal alloy, a solid biological material). Other materials that can be included in the first and/or second components include polymers, biological materials, metals, metal alloys or combinations thereof. Furthermore, one or both components can be smooth or porous (or porous coated) using any methods or mechanisms to achieve in-growth of bone known in the art. In certain embodiments, the first component exhibits biomechanical properties (*e.g.*, elasticity, resistance to axial loading or shear forces) similar to articular cartilage. The first and/or second component can be bioresorbable and, in addition, the first or second components can be adapted to receive injections.

[0030] In another aspect, an articular prosthesis comprising an external surface located in the load bearing area of an articular surface, wherein the dimensions of said external surface achieve a near anatomic fit with the adjacent, underlying or opposing cartilage is provided. The prosthesis can comprise one or more metals or metal alloys.

[0031] In yet another aspect, an articular repair system comprising (a) cartilage replacement material, wherein said cartilage replacement material has a curvature similar to surrounding, adjacent, underlying or opposing cartilage; and (b) at least one non-biologic material, wherein said articular surface repair system comprises a portion of the articular surface equal to, smaller than, or greater than, the weight-bearing surface that is provided. In certain embodiments, the cartilage

replacement material is non-pliable (*e.g.*, hard hydroxyapatite, etc.). In certain embodiments, the system exhibits biomechanical (*e.g.*, elasticity, resistance to axial loading or shear forces) and/or biochemical properties similar to articular cartilage. The first and/or second component can be bioresorbable and, in addition, the first or second components can be adapted to receive injections.

5
[0032] In a still further aspect of the invention, an articular surface repair system comprising a first component comprising a cartilage replacement material, wherein said first component has dimensions similar to that of adjacent, surrounding, underlying or opposing cartilage; and a second component, wherein
10 said second component has a curvature similar to subchondral bone, wherein said articular surface repair system comprises less than about 80% of the articular surface (*e.g.*, a single femoral condyle, tibia, etc.) is provided. In certain embodiments, the first component is non-pliable (*e.g.*, hard hydroxyapatite, etc.). In certain embodiments, the system exhibits biomechanical (*e.g.*, elasticity,
15 resistance to axial loading or shear forces) and/or biochemical properties similar to articular cartilage. The first and/or second component can be bioresorbable and, in addition, the first or second components can be adapted to receive injections. In certain embodiments, the first component has a curvature and thickness similar to that of adjacent, underlying, opposing or surrounding cartilage.
20 The thickness and/or curvature can vary across the implant material.

[0033] In a still further embodiment, a partial articular prosthesis comprising (a) a metal or metal alloy; and (b) an external surface located in the load bearing area of an articular surface, wherein the external surface designed to achieve a near anatomic fit with the adjacent surrounding, underlying or opposing cartilage
25 is provided.

[0034] Any of the repair systems or prostheses described herein (*e.g.*, the external surface) can comprise a polymeric material, for example attached to said metal or metal alloy. Any of the repair systems can be entirely composed of polymer. Further, any of the systems or prostheses described herein can be

adapted to receive injections, for example, through an opening in the external surface of said cartilage replacement material (e.g., an opening in the external surface terminates in a plurality of openings on the bone surface). Bone cement, polymers, Liquid Metal, therapeutics, and/or other bioactive substances can be
5 injected through the opening(s). In certain embodiments, bone cement is injected under pressure in order to achieve permeation of portions of the marrow space with bone cement. In addition, any of the repair systems or prostheses described herein can be anchored in bone marrow or in the subchondral bone itself. One or more anchoring extensions (e.g., pegs, pins, etc.) can extend through the bone
10 and/or bone marrow.

[0035] In any of the embodiments and aspects described herein, the joint can be a knee, shoulder, hip, vertebrae, elbow, ankle, wrist etc.

[0036] In another aspect, a method of designing an articular implant comprising the steps of obtaining an image of a joint, wherein the image includes
15 both normal cartilage and diseased cartilage; reconstructing dimensions of the diseased cartilage surface to correspond to normal cartilage; and designing the articular implant to match the dimensions of the reconstructed diseased cartilage surface or to match an area slightly greater than the diseased cartilage surface is provided. The image can be, for example, an intraoperative image including a
20 surface detection method using any techniques known in the art, e.g., mechanical, optical ultrasound, and known devices such as MRI, CT, ultrasound, digital tomosynthesis and/or optical coherence tomography images. In certain embodiments, reconstruction is performed by obtaining a surface that follows the contour of the normal cartilage. The surface can be parametric and include
25 control points that extend the contour of the normal cartilage to the diseased cartilage and/or a B-spline surface. In other embodiments, the reconstruction is performed by obtaining a binary image of cartilage by extracting cartilage from the image, wherein diseased cartilage appears as indentations in the binary image; and performing, for example, a morphological closing operation (e.g., performed in

two or three dimensions using a structuring element and/or a dilation operation followed by an erosion operation) to determine the shape of an implant to fill the areas of diseased cartilage.

[0037] In yet another aspect, described herein are systems for evaluating the fit of an articular repair system into a joint, the systems comprising one or more computing means capable of superimposing a three-dimensional (*e.g.*, three-dimensional representations of at least one articular structure and of the articular repair system) or a two-dimensional cross-sectional image (*e.g.*, cross-sectional images reconstructed in multiple planes) of a joint and an image of an articular repair system to determine the fit of the articular repair system. The computing means can be: capable of merging the images of the joint and the articular repair system into a common coordinate system; capable of selecting an articular repair system having the best fit; capable of rotating or moving the images with respect to each other; and/or capable of highlighting areas of poor alignment between the articular repair system and the surrounding articular surfaces. The three-dimensional representations can be generated using a parametric surface representation.

[0038] In yet another aspect, surgical tools for preparing a joint to receive an implant are described, for example a tool comprising one or more surfaces or members that conform at least partially to the shape of the articular surfaces of the joint (*e.g.*, a femoral condyle and/or tibial plateau of a knee joint). In certain embodiments, the tool comprises Lucite silastic and/or other polymers or suitable materials. The tool can be re-useable or single-use. The tool can be comprised of a single component or multiple components. In certain embodiments, the tool comprises an array of adjustable, closely spaced pins. In any embodiments described herein, the surgical tool can be designed to further comprise an aperture therein, for example one or more apertures having dimensions (*e.g.*, diameter, depth, etc.) smaller or equal to one or more dimensions of the implant and/or one or more apertures adapted to receive one or more injectables. Any of

the tools described herein can further include one or more curable (hardening) materials or compositions, for example that are injected through one or more apertures in the tool and which solidify to form an impression of the articular surface.

5 **[0039]** In still another aspect, a method of evaluating the fit of an articular repair system into a joint is described herein, the method comprising obtaining one or more three-dimensional images (*e.g.*, three-dimensional representations of at least one articular structure and of the articular repair system) or two-dimensional cross-sectional images (*e.g.*, cross-sectional images reconstructed in
10 multiple planes) of a joint, wherein the joint includes at least one defect or diseased area; obtaining one or more images of one or more articular repair systems designed to repair the defect or diseased area; and evaluating the images to determine the articular repair system that best fits the defect (*e.g.*, by superimposing the images to determine the fit of the articular repair system into
15 the joint). In certain embodiments, the images of the joint and the articular repair system are merged into a common coordinate system. The three-dimensional representations can be generated using a parametric surface representation. In any of these methods, the evaluation can be performed by manual visual inspection and/or by computer (*e.g.*, automated). The images can be obtained,
20 for example, using a C-arm system and/or radiographic contrast.

[0040] In yet another aspect, described herein is a method of placing an implant into an articular surface having a defect or diseased area, the method comprising the step of imaging the joint using a C-arm system during placement of the implant, thereby accurately placing the implant into a defect or diseased area.

25 **[0041]** Also disclosed is a customizable, or patient specific, implant configured for placement between joint surfaces formed by inserting a hollow device having an aperture and a lumen into a target joint, and injecting material into the hollow device to form an implant.

[0042] A customizable, or patient specific, implant configured for placement between joint surfaces is also disclosed wherein the implant is formed by inserting a retaining device that engages at least a portion of one joint surface in a joint and injecting material into an aperture of the retaining device to form an
5 implant.

[0043] The invention is also directed to tools. A is disclosed that tool comprises: a mold having a surface for engaging a joint surface; a block that communicates with the mold; and at least one guide aperture in the block. Another tool is disclosed that is formed at least partially in situ and comprises: a
10 mold formed in situ using at least one of an inflatable hollow device or a retaining device to conform to the joint surface on at least one surface having a surface for engaging a joint surface; a block that communicates with the mold; and at least one guide aperture in the block.

[0044] A method of placing an implant into a joint is also provided. The
15 method comprises the steps of imaging the joint using a C-arm system, obtaining a cross-sectional image with the C-arm system, and utilizing the image for placing the implant into a joint.

BRIEF DESCRIPTION OF THE DRAWINGS

[0045] The file of this patent contains at least one drawing executed in
20 color. Copies of this patent with color drawing(s) will be provided by the Patent and Trademark Office upon request and payment of the necessary fee.

[0046] **FIG. 1** is a flowchart depicting various methods of the present invention including, measuring the size of an area of diseased cartilage or cartilage loss, measuring the thickness of the adjacent cartilage, and measuring
25 the curvature of the articular surface and/or subchondral bone. Based on this information, a best-fitting implant can be selected from a library of implants or a

patient specific custom implant can be generated. The implantation site is subsequently prepared and the implantation is performed.

5 [0047] FIG. 2 is a color reproduction of a three-dimensional thickness map of the articular cartilage of the distal femur. Three-dimensional thickness maps can be generated, for example, from ultrasound, CT or MRI data. Dark holes within the substances of the cartilage indicate areas of full thickness cartilage loss.

[0048] FIG. 3A shows an example of a Placido disc of concentrically arranged circles of light. FIG. 3B shows an example of a projected Placido disc on a surface of fixed curvature.

10 [0049] FIG. 4 shows a reflection resulting from a projection of concentric circles of light (Placido Disk) on each femoral condyle, demonstrating the effect of variation in surface contour on the reflected circles.

[0050] FIG. 5 shows an example of a 2D color-coded topographical map of an irregularly curved surface.

15 [0051] FIG. 6 shows an example of a 3D color-coded topographical map of an irregularly curved surface.

[0052] FIGS. 7A-H illustrate, in cross-section, various stages of knee resurfacing. FIG. 7A shows an example of normal thickness cartilage and a cartilage defect. FIG. 7B shows an imaging technique or a mechanical, optical, laser or ultrasound device measuring the thickness and detecting a sudden change in thickness indicating the margins of a cartilage defect. FIG. 7C shows a weight-bearing surface mapped onto the articular cartilage. FIG. 7D shows an intended implantation site and cartilage defect. FIG. 7E depicts placement of an exemplary single component articular surface repair system. FIG. 7F shows an exemplary multi-component articular surface repair system. FIG. 7G shows an exemplary single component articular surface repair system. FIG. 7H shows an exemplary multi-component articular surface repair system.

20

25

[0053] FIGS. 8A-E, illustrate, in cross-section, exemplary knee imaging and resurfacing. FIG. 8A shows a magnified view of an area of diseased cartilage. FIG. 8B shows a measurement of cartilage thickness adjacent to the defect. FIG. 8C depicts placement of a multi-component mini-prosthesis for articular resurfacing. FIG. 8D is a schematic depicting placement of a single component mini-prosthesis utilizing stems or pegs. FIG. 8E depicts placement of a single component mini-prosthesis utilizing stems and an opening for injection of bone cement.

[0054] FIGS. 9A-C, illustrate, in cross-section, other exemplary knee resurfacing devices and methods. FIG. 9A depicts normal thickness cartilage in the anterior and central and posterior portion of a femoral condyle and a large area of diseased cartilage in the posterior portion of the femoral condyle. FIG. 9B depicts placement of a single component articular surface repair system. FIG. 9C depicts a multi-component articular surface repair system.

[0055] FIGS. 10A-B are flow charts illustrating steps for forming a device in situ.

[0056] FIGS. 11A-G illustrate, in cross-section, the use of an inflation device to form an implant. FIG. 11A illustrates a single lumen balloon inserted between two joint surfaces where the inflation occurs within the bounds of the joint. FIG. 11B illustrates another single lumen balloon inserted between two joint surfaces where the inflatable surfaces extend beyond a first and second edge of a joint. FIG. 11C illustrates another single lumen balloon between two joint surfaces. FIG. 11D illustrates a multi-balloon solution using two balloons where the balloons are adjacent to each other within the joint. FIG. 11E illustrates an alternative multi-balloon solution wherein a first balloon is comprised within a second balloon. FIG. 11F illustrates another multi-balloon solution where a first balloon lies within the lumen of a second balloon and further wherein the second balloon is adjacent a third balloon. FIG. 11G illustrates a 3 balloon configuration wherein a first balloon

lies adjacent a second balloon and a third balloon fits within the lumen of one of the first or second balloon.

[0057] FIGS. 12A-E illustrate a variety of cross-sectional shapes achieved using balloons with variable wall thicknesses or material compositions. In FIG. 12A
5 the inflation device enables the implant to achieve a surface conforming to the irregularities of the joint surface. In FIG. 12B the inflation device enables the implant to achieve a surface that sits above the irregular joint surface; FIG. 12c illustrates a device formed where a central portion of the device sits above the joint surface irregularities while the proximal and distal ends illustrated form a
10 lateral abutting surface to the joint defects. FIG. 12D illustrates a device formed using a first inflation device within a second inflation device, with an exterior configuration similar to that shown in FIG. 12A; while FIG. 12E illustrates an alternative device formed using at least two different inflation devices having an exterior shape similar to the device shown in FIG. 12c.

15 **[0058]** FIGS. 13A-J(1-3) show a variety of cross-sectional views of the inflation devices shown in FIGS. 11 and 12 taken at a position perpendicular to the views shown in FIGS. 11 and 12.

[0059] FIGS. 14A-J illustrate the use of a retaining device to form an implant *in situ*.

20 **[0060]** FIGS. 15A-B show single and multiple component devices. FIG. 15A shows an exemplary single component articular surface repair system with varying curvature and radii. FIG. 15B depicts a multi-component articular surface repair system with a second component that mirrors the shape of the subchondral bone and a first component closely matches the shape and curvature of the
25 surrounding normal cartilage.

[0061] FIGS. 16A-B show exemplary articular repair systems having an outer contour matching the surrounding normal cartilage. The systems are implanted into the underlying bone using one or more pegs.

[0062] FIG. 17 shows a perspective view of an exemplary articular repair device including a flat surface to control depth and prevent toggle; an exterior surface having the contour of normal cartilage; flanges to prevent rotation and control toggle; a groove to facilitate tissue in-growth.

5 **[0063]** FIGS. 18A-D depict, in cross-section, another example of an implant with multiple anchoring pegs. FIG. 18B-D show various cross-sectional representations of the pegs: FIG. 18B shows a peg having a groove; FIG. 18C shows a peg with radially-extending arms that help anchor the device in the underlying bone; and FIG. 18D shows a peg with multiple grooves or flanges.

10 **[0064]** FIG. 19A-B depict an overhead view of an exemplary implant with multiple anchoring pegs and depict how the pegs are not necessarily linearly aligned along the longitudinal axis of the device.

[0065] FIGS. 20A-E depict an exemplary implant having radially extending arms. FIGS. 20B-E are overhead views of the implant showing that the shape of the peg need not be conical.

15

[0066] FIG. 21A illustrates a femur, tibia and fibula along with the mechanical and anatomic axes. FIGS. 21B-E illustrate the tibia with the anatomic and mechanical axis used to create a cutting plane along with a cut femur and tibia. FIG. 21F illustrates the proximal end of the femur including the head of the femur.

20

[0067] FIG. 22 shows an example of a surgical tool having one surface matching the geometry of an articular surface of the joint. Also shown is an aperture in the tool capable of controlling drill depth and width of the hole and allowing implantation of an insertion of implant having a press-fit design.

25 **[0068]** FIG. 23 is a flow chart depicting various methods of the invention used to create a mold for preparing a patient's joint for arthroscopic surgery.

[0069] FIG. 24A depicts, in cross-section, an example of a surgical tool containing an aperture through which a surgical drill or saw can fit. The aperture guides the drill or saw to make the proper hole or cut in the underlying bone. Dotted lines represent where the cut corresponding to the aperture will be made in bone. FIG. 24B depicts, in cross-section, an example of a surgical tool containing apertures through which a surgical drill or saw can fit and which guide the drill or saw to make cuts or holes in the bone. Dotted lines represent where the cuts corresponding to the apertures will be made in bone.

[0070] FIGS. 25A-Q illustrate tibial cutting blocks and molds used to create a surface perpendicular to the anatomic axis for receiving the tibial portion of a knee implant.

[0071] FIGS. 26A-O illustrate femur cutting blocks and molds used to create a surface for receiving the femoral portion of a knee implant.

[0072] FIG. 27A-G illustrate patellar cutting blocks and molds used to prepare the patella for receiving a portion of a knee implant.

[0073] FIG. 28A-H illustrate femoral head cutting blocks and molds used to create a surface for receiving the femoral portion of a knee implant.

[0074] FIG. 29A-D illustrate acetabulum cutting blocks and molds used to create a surface for a hip implant.

DETAILED DESCRIPTION OF THE INVENTION

[0075] The following description is presented to enable any person skilled in the art to make and use the invention. Various modifications to the embodiments described will be readily apparent to those skilled in the art, and the generic principles defined herein can be applied to other embodiments and applications without departing from the spirit and scope of the present invention as defined by the appended claims. Thus, the present invention is not intended to be limited to the embodiments shown, but is to be accorded the widest scope

consistent with the principles and features disclosed herein. To the extent necessary to achieve a complete understanding of the invention disclosed, the specification and drawings of all issued patents, patent publications, and patent applications cited in this application are incorporated herein by reference.

5 **[0076]** As will be appreciated by those of skill in the art, the practice of the present invention employs, unless otherwise indicated, conventional methods of x-ray imaging and processing, x-ray tomosynthesis, ultrasound including A-scan, B-scan and C-scan, computed tomography (CT scan), magnetic resonance imaging (MRI), optical coherence tomography, single photon emission tomography
10 (SPECT) and positron emission tomography (PET) within the skill of the art. Such techniques are explained fully in the literature and need not be described herein. See, *e.g.*, X-Ray Structure Determination: A Practical Guide, 2nd Edition, editors Stout and Jensen, 1989, John Wiley & Sons, publisher; Body CT: A Practical Approach, editor Slone, 1999, McGraw-Hill publisher; X-ray Diagnosis: A
15 Physician's Approach, editor Lam, 1998 Springer-Verlag, publisher; and Dental Radiology: Understanding the X-Ray Image, editor Laetitia Brocklebank 1997, Oxford University Press publisher. See *also*, The Essential Physics of Medical Imaging (2nd Ed.), Jerrold T. Bushberg, et al.

20 **[0077]** The present invention provides methods and compositions for repairing joints, particularly for repairing articular cartilage and for facilitating the integration of a wide variety of cartilage repair materials into a subject. Among other things, the techniques described herein allow for the customization of cartilage repair material to suit a particular subject, for example in terms of size, cartilage thickness and/or curvature. When the shape (*e.g.*, size, thickness and/or
25 curvature) of the articular cartilage surface is an exact or near anatomic fit with the non-damaged cartilage or with the subject's original cartilage, the success of repair is enhanced. The repair material can be shaped prior to implantation and such shaping can be based, for example, on electronic images that provide information regarding curvature or thickness of any "normal" cartilage surrounding

the defect and/or on curvature of the bone underlying the defect. Thus, the current invention provides, among other things, for minimally invasive methods for partial joint replacement. The methods will require only minimal or, in some instances, no loss in bone stock. Additionally, unlike with current techniques, the methods described herein will help to restore the integrity of the articular surface by achieving an exact or near anatomic match between the implant and the surrounding or adjacent cartilage and/or subchondral bone.

[0078] Advantages of the present invention can include, but are not limited to, (i) customization of joint repair, thereby enhancing the efficacy and comfort level for the patient following the repair procedure; (ii) eliminating the need for a surgeon to measure the defect to be repaired intraoperatively in some embodiments; (iii) eliminating the need for a surgeon to shape the material during the implantation procedure; (iv) providing methods of evaluating curvature of the repair material based on bone or tissue images or based on intraoperative probing techniques; (v) providing methods of repairing joints with only minimal or, in some instances, no loss in bone stock; and (vi) improving postoperative joint congruity.

[0079] Thus, the methods described herein allow for the design and use of joint repair material that more precisely fits the defect (*e.g.*, site of implantation) and, accordingly, provides improved repair of the joint.

[0080] I. ASSESSMENT OF JOINTS AND ALIGNMENT

[0081] The methods and compositions described herein can be used to treat defects resulting from disease of the cartilage (*e.g.*, osteoarthritis), bone damage, cartilage damage, trauma, and/or degeneration due to overuse or age. The invention allows, among other things, a health practitioner to evaluate and treat such defects. The size, volume and shape of the area of interest can include only the region of cartilage that has the defect, but preferably will also include contiguous parts of the cartilage surrounding the cartilage defect.

[0082] As will be appreciated by those of skill in the art, size, curvature and/or thickness measurements can be obtained using any suitable technique. For example, one-dimensional, two-dimensional, and/or three-dimensional measurements can be obtained using suitable mechanical means, laser devices, 5 electromagnetic or optical tracking systems, molds, materials applied to the articular surface that harden and "memorize the surface contour," and/or one or more imaging techniques known in the art. Measurements can be obtained non-invasively and/or intraoperatively (e.g., using a probe or other surgical device). As will be appreciated by those of skill in the art, the thickness of the repair device 10 can vary at any given point depending upon the depth of the damage to the cartilage and/or bone to be corrected at any particular location on an articular surface.

[0083] As illustrated in **FIG. 1**, typically the process begins by first measuring the size of the area of diseased cartilage or cartilage loss **10**. 15 Thereafter the user can optionally measure the thickness of adjacent cartilage **20**. Once these steps are performed, the curvature of the articular surface is measured **30**. Alternatively, the curvature of subchondral bone can be measured.

[0084] Once the size of the defect is known, either an implant can be selected from a library **32** or an implant can be generated based on the patient 20 specific parameters obtained in the measurements and evaluation **34**. Prior to installing the implant in the joint, the implantation site is prepared **40** and then the implant is installed **42**. One or more of these steps can be repeated as necessary or desired as shown by the optional repeat steps **11, 21, 31, 33, 35, and 41**.

[0085] **A. IMAGING TECHNIQUES**

25 **[0086]** **I. Thickness and Curvature**

[0087] As will be appreciated by those of skill in the art, imaging techniques suitable for measuring thickness and/or curvature (e.g., of cartilage and/or bone) or size of areas of diseased cartilage or cartilage loss include the use of x-rays,

magnetic resonance imaging (MRI), computed tomography scanning (CT, also known as computerized axial tomography or CAT), optical coherence tomography, ultrasound imaging techniques, and optical imaging techniques. (See, also, International Patent Publication WO 02/22014 to Alexander, et al., published
5 March 21, 2002; U.S. Patent No. 6,373,250 to Tsoref et al., issued April 16, 2002; and Vandenberg et al. (2002) *Radiology* 222:430-436). Contrast or other enhancing agents can be employed using any route of administration, e.g. intravenous, intra-articular, etc.

[0088] In certain embodiments, CT or MRI is used to assess tissue, bone,
10 cartilage and any defects therein, for example cartilage lesions or areas of diseased cartilage, to obtain information on subchondral bone or cartilage degeneration and to provide morphologic or biochemical or biomechanical information about the area of damage. Specifically, changes such as fissuring, partial or full thickness cartilage loss, and signal changes within residual cartilage
15 can be detected using one or more of these methods. For discussions of the basic NMR principles and techniques, see MRI Basic Principles and Applications, Second Edition, Mark A. Brown and Richard C. Semelka, Wiley-Liss, Inc. (1999). For a discussion of MRI including conventional T1 and T2-weighted spin-echo imaging, gradient recalled echo (GRE) imaging, magnetization transfer contrast
20 (MTC) imaging, fast spin-echo (FSE) imaging, contrast enhanced imaging, rapid acquisition relaxation enhancement (RARE) imaging, gradient echo acquisition in the steady state (GRASS), and driven equilibrium Fourier transform (DEFT) imaging, to obtain information on cartilage, see Alexander, et al., WO 02/22014. Other techniques include steady state free precession, flexible equilibrium MRI and
25 DESS. Thus, in preferred embodiments, the measurements produced are based on three-dimensional images of the joint obtained as described in Alexander, et al., WO 02/22014 or sets of two-dimensional images ultimately yielding 3D information. Two-dimensional, and three-dimensional images, or maps, of the cartilage alone or in combination with a movement pattern of the joint, e.g. flexion

– extension, translation and/or rotation, can be obtained. Three-dimensional images can include information on movement patterns, contact points, contact zone of two or more opposing articular surfaces, and movement of the contact point or zone during joint motion. Two- and three-dimensional images can include information on biochemical composition of the articular cartilage. In addition, imaging techniques can be compared over time, for example to provide up-to-date information on the shape and type of repair material needed.

[0089] As will be appreciated by those of skill in the art, imaging techniques can be combined, if desired. For example, C-arm imaging or x-ray fluoroscopy can be used for motion imaging, while MRI can yield high resolution cartilage information. C-arm imaging can be combined with intra-articular contrast to visualize the cartilage.

[0090] Any of the imaging devices described herein can also be used intra-operatively (see, also below), for example using a hand-held ultrasound and/or optical probe to image the articular surface intra-operatively. **FIG. 2** illustrates a color reproduction of a three-dimensional thickness map of the articular surface on the distal femur. The dark holes within the cartilage indicate areas of full cartilage loss.

[0091] ii. **Anatomical and Mechanical Axes**

[0092] Imaging can be used to determine the anatomical and biomechanical axes of an extremity associated with a joint. Suitable tests include, for example, an x-ray, or an x-ray combined with an MRI. Typically, anatomical landmarks are identified on the imaging test results (e.g., the x-ray film) and those landmarks are then utilized to directly or indirectly determine the desired axes. Thus, for example, if surgery is contemplated in a hip joint, knee joint, or ankle joint, an x-ray can be obtained. This x-ray can be a weight-bearing film of the extremity, for example, a full-length leg film taken while the patient is standing. This film can be used to determine the femoral and tibial anatomical axes and to

estimate the biomechanical axes. As will be appreciated by those of skill in the art, these processes for identifying, e.g., anatomical and biomechanical axis of the joint can be applied to other joints without departing from the scope of the invention.

5 **[0093]** Anatomical and biomechanical axes can also be determined using other imaging modalities, including but not limited to, computed tomography and MRI. For example, a CT scan can be obtained through the hip joint, the knee joint, and the ankle joint. Optionally, the scan can be reformatted in the sagittal, coronal, or other planes. The CT images can then be utilized to identify
10 anatomical landmarks and to determine the anatomical and biomechanical axes of the hip joint, knee joint, and/or ankle joint. Similarly, an MRI scan can be obtained for this purpose. For example, an MRI scan of the thigh and pelvic region can be obtained using a body coil or a torso phased array coil. A high resolution scan of the knee joint can be obtained using a dedicated extremity coil. A scan of the
15 calf/tibia region and the ankle joint can be obtained again using a body coil or a torso phased array coil. Anatomical landmarks can be identified in each joint on these scans and the anatomical and biomechanical axes can be estimated using this information.

20 **[0094]** An imaging test obtained during weight-bearing conditions has some inherent advantages, in that it demonstrates normal as well as pathological loading and load distribution. A cross-sectional imaging study such as a CT scan or MRI scan has some advantages because it allows one to visualize and demonstrate the anatomical landmarks in three, rather than two, dimensions, thereby adding accuracy. Moreover, measurements can be performed in other
25 planes, such as the sagittal or oblique planes, that may not be easily accessible in certain anatomical regions using conventional radiography. In principle, any imaging test can be utilized for this purpose.

[0095] The biomechanical axis can be defined as the axis going from the center of the femoral head, between the condylar surfaces and through the ankle joint.

[0096] Computed Tomography imaging has been shown to be highly accurate for the determination of the relative anatomical and biomechanical axes of the leg (Testi Debora, Zannoni Cinzia, Cappello Angelo and Viceconti Marco. "Border tracing algorithm implementation for the femoral geometry reconstruction." *Comp. Meth. and Programs in Biomed.*, Feb. 14, 2000; Farrar MJ, Newman RJ, Mawhinney RR, King R. "Computed tomography scan scout film for measurement of femoral axis in knee arthroplasty." *J. Arthroplasty*. 1999 Dec; **14(8)**: 1030-1; Kim JS, Park TS, Park SB, Kim JS, Kim IY, Kim SI. "Measurement of femoral neck anteversion in 3D. Part 1: 3D imaging method." *Med. and Biol. Eng. and Computing*. **38(6)**: 603-609, Nov. 2000;; Akagi M, Yamashita E, Nakagawa T, Asano T, Nakamura T. "Relationship between frontal knee alignment and reference axis in the distal femur." *Clin. Ortho. and Related Res.* No. **388**, 147-156, 2001; Mahaisavariya B, Sitthiseripratip K, Tongdee T, Bohez E, Sloten JV, Oris P. "Morphological study of the proximal femur: a new method of geometrical assessment using 3 dimensional reverse engineering." *Med. Eng. and Phys.* **24** (2002) 617-622; Lam Li On, Shakespeare D. "Varus/Valgus alignment of the femoral component in total knee arthroplasty." *The Knee*, **10** (2003) 237-241).

[0097] The angles of the anatomical structures of the proximal and distal femur also show a certain variability level (i.e. standard deviation) comparable with the varus or valgus angle or the angle between the anatomical femoral axis and the biomechanical axis (Mahaisavariya B, Sitthiseripratip K, Tongdee T, Bohez E, Sloten JV, Oris P. "Morphological study of the proximal femur: a new method of geometrical assessment using 3 dimensional reverse engineering." *Med. Eng. and Phys.* **24** (2002) 617-622).. Thus, a preferred approach for assessing the axes is based on CT scans of the hip, knee and ankle joint or femur rather than only of the knee region.

[0098] CT has been shown to be efficient in terms of the contrast of the bone tissue with respect to surrounding anatomical tissue so the bone structures corresponding to the femur and tibia can be extracted very accurately with semi automated computerized systems (Mahaisavariya B, Sitthiseripratip K, Tongdee T, Bohez E, Sloten JV, Oris P. "Morphological study of the proximal femur: a new method of geometrical assessment using 3 dimensional reverse engineering." *Med. Eng. and Phys.* **24** (2002) 617-622; Testi Debora, Zannoni Cinzia, Cappello Angelo and Viceconti Marco. "Border tracing algorithm implementation for the femoral geometry reconstruction." *Comp. Meth. and Programs in Biomed.*, Feb. 14, 2000).

[0099] While 2-D CT has been shown to be accurate in the estimation of the biomechanical axis (Mahaisavariya B, Sitthiseripratip K, Tongdee T, Bohez E, Sloten JV, Oris P. "Morphological study of the proximal femur: a new method of geometrical assessment using 3 dimensional reverse engineering." *Med. Eng. and Phys.* **24** (2002) 617-622; Testi Debora, supra.; Lam Li On, Supra, 3-D CT has been shown to be more accurate for the estimation of the femoral anteversion angle (Kim JS, Park TS, Park SB, Kim JS, Kim IY, Kim SI. Measurement of femoral neck anteversion in 3D. Part 1: 3D imaging method. *Medical and Biological engineering and computing.* **38**(6): 603-609, Nov. 2000; Kim JS, Park TS, Park SB, Kim JS, Kim IY, Kim SI. Measurement of femoral neck anteversion in 3D. Part 1: 3D modeling method. *Medical and Biological engineering and computing.* **38**(6): 610-616, Nov. 2000). Farrar used simple CT 2-D scout views to estimate the femoral axis (Farrar MJ, Newman RJ, Mawhinney RR, King R. Computed tomography scan scout film for measurement of femoral axis in knee arthroplasty. *J. Arthroplasty.* 1999 Dec; **14**(8): 1030-1).

[0100] In one embodiment, 2-D sagittal and coronal reconstructions of CT slice images are used to manually estimate the biomechanical axis. One skilled in the art can easily recognize many different ways to automate this process. For example, a CT scan covering at least the hip, knee and ankle region is acquired.

This results in image slices (axial) which can be interpolated to generate the sagittal and coronal views.

[0101] Preprocessing (filtering) of the slice images can be used to improve the contrast of the bone regions so that they can be extracted accurately using simple thresholding or a more involved image segmentation tool like LiveWire or active contour models.

[0102] Identification of landmarks of interest like the centroid of the tibial shaft, the ankle joint, the intercondylar notch and the centroid of the femoral head can be performed. The biomechanical axis can be defined as the line connecting the proximal and the distal centroids, i.e. the femoral head centroid, the tibial or ankle joint centroid. The position of the intercondylar notch can be used for evaluation of possible deviations, errors or deformations including varus and valgus deformity.

[0103] In one embodiment, multiple imaging tests can be combined. For example, the anatomical and biomechanical axes can be estimated using a weight-bearing x-ray of the extremity or portions of the extremity. The anatomical information derived in this fashion can then be combined with a CT or MRI scan of one or more joints, such as a hip, knee, or ankle joint. Landmarks seen on radiography can then, for example, be cross-referenced on the CT or MRI scan. Axis measurements performed on radiography can be subsequently applied to the CT or MRI scans or other imaging modalities. Similarly, the information obtained from a CT scan can be compared with that obtained with an MRI or ultrasound scan. In one embodiment, image fusion of different imaging modalities can be performed. For example, if surgery is contemplated in a knee joint, a full-length weight-bearing x-ray of the lower extremity can be obtained. This can be supplemented by a spiral CT scan, optionally with intra-articular contrast of the knee joint providing high resolution three-dimensional anatomical characterization of the knee anatomy even including the menisci and cartilage. This information,

along with the axis information provided by the radiograph can be utilized to select or derive therapies, such as implants or surgical instruments.

[0104] In certain embodiments, it may be desirable to characterize the shape and dimension of intra-articular structures, including subchondral bone or the cartilage. This can be done using a CT scan, preferably a spiral CT scan of one or more joints. The spiral CT scan can optionally be performed using intra-articular contrast. Alternatively, an MRI scan can be performed. If CT is utilized, a full spiral scan, or a few selected slices, can be obtained through neighboring joints. Typically, a full spiral scan providing full three-dimensional characterization would be obtained in the joint for which therapy is contemplated. If implants, or molds, for surgical instruments are selected or shaped, using this scan, the subchondral bone shape can be accurately determined from the resultant image data. A standard cartilage thickness and, similarly, a standard cartilage loss can be assumed in certain regions of the articular surface. For example, a standard thickness of 2 mm of the articular cartilage can be applied to the subchondral bone in the anterior third of the medial and lateral femoral condyles. Similarly, a standard thickness of 2 mm of the articular cartilage can be applied to the subchondral bone in the posterior third of the medial and lateral femoral condyles. A standard thickness of 0 mm of the articular cartilage can be applied in the central weight-bearing zone of the medial condyle, and a different value can be applied to the lateral condyle. The transition between these zones can be gradual, for example, from 2 mm to 0 mm. These standard values of estimated cartilage thickness and cartilage loss in different regions of the joint can optionally be derived from a reference database. The reference database can include categories such as age, body mass index ("BMI"), severity of disease, pain, severity of varus deformity, severity of valgus deformity, Kellgren-Lawrence score, along with other parameters that are determined to be relative and useful. Use of a standard thickness for the articular cartilage can facilitate the imaging protocols required for pre-operative planning.

[0105] Alternatively, however, the articular cartilage can be fully characterized by performing a spiral CT scan of the joint in the presence of intra-articular contrast or by performing an MRI scan using cartilage sensitive pulse sequences.

5 **[0106]** The techniques described herein can be used to obtain an image of a joint that is stationary, either weight bearing or not, or in motion or combinations thereof. Imaging studies that are obtained during joint motion can be useful for assessing the load bearing surface. This can be advantageous for designing or selecting implants, e.g. for selecting reinforcements in high load areas, for surgical
10 tools and for implant placement, e.g. for optimizing implant alignment relative to high load areas.

[0107] **B. INTRAOPERATIVE MEASUREMENTS**

[0108] Alternatively, or in addition to, non-invasive imaging techniques described above, measurements of the size of an area of diseased cartilage or an
15 area of cartilage loss, measurements of cartilage thickness and/or curvature of cartilage or bone can be obtained intraoperatively during arthroscopy or open arthrotomy. Intraoperative measurements can, but need not, involve actual contact with one or more areas of the articular surfaces.

[0109] Devices suitable for obtaining intraoperative measurements of
20 cartilage or bone or other articular structures, and to generate a topographical map of the surface include but are not limited to, Placido disks and laser interferometers, and/or deformable materials or devices. (See, for example, U.S. Patent Numbers 6,382,028 to Woo et al., issued May 7, 2002; 6,057,927 to Levesque et al., issued May 2, 2000; 5,523,843 to Yamane et al. issued June 4,
25 1996; 5,847,804 to Sarver et al. issued December 8, 1998; and 5,684,562 to Fujieda, issued November 4, 1997).

[0110] **FIG. 3A** illustrates a Placido disk of concentrically arranged circles of light. The concentric arrays of the Placido disk project well-defined circles of light

of varying radii, generated either with laser or white light transported via optical fiber. The Placido disk can be attached to the end of an endoscopic device (or to any probe, for example a hand-held probe) so that the circles of light are projected onto the cartilage surface. **FIG. 3B** illustrates an example of a Placido disk
5 projected onto the surface of a fixed curvature. One or more imaging cameras can be used (*e.g.*, attached to the device) to capture the reflection of the circles. Mathematical analysis is used to determine the surface curvature. The curvature can then, for example, be visualized on a monitor as a color-coded, topographical map of the cartilage surface. Additionally, a mathematical model of the
10 topographical map can be used to determine the ideal surface topography to replace any cartilage defects in the area analyzed.

[0111] **FIG. 4** shows a reflection resulting from the projection of concentric circles of light (Placido disk) on each femoral condyle, demonstrating the effect of variation in surface contour on reflected circles.

15 **[0112]** Similarly a laser interferometer can also be attached to the end of an endoscopic device. In addition, a small sensor can be attached to the device in order to determine the cartilage surface or bone curvature using phase shift interferometry, producing a fringe pattern analysis phase map (wave front) visualization of the cartilage surface. The curvature can then be visualized on a
20 monitor as a color coded, topographical map of the cartilage surface. Additionally, a mathematical model of the topographical map can be used to determine the ideal surface topography to replace any cartilage or bone defects in the area analyzed. This computed, ideal surface, or surfaces, can then be visualized on the monitor, and can be used to select the curvature, or curvatures, of the
25 replacement cartilage.

[0113] One skilled in the art will readily recognize that other techniques for optical measurements of the cartilage surface curvature can be employed without departing from the scope of the invention. For example, a 2-dimensional or 3-dimensional map, such as that shown in **FIG. 5** and **FIG. 6**, can be generated.

[0114] Mechanical devices (*e.g.*, probes) can also be used for intraoperative measurements, for example, deformable materials such as gels, molds, any hardening materials (*e.g.*, materials that remain deformable until they are heated, cooled, or otherwise manipulated). See, *e.g.*, WO 02/34310 to
5 Dickson et al., published May 2, 2002. For example, a deformable gel can be applied to a femoral condyle. The side of the gel pointing towards the condyle can yield a negative impression of the surface contour of the condyle. The negative impression can then be used to determine the size of a defect, the depth of a defect and the curvature of the articular surface in and adjacent to a defect. This
10 information can be used to select a therapy, *e.g.* an articular surface repair system. In another example, a hardening material can be applied to an articular surface, *e.g.* a femoral condyle or a tibial plateau. The hardening material can remain on the articular surface until hardening has occurred. The hardening material can then be removed from the articular surface. The side of the
15 hardening material pointing towards the articular surface can yield a negative impression of the articular surface. The negative impression can then be used to determine the size of a defect, the depth of a defect and the curvature of the articular surface in and adjacent to a defect. This information can then be used to select a therapy, *e.g.* an articular surface repair system. In some embodiments,
20 the hardening system can remain in place and form the actual articular surface repair system.

[0115] In certain embodiments, the deformable material comprises a plurality of individually moveable mechanical elements. When pressed against the surface of interest, each element can be pushed in the opposing direction and
25 the extent to which it is pushed (deformed) can correspond to the curvature of the surface of interest. The device can include a brake mechanism so that the elements are maintained in the position that conforms to the surface of the cartilage and/or bone. The device can then be removed from the patient and analyzed for curvature. Alternatively, each individual moveable element can

MISSING UPON TIME OF PUBLICATION

sudden changes in curvature can be used to detect the boundaries of diseased cartilage or cartilage defects.

[0119] As described above, measurements can be made while the joint is stationary, either weight bearing or not, or in motion.

5 **[0120] II. REPAIR MATERIALS**

[0121] A wide variety of materials find use in the practice of the present invention, including, but not limited to, plastics, metals, crystal free metals, ceramics, biological materials (*e.g.*, collagen or other extracellular matrix materials), hydroxyapatite, cells (*e.g.*, stem cells, chondrocyte cells or the like), or combinations thereof. Based on the information (*e.g.*, measurements) obtained regarding the defect and the articular surface and/or the subchondral bone, a repair material can be formed or selected. Further, using one or more of these techniques described herein, a cartilage replacement or regenerating material having a curvature that will fit into a particular cartilage defect, will follow the contour and shape of the articular surface, and will match the thickness of the surrounding cartilage. The repair material can include any combination of materials, and typically include at least one non-pliable material, for example materials that are not easily bent or changed.

10
15

[0122] A. METAL AND POLYMERIC REPAIR MATERIALS

20 **[0123]** Currently, joint repair systems often employ metal and/or polymeric materials including, for example, prostheses which are anchored into the underlying bone (*e.g.*, a femur in the case of a knee prosthesis). See, *e.g.*, U.S. Patent No. 6,203,576 to Afriat, et al. issued March 20, 2001 and 6,322,588 to Ogle, et al. issued November 27, 2001, and references cited therein. A wide-
25 variety of metals are useful in the practice of the present invention, and can be selected based on any criteria. For example, material selection can be based on resiliency to impart a desired degree of rigidity. Non-limiting examples of suitable metals include silver, gold, platinum, palladium, iridium, copper, tin, lead,

antimony, bismuth, zinc, titanium, cobalt, stainless steel, nickel, iron alloys, cobalt alloys, such as Elgiloy®, a cobalt-chromium-nickel alloy, and MP35N, a nickel-cobalt-chromium-molybdenum alloy, and Nitinol™, a nickel-titanium alloy, aluminum, manganese, iron, tantalum, crystal free metals, such as Liquidmetal® alloys (available from LiquidMetal Technologies, www.liquidmetal.com), other metals that can slowly form polyvalent metal ions, for example to inhibit calcification of implanted substrates in contact with a patient's bodily fluids or tissues, and combinations thereof.

[0124] Suitable synthetic polymers include, without limitation, polyamides (e.g., nylon), polyesters, polystyrenes, polyacrylates, vinyl polymers (e.g., polyethylene, polytetrafluoroethylene, polypropylene and polyvinyl chloride), polycarbonates, polyurethanes, poly dimethyl siloxanes, cellulose acetates, polymethyl methacrylates, polyether ether ketones, ethylene vinyl acetates, polysulfones, nitrocelluloses, similar copolymers and mixtures thereof.

15 Bioresorbable synthetic polymers can also be used such as dextran, hydroxyethyl starch, derivatives of gelatin, polyvinylpyrrolidone, polyvinyl alcohol, poly[N-(2-hydroxypropyl) methacrylamide], poly(hydroxy acids), poly(epsilon-caprolactone), polylactic acid, polyglycolic acid, poly(dimethyl glycolic acid), poly(hydroxy butyrate), and similar copolymers can also be used.

[0125] Other materials would also be appropriate, for example, the polyketone known as polyetheretherketone (PEEK™). This includes the material PEEK 450G, which is an unfilled PEEK approved for medical implantation available from Victrex of Lancashire, Great Britain. (Victrex is located at www.matweb.com or see Boedeker www.boedeker.com). Other sources of this material include Gharda located in Panoli, India (www.ghardapolymers.com).

[0126] It should be noted that the material selected can also be filled. For example, other grades of PEEK are also available and contemplated, such as 30% glass-filled or 30% carbon filled, provided such materials are cleared for use in implantable devices by the FDA, or other regulatory body. Glass filled PEEK

reduces the expansion rate and increases the flexural modulus of PEEK relative to that portion which is unfilled. The resulting product is known to be ideal for improved strength, stiffness, or stability. Carbon filled PEEK is known to enhance the compressive strength and stiffness of PEEK and lower its expansion rate.

5 Carbon filled PEEK offers wear resistance and load carrying capability.

[0127] As will be appreciated, other suitable similarly biocompatible thermoplastic or thermoplastic polycondensate materials that resist fatigue, have good memory, are flexible, and/or deflectable have very low moisture absorption, and good wear and/or abrasion resistance, can be used without departing from the scope of the invention. The implant can also be comprised of polyetherketoneketone (PEKK).

[0128] Other materials that can be used include polyetherketone (PEK), polyetherketoneetherketoneketone (PEKEKK), and polyetheretherketoneketone (PEEKK), and generally a polyaryletheretherketone. Further other polyketones can be used as well as other thermoplastics.

[0129] Reference to appropriate polymers that can be used for the implant can be made to the following documents, all of which are incorporated herein by reference. These documents include: PCT Publication WO 02/02158 A1, dated Jan. 10, 2002 and entitled Bio-Compatible Polymeric Materials; PCT Publication WO 02/00275 A1, dated Jan. 3, 2002 and entitled Bio-Compatible Polymeric Materials; and PCT Publication WO 02/00270 A1, dated Jan. 3, 2002 and entitled Bio-Compatible Polymeric Materials.

[0130] The polymers can be prepared by any of a variety of approaches including conventional polymer processing methods. Preferred approaches include, for example, injection molding, which is suitable for the production of polymer components with significant structural features, and rapid prototyping approaches, such as reaction injection molding and stereo-lithography. The substrate can be textured or made porous by either physical abrasion or chemical

alteration to facilitate incorporation of the metal coating. Other processes are also appropriate, such as extrusion, injection, compression molding and/or machining techniques. Typically, the polymer is chosen for its physical and mechanical properties and is suitable for carrying and spreading the physical load between
5 the joint surfaces.

[0131] More than one metal and/or polymer can be used in combination with each other. For example, one or more metal-containing substrates can be coated with polymers in one or more regions or, alternatively, one or more polymer-containing substrate can be coated in one or more regions with one or
10 more metals.

[0132] The system or prosthesis can be porous or porous coated. The porous surface components can be made of various materials including metals, ceramics, and polymers. These surface components can, in turn, be secured by various means to a multitude of structural cores formed of various metals.
15 Suitable porous coatings include, but are not limited to, metal, ceramic, polymeric (e.g., biologically neutral elastomers such as silicone rubber, polyethylene terephthalate and/or combinations thereof) or combinations thereof. See, e.g., U.S. Pat. No. 3,605,123 to Hahn, issued September 20, 1971. U.S. Pat. No. 3,808,606 to Tronzo issued May 7, 1974 and U.S. Pat. No. 3,843,975 to Tronzo
20 issued October 29, 1974; U.S. Pat. No. 3,314,420 to Smith issued April 18, 1967; U.S. Pat. No. 3,987,499 to Scharbach issued October 26, 1976; and German Offenlegungsschrift 2,306,552. There can be more than one coating layer and the layers can have the same or different porosities. See, e.g., U.S. Pat. No. 3,938,198 to Kahn, et al., issued February 17, 1976.

[0133] The coating can be applied by surrounding a core with powdered polymer and heating until cured to form a coating with an internal network of interconnected pores. The tortuosity of the pores (e.g., a measure of length to diameter of the paths through the pores) can be important in evaluating the probable success of such a coating in use on a prosthetic device. See, also, U.S.

Pat. No. 4,213,816 to Morris issued July 22, 1980. The porous coating can be applied in the form of a powder and the article as a whole subjected to an elevated temperature that bonds the powder to the substrate. Selection of suitable polymers and/or powder coatings can be determined in view of the teachings and references cited herein, for example based on the melt index of each.

[0134] . B. BIOLOGICAL REPAIR MATERIAL

[0135] Repair materials can also include one or more biological material either alone or in combination with non-biological materials. For example, any base material can be designed or shaped and suitable cartilage replacement or regenerating material(s) such as fetal cartilage cells can be applied to be the base. The cells can be then be grown in conjunction with the base until the thickness (and/or curvature) of the cartilage surrounding the cartilage defect has been reached. Conditions for growing cells (*e.g.*, chondrocytes) on various substrates in culture, *ex vivo* and *in vivo* are described, for example, in U.S. Patent Nos. 5,478,739 to Slivka et al. issued December 26, 1995; 5,842,477 to Naughton et al. issued December 1, 1998; 6,283,980 to Vibe-Hansen et al., issued September 4, 2001, and 6,365,405 to Salzmann et al. issued April 2, 2002. Non-limiting examples of suitable substrates include plastic, tissue scaffold, a bone replacement material (*e.g.*, a hydroxyapatite, a bioresorbable material), or any other material suitable for growing a cartilage replacement or regenerating material on it.

[0136] Biological polymers can be naturally occurring or produced in vitro by fermentation and the like. Suitable biological polymers include, without limitation, collagen, elastin, silk, keratin, gelatin, polyamino acids, cat gut sutures, polysaccharides (*e.g.*, cellulose and starch) and mixtures thereof. Biological polymers can be bioresorbable.

[0137] Biological materials used in the methods described herein can be autografts (from the same subject); allografts (from another individual of the same species) and/or xenografts (from another species). See, also, International Patent Publications WO 02/22014 to Alexander et al. published March 21, 2002 and WO 5 97/27885 to Lee published August 7, 1997. In certain embodiments autologous materials are preferred, as they can carry a reduced risk of immunological complications to the host, including re-absorption of the materials, inflammation and/or scarring of the tissues surrounding the implant site.

[0138] In one embodiment of the invention, a probe is used to harvest 10 tissue from a donor site and to prepare a recipient site. The donor site can be located in a xenograft, an allograft or an autograft. The probe is used to achieve a good anatomic match between the donor tissue sample and the recipient site. The probe is specifically designed to achieve a seamless or near seamless match between the donor tissue sample and the recipient site. The probe can, for 15 example, be cylindrical. The distal end of the probe is typically sharp in order to facilitate tissue penetration. Additionally, the distal end of the probe is typically hollow in order to accept the tissue. The probe can have an edge at a defined distance from its distal end, e.g. at 1 cm distance from the distal end and the edge can be used to achieve a defined depth of tissue penetration for harvesting. The 20 edge can be external or can be inside the hollow portion of the probe. For example, an orthopedic surgeon can take the probe and advance it with physical pressure into the cartilage, the subchondral bone and the underlying marrow in the case of a joint such as a knee joint. The surgeon can advance the probe until the external or internal edge reaches the cartilage surface. At that point, the edge 25 will prevent further tissue penetration thereby achieving a constant and reproducible tissue penetration. The distal end of the probe can include one or more blades, saw-like structures, or tissue cutting mechanism. For example, the distal end of the probe can include an iris-like mechanism consisting of several small blades. The blade or blades can be moved using a manual, motorized or

electrical mechanism thereby cutting through the tissue and separating the tissue sample from the underlying tissue. Typically, this will be repeated in the donor and the recipient. In the case of an iris-shaped blade mechanism, the individual blades can be moved so as to close the iris thereby separating the tissue sample from the donor site.

5

[0139] In another embodiment of the invention, a laser device or a radiofrequency device can be integrated inside the distal end of the probe. The laser device or the radiofrequency device can be used to cut through the tissue and to separate the tissue sample from the underlying tissue.

10 **[0140]** In one embodiment of the invention, the same probe can be used in the donor and in the recipient. In another embodiment, similarly shaped probes of slightly different physical dimensions can be used. For example, the probe used in the recipient can be slightly smaller than that used in the donor thereby achieving a tight fit between the tissue sample or tissue transplant and the recipient site. The probe used in the recipient can also be slightly shorter than that used in the donor thereby correcting for any tissue lost during the separation or cutting of the tissue sample from the underlying tissue in the donor material.

15

[0141] Any biological repair material can be sterilized to inactivate biological contaminants such as bacteria, viruses, yeasts, molds, mycoplasmas and parasites. Sterilization can be performed using any suitable technique, for example radiation, such as gamma radiation.

20

[0142] Any of the biological materials described herein can be harvested with use of a robotic device. The robotic device can use information from an electronic image for tissue harvesting.

25

[0143] In certain embodiments, the cartilage replacement material has a particular biochemical composition. For instance, the biochemical composition of the cartilage surrounding a defect can be assessed by taking tissue samples and chemical analysis or by imaging techniques. For example, WO 02/22014 to

Alexander describes the use of gadolinium for imaging of articular cartilage to monitor glycosaminoglycan content within the cartilage. The cartilage replacement or regenerating material can then be made or cultured in a manner, to achieve a biochemical composition similar to that of the cartilage surrounding the
5 implantation site. The culture conditions used to achieve the desired biochemical compositions can include, for example, varying concentrations. Biochemical composition of the cartilage replacement or regenerating material can, for example, be influenced by controlling concentrations and exposure times of certain nutrients and growth factors.

10 **[0144] III. DEVICES DESIGN**

[0145] A. CARTILAGE MODELS

[0146] Using information on thickness and curvature of the cartilage, a physical model of the surfaces of the articular cartilage and of the underlying bone can be created. This physical model can be representative of a limited area within
15 the joint or it can encompass the entire joint. For example, in the knee joint, the physical model can encompass only the medial or lateral femoral condyle, both femoral condyles and the notch region, the medial tibial plateau, the lateral tibial plateau, the entire tibial plateau, the medial patella, the lateral patella, the entire patella or the entire joint. The location of a diseased area of cartilage can be
20 determined, for example using a 3D coordinate system or a 3D Euclidian distance as described in WO 02/22014.

[0147] In this way, the size of the defect to be repaired can be determined. As will be apparent, some, but not all, defects will include less than the entire cartilage. Thus, in one embodiment of the invention, the thickness of the normal
25 or only mildly diseased cartilage surrounding one or more cartilage defects is measured. This thickness measurement can be obtained at a single point or, preferably, at multiple points, for example 2 point, 4-6 points, 7-10 points, more than 10 points or over the length of the entire remaining cartilage. Furthermore,

once the size of the defect is determined, an appropriate therapy (*e.g.*, articular repair system) can be selected such that as much as possible of the healthy, surrounding tissue is preserved.

[0148] In other embodiments, the curvature of the articular surface can be measured to design and/or shape the repair material. Further, both the thickness of the remaining cartilage and the curvature of the articular surface can be measured to design and/or shape the repair material. Alternatively, the curvature of the subchondral bone can be measured and the resultant measurement(s) can be used to either select or shape a cartilage replacement material. For example, the contour of the subchondral bone can be used to re-create a virtual cartilage surface: the margins of an area of diseased cartilage can be identified. The subchondral bone shape in the diseased areas can be measured. A virtual contour can then be created by copying the subchondral bone surface into the cartilage surface, whereby the copy of the subchondral bone surface connects the margins of the area of diseased cartilage.

[0149] Turning now to **FIGS. 7A-H**, various stages of knee resurfacing steps are shown. **FIG. 7A** illustrates an example of normal thickness cartilage **700** in the anterior, central and posterior portion of a femoral condyle **702** with a cartilage defect **705** in the posterior portion of the femoral condyle. **FIG. 7B** shows the detection of a sudden change in thickness indicating the margins of a cartilage defect **710** that would be observed using the imaging techniques or the mechanical, optical, laser or ultrasound techniques described above. **FIG. 7c** shows the margins of a weight-bearing surface **715** mapped onto the articular cartilage **700**. Cartilage defect **705** is located within the weight-bearing surface **715**.

[0150] **FIG. 7D** shows an intended implantation site (stippled line) **720** and cartilage defect **705**. In this depiction, the implantation site **720** is slightly larger than the area of diseased cartilage **705**. **FIG. 7E** depicts placement of a single component articular surface repair system **725**. The external surface of the

articular surface repair system **726** has a curvature that seamlessly extends from the surrounding cartilage **700** resulting in good postoperative alignment between the surrounding normal cartilage **700** and the articular surface repair system **725**.

[0151] FIG. 7F shows an exemplary multi-component articular surface repair system **730**. The distal surface **733** of the second component **732** has a curvature that extends from that of the adjacent subchondral bone **735**. The first component **736** has a thickness t and surface curvature **738** that extends from the surrounding normal cartilage **700**. In this embodiment, the second component **732** could be formed from a material with a Shore or Rockwell hardness that is greater than the material forming the first component **736**, if desired. Thus it is contemplated that the second component **732** having at least portion of the component in communication with the bone of the joint is harder than the first component **736** which extends from the typically naturally softer cartilage material. Other configurations, of course, are possible without departing from the scope of the invention.

[0152] By providing a softer first component **736** and a firmer second component **732**, the overall implant can be configured so that its relative hardness is analogous to that of the bone-cartilage or bone-meniscus area that it abuts. Thus, the softer material first component **736**, being formed of a softer material, could perform the cushioning function of the nearby meniscus or cartilage.

[0153] FIG. 7G shows another single component articular surface repair system **740** with a peripheral margin **745** which is configured so that it is substantially non-perpendicular to the surrounding or adjacent normal cartilage **700**. FIG. 7H shows a multi-component articular surface repair system **750** with a first component **751** and a second component **752** similar to that shown in FIG. 7G with a peripheral margin **745** of the second component **745** substantially non-perpendicular to the surrounding or adjacent normal cartilage **700**.

[0154] Now turning to **FIGS. 8A-E**, these figures depict exemplary knee imaging and resurfacing processes. **FIG. 8A** depicts a magnified view of an area of diseased cartilage **805** demonstrating decreased cartilage thickness when compared to the surrounding normal cartilage **800**. The margins **810** of the defect have been determined. **FIG. 8B** depicts the measurement of cartilage thickness **815** adjacent to the defect **805**. **FIG. 8C** depicts the placement of a multi-component mini-prosthesis **824** for articular resurfacing. The thickness **820** of the first component **823** closely approximates that of the adjacent normal cartilage **800**. The thickness can vary in different regions of the prosthesis. The curvature of the distal portion **824** of the first component **823** closely approximates an extension of the normal cartilage **800** surrounding the defect. The curvature of the distal portion **826** of the second component **825** is a projection of the surface **827** of the adjacent subchondral bone **830** and can have a curvature that is the same, or substantially similar, to all or part of the surrounding subchondral bone.

[0155] **FIG. 8D** is a schematic depicting placement of a single component mini-prosthesis **840** utilizing anchoring stems **845**. As will be appreciated by those of skill in the art, a variety of configurations, including stems, posts, and nubs can be employed. Additionally, the component is depicted such that its internal surface **829** is located within the subchondral bone **830**. In an alternative construction, the interior surface **829** conforms to the surface of the subchondral bone **831**.

[0156] **FIG. 8E** depicts placement of a single component mini-prosthesis **840** utilizing anchoring stems **845** and an opening at the external surface **850** for injection of bone cement **855** or other suitable material. The injection material **855** can freely extravasate into the adjacent bone and marrow space from several openings at the undersurface of the mini-prosthesis **860** thereby anchoring the mini-prosthesis.

[0157] **FIGS. 9A-C**, depict an alternative knee resurfacing device. **FIG. 9A** depicts a normal thickness cartilage in the anterior, central and posterior portion of a femoral condyle **900** and a large area of diseased cartilage **905** toward the

posterior portion of the femoral condyle. FIG. 9B depicts placement of a single component articular surface repair system **910**. Again, the implantation site has been prepared with a single cut **921**, as illustrated. However, as will be appreciated by those of skill in the art, the repair system can be perpendicular to the adjacent normal cartilage **900** without departing from the scope of the invention. The articular surface repair system is not perpendicular to the adjacent normal cartilage **900**. FIG. 9c depicts a multi-component articular surface repair system **920**. Again, the implantation site has been prepared with a single cut (cut line shown as **921**). The second component **930** has a curvature similar to the extended surface **930** adjacent subchondral bone **935**. The first component **940** has a curvature that extends from the adjacent cartilage **900**.

[0158] B. DEVICE MODELING IN SITU

[0159] Another approach to repairing a defect is to model defect repair system in situ, as shown in FIGS. 10A-B. As shown in FIG. 10A, one approach would be to insert a hollow device, such as a balloon, into the target joint **1000**. Any device capable of accepting, for example, injections of material would be suitable. Suitable injection materials include, for example, polymers and other materials discussed in Section II, above, can be used without departing from the scope of the invention.

[0160] In one embodiment it is contemplated that an insertion device has a substantially fixed shape that matches at least one articular surface or subchondral bone of the joint. After inserting the insertion device **1000**, material is injected into the joint through the insertion device **1010** where it then hardens in situ, forming an implant **1052**. The injection material can optionally bond to the device while hardening.

[0161] Alternatively, the implant can be removed after hardening **1020** for further processing **1030**, such as polishing, e.g. as described Section IV.

[0162] Where the implant is removable after hardening in situ, it can be preferable to have the implant be formed so that it is collapsible, foldable or generally changeable in shape to facilitate removal. After processing, the implant can be reinstalled **1040**.

5 **[0163]** One or more molds can be applied to one or more articular surfaces. The mold can have an internal surface facing the articular surface that substantially conforms to the shape of the articular cartilage and/or the shape of the subchondral bone. A hardening material including a polymer or metals can then be injected through an opening in the mold. The opening can include a
10 membrane that allows insertion of an injection device such as a needle. The membrane helps to avoid reflux of the injected material into the joint cavity. Alternatively, the mold can be made of a material that provides sufficient structural rigidity to allow hardening of the injected substance with the proper shape while allowing for placement of needles and other devices through the mold.

15 **[0164]** Additionally, the implant device can be composed of a plurality of subcomponents, where the volume or size of each of the subcomponents is smaller than the volume of the implant. The different subcomponents can be connected or assembled prior to insertion into the joint **1050** (whether outside the body or adjacent the joint but within or substantially within the body), or, in some
20 instances, can be assembled after insertion to the joint **1052**. The subcomponents can be disassembled inside the joint, or adjacent the joint, once hardening of the injectable material has occurred.

[0165] Additionally, the implant can be fixed to the surface of the bone after implantation **1060** For example, fixation mechanisms can include mechanical
25 structures such as fins, keels, teeth and pegs or non-mechanical means, such as bone cement, *etc.* Typically after the device is implanted and/or fixed within the joint, the functionality of the implant is tested **1070** to determine whether it enables the joint to engage in a desired range of motion. As will be appreciated by those of skill in the art, one or more of these steps can be repeated without departing from

the scope of the invention, as shown by the optional repeat steps **1001**, **1011**, **1021**, **1031**, **1041**, **1051**, **1053**, **1061** and **1071**.

5 **[0166]** As shown in FIG. 10B, another approach would be to insert a retaining device into the target joint **1002**. Any device capable of accepting, for example, injections of material would be suitable. Suitable materials include, for example, polymers and other materials discussed in Section II, above, can be used without departing from the scope of the invention.

10 **[0167]** In one embodiment it is contemplated that an insertion device has a substantially fixed shape that matches at least one articular surface or subchondral bone of the joint. After inserting the retaining device **1002**, material is injected into a hollow area formed between the retaining device and the joint surface through an aperture **1012** where it then hardens in situ, forming an implant **1052**. The injection material can optionally bond to the device while hardening.

15 **[0168]** Alternatively, the implant can be removed after hardening **1020** for further processing **1030**, such as polishing, *e.g.* as described Section IV.

20 **[0169]** Where the implant is removable after hardening in situ, it can be preferable to have the implant be formed so that it is collapsible, foldable or generally changeable in shape to facilitate removal. After processing, the implant can be reinstalled **1040**.

25 **[0170]** Additionally, the implant device can be composed of a plurality of subcomponents, where the volume or size of each of the subcomponents is smaller than the volume of the implant. The different subcomponents can be connected or assembled prior to insertion into the joint **1050** (whether outside the body or adjacent the joint but within or substantially within the body), or, in some instances, can be assembled after insertion to the joint **1052**. The subcomponents can be disassembled inside the joint, or adjacent the joint, once hardening of the injectable material has occurred.

- [0171]** Additionally, the implant can be fixed to the surface of the bone after implantation **1060** For example, fixation mechanisms can include mechanical structures such as fins, keels, teeth and pegs or non-mechanical means, such as bone cement, *etc.* Typically after the device is implanted and/or fixed within the joint, the functionality of the implant is tested **1070** to determine whether it enables the joint to engage in a desired range of motion. As will be appreciated by those of skill in the art, one or more of these steps can be repeated without departing from the scope of the invention, as shown by the optional repeat steps **1003, 1013, 1021, 1031, 1041, 1051, 1053, 1061** and **1071**.
- [0172]** Prior to performing the method shown in FIG. 10B, one or more holes or apertures can be drilled into the surface of the bone at an angle either perpendicular to the bone surface or set at an angle. Upon injecting material underneath the retaining device, the material embeds within the holes and form pegs upon hardening.
- [0173]** In one contemplated embodiment, at least a portion of the implantation device remains in situ after hardening of the injection material. In this scenario, the implantation device can be formed from a bio-resorbable material. In this instance, the container forming the implantation device can be resorbed, typically some time after hardening of the injection material.
- [0174]** The shape of the implantation device can be fixed. Where the shape is fixed, an imaging test or intraoperative measurement can be used to either shape or select the best fitting device for a particular patient, for example, using the imaging techniques and intraoperative measurement techniques described in **SECTIONS IA-B**, above.
- [0175]** In other embodiments, portions of the device can be rigid, or substantially rigid, while other portions of the device are deformable or malleable. Alternatively, a portion of the device can be relatively more rigid than another portion, without any requirement that any section be rigid, deformable or

malleable, but that sections vary in hardness relative to another section. In this manner the shape of the rigid, substantially rigid, or relatively more rigid section can be determined, for example, using an imaging test. In contrast, it is possible that the malleable, deformable, or relatively more deformable portion of the
5 implantation device can then take the shape of one or more articular surface in situ. This occurs particularly after the implantation material has been injected and while the material is hardening in situ. In still other embodiments, the entire device can be deformable.

[0176] In other embodiments, the implantation device can be expandable or
10 collapsible. For example, a support structure such as a Nitinol™ mesh can be inserted into the joint. Insertion can occur via, for example, a catheter or an arthroscopy portal. Once inside the joint, the implantation device can then be expanded. The implantation device can include a receptacle, such as a bag, to receive the injection of hardening material, such as polyethylene or other liquid
15 including metal preparations. The receptacle portion of the implantation device can be bio-resorbable and/or can bond with the injected material. Alternatively, the implantation device can be removed subsequent to injecting the material. Where a supporting material is used, the supporting material can be removed concurrently or subsequent to the removal of the implantation device, either via an incision or
20 by collapsing the implantation device and removing it via, for example, the catheter or arthroscopy portal.

[0177] In another embodiment, a balloon such as that shown in **Figs. 11A-E**, can be used as the implantation device. Different balloon shapes and sizes can be made available. A detailed description of all possible shapes and sizes for the
25 balloons is not included to avoid obscuring the invention, but would be apparent to those of skill in the art. Where a balloon is used, it can be inserted into a joint and inflated. The size, height, shape and position of the balloon can be evaluated arthroscopically or via an open incision or using, for example, an imaging test relative to the articular surface and the other articular strictures. Range of motion

testing can be performed in order to ensure adequate size, shape and position of the device during the full range of motion.

[0178] After insertion, the balloon can be slowly injected with, for example, a self-hardening material, or material that hardens upon activation. Suitable materials are described below and would be apparent to those of skill in the art. Typically, upon injection, the material is in a fluid or semi-fluid state. The material expands the balloon as it is injected which results in the balloon taking on the shape of the articular surface, for example as shown in **FIG. 11A**, and other articular structures such that it fills the defect.

[0179] The balloon can be slowly injected with a self hardening or hardening material such as a polymer and even metals. The material is initially in a fluid or semi-fluid state. The material expands the balloon whereby the shape of the balloon will take substantially the shape of the articular surface(s) and other articular structures. The polymer will subsequently harden inside the balloon thereby substantially taking the shape of the articular cavity and articular surface(s) / structures. The balloon can also be composed of a bio-resorbable material. The balloon can also be removed after the procedure.

[0180] Comparing, for example, the embodiments illustrated in **FIGS. 11A-C**, **FIG. 11A** illustrates a single balloon **1100** inserted between two joint surfaces **1102, 1104** of a joint **1110**. In this figure, the joint surfaces are illustrated with associated cartilage **1106, 1108**. The proximal end **1112** of the balloon is configured to communicate with a device that enables the balloon to be inflated, *e.g.* by filling the balloon **1100** with a substance. Substances include, but are not limited to, air, polymers, crystal free metals, or any other suitable material, such as those discussed in Section II above. The balloon **1100** of **FIG. 11A** is configured such that the distal end of the balloon **1114** does not extend beyond distal end of the joint **1120** (where the distal end of the joint is defined relative to the area of the joint where the balloon entered the joint).

[0181] FIG. 11B illustrates an alternative balloon **1130** wherein the distal end **1114** of the balloon **1130** and the proximal end **1113** of the balloon **1130** extends beyond the distal **1120** and proximal **1122** end of the joint. This extension can be optimized for flexion and extension by using different balloon sizes.

5 **[0182]** FIG. 11c illustrates a balloon **1140** wherein the balloon **1140** is configured such that the distal end **1114** of the balloon **1140** extends beyond the distal **1120** of the joint while the proximal end **1114** of the balloon **1140** does not extend beyond the end of the joint. As will be appreciated by those of skill in the art, other permutations are possible without departing from the scope of the invention.

10 **[0182]** Additionally, a sharp instrument such as a scalpel can be inserted into the balloon or adjacent to the balloon and the balloon can be cut or slit. The balloon can then be pulled back from the hardened material and removed from the joint, preferably through a catheter or an arthroscopy portal.

[0183] More than one balloon can be used as illustrated in FIGS. 11D-G. Where a plurality of balloons used, the balloons can be configured such that the balloons are inserted side-by-side as shown by **1150, 1152** in FIG. 11D, inserted in different compartments as shown by **1154, 1156** in FIG. 11E, one or more balloons are encompassed within the lumen of another balloon, as shown by **1160, 1162** and **1170, 1172, 1174** in FIGS. 11F-G, in a top-bottom relationship, and/or combinations thereof.

20 **[0184]** Each balloon can have the same or different wall thickness or can be composed of the same or different materials. As a result of differences in material, a person of skill in the art will appreciate that the amount of pressure required to expand each of the balloons can vary either uniformly or in a non-uniform fashion. These pressures would be known to a person of skill in the art and are not discussed at length herein to avoid obscuring the invention.

25 **[0185]** For example, in one scenario the superior and inferior surface of a first, inner balloon, can have a low inflation pressure relative to a second balloon.

Thus, as the material is injected, the pressure created inside the lumen of the balloon is directly transmitted to one or more articular surface. In this manner, the distance between the two articular surfaces can be controlled and a minimum distance can be obtained ensuring a sufficient thickness of the resultant implant.

5 This embodiment can be useful in areas within or bordering the contact zone of the articular surface.

[0186] A second outer or peripheral balloon can be provided that requires a higher inflation pressure relative to the first balloon. The inner, low inflation pressure balloon can be placed in the weight-bearing zone. The same balloon
10 can also have different wall properties in different regions of the balloon, *e.g.* a rigid wall with high inflation pressures in the periphery and a less rigid wall with intermediate or low inflation pressures in the center.

[0187] Alternatively, a first balloon, having a low inflation pressure relative to a second balloon is provided in an area bordering the contact zone of the
15 articular surface. Again, as material is injected, the pressure created inside the lumen of the balloon is directly transmitted to one or more articular surface. In this manner, the distance between the two articular surfaces can be controlled and a minimum distance can be obtained ensuring a sufficient thickness of the resultant implant.

20 **[0188]** A second balloon can be provided at an area where there is relatively more weight bearing. This balloon can be configured to require a higher inflation pressure relative to the first balloon.

[0189] Differences in wall thickness, pressure tolerances and expandability of balloons can also be used to influence the resulting shape of the injected
25 material.

[0190] The results of using inflation devices, or balloons, with differing wall thicknesses or pressure tolerances is shown in **FIGS. 12A-F**. As shown in **FIG. 12A** the balloon **1200** has an upper surface **1210** and a lower surface **1212** along with

a proximal end **1214** and a distal end **1216**. The relative pressure tolerance of the balloon or inflation device **1200** is lower on the lower surface **1212** than the upper surface **1210**. As a result, the upper surface of the balloon **1210** has a relatively flat configuration relative to its corresponding joint surface while the lower surface

5 **1212** has a relatively conforming shape relative to its corresponding joint surface.

[0191] Turning now to **FIG. 12B**, the inflation device used **1220** has a relatively constant pressure tolerance that is relatively high which results in both the upper surface **1210** and the lower surface **1212** having relatively flat configurations relative to each of its corresponding joint surfaces, regardless of

10 the joint surface anatomy.

[0192] **FIG. 12c** illustrates a balloon **1230** having a low inflation pressure at its proximal **1214** and distal **1216** ends, with a higher inflation pressure at a central region **1218**. The result of this configuration is that when the balloon is inflated, the proximal and distal ends inflate to a greater profile (e.g., height) than the

15 central region. The inflation pressure of the central region, although higher than the proximal and distal ends, can be set such that the central region has a relatively flat configuration relative to the corresponding joint surfaces, as shown, or can be configured to achieve the result shown in **FIG. 12A**.

[0193] As will be appreciated by those of skill in the art, any of these

20 balloons can be configured to have varying properties resulting in portions of the wall being less rigid than other portions, within the same balloon, e.g. a rigid wall with high inflation pressures in the periphery and a less rigid wall with intermediate or low inflation pressures in the center. Where there is more than one thickness to the balloon, it could, for example, have less stiffness anteriorly; greater stiffness

25 centrally, and less stiffness posteriorly. The wall thickness variability will enable the device to accommodate shape formation. Central thickness will help prevent the device from fully conforming to the irregular surface of the joint, which may be important where there are irregularities to the joint surface, such as bone spurs. Alternatively, if the central portion is of less stiffness than the anterior and

posterior sections, the device would be configured to conform more closely to the shape of the joint surface, including any irregularities. The closer the device conforms to the joint shape, the more the device seats within the joint.

5 **[0194]** Optionally, the surgeon can elect to remove surface irregularities, including bone spurs. This can be done using known techniques such as arthroscopy or open arthrotomy.

10 **[0195]** Where more than one balloon is used, the different balloons can have different shapes and sizes. Shape and size can be adjusted or selected for a given patient and joint. In addition to size and shape differences of the balloons, each of the balloons can also be configured to have different and/or varying wall thicknesses. For example, one balloon could be configured with a central portion that is less stiff than the anterior and posterior sections while a second balloon could be configured so that the central portion is of greater stiffness than the anterior and posterior section.

15 **[0196]** Figs. 12D-E illustrate configurations using two balloons. As shown in FIG. 12D the first balloon **1244** sits within a second balloon **1242** to form an inflation device **1240**. In this embodiment, the inferior surface **1246** of the external second balloon **1242** is configured with an inflation pressure that enables at least one surface of the device to conform, or substantially conform, to the
20 corresponding joint surface. FIG. 12E also illustrates a two balloon configuration **1250** with a first balloon **1254** and a second balloon **1252**. In this embodiment, the inflation pressure of the device is configured such that the surface does not substantially conform to the corresponding joint surface.

25 **[0197]** Figs. 13A-J(1-3) illustrate a variety of cross-sections possible for the embodiments shown in Figs. 11-12. These embodiments illustrate possible profiles achieved with a single balloon (Figs. 13A(1-3)); a dual balloon embodiment wherein one balloon fits within a second balloon in approximately a central position (FIG. 13B(1-3)) or in an off-centered position within a second balloon

(FIGS. 13D(1-3)); a tri-balloon set-up where two balloons fit within a first balloon (FIGS. 13C(1-3)), three balloons are positioned next to each other (FIGS. 13H(1-3)), or two balloons are adjacent each other while one balloon has another balloon within its lumen (FIGS. 13E(2-3), F(2), G(2)); a four balloon set-up where two balloons are adjacent each other and each one has a balloon within its lumen (FIG. 13G(3)) or three balloons are adjacent each other with at least one of the three balloons having another balloon within its lumen (FIGS. 13I(2-3)), or a five balloon set up where three balloons are positioned adjacent each other and two of the three balloons have balloons within its lumen (FIG. 13J(1)). As will be appreciated by those of skill in the art, other combinations and profiles are achievable using the teachings of the invention without departing from the scope of the invention. All possible combinations have not been illustrated in order to avoid obscuring the invention.

[0198] In another embodiment, a probe can be inserted into the balloon or the device. The probe can be utilized for measuring the device thickness (e.g. minima and maxima). In this and other embodiments, the balloon can be initially injected with a test material that is typically not hardening. Once inside the balloon or the device, the thickness of the device or the balloon can be measured, e.g. for a given inflation pressure. In this manner, a sufficient minimum implant thickness can be ensured. Probes to measure the thickness of the device or the balloon include, but are not limited to ultrasound, including A-, B- or C-scan.

[0199] Turning now to FIGS. 14A-J which illustrate the cartilage repair system described in FIG. 10B utilizing the retaining device. FIG. 14A and D illustrate a cartilage defect **1501** on an articular surface **1500** in the sagittal plane **S** and the coronal plane **C**. The surgeon debrides the defect thereby optionally creating smooth margins **1502**.

[0200] A retaining device **1510** is applied to the defect **1501** to define a cavity **1520**. A hardening material can be injected into an aperture **1512** in the retaining device **1510**. Suitable materials include, but not limited to, a polymer or a

crystal free metal. Additionally, as will be appreciated by those of skill in the art, the material injected can be initially in powder form with a liquid catalyst or hardening material injected thereafter.

[0201] As illustrated in **FIGS. 14G**, the surface of the bone **1550** can be prepared, e.g. by curette or drill, so that the surface of the bone **1550** defines small teeth, holes, or anchoring members, **1552** that help anchor the resulting device to the articular surface **1550**. As shown in **FIG. 14G(2)** and **(5)** the drill holes can be drilled parallel in relation to one another, where there are more than two, and perpendicular to the surface of the subchondral bone **1552**. Alternatively, the drill holes can be drilled at an angle in relationship to each other and at a angle that is not perpendicular to the subchondral bone **1553** as illustrated in **FIG. 15G(3-4)**. As will be appreciated by those of skill in the art, one or more pegs can be created on the surface of the bone. For example **FIG. 14G(2)** illustrates a two peg set-up while **FIG. 14G(8)** illustrates a single peg scenario and **FIG. 14G(4)** illustrates a four peg scenario where some pegs are in parallel relationship while others are not. As shown in **FIG. 14G(9)**, the aperture (**1552 or 1553**) can be formed so that the bore does not form a cylinder, but rather has channel protrusions **1572** into the bone that, when filled, form the turning channel for a screw, thus resulting in the filled aperture forming a screw that enables the anchored device to be removed by turning in a clockwise or counter-clockwise direction.

[0202] As shown in **FIG. 14H**, a ridge **1546**, typically circumferential, can be used. The circumferential ridge can help achieve a tight seal between the detaining device and the cartilage in order to avoid spillage of the injected material in the joint cavity. Alternatively, the periphery of the mold can include a soft, compressible material that helps achieve a tight seal between the mold and the surrounding cartilage.

[0203] **FIG. 14I** illustrates the retaining mold with a handle placed on the surface of a bone.

[0204] As shown in **FIG. 14J**, the retaining device **1510** can have one or more handles **1547** attached to it. The handle can facilitate the surgeon maintaining the retaining device in position while the injected material hardens. The aperture **1512** of the retaining device accepts injections and can include a
5 membrane **1513** as shown in **FIG. 14J**. The configuration assists in creating a tight seal after a needle **1560** or injection instrument used to inject the material **1570** into the cavity **1520** is removed. Additionally, or in place of the membrane **1513**, a cap **1514** can be provided that seals the aperture **1512** after the material **1570** is injected. Additionally, anchoring teeth **1590** can be provided that
10 communicate with the meniscus **1591** or cartilage surrounding a defect. The anchoring teeth **1590** help keep the device stable when placed over the defect.

[0205] As illustrated in **FIG. 14G(4)** more than one aperture **1512, 1512'** can be provided without departing from the scope of the invention.

[0206] The retaining device system can be designed to inject an area equal
15 to or slightly greater than the area of diseased cartilage. Alternatively, the retaining device system can be designed for the entire weight-bearing surface or the entire articular surface of a compartment. Retaining devices can be used on opposing articular surfaces, *e.g.* on a femoral condyle and a tibial plateau, thereby recreating a smooth gliding surface on both articular surfaces.

[0207] The retaining device can be designed to allow for light exposure
20 including UV light. For example, the retaining device can be made using a transparent plastic. The retaining device can also be made to allow for passage of ultrasound waves.

[0208] C. CUSTOMIZED CONTAINERS

[0209] In another embodiment of the invention, a container or well can be
25 formed to the selected specifications, for example to match the material needed for a particular subject or to create a stock of repair materials in a variety of sizes. The size and shape of the container can be designed using the thickness and

curvature information obtained from the joint and from the cartilage defect. More specifically, the inside of the container can be shaped to follow any selected measurements, for example as obtained from the cartilage defect(s) of a particular subject. The container can be filled with a cartilage replacement or regenerating material, for example, collagen-containing materials, plastics, bioresorbable materials and/or any suitable tissue scaffold. The cartilage regenerating or replacement material can also consist of a suspension of stem cells or fetal or immature or mature cartilage cells that subsequently develop to more mature cartilage inside the container. Further, development and/or differentiation can be enhanced with use of certain tissue nutrients and growth factors.

[0210] The material is allowed to harden and/or grow inside the container until the material has the desired traits, for example, thickness, elasticity, hardness, biochemical composition, etc. Molds can be generated using any suitable technique, for example computer devices and automation, e.g. computer assisted design (CAD) and, for example, computer assisted modeling (CAM). Because the resulting material generally follows the contour of the inside of the container it will better fit the defect itself and facilitate integration.

[0211] D. DESIGNS ENCOMPASSING MULTIPLE COMPONENT REPAIR MATERIALS

[0212] The articular repair system or implants described herein can include one or more components.

[0213] FIGS. 15A-B shows single and multiple component devices. FIG. 15A illustrates an example of a single component articular surface repair system **1400** with varying curvature and radii that fits within the subchondral bone **1420** such that the interior surface **1402** of the system **1400** does not form an extension of the surface of the subchondral bone **1422**. The articular surface repair system is chosen to include convex **1402** and concave **1404** portions. Such devices can be preferable in a lateral femoral condyle or small joints such as the elbow joint.

FIG. 15B depicts a multi-component articular surface repair system with a second component 1410 with a surface 1412 that forms an extension of the surface 1422 of the subchondral bone 1420 and a first component 1405 with an interior surface 1406 that forms an extension of the curvature and shape of the surrounding normal cartilage 1415. The second component 1410 and the first component 1405 demonstrate varying curvatures and radii with convex and concave portions that correspond to the curvature of the subchondral bone 1420 and/or the normal cartilage 1415. As will be appreciated by those of skill in the art, these two components can be formed such that the parts are integrally formed with each other, or can be formed such that each part abuts the other. Additionally, the relationship between the parts can be by any suitable mechanism including adhesives and mechanical means.

[0214] FIGS. 16A-B show articular repair systems 100 having an outer contour 102 forming an extension of the surrounding normal cartilage 200. The systems are implanted into the underlying bone 300 using one or more pegs 150, 175. The pegs, pins, or screws can be porous-coated and can have flanges 125 as shown in FIG. 15B.

[0215] FIG. 17 shows an exemplary articular repair device 500 including a flat surface 510 to control depth and prevent toggle; an exterior surface 515 having the contour of normal cartilage; flanges 517 to prevent rotation and control toggle; a groove 520 to facilitate tissue in-growth.

[0216] FIGS. 18A-D depict, in cross-section, another example of an implant 640 with multiple anchoring pegs, stems, or screws 645. FIG. 18B-D show various cross-sectional representations of various possible embodiments of the pegs, or anchoring stems. FIG. 18B shows a peg 645 having a notch 646 or groove around its circumference; FIG. 18C shows a peg 645 with radially-extending arms 647 that help anchor the device in the underlying bone; and FIG. 18D shows a peg 645 with multiple grooves or flanges 648.

[0217] FIGS. 19A-B depict an overhead view of an exemplary implant 650 with multiple anchoring pegs 655 which illustrates that the pegs are not necessarily linearly aligned along the longitudinal axis of the device.

5 [0218] FIG. 20A depicts an implant 660 with a peg 661 having radially extending arms 665. FIGS. 20B-E are top views of the implant pegs illustrating a variety of suitable alternative shapes.

[0219] Examples of one-component systems include, but are not limited to, a plastic, a polymer, a metal, a metal alloy, crystal free metals, a biologic material or combinations thereof. In certain embodiments, the surface of the repair system
10 facing the underlying bone can be smooth. In other embodiments, the surface of the repair system facing the underlying bone can be porous or porous-coated. In another aspect, the surface of the repair system facing the underlying bone is designed with one or more grooves, for example to facilitate the in-growth of the surrounding tissue. The external surface of the device can have a step-like
15 design, which can be advantageous for altering biomechanical stresses. Optionally, flanges can also be added at one or more positions on the device (e.g., to prevent the repair system from rotating, to control toggle and/or prevent settling into the marrow cavity). The flanges can be part of a conical or a cylindrical design. A portion or all of the repair system facing the underlying bone
20 can also be flat which can help to control depth of the implant and to prevent toggle.

[0220] Non-limiting examples of multiple-component systems include combinations of metal, plastic, metal alloys, crystal free metals, and one or more biological materials. One or more components of the articular surface repair
25 system can be composed of a biologic material (e.g. a tissue scaffold with cells such as cartilage cells or stem cells alone or seeded within a substrate such as a bioresorbable material or a tissue scaffold, allograft, autograft or combinations thereof) and/or a non-biological material (e.g., polyethylene or a chromium alloy such as chromium cobalt).

[0221] Thus, the repair system can include one or more areas of a single material or a combination of materials, for example, the articular surface repair system can have a first and a second component. The first component is typically designed to have size, thickness and curvature similar to that of the cartilage tissue lost while the second component is typically designed to have a curvature similar to the subchondral bone. In addition, the first component can have biomechanical properties similar to articular cartilage, including but not limited to similar elasticity and resistance to axial loading or shear forces. The first and the second component can consist of two different metals or metal alloys. One or more components of the system (*e.g.*, the second portion) can be composed of a biologic material including, but not limited to bone, or a non-biologic material including, but not limited to hydroxyapatite, tantalum, a chromium alloy, chromium cobalt or other metal alloys.

[0222] One or more regions of the articular surface repair system (*e.g.*, the outer margin of the first portion and/or the second portion) can be bioresorbable, for example to allow the interface between the articular surface repair system and the patient's normal cartilage, over time, to be filled in with hyaline or fibrocartilage. Similarly, one or more regions (*e.g.*, the outer margin of the first portion of the articular surface repair system and/or the second portion) can be porous. The degree of porosity can change throughout the porous region, linearly or non-linearly, for where the degree of porosity will typically decrease towards the center of the articular surface repair system. The pores can be designed for in-growth of cartilage cells, cartilage matrix, and connective tissue thereby achieving a smooth interface between the articular surface repair system and the surrounding cartilage.

[0223] The repair system (*e.g.*, the second component in multiple component systems) can be attached to the patient's bone with use of a cement-like material such as methylmethacrylate, injectable hydroxy- or calcium-apatite materials and the like.

[0224] In certain embodiments, one or more portions of the articular surface repair system can be pliable or liquid or deformable at the time of implantation and can harden later. Hardening can occur, for example, within 1 second to 2 hours (or any time period therebetween), preferably within 1 second to 30 minutes (or any time period therebetween), more preferably between 1 second and 10 minutes (or any time period therebetween).

[0225] One or more components of the articular surface repair system can be adapted to receive injections. For example, the external surface of the articular surface repair system can have one or more openings therein. The openings can be sized to receive screws, tubing, needles or other devices which can be inserted and advanced to the desired depth, for example, through the articular surface repair system into the marrow space. Injectables such as methylmethacrylate and injectable hydroxy- or calcium-apatite materials can then be introduced through the opening (or tubing inserted therethrough) into the marrow space thereby bonding the articular surface repair system with the marrow space. Similarly, screws or pins, or other anchoring mechanisms, can be inserted into the openings and advanced to the underlying subchondral bone and the bone marrow or epiphysis to achieve fixation of the articular surface repair system to the bone. Portions or all components of the screw or pin can be bioresorbable, for example, the distal portion of a screw that protrudes into the marrow space can be bioresorbable. During the initial period after the surgery, the screw can provide the primary fixation of the articular surface repair system. Subsequently, ingrowth of bone into a porous coated area along the undersurface of the articular cartilage repair system can take over as the primary stabilizer of the articular surface repair system against the bone.

[0226] The articular surface repair system can be anchored to the patient's bone with use of a pin or screw or other attachment mechanism. The attachment mechanism can be bioresorbable. The screw or pin or attachment mechanism can be inserted and advanced towards the articular surface repair system from a

non-cartilage covered portion of the bone or from a non-weight-bearing surface of the joint.

[0227] The interface between the articular surface repair system and the surrounding normal cartilage can be at an angle, for example oriented at an angle of 90 degrees relative to the underlying subchondral bone. Suitable angles can be determined in view of the teachings herein, and in certain cases, non-90 degree angles can have advantages with regard to load distribution along the interface between the articular surface repair system and the surrounding normal cartilage.

[0228] The interface between the articular surface repair system and the surrounding normal cartilage and/or bone can be covered with a pharmaceutical or bioactive agent, for example a material that stimulates the biological integration of the repair system into the normal cartilage and/or bone. The surface area of the interface can be irregular, for example, to increase exposure of the interface to pharmaceutical or bioactive agents.

[0229] E. PRE-EXISTING REPAIR SYSTEMS

[0230] As described herein, repair systems, including surgical instruments, guides and molds, of various sizes, curvatures and thicknesses can be obtained. These repair systems, including surgical instruments, guides and molds, can be catalogued and stored to create a library of systems from which an appropriate system for an individual patient can then be selected. In other words, a defect, or an articular surface, is assessed in a particular subject and a pre-existing repair system, including surgical instruments, guides and molds, having a suitable shape and size is selected from the library for further manipulation (*e.g.*, shaping) and implantation.

[0231] F. MINI-PROSTHESIS

[0232] As noted above, the methods and compositions described herein can be used to replace only a portion of the articular surface, for example, an area

of diseased cartilage or lost cartilage on the articular surface. In these systems, the articular surface repair system can be designed to replace only the area of diseased or lost cartilage or it can extend beyond the area of diseased or lost cartilage, *e.g.*, 3 or 5 mm into normal adjacent cartilage. In certain embodiments, the prosthesis replaces less than about 70% to 80% (or any value therebetween) of the articular surface (*e.g.*, any given articular surface such as a single femoral condyle, etc.), preferably, less than about 50% to 70% (or any value therebetween), more preferably, less than about 30% to 50% (or any value therebetween), more preferably less than about 20% to 30% (or any value therebetween), even more preferably less than about 20% of the articular surface.

[0233] The prosthesis can include multiple components, for example a component that is implanted into the bone (*e.g.*, a metallic device) attached to a component that is shaped to cover the defect of the cartilage overlaying the bone. Additional components, for example intermediate plates, meniscal repair systems and the like can also be included. It is contemplated that each component replaces less than all of the corresponding articular surface. However, each component need not replace the same portion of the articular surface. In other words, the prosthesis can have a bone-implanted component that replaces less than 30% of the bone and a cartilage component that replaces 60% of the cartilage. The prosthesis can include any combination, provided each component replaces less than the entire articular surface.

[0234] The articular surface repair system can be formed or selected so that it will achieve a near anatomic fit or match with the surrounding or adjacent cartilage. Typically, the articular surface repair system is formed and/or selected so that its outer margin located at the external surface will be aligned with the surrounding or adjacent cartilage.

[0235] Thus, the articular repair system can be designed to replace the weight-bearing portion (or more or less than the weight bearing portion) of an articular surface, for example in a femoral condyle. The weight-bearing surface

refers to the contact area between two opposing articular surfaces during activities of normal daily living (e.g., normal gait). At least one or more weight-bearing portions can be replaced in this manner, e.g., on a femoral condyle and on a tibia.

5 **[0236]** In other embodiments, an area of diseased cartilage or cartilage loss can be identified in a weight-bearing area and only a portion of the weight-bearing area, specifically the portion containing the diseased cartilage or area of cartilage loss, can be replaced with an articular surface repair system.

[0237] In another embodiment, the articular repair system can be designed or selected to replace substantially all of the articular surface, e.g. a condyle.

10 **[0238]** In another embodiment, for example, in patients with diffuse cartilage loss, the articular repair system can be designed to replace an area slightly larger than the weight-bearing surface.

15 **[0239]** In certain aspects, the defect to be repaired is located only on one articular surface, typically the most diseased surface. For example, in a patient with severe cartilage loss in the medial femoral condyle but less severe disease in the tibia, the articular surface repair system can only be applied to the medial femoral condyle. Preferably, in any methods described herein, the articular surface repair system is designed to achieve an exact or a near anatomic fit with the adjacent normal cartilage.

20 **[0240]** In other embodiments, more than one articular surface can be repaired. The area(s) of repair will be typically limited to areas of diseased cartilage or cartilage loss or areas slightly greater than the area of diseased cartilage or cartilage loss within the weight-bearing surface(s).

25 **[0241]** The implant and/or the implant site can be sculpted to achieve a near anatomic alignment between the implant and the implant site. In another embodiment of the invention, an electronic image is used to measure the thickness, curvature, or shape of the articular cartilage or the subchondral bone, and/or the size of a defect, and an articular surface repair system is selected

using this information. The articular surface repair system can be inserted arthroscopically. The articular surface repair system can have a single radius. More typically, however, as shown in FIG. 15A, discussed above, the articular surface repair system **1500** has varying curvatures and radii within the same
5 plane, e.g. anteroposterior or mediolateral or superoinferior or oblique planes, or within multiple planes. In this manner, the articular surface repair system can be shaped to achieve a near anatomic alignment between the implant and the implant site. This design allows not only allows for different degrees of convexity or concavity, but also for concave portions within a predominantly convex shape
10 or vice versa **1500**.

[0242] In another embodiment the articular surface repair system has an anchoring stem, used to anchor the device, for example, as described in US Patent No. 6,224,632 to Pappas et al issued May 1, 2001. The stem, or peg, can have different shapes including conical, rectangular, fin among others. The mating
15 bone cavity is typically similarly shaped as the corresponding stem.

[0243] As shown in FIG. 16, discussed above, the articular surface repair system **100** can be affixed to the subchondral bone **300**, with one or more stems, or pegs, **150** extending through the subchondral plate into the marrow space. In certain instances, this design can reduce the likelihood that the implant will settle
20 deeper into the joint over time by resting portions of the implant against the subchondral bone. The stems, or pegs, can be of any shape suitable to perform the function of anchoring the device to the bone. For example, the pegs can be cylindrical or conical. Optionally, the stems, or pegs, can further include notches or openings to allow bone in-growth. In addition, the stems can be porous coated
25 for bone in-growth. The anchoring stems or pegs can be affixed to the bone using bone cement. An additional anchoring device can also be affixed to the stem or peg. The anchoring device can have an umbrella shape (e.g., radially expanding elements) with the wider portion pointing towards the subchondral bone and away from the peg. The anchoring device can be advantageous for providing

immediate fixation of the implant. The undersurface of the articular repair system facing the subchondral bone can be textured or rough thereby increasing the contact surface between the articular repair system and the subchondral bone. Alternatively, the undersurface of the articular repair system can be porous coated
5 thereby allowing in-growth. The surgeon can support the in-growth of bone by treating the subchondral bone with a rasp, typically to create a larger surface area and/or until bleeding from the subchondral bone occurs.

[0244] In another embodiment, the articular surface repair system can be attached to the underlying bone or bone marrow using bone cement. Bone
10 cement is typically made from an acrylic polymeric material. Typically, the bone cement is comprised of two components: a dry powder component and a liquid component, which are subsequently mixed together. The dry component generally includes an acrylic polymer, such as polymethylmethacrylate (PMMA). The dry component can also contain a polymerization initiator such as benzoylperoxide,
15 which initiates the free-radical polymerization process that occurs when the bone cement is formed. The liquid component, on the other hand, generally contains a liquid monomer such as methyl methacrylate (MMA). The liquid component can also contain an accelerator such as an amine (e.g., N,N-dimethyl-p-toluidine). A stabilizer, such as hydroquinone, can also be added to the liquid component to
20 prevent premature polymerization of the liquid monomer. When the liquid component is mixed with the dry component, the dry component begins to dissolve or swell in the liquid monomer. The amine accelerator reacts with the initiator to form free radicals that begin to link monomer units to form polymer chains. In the next two to four minutes, the polymerization process proceeds
25 changing the viscosity of the mixture from a syrup-like consistency (low viscosity) into a dough-like consistency (high viscosity). Ultimately, further polymerization and curing occur, causing the cement to harden and affix a prosthesis to a bone.

[0245] In certain aspects of the invention, as shown in **FIG. 7E**, above, bone cement **755** or another liquid attachment material such as injectable

calciumhydroxyapatite can be injected into the marrow cavity through one or more openings **750** in the prosthesis. These openings in the prosthesis can extend from the articular surface to the undersurface of the prosthesis **760**. After injection, the openings can be closed with a polymer, silicon, metal, metal alloy or bioresorbable
5 plug.

[0246] In another embodiment, one or more components of the articular surface repair (*e.g.*, the surface of the system that is pointing towards the underlying bone or bone marrow) can be porous or porous coated. A variety of different porous metal coatings have been proposed for enhancing fixation of a
10 metallic prosthesis by bone tissue in-growth. Thus, for example, U.S. Pat. No. 3,855,638 to Pilliar issued December 24, 2974, discloses a surgical prosthetic device, which can be used as a bone prosthesis, comprising a composite structure consisting of a solid metallic material substrate and a porous coating of the same solid metallic material adhered to and extending over at least a portion
15 of the surface of the substrate. The porous coating consists of a plurality of small discrete particles of metallic material bonded together at their points of contact with each other to define a plurality of connected interstitial pores in the coating. The size and spacing of the particles, which can be distributed in a plurality of monolayers, can be such that the average interstitial pore size is not more than
20 about 200 microns. Additionally, the pore size distribution can be substantially uniform from the substrate-coating interface to the surface of the coating. In another embodiment, the articular surface repair system can contain one or more polymeric materials that can be loaded with and release therapeutic agents including drugs or other pharmacological treatments that can be used for drug
25 delivery. The polymeric materials can, for example, be placed inside areas of porous coating. The polymeric materials can be used to release therapeutic drugs, *e.g.* bone or cartilage growth stimulating drugs. This embodiment can be combined with other embodiments, wherein portions of the articular surface repair system can be bioresorbable. For example, the first layer of an articular surface

repair system or portions of its first layer can be bioresorbable. As the first layer gets increasingly resorbed, local release of a cartilage growth-stimulating drug can facilitate in-growth of cartilage cells and matrix formation.

5 **[0247]** In any of the methods or compositions described herein, the articular surface repair system can be pre-manufactured with a range of sizes, curvatures and thicknesses. Alternatively, the articular surface repair system can be custom-made for an individual patient.

[0248] IV. MANUFACTURING

[0249] A. SHAPING

10 **[0250]** In certain instances shaping of the repair material will be required before or after formation (*e.g.*, growth to desired thickness), for example where the thickness of the required cartilage material is not uniform (*e.g.*, where different sections of the cartilage replacement or regenerating material require different thicknesses).

15 **[0251]** The replacement material can be shaped by any suitable technique including, but not limited to, mechanical abrasion, laser abrasion or ablation, radiofrequency treatment, cryoablation, variations in exposure time and concentration of nutrients, enzymes or growth factors and any other means suitable for influencing or changing cartilage thickness. See, *e.g.*, WO 00/15153
20 to Mansmann published March 23, 2000; If enzymatic digestion is used, certain sections of the cartilage replacement or regenerating material can be exposed to higher doses of the enzyme or can be exposed longer as a means of achieving different thicknesses and curvatures of the cartilage replacement or regenerating material in different sections of said material.

25 **[0252]** The material can be shaped manually and/or automatically, for example using a device into which a pre-selected thickness and/or curvature has been input and then programming the device using the input information to achieve the desired shape.

[0253] In addition to, or instead of, shaping the cartilage repair material, the site of implantation (*e.g.*, bone surface, any cartilage material remaining, etc.) can also be shaped by any suitable technique in order to enhance integration of the repair material.

5 **[0254] B. SIZING**

[0255] The articular repair system can be formed or selected so that it will achieve a near anatomic fit or match with the surrounding or adjacent cartilage or subchondral bone or menisci and other tissue. The shape of the repair system can be based on the analysis of an electronic image (*e.g.* MRI, CT, digital
10 tomosynthesis, optical coherence tomography or the like). If the articular repair system is intended to replace an area of diseased cartilage or lost cartilage, the near anatomic fit can be achieved using a method that provides a virtual reconstruction of the shape of healthy cartilage in an electronic image.

[0256] In one embodiment of the invention, a near normal cartilage surface
15 at the position of the cartilage defect can be reconstructed by interpolating the healthy cartilage surface across the cartilage defect or area of diseased cartilage. This can, for example, be achieved by describing the healthy cartilage by means of a parametric surface (*e.g.* a B-spline surface), for which the control points are placed such that the parametric surface follows the contour of the healthy
20 cartilage and bridges the cartilage defect or area of diseased cartilage. The continuity properties of the parametric surface will provide a smooth integration of the part that bridges the cartilage defect or area of diseased cartilage with the contour of the surrounding healthy cartilage. The part of the parametric surface over the area of the cartilage defect or area of diseased cartilage can be used to
25 determine the shape or part of the shape of the articular repair system to match with the surrounding cartilage.

[0257] In another embodiment, a near normal cartilage surface at the position of the cartilage defect or area of diseased cartilage can be reconstructed

using morphological image processing. In a first step, the cartilage can be extracted from the electronic image using manual, semi-automated and/or automated segmentation techniques (*e.g.*, manual tracing, region growing, live wire, model-based segmentation), resulting in a binary image. Defects in the cartilage appear as indentations that can be filled with a morphological closing operation performed in 2-D or 3-D with an appropriately selected structuring element. The closing operation is typically defined as a dilation followed by an erosion. A dilation operator sets the current pixel in the output image to 1 if at least one pixel of the structuring element lies inside a region in the source image. An erosion operator sets the current pixel in the output image to 1 if the whole structuring element lies inside a region in the source image. The filling of the cartilage defect or area of diseased cartilage creates a new surface over the area of the cartilage defect or area of diseased cartilage that can be used to determine the shape or part of the shape of the articular repair system to match with the surrounding cartilage or subchondral bone.

[0258] As described above, the articular repair system, including surgical tools and instruments, molds, *in situ* repair systems, etc. can be formed or selected from a library or database of systems of various sizes, curvatures and thicknesses so that it will achieve a near anatomic fit or match with the surrounding or adjacent cartilage and/or subchondral bone. These systems can be pre-made or made to order for an individual patient. In order to control the fit or match of the articular repair system with the surrounding or adjacent cartilage or subchondral bone or menisci and other tissues preoperatively, a software program can be used that projects the articular repair system over the anatomic position where it will be implanted. Suitable software is commercially available and/or readily modified or designed by a skilled programmer.

[0259] In yet another embodiment, the articular surface repair system can be projected over the implantation site using one or more 3-D images. The cartilage and/or subchondral bone and other anatomic structures are extracted

from a 3-D electronic image such as an MRI or a CT using manual, semi-automated and/or automated segmentation techniques. A 3-D representation of the cartilage and/or subchondral bone and other anatomic structures as well as the articular repair system is generated, for example using a polygon or NURBS surface or other parametric surface representation. For a description of various parametric surface representations see, for example Foley, J.D. et al., Computer Graphics: Principles and Practice in C; Addison-Wesley, 2nd edition, 1995).

[0260] The 3-D representations of the cartilage and/or subchondral bone and other anatomic structures and the articular repair system can be merged into a common coordinate system. The articular repair system, including surgical tools and instruments, molds, *in situ* repair systems, etc. can then be placed at the desired implantation site. The representations of the cartilage, subchondral bone, menisci and other anatomic structures and the articular repair system are rendered into a 3-D image, for example application programming interfaces (APIs) OpenGL® (standard library of advanced 3-D graphics functions developed by SGI, Inc.; available as part of the drivers for PC-based video cards, for example from www.nvidia.com for NVIDIA video cards or www.3dlabs.com for 3Dlabs products, or as part of the system software for Unix workstations) or DirectX® (multimedia API for Microsoft Windows® based PC systems; available from www.microsoft.com). The 3-D image can be rendered showing the cartilage, subchondral bone, menisci or other anatomic objects, and the articular repair system from varying angles, *e.g.* by rotating or moving them interactively or non-interactively, in real-time or non-real-time.

[0261] The software can be designed so that the articular repair system, including surgical tools and instruments, molds, *in situ* repair systems, etc. with the best fit relative to the cartilage and/or subchondral bone is automatically selected, for example using some of the techniques described above. Alternatively, the operator can select an articular repair system, including surgical tools and instruments, molds, *in situ* repair systems, etc. and project it or drag it

5 onto the implantation site using suitable tools and techniques. The operator can move and rotate the articular repair systems in three dimensions relative to the implantation site and can perform a visual inspection of the fit between the articular repair system and the implantation site. The visual inspection can be computer assisted. The procedure can be repeated until a satisfactory fit has been achieved. The procedure can be performed manually by the operator; or it can be computer-assisted in whole or part. For example, the software can select a first trial implant that the operator can test. The operator can evaluate the fit. The software can be designed and used to highlight areas of poor alignment
10 between the implant and the surrounding cartilage or subchondral bone or menisci or other tissues. Based on this information, the software or the operator can then select another implant and test its alignment. One of skill in the art will readily be able to select, modify and/or create suitable computer programs for the purposes described herein.

15 **[0262]** In another embodiment, the implantation site can be visualized using one or more cross-sectional 2-D images. Typically, a series of 2-D cross-sectional images will be used. The 2-D images can be generated with imaging tests such as CT, MRI, digital tomosynthesis, ultrasound, or optical coherence tomography using methods and tools known to those of skill in the art. The articular repair system, including surgical tools and instruments, molds, *in situ*
20 repair systems, etc. can then be superimposed onto one or more of these 2-D images. The 2-D cross-sectional images can be reconstructed in other planes, e.g. from sagittal to coronal, etc. Isotropic data sets (e.g., data sets where the slice thickness is the same or nearly the same as the in-plane resolution) or near isotropic data sets can also be used. Multiple planes can be displayed
25 simultaneously, for example using a split screen display. The operator can also scroll through the 2-D images in any desired orientation in real time or near real time; the operator can rotate the imaged tissue volume while doing this. The articular repair system, including surgical tools and instruments, molds, *in situ*

repair systems, etc. can be displayed in cross-section utilizing different display planes, e.g. sagittal, coronal or axial, typically matching those of the 2-D images demonstrating the cartilage, subchondral bone, menisci or other tissue.

Alternatively, a three-dimensional display can be used for the articular repair system. The 2-D electronic image and the 2-D or 3-D representation of the articular repair system, including surgical tools and instruments, molds, *in situ* repair systems, etc. can be merged into a common coordinate system. The articular repair system can then be placed at the desired implantation site. The series of 2-D cross-sections of the anatomic structures, the implantation site and the articular repair system can be displayed interactively (e.g. the operator can scroll through a series of slices) or non-interactively (e.g. as an animation that moves through the series of slices), in real-time or non-real-time.

[0263] The software can be designed so that the articular repair system, including surgical tools and instruments, molds, *in situ* repair systems, etc. with the best fit relative to the cartilage and/or subchondral bone is automatically selected, for example using one or more of the techniques described above. Alternatively, the operator can select an articular repair system, including surgical tools and instruments, molds, *in situ* repair systems, etc. and project it or drag it onto the implantation site displayed on the cross-sectional 2-D images. The operator can then move and rotate the articular repair system relative to the implantation site and scroll through a cross-sectional 2-D display of the articular repair system and of the anatomic structures. The operator can perform a visual and/or computer-assisted inspection of the fit between the articular repair system and the implantation site. The procedure can be repeated until a satisfactory fit has been achieved. The procedure can be entirely manual by the operator; it can, however, also be computer-assisted. For example, the software can select a first trial implant that the operator can test (e.g., evaluate the fit). Software that highlights areas of poor alignment between the implant and the surrounding cartilage or subchondral bone or menisci or other tissues can also be designed

and used. Based on this information, the software or the operator can select another implant and test its alignment.

[0264] C. RAPID PROTOTYPING

[0265] Rapid prototyping is a technique for fabricating a three-dimensional object from a computer model of the object. A special printer is used to fabricate the prototype from a plurality of two-dimensional layers. Computer software sections the representations of the object into a plurality of distinct two-dimensional layers and then a three-dimensional printer fabricates a layer of material for each layer sectioned by the software. Together the various fabricated layers form the desired prototype. More information about rapid prototyping techniques is available in US Patent Publication No 2002/0079601A1 to Russell et al., published June 27, 2002. An advantage to using rapid prototyping is that it enables the use of free form fabrication techniques that use toxic or potent compounds safely. These compounds can be safely incorporated in an excipient envelope, which reduces worker exposure

[0266] A powder piston and build bed are provided. Powder includes any material (metal, plastic, etc.) that can be made into a powder or bonded with a liquid. The powder is rolled from a feeder source with a spreader onto a surface of a bed. The thickness of the layer is controlled by the computer. The print head then deposits a binder fluid onto the powder layer at a location where it is desired that the powder bind. Powder is again rolled into the build bed and the process is repeated, with the binding fluid deposition being controlled at each layer to correspond to the three-dimensional location of the device formation. For a further discussion of this process see, for example, US Patent Publication No 2003/017365A1 to Monkhouse et al. published September 18, 2003.

[0267] The rapid prototyping can use the two dimensional images obtained, as described above in Section I, to determine each of the two-dimensional shapes for each of the layers of the prototyping machine. In this scenario, each two

dimensional image slice would correspond to a two dimensional prototype slide. Alternatively, the three-dimensional shape of the defect can be determined, as described above, and then broken down into two dimensional slices for the rapid prototyping process. The advantage of using the three-dimensional model is that the two-dimensional slices used for the rapid prototyping machine can be along the same plane as the two-dimensional images taken or along a different plane altogether.

[0268] Rapid prototyping can be combined or used in conjunction with casting techniques. For example, a shell or container with inner dimensions corresponding to an articular repair system including surgical instruments, molds, alignment guides or surgical guides, can be made using rapid prototyping. Plastic or wax-like materials are typically used for this purpose. The inside of the container can subsequently be coated, for example with a ceramic, for subsequent casting. Using this process, personalized casts can be generated.

[0269] Rapid prototyping can be used for producing articular repair systems including surgical tools, molds, alignment guides, cut guides etc. Rapid prototyping can be performed at a manufacturing facility. Alternatively, it may be performed in the operating room after an intraoperative measurement has been performed.

[0270] **III. IMPLANTATION**

[0271] Following one or more manipulations (*e.g.*, shaping, growth, development, etc), the cartilage replacement or regenerating material can then be implanted into the area of the defect. Implantation can be performed with the cartilage replacement or regenerating material still attached to the base material or removed from the base material. Any suitable methods and devices can be used for implantation, for example, devices as described in U.S. Patent Nos. 6,375,658 to Hangody et al. issued April 23, 2002; 6,358,253 to Torrie et al. issued March 19, 2002; 6,328,765 to Hardwick et al. issued December 11, 2001;

and International Publication WO 01/19254 to Cummings et al. published March 22, 2001.

[0272] In selected cartilage defects, the implantation site can be prepared with a single cut across the articular surface, for example, as shown in FIG. 8. In
5 this case, single **810** and multi-component **820** prostheses can be utilized.

[0273] A. THE JOINT REPLACEMENT PROCEDURE

[0274] i. Knee Joint

[0275] Performing a total knee arthroplasty is a complicated procedure. In replacing the knee with an artificial knee, it is important to get the anatomical and
10 mechanical axes of the lower extremity aligned correctly to ensure optimal functioning of the implanted knee.

[0276] As shown in FIG. 21A, the center of the hip **1902** (located at the head **1930** of the femur **1932**), the center of the knee **1904** (located at the notch where the intercondylar tubercle **1934** of the tibia **1936** meet the femur) and ankle **1906**
15 lie approximately in a straight line **1910** which defines the mechanical axis of the lower extremity. The anatomic axis **1920** aligns 5-7° offset θ from the mechanical axis in the valgus, or outward, direction.

[0277] The long axis of the tibia **1936** is collinear with the mechanical axis of the lower extremity **1910**. From a three-dimensional perspective, the lower
20 extremity of the body ideally functions within a single plane known as the median anterior-posterior plane (MAP-plane) throughout the flexion-extension arc. In order to accomplish this, the femoral head **1930**, the mechanical axis of the femur, the patellar groove, the intercondylar notch, the patellar articular crest, the tibia and the ankle remain within the MAP-plane during the flexion-extension movement.
25 During movement, the tibia rotates as the knee flexes and extends in the epicondylar axis which is perpendicular to the MAP-plane.

[0278] A variety of image slices can be taken at each individual joint, e.g., the knee joint **1950-1950_n**, and the hip joint **1952-1950_n**. These image slices can be used as described above in Section I along with an image of the full leg to ascertain the axis.

5 **[0279]** With disease and malfunction of the knee, alignment of the anatomic axis is altered. Performing a total knee arthroplasty is one solution for correcting a diseased knee. Implanting a total knee joint, such as the PFC Sigma RP Knee System by Johnson & Johnson, requires that a series of resections be made to the surfaces forming the knee joint in order to facilitate installation of the artificial
10 knee. The resections should be made to enable the installed artificial knee to achieve flexion-extension movement within the MAP-plane and to optimize the patient's anatomical and mechanical axis of the lower extremity.

[0280] First, the tibia **1930** is resected to create a flat surface to accept the tibial component of the implant. In most cases, the tibial surface is resected
15 perpendicular to the long axis of the tibia in the coronal plane, but is typically sloped 4-7° posteriorly in the sagittal plane to match the normal slope of the tibia. As will be appreciated by those of skill in the art, the sagittal slope can be 0° where the device to be implanted does not require a sloped tibial cut. The resection line **1958** is perpendicular to the mechanical axis **1910**, but the angle
20 between the resection line and the surface plane of the plateau **1960** varies depending on the amount of damage to the knee.

[0281] **FIGS. 21B-D** illustrate an anterior view of a resection of an anatomically normal tibial component, a tibial component in a varus knee, and a tibial component in a valgus knee, respectively. In each figure, the mechanical
25 axis **1910** extends vertically through the bone and the resection line **1958** is perpendicular to the mechanical axis **1910** in the coronal plane, varying from the surface line formed by the joint depending on the amount of damage to the joint. **FIG. 21B** illustrates a normal knee wherein the line corresponding to the surface of

the joint **1960** is parallel to the resection line **1958**. FIG. 21c illustrates a varus knee wherein the line corresponding to the surface of the joint **1960** is not parallel to the resection line **1958**. FIG. 21D illustrates a valgus knee wherein the line corresponding to the surface of the joint **1960** is not parallel to the resection line **1958**.

5

[0282] Once the tibial surface has been prepared, the surgeon turns to preparing the femoral condyle.

[0283] The plateau of the femur **1970** is resected to provide flat surfaces that communicate with the interior of the femoral prosthesis. The cuts made to the femur are based on the overall height of the gap to be created between the tibia and the femur. Typically, a 20 mm gap is desirable to provide the implanted prosthesis adequate room to achieve full range of motion. The bone is resected at a 5-7° angle valgus to the mechanical axis of the femur. Resected surface **1972** forms a flat plane with an angular relationship to adjoining surfaces **1974**, **1976**.

10

The angle θ' , θ'' between the surfaces **1972-1974**, and **1972-1976** varies according to the design of the implant.

15

[0284] ii. Hip Joint

[0285] As illustrated in FIG. 21F, the external geometry of the proximal femur includes the head **1980**, the neck **1982**, the lesser trochanter **1984**, the greater trochanter **1986** and the proximal femoral diaphysis. The relative positions of the trochanters **1984**, **1986**, the femoral head center **1902** and the femoral shaft **1988** are correlated with the inclination of the neck-shaft angle. The mechanical axis **1910** and anatomic axis **1920** are also shown. Assessment of these relationships can change the reaming direction to achieve neutral alignment of the prosthesis with the femoral canal.

20

25

[0286] Using anteroposterior and lateral radiographs, measurements are made of the proximal and distal geometry to determine the size and optimal design of the implant.

[0287] Typically, after obtaining surgical access to the hip joint, the femoral neck **1982** is resected, *e.g.* along the line **1990**. Once the neck is resected, the medullary canal is reamed. Reaming can be accomplished, for example, with a conical or straight reamer, or a flexible reamer. The depth of reaming is dictated
5 by the specific design of the implant. Once the canal has been reamed, the proximal reamer is prepared by serial rasping, with the rasp directed down into the canal.

[0288] B. SURGICAL TOOLS

[0289] Further, surgical assistance can be provided by using a device
10 applied to the outer surface of the articular cartilage or the bone, including the subchondral bone, in order to match the alignment of the articular repair system and the recipient site or the joint. The device can be round, circular, oval, ellipsoid, curved or irregular in shape. The shape can be selected or adjusted to match or enclose an area of diseased cartilage or an area slightly larger than the
15 area of diseased cartilage or substantially larger than the diseased cartilage. The area can encompass the entire articular surface or the weight bearing surface. Such devices are typically preferred when replacement of a majority or an entire articular surface is contemplated.

[0290] Mechanical devices can be used for surgical assistance (*e.g.*,
20 surgical tools), for example using gels, molds, plastics or metal. One or more electronic images or intraoperative measurements can be obtained providing object coordinates that define the articular and/or bone surface and shape. These objects' coordinates can be utilized to either shape the device, *e.g.* using a CAD/CAM technique, to be adapted to a patient's articular anatomy or,
25 alternatively, to select a typically pre-made device that has a good fit with a patient's articular anatomy. The device can have a surface and shape that will match all or portions of the articular or bone surface and shape, *e.g.* similar to a "mirror image." The device can include apertures, slots and/or holes to

accommodate surgical instruments such as drills, reamers, curettes, k-wires, screws and saws.

[0291] Typically, a position will be chosen that will result in an anatomically desirable cut plane, drill hole, or general instrument orientation for subsequent placement of an articular repair system or for facilitating placement of the articular repair system. Moreover, the device can be designed so that the depth of the drill, reamer or other surgical instrument can be controlled, *e.g.*, the drill cannot go any deeper into the tissue than defined by the device, and the size of the hole in the block can be designed to essentially match the size of the implant. Information about other joints or axis and alignment information of a joint or extremity can be included when selecting the position of these slots or holes. Alternatively, the openings in the device can be made larger than needed to accommodate these instruments. The device can also be configured to conform to the articular shape. The apertures, or openings, provided can be wide enough to allow for varying the position or angle of the surgical instrument, *e.g.*, reamers, saws, drills, curettes and other surgical instruments. An instrument guide, typically comprised of a relatively hard material, can then be applied to the device. The device helps orient the instrument guide relative to the three-dimensional anatomy of the joint.

[0292] The surgeon can, optionally, make fine adjustments between the alignment device and the instrument guide. In this manner, an optimal compromise can be found, for example, between biomechanical alignment and joint laxity or biomechanical alignment and joint function, *e.g.* in a knee joint flexion gap and extension gap. By oversizing the openings in the alignment guide, the surgeon can utilize the instruments and insert them in the instrument guide without damaging the alignment guide. Thus, in particular if the alignment guide is made of plastic, debris will not be introduced into the joint. The position and orientation between the alignment guide and the instrument guide can be also be optimized with the use of, for example, interposed spacers, wedges, screws and other mechanical or electrical methods known in the art.

[0293] A surgeon may desire to influence joint laxity as well as joint alignment. This can be optimized for different flexion and extension, abduction, or adduction, internal and external rotation angles. For this purpose, for example, spacers can be introduced that are attached or that are in contact with one or more molds. The surgeon can intraoperatively evaluate the laxity or tightness of a joint using spacers with different thickness or one or more spacers with the same thickness. For example, spacers can be applied in a knee joint in the presence of one or more molds and the flexion gap can be evaluated with the knee joint in flexion. The knee joint can then be extended and the extension gap can be evaluated. Ultimately, the surgeon will select an optimal combination of spacers for a given joint and mold. A surgical cut guide can be applied to the mold with the spacers optionally interposed between the mold and the cut guide. In this manner, the exact position of the surgical cuts can be influenced and can be adjusted to achieve an optimal result. Someone skilled in the art will recognize other means for optimizing the position of the surgical cuts. For example, expandable or ratchet-like devices can be utilized that can be inserted into the joint or that can be attached or that can touch the mold. Hinge-like mechanisms are applicable. Similarly, jack-like mechanisms are useful. In principal, any mechanical or electrical device useful for fine-tuning the position of the cut guide relative to the molds can be used.

[0294] A surgeon may desire to influence joint laxity as well as joint alignment. This can be optimized for different flexion and extension, abduction, or adduction, internal and external rotation angles. For this purpose, for example, spacers can be introduced that are attached or that are in contact with one or more molds. The surgeon can intraoperatively evaluate the laxity or tightness of a joint using spacers with different thickness or one or more spacers with the same thickness. For example, spacers can be applied in a knee joint in the presence of one or more molds and the flexion gap can be evaluated with the knee joint in flexion. The knee joint can then be extended and the extension gap can be

evaluated. Ultimately, the surgeon will select an optimal combination of spacers for a given joint and mold. A surgical cut guide can be applied to the mold with the spacers optionally interposed between the mold and the cut guide. In this manner, the exact position of the surgical cuts can be influenced and can be
5 adjusted to achieve an optimal result. Someone skilled in the art will recognize other means for optimizing the position of the surgical cuts. For example, expandable or ratchet-like devices can be utilized that can be inserted into the joint or that can be attached or that can touch the mold. Hinge-like mechanisms are applicable. Similarly, jack-like mechanisms are useful. In principal, any
10 mechanical or electrical device useful for fine-tuning the position of the cut guide relative to the molds can be used.

[0295] The molds and any related instrumentation such as spacers or ratchets can be combined with a tensiometer to provide a better intraoperative assessment of the joint. The tensiometer can be utilized to further optimize the
15 anatomic alignment and tightness of the joint and to improve post-operative function and outcomes. Optionally local contact pressures may be evaluated intraoperatively, for example using a sensor like the ones manufactured by Tekscan, South Boston, Massachusetts.

[0296] The mold or alignment guide can be made of a plastic or polymer.
20 In other embodiments, the mold or portions of the mold can be made of metal. Metal inserts may be applied to plastic components. For example, a plastic mold may have an opening to accept a reaming device or a saw. A metal insert may be used to provide a hard wall to accept the reamer or saw. Using this or similar designs can be useful to avoid the accumulation of plastic or other debris in the
25 joint when the saw or other surgical instruments may get in contact with the mold.

[0297] The molds may not only be used for assisting the surgical technique and guiding the placement and direction of surgical instruments. In addition, the molds can be utilized for guiding the placement of the implant or implant components. For example, in the hip joint, tilting of the acetabular component is a

frequent problem with total hip arthroplasty. A mold can be applied to the acetabular wall with an opening in the center large enough to accommodate the acetabular component that the surgeon intends to place. The mold can have receptacles or notches that match the shape of small extensions that can be part of the implant or that can be applied to the implant. For example, the implant can have small members or extensions applied to the twelve o'clock and six o'clock positions. See, for example, **FIG. 29A-D**, discussed below. By aligning these members with notches or receptacles in the mold, the surgeon can ensure that the implant is inserted without tilting or rotation. These notches or receptacles can also be helpful to hold the implant in place while bone cement is hardening in cemented designs.

[0298] One or more molds can be used during the surgery. For example, in the hip, a mold can be initially applied to the proximal femur that closely approximates the 3D anatomy prior to the resection of the femoral head. The mold can include an opening to accommodate a saw (see **FIGS. 28-29**). The opening is positioned to achieve an optimally placed surgical cut for subsequent reaming and placement of the prosthesis. A second mold can then be applied to the proximal femur after the surgical cut has been made. The second mold can be useful for guiding the direction of a reamer prior to placement of the prosthesis. As can be seen in this, as well as in other examples, molds can be made for joints prior to any surgical intervention. However, it is also possible to make molds that are designed to fit to a bone or portions of a joint after the surgeon has already performed selected surgical procedures, such as cutting, reaming, drilling, etc. The mold can account for the shape of the bone or the joint resulting from these procedures.

[0299] In certain embodiments, the surgical assistance device comprises an array of adjustable, closely spaced pins (*e.g.*, plurality of individually moveable mechanical elements). One or more electronic images or intraoperative measurements can be obtained providing object coordinates that define the

articular and/or bone surface and shape. These objects' coordinates can be entered or transferred into the device, for example manually or electronically, and the information can be used to create a surface and shape that will match all or portions of the articular and/or bone surface and shape by moving one or more of the elements, e.g. similar to an "image." The device can include slots and holes to accommodate surgical instruments such as drills, curettes, k-wires, screws and saws. The position of these slots and holes can be adjusted by moving one or more of the mechanical elements. Typically, a position will be chosen that will result in an anatomically desirable cut plane, reaming direction, or drill hole or instrument orientation for subsequent placement of an articular repair system or for facilitating the placement of an articular repair system. Information about other joints or axis and alignment information of a joint or extremity can be included when selecting the position of these slots or holes.

[0300] FIG. 22 shows an example of a surgical tool **410** having one surface **400** matching the geometry of an articular surface of the joint. Also shown is an aperture **415** in the tool **410** capable of controlling drill depth and width of the hole and allowing implantation or insertion of implant **420** having a press-fit design.

[0301] In another embodiment, a frame can be applied to the bone or the cartilage in areas other than the diseased bone or cartilage. The frame can include holders and guides for surgical instruments. The frame can be attached to one or preferably more previously defined anatomic reference points. Alternatively, the position of the frame can be cross-registered relative to one, or more, anatomic landmarks, using an imaging test or intraoperative measurement, for example one or more fluoroscopic images acquired intraoperatively. One or more electronic images or intraoperative measurements including using mechanical devices can be obtained providing object coordinates that define the articular and/or bone surface and shape. These objects' coordinates can be entered or transferred into the device, for example manually or electronically, and the information can be used to move one or more of the holders or guides for

surgical instruments. Typically, a position will be chosen that will result in a surgically or anatomically desirable cut plane or drill hole orientation for subsequent placement of an articular repair system. Information about other joints or axis and alignment information of a joint or extremity can be included when
5 selecting the position of these slots or holes.

[0302] Furthermore, re-useable tools (*e.g.*, molds) can be also be created and employed. Non-limiting examples of re-useable materials include putties and other deformable materials (*e.g.*, an array of adjustable closely spaced pins that can be configured to match the topography of a joint surface). In other
10 embodiments, the molds may be made using balloons. The balloons can optionally be filled with a hardening material. A surface can be created or can be incorporated in the balloon that allows for placement of a surgical cut guide, reaming guide, drill guide or placement of other surgical tools. The balloon or other deformable material can be shaped intraoperatively to conform to at least
15 one articular surface. Other surfaces can be shaped in order to be parallel or perpendicular to anatomic or biomechanical axes. The anatomic or biomechanical axes can be found using an intraoperative imaging test or surgical tools commonly used for this purpose in hip, knee or other arthroplasties.

[0303] In these embodiments, the mold can be created directly from the
20 joint during surgery or, alternatively, created from an image of the joint, for example, using one or more computer programs to determine object coordinates defining the surface contour of the joint and transferring (*e.g.*, dialing-in) these coordinates to the tool. Subsequently, the tool can be aligned accurately over the joint and, accordingly, the surgical instrument guide or the implant will be more
25 accurately placed in or over the articular surface.

[0304] In both single-use and re-useable embodiments, the tool can be designed so that the instrument controls the depth and/or direction of the drill, *i.e.*, the drill cannot go any deeper into the tissue than the instrument allows, and the size of the hole or aperture in the instrument can be designed to essentially match

the size of the implant. The tool can be used for general prosthesis implantation, including, but not limited to, the articular repair implants described herein and for reaming the marrow in the case of a total arthroplasty.

- 5 **[0305]** These surgical tools (devices) can also be used to remove an area of diseased cartilage and underlying bone or an area slightly larger than the diseased cartilage and underlying bone. In addition, the device can be used on a "donor," *e.g.*, a cadaveric specimen, to obtain implantable repair material. The device is typically positioned in the same general anatomic area in which the tissue was removed in the recipient. The shape of the device is then used to
- 10 identify a donor site providing a seamless or near seamless match between the donor tissue sample and the recipient site. This can be achieved by identifying the position of the device in which the articular surface in the donor, *e.g.* a cadaveric specimen, has a seamless or near seamless contact with the inner surface when applied to the cartilage.
- 15 **[0306]** The device can be molded, machined or formed based on the size of the area of diseased cartilage and based on the curvature of the cartilage or the underlying subchondral bone or a combination of both. The molding can take into consideration surgical removal of, for example, the meniscus, in arriving at a joint surface configuration. The device can then be applied to the donor, (*e.g.*, a
- 20 cadaveric specimen) and the donor tissue can be obtained with use of a blade or saw or other tissue removing device. The device can then be applied to the recipient in the area of the diseased cartilage and the diseased cartilage and underlying bone can be removed with use of a blade or saw or other tissue cutting device whereby the size and shape of the removed tissue containing the diseased
- 25 cartilage will closely resemble the size and shape of the donor tissue. The donor tissue can then be attached to the recipient site. For example, said attachment can be achieved with use of screws or pins (*e.g.*, metallic, non-metallic or bioresorbable) or other fixation means including but not limited to a tissue adhesive.

Attachment can be through the cartilage surface or alternatively, through the marrow space.

[0307] The implant site can be prepared with use of a robotic device. The robotic device can use information from an electronic image for preparing the recipient site.

[0308] Identification and preparation of the implant site and insertion of the implant can be supported by asurgical navigation system. In such a system, the position or orientation of a surgical instrument with respect to the patient's anatomy can be tracked in real-time in one or more 2D or 3D images. These 2D or 3D images can be calculated from images that were acquired preoperatively, such as MR or CT images. Non-image based surgical navigation systems that find axes or anatomical structures, for example with use of joint motion, can also be used. The position and orientation of the surgical instrument as well as the mold including alignment guides, surgical instrument guides, reaming guides, drill guides, saw guides, etc. can be determined from markers attached to these devices. These markers can be located by a detector using, for example, optical, acoustical or electromagnetic signals.

[0309] Identification and preparation of the implant site and insertion of the implant can also be supported with use of a C-arm system. The C-arm system can afford imaging of the joint in one or, preferably, multiple planes. The multiplanar imaging capability can aid in defining the shape of an articular surface. This information can be used to select an implant with a good fit to the articular surface. Currently available C-arm systems also afford cross-sectional imaging capability, for example for identification and preparation of the implant site and insertion of the implant. C-arm imaging can be combined with administration of radiographic contrast.

[0310] In still other embodiments, the surgical devices described herein can include one or more materials that harden to form a mold of the articular surface.

A wide-variety of materials that harden *in situ* have been described above including polymers that can be triggered to undergo a phase change, for example polymers that are liquid or semi-liquid and harden to solids or gels upon exposure to air, application of ultraviolet light, visible light, exposure to blood, water or other ionic changes. (See, also, U.S. Patent No. 6,443,988 to Felt et al. issued September 3, 2002 and documents cited therein). Non-limiting examples of suitable curable and hardening materials include polyurethane materials (e.g., U.S. Patent Nos. 6,443,988 to Felt et al., 5,288,797 to Khalil issued February 22, 1994, 4,098,626 to Graham et al. issued July 4, 1978 and 4,594,380 to Chapin et al. issued June 10, 1986; and Lu et al. (2000) *BioMaterials* 21(15):1595-1605 describing porous poly(L-lactide acid foams); hydrophilic polymers as disclosed, for example, in U.S. Patent 5,162,430; hydrogel materials such as those described in Wake et al. (1995) *Cell Transplantation* 4(3):275-279, Wiese et al. (2001) *J. Biomedical Materials Research* 54(2):179-188 and Marler et al. (2000) *Plastic Reconstruct. Surgery* 105(6):2049-2058; hyaluronic acid materials (e.g., Duranti et al. (1998) *Dermatologic Surgery* 24(12):1317-1325); expanding beads such as chitin beads (e.g., Yusof et al. (2001) *J. Biomedical Materials Research* 54(1):59-68); crystal free metals such as Liquidmetals®, and/or materials used in dental applications (See, e.g., Brauer and Antonucci, "Dental Applications" pp. 257-258 in "Concise Encyclopedia of Polymer Science and Engineering" and U.S. Patent No. 4,368,040 to Weissman issued January 11, 1983). Any biocompatible material that is sufficiently flowable to permit it to be delivered to the joint and there undergo complete cure *in situ* under physiologically acceptable conditions can be used. The material can also be biodegradable.

25 **[0311]** The curable materials can be used in conjunction with a surgical tool as described herein. For example, the surgical tool can include one or more apertures therein adapted to receive injections and the curable materials can be injected through the apertures. Prior to solidifying *in situ* the materials will conform to the articular surface facing the surgical tool and, accordingly, will form

a mirror image impression of the surface upon hardening, thereby recreating a normal or near normal articular surface. In addition, curable materials or surgical tools can also be used in conjunction with any of the imaging tests and analysis described herein, for example by molding these materials or surgical tools based
5 on an image of a joint.

[0312] FIG. 23 is a flow chart illustrating the steps involved in designing a mold for use in preparing a joint surface. Typically, the first step is to measure the size of the area of the diseased cartilage or cartilage loss **2100**. Once the size of the cartilage loss has been measured, the user can measure the thickness of the
10 adjacent cartilage **2120**, prior to measuring the curvature of the articular surface and/or the subchondral bone **2130**. Alternatively, the user can skip the step of measuring the thickness of the adjacent cartilage **2102**. Once an understanding and determination of the nature of the cartilage defect is determined, either a mold can be selected from a library of molds **3132** or a patient specific mold can be
15 generated **2134**. In either event, the implantation site is then prepared **2140** and implantation is performed **2142**. Any of these steps can be repeated by the optional repeat steps **2101, 2121, 2131, 2133, 2135, 2141**.

[0313] A variety of techniques can be used to derive the shape of the mold. For example, a few selected CT slices through the hip joint, along with a full spiral
20 CT through the knee joint and a few selected slices through the ankle joint can be used to help define the axes if surgery is contemplated of the knee joint. Once the axes are defined, the shape of the subchondral bone can be derived, followed by applying standardized cartilage loss. Other more sophisticated scanning
25 procedures can be used to derive this information without departing from the scope of the invention.

[0314] Turning now to tools for specific joint applications which are intended to teach the concept of the design as it would then apply to other joints in the body:

[0315] i. Knee Joint

[0316] When a total knee arthroplasty is contemplated, the patient can undergo an imaging test, as discussed in more detail above, that will demonstrate the articular anatomy of a knee joint, *e.g.* width of the femoral condyles, the tibial plateau etc. Additionally, other joints can be included in the imaging test thereby yielding information on femoral and tibial axes, deformities such as varus and valgus and other articular alignment. The imaging test can be an x-ray image, preferably in standing, load-bearing position, a CT scan or an MRI scan or combinations thereof. The articular surface and shape as well as alignment information generated with the imaging test can be used to shape the surgical assistance device, to select the surgical assistance device from a library of different devices with pre-made shapes and sizes, or can be entered into the surgical assistance device and can be used to define the preferred location and orientation of saw guides or drill holes or guides for reaming devices or other surgical instruments. Intraoperatively, the surgical assistance device is applied to the tibial plateau and subsequently the femoral condyle(s) by matching its surface with the articular surface or by attaching it to anatomic reference points on the bone or cartilage. The surgeon can then introduce a reamer or saw through the guides and prepare the joint for the implantation. By cutting the cartilage and bone along anatomically defined planes, a more reproducible placement of the implant can be achieved. This can ultimately result in improved postoperative results by optimizing biomechanical stresses applied to the implant and surrounding bone for the patient's anatomy and by minimizing axis malalignment of the implant. In addition, the surgical assistance device can greatly reduce the number of surgical instruments needed for total or unicompartamental knee arthroplasty. Thus, the use of one or more surgical assistance devices can help make joint arthroplasty more accurate, improve postoperative results, improve long-term implant survival, reduce cost by reducing the number of surgical instruments used. Moreover, the

use of one or more surgical assistance device can help lower the technical difficulty of the procedure and can help decrease operating room ("OR") times..

[0317] Thus, surgical tools described herein can also be designed and used to control drill alignment, depth and width, for example when preparing a site to receive an implant. For example, the tools described herein, which typically conform to the joint surface, can provide for improved drill alignment and more accurate placement of any implant. An anatomically correct tool can be constructed by a number of methods and can be made of any material, preferably a translucent material such as plastic, Lucite, silastic, SLA or the like, and typically is a block-like shape prior to molding.

[0318] FIG. 24A depicts, in cross-section, an example of a mold **600** for use on the tibial surface having an upper surface **620**. The mold **600** contains an aperture **625** through which a surgical drill or saw can fit. The aperture guides the drill or saw to make the proper hole or cut in the underlying bone **610** as illustrated in FIGS. 21B-D. Dotted lines **632** illustrate where the cut corresponding to the aperture will be made in bone.

[0319] FIG. 24B depicts, a mold **608** suitable for use on the femur. As can be appreciated from this perspective, additional apertures are provided to enable additional cuts to the bone surface. The apertures **605** enable cuts **606** to the surface of the femur. The resulting shape of the femur corresponds to the shape of the interior surface of the femoral implant, typically as shown in FIG. 21E. Additional shapes can be achieved, if desired, by changing the size, orientation and placement of the apertures. Such changes would be desired where, for example, the interior shape of the femoral component of the implant requires a different shape of the prepared femur surface.

[0320] Turning now to FIG. 25, a variety of illustrations are provided showing a tibial cutting block and mold system. FIG. 25A illustrates the tibial cutting block **2300** in conjunction with a tibia **2302** that has not been resected. In

this depiction, the cutting block **2300** consists of at least two pieces. The first piece is a patient specific interior piece **2310** or mold that is designed on its inferior surface **2312** to mate, or substantially mate, with the existing geography of the patient's tibia **2302**. The superior surface **2314** and side surfaces **2316** of the first piece **2310** are configured to mate within the interior of an exterior piece **2320**. The reusable exterior piece **2320** fits over the interior piece **2310**. The system can be configured to hold the mold onto the bone.

[0321] The reusable exterior piece has a superior surface **2322** and an inferior surface **2324** that mates with the first piece **2310**. The reusable exterior piece **2320** includes cutting guides **2328**, to assist the surgeon in performing the tibial surface cut described above. As shown herein a plurality of cutting guides can be provided to provide the surgeon a variety of locations to choose from in making the tibial cut. If necessary, additional spacers can be provided that fit between the first patient configured, or molded, piece **2310** and the second reusable exterior piece, or cutting block, **2320**.

[0322] The variable nature of the interior piece facilitates obtaining the most accurate cut despite the level of disease of the joint because it positions the exterior piece **2320** such that it can achieve a cut that is perpendicular to the mechanical axis. Either the interior piece **2310** or the exterior piece **2320** can be formed out of any of the materials discussed above in Section II, or any other suitable material. Additionally, a person of skill in the art will appreciate that the invention is not limited to the two piece configuration described herein. The reusable exterior piece **2320** and the patient specific interior piece **2310** can be a single piece that is either patient specific (where manufacturing costs of materials support such a product) or is reusable based on a library of substantially defect conforming shapes developed in response to known or common tibial surface sizes and defects.

[0323] The interior piece **2310** is typically molded to the tibia including the subchondral bone and/or the cartilage. The surgeon will typically remove any

residual meniscal tissue prior to applying the mold. Optionally, the interior surface **2312** of the mold can include shape information of portions or all of the menisci.

[0324] Turning now to **FIG. 25B-D**, a variety of views of the removable exterior piece **2320**. The top surface **2322** of the exterior piece can be relatively flat. The lower surface **2324** which abuts the interior piece conforms to the shape of the upper surface of the interior piece. In this illustration the upper surface of the interior piece is flat, therefore the lower surface **2324** of the reusable exterior surface is also flat to provide an optimal mating surface.

[0325] A guide plate **2326** is provided that extends along the side of at least a portion of the exterior piece **2320**. The guide plate **2326** provides one or more slots or guides **2328** through which a saw blade can be inserted to achieve the cut desired of the tibial surface. Additionally, the slot, or guide, can be configured so that the saw blade cuts at a line perpendicular to the mechanical axis, or so that it cuts at a line that is perpendicular to the mechanical axis, but has a 4-7° slope in the sagittal plane to match the normal slope of the tibia.

[0326] Optionally, a central bore **2330** can be provided that, for example, enables a drill to ream a hole into the bone for the stem of the tibial component of the knee implant.

[0327] **FIGS. 25E-H** illustrate the interior, patient specific, piece **2310** from a variety of perspectives. **FIG. 25E** shows a side view of the piece showing the uniform superior surface **2314** and the uniform side surfaces **2316** along with the irregular inferior surface **2316**. The inferior surface mates with the irregular surface of the tibia **2302**. **FIG. 25F** illustrates a superior view of the interior, patient, specific piece of the mold **2310**. Optionally having an aperture **2330**. **FIG. 25G** illustrates an inferior view of the interior patient specific mold piece **2310** further illustrating the irregular surface which includes convex and concave portions to the surface, as necessary to achieve optimal mating with the surface of the tibia. **FIG. 25H** illustrates cross-sectional views of the interior patient specific mold

piece **2310**. As can be seen in the cross-sections, the surface of the interior surface changes along its length.

[0328] As is evident from the views shown in **FIG. 25B** and **D**, the length of the guide plate **2326** can be such that it extends along all or part of the tibial plateau, e.g. where the guide plate **2326** is asymmetrically positioned as shown in **FIG. 25B** or symmetrical as in **FIG. 23D**. If total knee arthroplasty is contemplated, the length of the guide plate **2326** typically extends along all of the tibial plateau. If unicompartamental arthroplasty is contemplated, the length of the guide plate typically extends along the length of the compartment that the surgeon will operate on. Similarly, if total knee arthroplasty is contemplated, the length of the molded, interior piece **2310** typically extends along all of the tibial plateau; it can include one or both tibial spines. If unicompartamental arthroplasty is contemplated, the length of the molded interior piece typically extends along the length of the compartment that the surgeon will operate on; it can optionally include a tibial spine.

[0329] Turning now to **FIG. 25I**, an alternative embodiment is depicted of the aperture **2330**. In this embodiment, the aperture features lateral protrusions to accommodate using a reamer or punch to create an opening in the bone that accepts a stem having flanges.

[0330] **FIGS. 25J** and **M** depict alternative embodiments of the invention designed to control the movement and rotation of the cutting block **2320** relative to the mold **2310**. As shown in **FIG. 25J** a series of protrusions, illustrated as pegs **2340**, are provided that extend from the superior surface of the mold. As will be appreciated by those of skill in the art, one or more pegs or protrusions can be used without departing from the scope of the invention. For purposes of illustration, two pegs have been shown in **FIG. 25J**. Depending on the control desired, the pegs **2340** are configured to fit within, for example, a curved slot **2342** that enables rotational adjustment as illustrated in **FIG. 23K** or within a recess **2344** that conforms in shape to the peg **2340** as shown in **FIG. 25L**. As will be

appreciated by those of skill in the art, the recess **2344** can be sized to snugly encompass the peg or can be sized larger than the peg to allow limited lateral and rotational movement.

5 **[0331]** As illustrated in **FIG. 25M** the surface of the mold **2310** can be configured such that the upper surface forms a convex dome **2350** that fits within a concave well **2352** provided on the interior surface of the cutting block **2320**. This configuration enables greater rotational movement about the mechanical axis while limiting lateral movement or translation.

10 **[0332]** Other embodiments and configurations could be used to achieve these results without departing from the scope of the invention.

15 **[0333]** As will be appreciated by those of skill in the art, more than two pieces can be used, where appropriate, to comprise the system. For example, the patient specific interior piece **2310** can be two pieces that are configured to form a single piece when placed on the tibia. Additionally, the exterior piece **2320** can be two components. The first component can have, for example, the cutting guide apertures **2328**. After the resection using the cutting guide aperture **2328** is made, the exterior piece **2320** can be removed and a secondary exterior piece **2320'** can be used which does not have the guide plate **2326** with the cutting guide apertures **2328**, but has the aperture **2330** which facilitates boring into the tibial surface an aperture to receive a stem of the tibial component of the knee implant. 20 Any of these designs could also feature the surface configurations shown in **FIGS. 25J-M**, if desired.

25 **[0334]** **FIG. 25N** illustrates an alternative design of the cutting block **2320** that provides additional structures **2360** to protect, for example, the cruciate ligaments, from being cut during the preparation of the tibial plateau. These additional structures can be in the form of indented guides **2360**, as shown in **FIG. 25N** or other suitable structures.

[0335] FIG. 25o illustrates a cross-section of a system having anchoring pegs 2362 on the surface of the interior piece 2310 that anchor the interior piece 2310 into the cartilage or meniscal area.

5 [0336] FIGS. 25P AND Q illustrate a device 2300 configured to cover half of a tibial plateau such that it is unicompartmental.

[0337] Turning now to FIG. 26, a femoral mold system is depicted that facilitates preparing the surface of the femur such that the finally implanted femoral implant will achieve optimal mechanical and anatomical axis alignment.

10 [0338] FIG. 26A illustrates the femur 2400 with a first portion 2410 of the mold placed thereon. In this depiction, the top surface of the mold 2412 is provided with a plurality of apertures. In this instance the apertures consist of a pair of rectangular apertures 2414, a pair of square apertures 2416, a central bore aperture 2418 and a long rectangular aperture 2420. The side surface 2422 of the first portion 2410 also has a rectangular aperture 2424. Each of the apertures is
15 larger than the eventual cuts to be made on the femur so that, in the event the material the first portion of the mold is manufactured from a soft material, such as plastic, it will not be inadvertently cut during the joint surface preparation process. Additionally, the shapes can be adjusted, e.g., rectangular shapes made trapezoidal, to give a greater flexibility to the cut length along one area, without
20 increasing flexibility in another area. As will be appreciated by those of skill in the art, other shapes for the apertures, or orifices, can be changed without departing from the scope of the invention.

25 [0339] FIG. 26B illustrates a side view of the first portion 2410 from the perspective of the side surface 2422 illustrating the aperture 2424. As illustrated, the exterior surface 2411 has a uniform surface which is flat, or relatively flat configuration while the interior surface 2413 has an irregular surface that conforms, or substantially conforms, with the surface of the femur.

[0340] FIG 26c illustrates another side view of the first, patient specific molded, portion **2410**, more particularly illustrating the irregular surface **2413** of the interior. FIG. 26D illustrates the first portion **2410** from a top view. The center bore aperture **2418** is optionally provided to facilitate positioning the first piece and to prevent central rotation.

[0341] FIG. 26D illustrates a top view of the first portion **2410**. The bottom of the illustration corresponds to an anterior location relative to the knee joint. From the top view, each of the apertures is illustrated as described above. As will be appreciated by those of skill in the art, the apertures can be shaped differently without departing from the scope of the invention.

[0342] Turning now to FIG. 26E, the femur **2400** with a first portion **2410** of the cutting block placed on the femur and a second, exterior, portion **2440** placed over the first portion **2410** is illustrated. The second, exterior, portion **2440** features a series of rectangular grooves (**2442-2450**) that facilitate inserting a saw blade therethrough to make the cuts necessary to achieve the femur shape illustrated in FIG. 21E. These grooves can enable the blade to access at a 90° angle to the surface of the exterior portion, or, for example, at a 45° angle. Other angles are also possible without departing from the scope of the invention.

[0343] As shown by the dashed lines, the grooves (**2442-2450**) of the second portion **2440**, overlay the apertures of the first layer.

[0344] FIG. 26F illustrates a side view of the second, exterior, cutting block portion **2440**. From the side view a single aperture **2450** is provided to access the femur cut. FIG. 26G is another side view of the second, exterior, portion **2440** showing the location and relative angles of the rectangular grooves. As evidenced from this view, the orientation of the grooves **2442**, **2448** and **2450** is perpendicular to at least one surface of the second, exterior, portion **2440**. The orientation of the grooves **2444**, **2446** is at an angle that is not perpendicular to at least one surface of the second, exterior portion **2440**. These grooves (**2444**,

2446) facilitate making the angled chamfer cuts to the femur. **FIG. 26H** is a top view of the second, exterior portion **2440**. As will be appreciated by those of skill in the art, the location and orientation of the grooves will change depending upon the design of the femoral implant and the shape required of the femur to communicate with the implant.

[0345] **FIG. 26I** illustrates a spacer **2401** for use between the first portion **2410** and the second portion **2440**. The spacer **2401** raises the second portion relative to the first portion, thus raising the area at which the cut through groove **2424** is made relative to the surface of the femur. As will be appreciated by those of skill in the art, more than one spacer can be employed without departing from the scope of the invention. Spacers can also be used for making the tibial cuts. Optional grooves or channels **2403** can be provided to accommodate, for example, pins **2460** shown in **FIG. 26J**.

[0346] Similar to the designs discussed above with respect to **FIG. 25**, alternative designs can be used to control the movement and rotation of the cutting block **2440** relative to the mold **2410**. As shown in **FIG. 26J** a series of protrusions, illustrated as pegs **2460**, are provided that extend from the superior surface of the mold. These pegs or protrusions can be telescoping to facilitate the use of molds if necessary. As will be appreciated by those of skill in the art, one or more pegs or protrusions can be used without departing from the scope of the invention. For purposes of illustration, two pegs have been shown in **FIG. 26J**. Depending on the control desired, the pegs **2460** are configured to fit within, for example, a curved slot that enables rotational adjustment similar to the slots illustrated in **FIG. 25K** or within a recess that conforms in shape to the peg, similar to that shown in **FIG. 25L** and described with respect to the tibial cutting system. As will be appreciated by those of skill in the art, the recess **2462** can be sized to snugly encompass the peg or can be sized larger than the peg to allow limited lateral and rotational movement.

[0347] As illustrated in **FIG. 26K** the surface of the mold **2410** can be configured such that the upper surface forms a convex dome **2464** that fits within a concave well **2466** provided on the interior surface of the cutting block **2440**. This configuration enables greater rotational movement about the mechanical axis
5 while limiting lateral movement or translation.

[0348] In installing an implant, first the tibial surface is cut using a tibial block, such as those shown in **FIG. 26**. The patient specific mold is placed on the femur. The knee is then placed in extension and spacers **2470**, such as those shown in **FIG. 26I**, or shims are used, if required, until the joint optimal function is
10 achieved in both extension and flexion. The spacers, or shims, are typically of an incremental size, *e.g.*, 5 mm thick to provide increasing distance as the leg is placed in extension and flexion. A tensiometer can be used to assist in this determination or can be incorporated into the mold or spacers in order to provide optimal results. The design of tensiometers are known in the art and are not
15 included herein to avoid obscuring the invention. Suitable designs include, for example, those described in U.S. Patent 5,630,820 to Todd issued May 20, 1997.

[0349] As illustrated in **FIGS. 26N** (sagittal view) and **26M** (coronal view), the interior surface **2413** of the mold **2410** can include small teeth **2465** or extensions that can help stabilize the mold against the cartilage **2466** or subchondral bone
20 **2467**.

[0350] Turning now to **FIG. 27**, a variety of illustrations are provided showing a patellar cutting block and mold system. **FIGS. 27A-c** illustrates the patellar cutting block **2700** in conjunction with a patella **2702** that has not been resected. In this depiction, the cutting block **2700** can consist of only one piece or
25 a plurality of pieces, if desired. The inner surface **2703** is patient specific and designed to mate, or substantially mate, with the existing geography of the patient's patella **2702**. Small openings are present **2707** to accept the saw. The mold or block can have only one or multiple openings. The openings can be larger than the saw in order to allow for some rotation or other fine adjustments. **FIG. 27A**

is a view in the sagittal plane **S**. The quadriceps tendon **2704** and patellar tendon **2705** are shown.

[0351] FIG. **27B** is a view in the axial plane **A**. The cartilage **2706** is shown. The mold can be molded to the cartilage or the subchondral bone or combinations thereof. FIG. **27C** is a frontal view **F** of the mold demonstrating the opening for the saw **2707**. The dashed line indicates the relative position of the patella **2702**.

[0352] FIGS. **27D** (sagittal view) and **E** (axial view) illustrate a patellar cutting block **2708** in conjunction with a patella **2702** that has not been resected. In this depiction, the cutting block **2708** consists of at least two pieces. The first piece is a patient specific interior piece **2710** or mold that is designed on its inferior surface **2712** to mate, or substantially mate, with the existing geography of the patient's patella **2702**. The posterior surface **2714** and side surfaces **2716** of the first piece **2710** are configured to mate within the interior of an exterior piece **2720**. The reusable exterior piece **2720** fits over the interior piece **2710** and holds it onto the patella. The reusable exterior piece has an interior surface **2724** that mates with the first piece **2710**. The reusable exterior piece **2720** includes cutting guides **2707**, to assist the surgeon in performing the patellar surface cut. A plurality of cutting guides can be provided to provide the surgeon a variety of locations to choose from in making the patellar cut. If necessary, additional spacers can be provided that fit between the first patient configured, or molded, piece **2710** and the second reusable exterior piece, or cutting block, **2720**.

[0353] The second reusable exterior piece, or cutting block, **2720**, can have grooves **2722** and extensions **2725** designed to mate with surgical instruments such as a patellar clamp **2726**. The patellar clamp **2726** can have ring shaped graspers **2728** and locking mechanisms, for example ratchet-like **2730**. The opening **2732** in the grasper fits onto the extension **2725** of the second reusable exterior piece **2720**. Portions of a first portion of the handle of the grasper can be at an oblique angle **2734** relative to the second portion of the handle, or curved (not shown), in order to facilitate insertion. Typically the portion of the grasper that

will be facing towards the intra-articular side will have an oblique or curved shaped thereby allowing a slightly smaller incision.

[0354] The variable nature of the interior piece facilitates obtaining the most accurate cut despite the level of disease of the joint because it positions the exterior piece **2720** in the desired plane. Either the interior piece **2710** or the exterior piece **2720** can be formed out of any of the materials discussed above in Section II, or any other suitable material. Additionally, a person of skill in the art will appreciate that the invention is not limited to the two piece configuration described herein. The reusable exterior piece **2720** and the patient specific interior piece **2710** can be a single piece that is either patient specific (where manufacturing costs of materials support such a product) or is reusable based on a library of substantially defect conforming shapes developed in response to known or common tibial surface sizes and defects.

[0355] The interior piece **2710** is typically molded to the patella including the subchondral bone and/or the cartilage.

[0356] From this determination, an understanding of the amount of space needed to balance the knee is determined and an appropriate number of spacers is then used in conjunction with the cutting block and mold to achieve the cutting surfaces and to prevent removal of too much bone. Where the cutting block has a thickness of, for example, 10 mm, and each spacer has a thickness of 5 mm, in preparing the knee for cuts, two of the spacers would be removed when applying the cutting block to achieve the cutting planes identified as optimal during flexion and extension. Similar results can be achieved with ratchet or jack like designs interposed between the mold and the cut guide.

[0357] **ii. Hip Joint**

[0358] Turning now to **FIG. 28**, a variety of views showing sample mold and cutting block systems for use in the hip joint are shown. **FIG. 28A** illustrates femur **2510** with a mold and cutting block system **2520** placed to provide a cutting plane

2530 across the femoral neck **2512** to facilitate removal of the head **2514** of the femur and creation of a surface **2516** for the hip ball prosthesis.

[0359] FIG. **28B** illustrates a top view of the cutting block system **2520**. The cutting block system **2520** includes an interior, patient specific, molded section **2524** and an exterior cutting block surface **2522**. The interior, patient specific, molded section **2524** can include a canal **2526** to facilitate placing the interior section **2524** over the neck of the femur. As will be appreciated by those of skill in the art, the width of the canal will vary depending upon the rigidity of the material used to make the interior molded section. The exterior cutting block surface **2522** is configured to fit snugly around the interior section. Additional structures can be provided, similar to those described above with respect to the knee cutting block system, that control movement of the exterior cutting block **2524** relative to interior mold section **2522**, as will be appreciated by those of skill in the art. Where the interior section **2524** encompasses all or part of the femoral neck, the cutting block system can be configured such that it aids in removal of the femoral head once the cut has been made by, for example, providing a handle **2501**.

[0360] FIG. **28c** illustrates a second cutting block system **2550** that can be placed over the cut femur to provide a guide for reaming after the femoral head has been removed using the cutting block shown in FIG. **28A**. FIG. **28D** is a top view of the cutting block shown in FIG. **28c**. As will be appreciated by those of skill in the art, the cutting block shown in FIG. **28c-d**, can be one or more pieces. As shown in FIG. **28E**, the aperture **2552** can be configured such that it enables the reaming for the post of the implant to be at a 90° angle relative to the surface of femur. Alternatively, as shown in FIG. **28F**, the aperture **2552** can be configured to provide an angle other than 90° for reaming, if desired.

[0361] FIGS. **29A** (sagittal view) and **29B** (frontal view, down onto mold) illustrates a mold system **2955** for the acetabulum **2957**. The mold can have grooves **2959** that stabilize it against the acetabular rim **2960**. Surgical

instruments, e.g. reamers, can be passed through an opening in the mold **2956**. The side wall of the opening **2962** can guide the direction of the reamer or other surgical instruments. Metal sleeves **2964** can be inserted into the side wall **2962** thereby protecting the side wall of the mold from damage. The metal sleeves **2964** can have lips **2966** or overhanging edges that secure the sleeve against the mold and help avoid movement of the sleeve against the articular surface.

[0362] FIG. **29c** is a frontal view of the same mold system shown in Figs. **29A** and **29B**. A groove **2970** has been added at the 6 and 12 o'clock positions. The groove can be used for accurate positioning or placement of surgical instruments. Moreover, the groove can be useful for accurate placement of the acetabular component without rotational error. Someone skilled in the art will recognize that more than one groove or internal guide can be used in order to not only reduce rotational error but also error related to tilting of the implant. As seen FIG **29D**, the implant **2975** can have little extensions **2977** matching the grooves thereby guiding the implant placement. The extensions **2977** can be a permanent part of the implant design or they can be detachable. Note metal rim **2979** and inner polyethylene cup **2980** of the acetabular component.

[0363] FIG. **29D** illustrates a cross-section of a system where the interior surface **2960** of the molded section **2924** has teeth **2962** or grooves to facilitate grasping the neck of the femur.

[0364] B. SMALL, FOCAL CARTILAGE DEFECT

[0365] After identification of the cartilage defect and marking of the skin surface using the proprietary U-shaped cartilage defect locator device as described herein, a 3 cm incision is placed and the tissue retractors are inserted. The cartilage defect is visualized.

[0366] A first Lucite block matching the 3D surface of the femoral condyle is placed over the cartilage defect. The central portion of the Lucite block contains a drill hole with an inner diameter of, for example, 1.5 cm, corresponding to the

diameter of the base plate of the implant. A standard surgical drill with a drill guide for depth control is inserted through the Lucite block, and the recipient site is prepared for the base component of the implant. The drill and the Lucite block are then removed.

5 **[0367]** A second Lucite block of identical outer dimensions is then placed over the implant recipient site. The second Lucite block has a rounded, cylindrical extension matching the size of the first drill hole (and matching the shape of the base component of the implant), with a diameter 0.1 mm smaller than the first drill hole and 0.2 mm smaller than that of the base of the implant. The cylindrical
10 extension is placed inside the first drill hole.

[0368] The second Lucite block contains a drill hole extending from the external surface of the block to the cylindrical extension. The inner diameter of the second drill hole matches the diameter of the distal portion of the fin-shaped stabilizer strut of the implant, *e.g.* 3 mm. A drill, *e.g.* with 3 mm diameter, with a
15 drill guide for depth control is inserted into the second hole and the recipient site is prepared for the stabilizer strut with a four fin and step design. The drill and the Lucite block are then removed.

[0369] A plastic model/trial implant matching the 3-D shape of the final implant with a diameter of the base component of 0.2 mm less than that of the
20 final implant and a cylindrical rather than tapered strut stabilizer with a diameter of 0.1 mm less than the distal portion of the final implant is then placed inside the cartilage defect. The plastic model/trial implant is used to confirm alignment of the implant surface with the surrounding cartilage. The surgeon then performs final adjustments.

25 **[0370]** The implant is subsequently placed inside the recipient site. The anterior fin of the implant is marked with red color and labeled "A." The posterior fin is marked green with a label "P" and the medial fin is color coded yellow with a label "M." The Lucite block is then placed over the implant. A plastic hammer is

utilized to advance the implant slowly into the recipient site. A press fit is achieved with help of the tapered and four fin design of the strut, as well as the slightly greater diameter (0.1 mm) of the base component relative to the drill hole. The Lucite block is removed. The tissue retractors are then removed. Standard surgical technique is used to close the 3 cm incision. The same procedure described above for the medial femoral condyle can also be applied to the lateral femoral condyle, the medial tibial plateau, the lateral tibial plateau and the patella. Immediate stabilization of the device can be achieved by combining it with bone cement if desired.

10 **[0371] IV. KITS**

[0372] Also described herein are kits comprising one or more of the methods, systems and/or compositions described herein. In particular, a kit can include one or more of the following: instructions (methods) of obtaining electronic images; systems or instructions for evaluating electronic images; one or more computer means capable of analyzing or processing the electronic images; and/or one or more surgical tools for implanting an articular repair system. The kits can include other materials, for example, instructions, reagents, containers and/or imaging aids (*e.g.*, films, holders, digitizers, etc.).

[0373]T The following examples are included to more fully illustrate the present invention. Additionally, these examples provide preferred embodiments of the invention and are not meant to limit the scope thereof.

[0374] Example 1: Design and construction of a three-dimensional articular repair system

25 **[0375]** Areas of cartilage are imaged as described herein to detect areas of cartilage loss and/or diseased cartilage. The margins and shape of the cartilage and subchondral bone adjacent to the diseased areas are determined. The thickness of the cartilage is determined. The size of the articular repair system is determined based on the above measurements. (Figs. 12-14). In particular, the

repair system is either selected (based on best fit) from a catalogue of existing, pre-made implants with a range of different sizes and curvatures or custom-designed using CAD/CAM technology. The library of existing shapes is typically on the order of about 30 sizes.

5 **[0376]** The implant is a chromium cobalt implant (see also Figures 12-14 and 17-19). The articular surface is polished and the external dimensions slightly greater than the area of diseased cartilage. The shape is adapted to achieve perfect or near perfect joint congruity utilizing shape information of surrounding cartilage and underlying subchondral bone. Other design features of the implant
10 can include: a slanted (60- to 70-degree angle) interface to adjacent cartilage; a broad-based base component for depth control; a press fit design of base component; a porous coating of base component for ingrowth of bone and rigid stabilization; a dual peg design for large defects implant stabilization, also porous coated (**FIG. 12A**); a single stabilizer strut with tapered, four fin and step design for
15 small, focal defects, also porous coated (**FIG. 12B**); and a design applicable to femoral resurfacing (convex external surface) and tibial resurfacing (concave external surface).

[0377] Example 2: Minimally Invasive, Arthroscopically Assisted Surgical Technique

20 **[0378]** The articular repair systems are inserted using arthroscopic assistance. The device does not require the 15 to 30 cm incision utilized in unicompartmental and total knee arthroplasties. The procedure is performed under regional anesthesia, typically epidural anesthesia. The surgeon can apply a tourniquet on the upper thigh of the patient to restrict the blood flow to the knee
25 during the procedure. The leg is prepped and draped in sterile technique. A stylette is used to create two small 2 mm ports at the anteromedial and the anterolateral aspect of the joint using classical arthroscopic technique. The arthroscope is inserted via the lateral port. The arthroscopic instruments are inserted via the medial port. The cartilage defect is visualized using the

arthroscope. A cartilage defect locator device is placed inside the diseased cartilage. The probe has a U-shape, with the first arm touching the center of the area of diseased cartilage inside the joint and the second arm of the U remaining outside the joint. The second arm of the U indicates the position of the cartilage relative to the skin. The surgeon marks the position of the cartilage defect on the skin. A 3 cm incision is created over the defect. Tissue retractors are inserted and the defect is visualized.

[0379] A translucent Lucite block matching the 3D shape of the adjacent cartilage and the cartilage defect is placed over the cartilage defect (Fig. 13). For larger defects, the Lucite block includes a lateral slot for insertion of a saw. The saw is inserted and a straight cut is made across the articular surface, removing an area slightly larger than the diseased cartilage. The center of the Lucite block contains two drill holes with a 7.2 mm diameter. A 7.1 mm drill with drill guide controlling the depth of tissue penetration is inserted via the drill hole. Holes for the cylindrical pegs of the implant are created. The drill and the Lucite block are subsequently removed.

[0380] A plastic model/trial implant of the mini-repair system matching the outer dimensions of the implant is then inserted. The trial implant is utilized to confirm anatomic placement of the actual implant. If indicated, the surgeon can make smaller adjustments at this point to improve the match, e.g. slight expansion of the drill holes or adjustment of the cut plane.

[0381] The implant is then inserted with the pegs pointing into the drill holes. Anterior and posterior positions of the implant are color-coded; specifically the anterior peg is marked with a red color and a small letter "A", while the posterior peg has a green color and a small letter "P". Similarly, the medial aspect of the implant is color-coded yellow and marked with a small letter "M" and the lateral aspect of the implant is marked with a small letter "L". The Lucite block is then placed on the external surface of the implant and a plastic hammer is used to

gently advance the pegs into the drill holes. The pegs are designed to achieve a press fit.

[0382] The same technique can be applied in the tibia. The implant has a concave articular surface matching the 3D shape of the tibial plateau. Immediate stabilization of the device can be achieved by combining it with bone cement if desired.

[0383] The foregoing description of embodiments of the present invention has been provided for the purposes of illustration and description. It is not intended to be exhaustive or to limit the invention to the precise forms disclosed. Many modifications and variations will be apparent to the practitioner skilled in the art. The embodiments were chosen and described in order to best explain the principles of the invention and its practical application, thereby enabling others skilled in the art to understand the invention and the various embodiments and with various modifications that are suited to the particular use contemplated. It is intended that the scope of the invention be defined by the following claims and equivalents thereof.

WHAT IS CLAIMED:

1. A method of designing an articular implant comprising the steps of
obtaining an image of a joint, wherein the image includes at least one of
normal cartilage and diseased cartilage;
5 reconstructing dimensions of the diseased cartilage surface to correspond
to normal cartilage; and
designing the articular implant to match the dimensions of the
reconstructed diseased cartilage surface or an area greater than the diseased
cartilage surface.

10

2. The method of claim 1, wherein the image is selected from the group
consisting of MRI, CT, ultrasound, digital tomosynthesis, optical coherence
tomography and combinations thereof.

15

3. The method of claim 1, wherein the reconstruction comprises obtaining
a parametric surface that follows the contour of the normal cartilage, the
parametric surface comprising control points that extend the contour of the normal
cartilage to the diseased cartilage.

20

4. The method of claim 3, wherein the parametric surface comprises a B-
spline surface.

25

5. The method of claim 1, wherein the reconstruction comprises
obtaining a binary image of cartilage by extracting cartilage from the image,
wherein diseased cartilage appears as indentations in the binary image; and
performing a morphological closing operation to determine the shape of an
implant to fill the areas of diseased cartilage.

6. The method of claim 5, wherein the morphological closing operation is performed in two or three-dimensions using a structuring element.

5 7. The method of claim 5, wherein the morphological closing operation comprises a dilation followed by an erosion.

8. A system for evaluating the fit of an articular repair system into a joint, the system comprising,

10 one or more computing means capable of superimposing a three-dimensional or a two-dimensional cross-sectional image of a joint and an image of an articular repair system to determine the fit of the articular repair system.

15 9. The system of claim 8, wherein the computing means is capable of merging the images of the joint and the articular repair system into common coordinate system.

10. The system of claim 8, wherein the computing means is capable of rotating or moving the images with respect to each other.

20 11. The system of claim 8, wherein the images are three-dimensional.

25 12. The system of claim 11, wherein the images comprise three-dimensional representations of at least one articular structure and of the articular repair system.

13. The system of claim 11, wherein the three-dimensional representations are generated using a parametric surface representation.

14. The system of claim 8, wherein the images comprise one or more cross-sectional 2-D images.

5 15. The system of claim 14, wherein the 2-D cross-sectional images are reconstructed in multiple planes.

16. The system of claim 8, wherein the computing means is capable of selecting an articular repair system having the best fit.

10 17. The system of claim 8, wherein the computing means is capable highlighting areas of poor alignment between the articular repair system and the surrounding articular surfaces.

15 18. A surgical tool for preparing a joint to receive an implant, the tool comprising one or more surfaces or members that conform to the shape of the articular surfaces of the joint.

19. The surgical tool of claim 18, wherein the joint is a knee and the articular surface comprises a femoral condyle or a tibial plateau.

20 20. The surgical tool of claim 18, wherein the tool comprises Lucite or silastic.

21. The surgical tool of claim 18, wherein the tool is re-useable.

25 22. The surgical tool of claim 21, wherein the tool comprises an array of adjustable, closely spaced pins.

23. The surgical tool of claim 18, further comprising an aperture therein, wherein the dimensions of the aperture are smaller or equal to the dimensions of the implant.

5 24. The surgical tool of claim 18, further comprising one or more apertures adapted to receive one or more injectables.

25. The surgical tool of claim 24, further comprising one or more curable compositions.

10

26. The surgical tool of claim 25, wherein the curable compositions are injected through the apertures.

15

27. A method of evaluating the fit of an articular repair system into a joint, the method comprising

obtaining one or more three-dimensional or two-dimensional cross-sectional images of a joint, wherein the joint includes at least one defect or diseased area;

20

obtaining one or more representations or images of one or more articular repair systems designed to repair the defect or diseased area; and

evaluating the images to determine the articular repair system that best fits the defect.

25

28. The method of claim 27, wherein the evaluating comprises superimposing the images to determine the fit of the articular repair system into the joint.

29. The method of claim 27, wherein the images of the joint and the articular repair system are merged into common coordinate system.

30. The method of claim 27, wherein the images are three-dimensional.

5 31. The method of claim 30, wherein the images comprise three-dimensional representations of at least one articular structure and of the articular repair system.

10 32. The method of claim 31, wherein the three-dimensional representations are generated using a parametric surface representation.

33. The method of claim 27, wherein the images comprise one or more cross-sectional 2-D images.

15 34. The method of claim 33, wherein the 2-D cross-sectional images are reconstructed in multiple planes.

35. The method of claim 27, wherein the evaluation is performed by computer.

20 36. The method of claim 27, wherein the evaluation is performed by manual visual inspection.

25 37. The method of claim 27, wherein the image of the joint is obtained using a C-arm system.

38. The method of claim 37, wherein the image of the joint is obtained using radiographic contrast.

39. A method of placing an implant for treatment of an area of diseased cartilage or an area slightly greater than the diseased cartilage into an articular surface having a defect or diseased area, the method comprising the step of imaging the joint using a C-arm system during placement of the implant, identifying biomechanical or anatomical axes thereby accurately placing the implant into a defect or diseased area.

40. A customizable implant configured for placement between joint surfaces formed by inserting a hollow device having an aperture and a lumen into a target joint, and injecting material into the hollow device to form an implant..

41. A customizable implant configured for placement between joint surfaces formed by inserting a retaining device that engages at least a portion of one joint surface in a joint and injecting material into an aperture of the retaining device to form an implant.

42. The implant of claims 40 and 41 wherein the implant is removed from the joint after the material is injected.

43. The implant of claims 40 and 41 wherein the implant is processed after the material is injected.

44. The implant of claim 42 wherein the implant is installed between the joint surfaces.

45. The implants of claim 40 and 41 wherein the implant is formed outside the joint.

46. The implants of claims 40 and 41 wherein the implant is formed inside the joint.

47. The implants of claim 40 and 41 wherein the implant is fixed within the joint.

48. The implants of claim 40 and 41 wherein the fit of the implant is tested in situ.

49. The implant of claim 40 wherein a second hollow device having an aperture and a lumen is inserted into the first hollow device.

50. The implant of claim 40 wherein a second hollow device having an aperture and a lumen is inserted into the joint adjacent the first hollow device.

5 51. The implant of claims 49 and 50 wherein a third hollow device is inserted into the joint wherein the third hollow device communicates with at least one of the first hollow device and second hollow device.

52. The implant of claim 40 wherein the hollow device has a lumen of variable thickness.

10 53. The implant of claim 40 wherein the hollow device has a lumen of variable stiffness.

54. The implant of claims 40 and 41 wherein the device conforms to at least one joint surface.

15 55. The implant of claims 40 and 41 wherein the device abuts at least one joint surface.

56. The implant of claims 40 and 41 wherein the device surrounds a defect within a joint.

57. The implant of claims 40 and 41 wherein the device extends beyond at least one perimeter of the joint.

20 58. The implant of claim 41 wherein the retaining device has an aperture.

59. The implant of claim 41 wherein the retaining device engages a joint surface along its perimeter and forms a cavity thereunder.

25 60. The implant of claim 41 wherein the joint surface is at least one of meniscal surface and subchondral bone.

61. The implant of claim 41 wherein the joint surface is prepared prior to injection by at least one of meniscal removal, aperture creation, and abrasion.

62. The implant of claims 40 and 41 wherein the injection material is selected from the group consisting of: polymer, metal, gases, and crystal free metals.

63. The implant of claims 40 and 41 wherein the joint surface is prepared to provide a cylindrical opening.

64. The implant of claims 63 wherein the injecting material is located within the cylindrical opening on the joint surface and forms an anchoring device.

65. A tool comprising:

a mold having a surface for engaging a joint surface;

a block that communicates with the mold; and

at least one guide aperture in the block.

66. The tool of claim 65 wherein the mold and the block are integrally formed.

67. The tool of claim 65 wherein the mold is formed to conform to the joint surface on at least one surface.

68. The tool of claim 65 wherein the mold has at least one aperture positioned below the at least one guide aperture in the block.

69. The tool of claim 65 wherein the mold and the block have a plurality of apertures therein.

70. The tool of claim 69 wherein a first aperture of a plurality of apertures is configured at an angle to a second aperture of a plurality of apertures.

71. The tool of claim 69 wherein the mold has at least one stabilizer on the surface that engages the joint surface.

72. The tool of claim 70 wherein the stabilizer is selected from the group consisting of pin, peg, post, and nub.

5 73. The tool of claim 65 wherein a surface of the mold that communicates with a surface of the block is configured to prevent at least one movement selected from the group consisting of axial, lateral and rotational.

74. The tool of claim 73 wherein the surface of the block that engages the mold is at least one of convex or concave.

75. The tool of claim 73 wherein the surface of the mold that engages the block is at least one of convex or concave.

10 76. The tool of claim 73 wherein the surface of at least one of the mold and block has an aperture for receiving at least one of a pin, post and peg located on a surface of the mold.

77. The tool of claim 76 wherein the aperture forms a groove providing rotational movement.

15 78. The tool of claim 66 wherein the mold is selected from a library of molds.

79. The tool of claim 65 wherein the mold is patient specific.

80. The tool of claim 65 wherein at least one of the mold and block has a reaming aperture.

20 81. The tool of claim 65 further comprising spacers.

80. The tool of claim 65 wherein block engages the mold in a snap fit.

82. The tool of claim 65 configured to be used in at least one of hip, knee, ankle, shoulder, elbow and wrist.

83. The tool of claim 65 configured to be used in a joint in the body.

25 84. A method of placing an implant into a joint, the method comprising the steps of imaging the joint using a C-arm system, obtaining a cross-sectional

image with the C-arm system, and utilizing the image for placing the implant into a joint.

85. The method of claim 84 further comprising the step of obtaining a partial rotation with the C-arm system.

5 86. A tool formed at least partially in situ comprising:
a mold formed in situ using at least one of an inflatable hollow device or a retaining device to conform to the joint surface on at least one surface having a surface for engaging a joint surface;
a block that communicates with the mold; and
10 at least one guide aperture in the block.

87. The tool of claim 86 wherein the mold has at least one aperture positioned below the at least one guide aperture in the block.

88. The tool of claim 86 wherein the mold and the block have a plurality of guide apertures therein.

15 89. The tool of claim 88 wherein a first aperture of a plurality of guide apertures is configured at an angle to a second aperture of a plurality of guide apertures.

90. The tool of claim 88 wherein the mold has at least one stabilizer on the surface that engages the joint surface.

20 91. The tool of claim 79 wherein the stabilizer is selected from the group consisting of pin, peg, post, and nub.

92. The tool of claim 86 wherein a surface of the mold that communicates with a surface of the block is configured to prevent at least one movement selected from the group consisting of axial, lateral and rotational.

25 93. The tool of claim 92 wherein the surface of the block that engages the mold is at least one of convex or concave.

94. The tool of claim 92 wherein the surface of the mold that engages the block is at least one of convex or concave.

95. The tool of claim 92 wherein the surface of at least one of the mold and block has an aperture for receiving at least one of a pin, post and peg located on a surface of the mold.

96. The tool of claim 95 wherein the aperture forms a groove providing rotational movement.

97. The tool of claim 86 wherein the mold patient specific.

98. The tool of claim 86 wherein at least one of the mold and block has a reaming aperture.

99. The tool of claim 99 further comprising spacers.

100. The tool of claim 86 wherein block engages the mold in a snap fit.

101. The tool of claim 86 configured to be used in at least one of hip, knee, ankle, shoulder, elbow and wrist.

102. The tool of claim 86 configured to be used in a joint in the body.

1 / 36

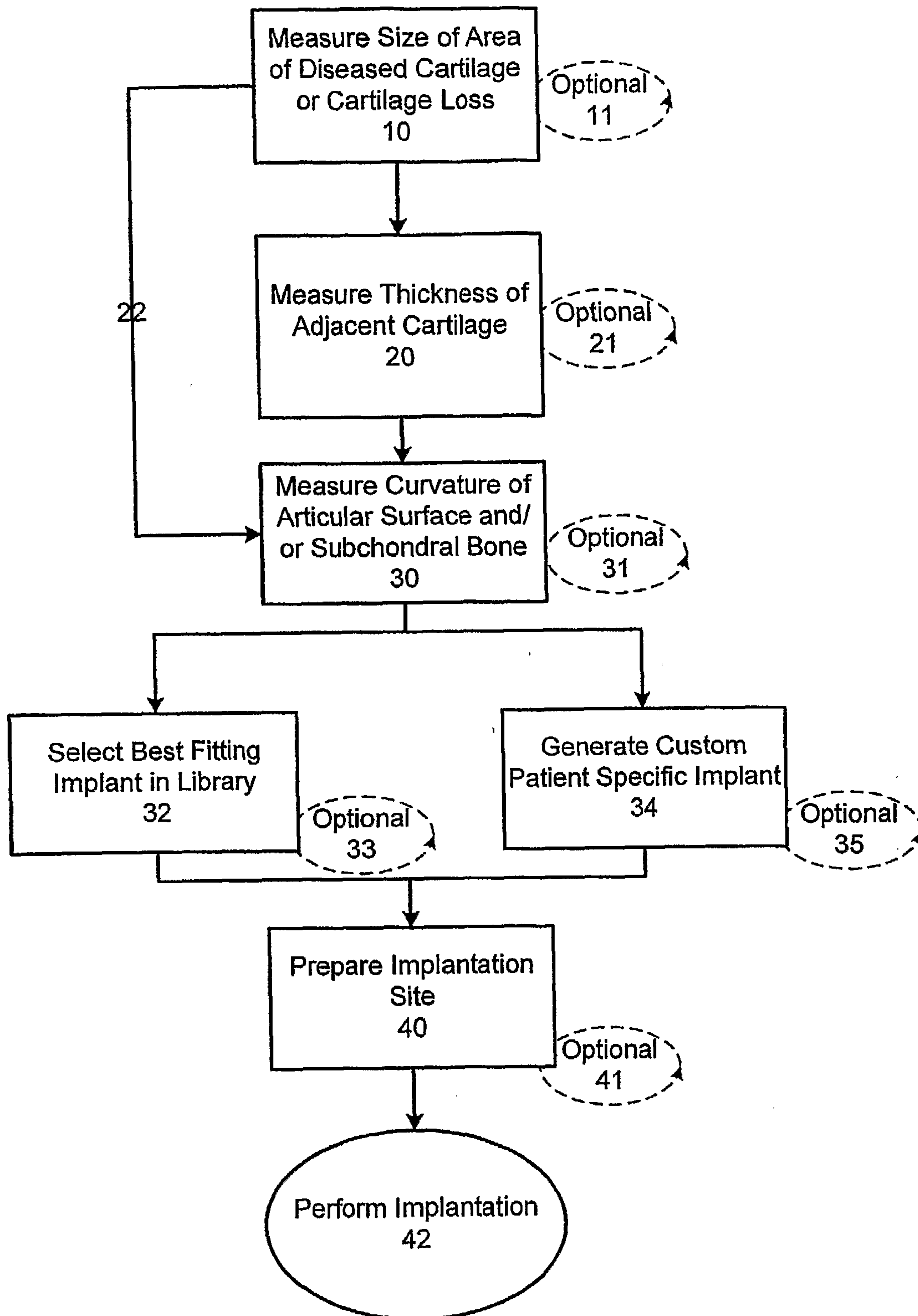
**FIG. 1**

2 / 36

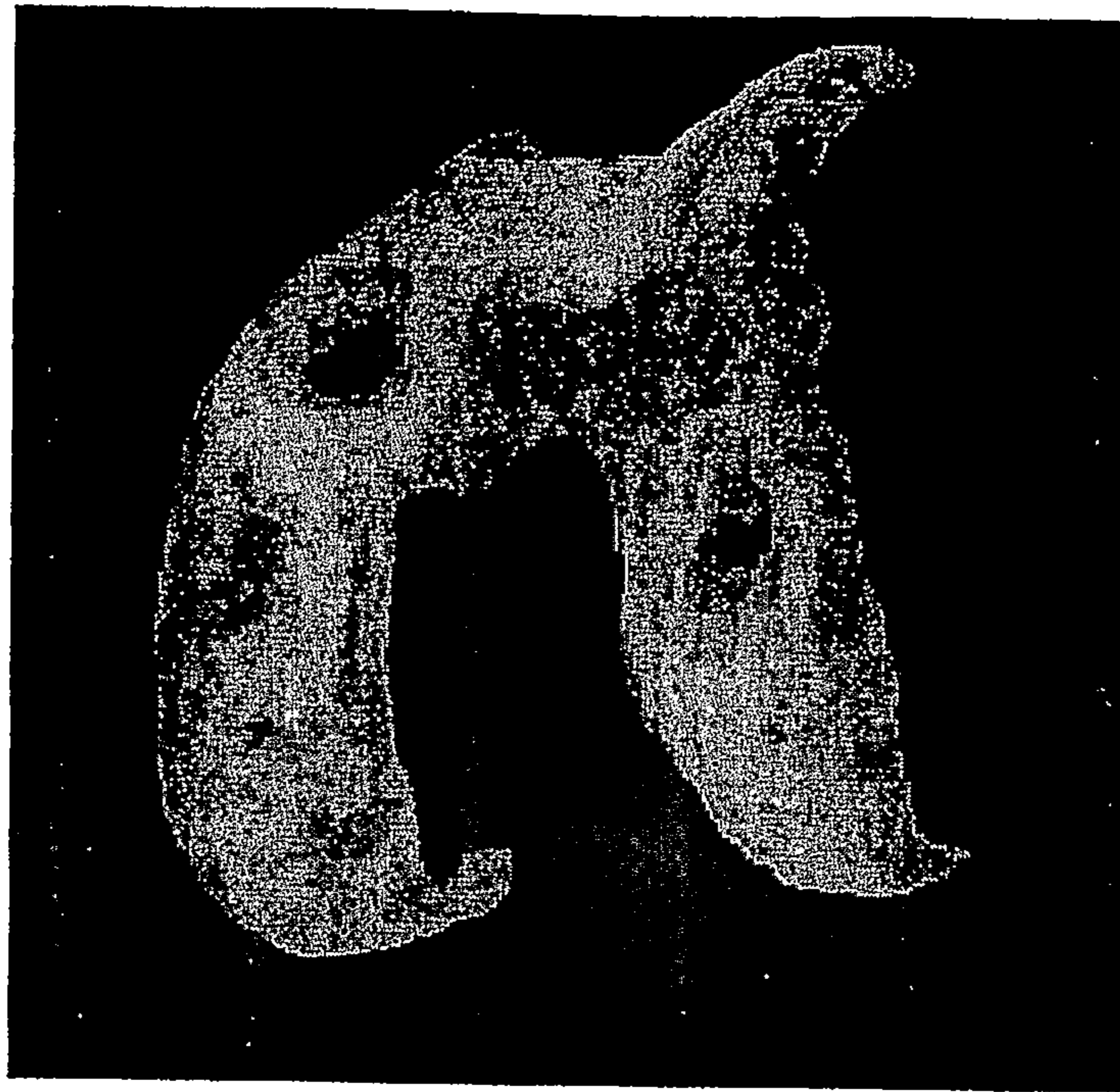

FIG. 2

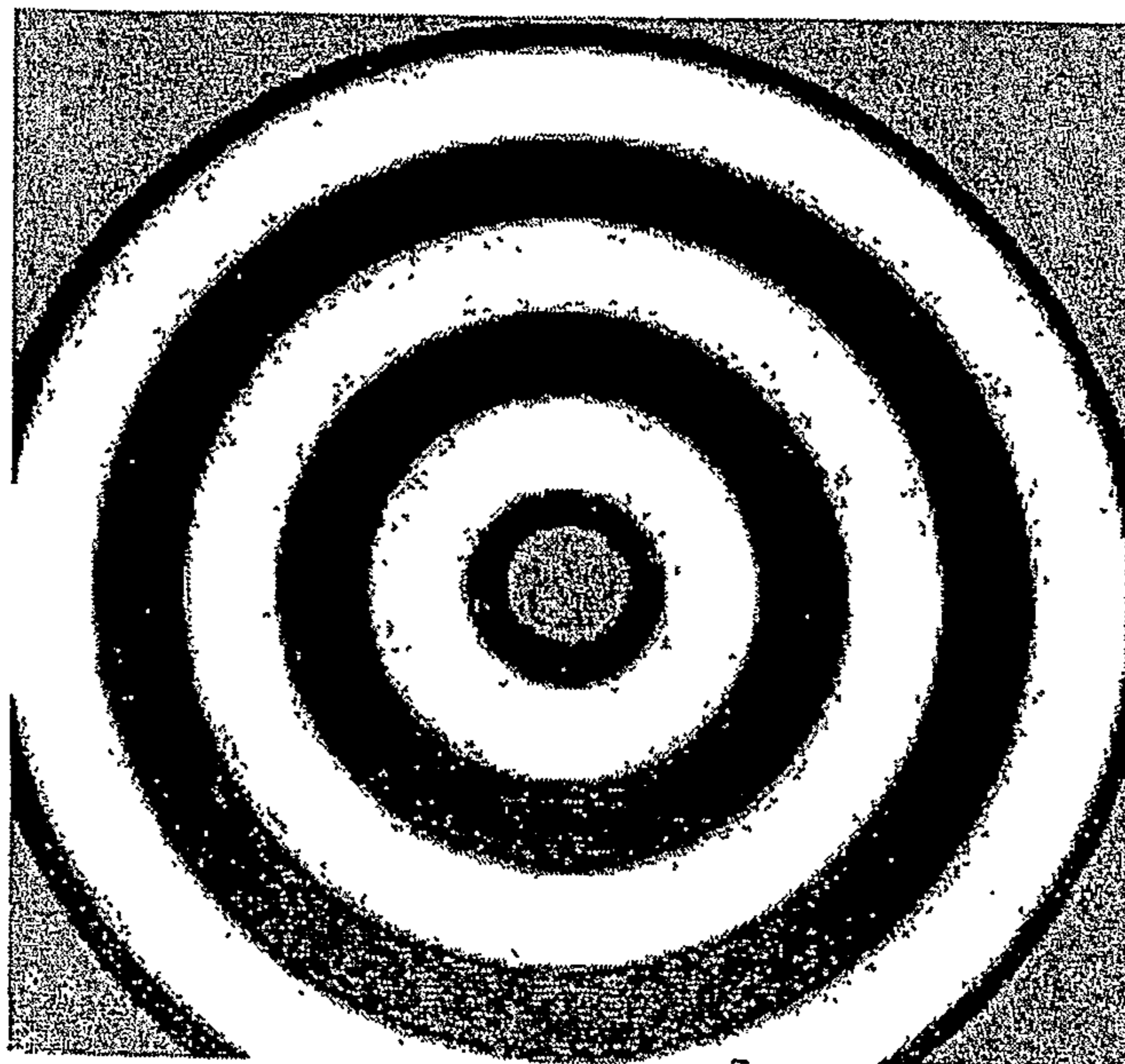

FIG. 3A

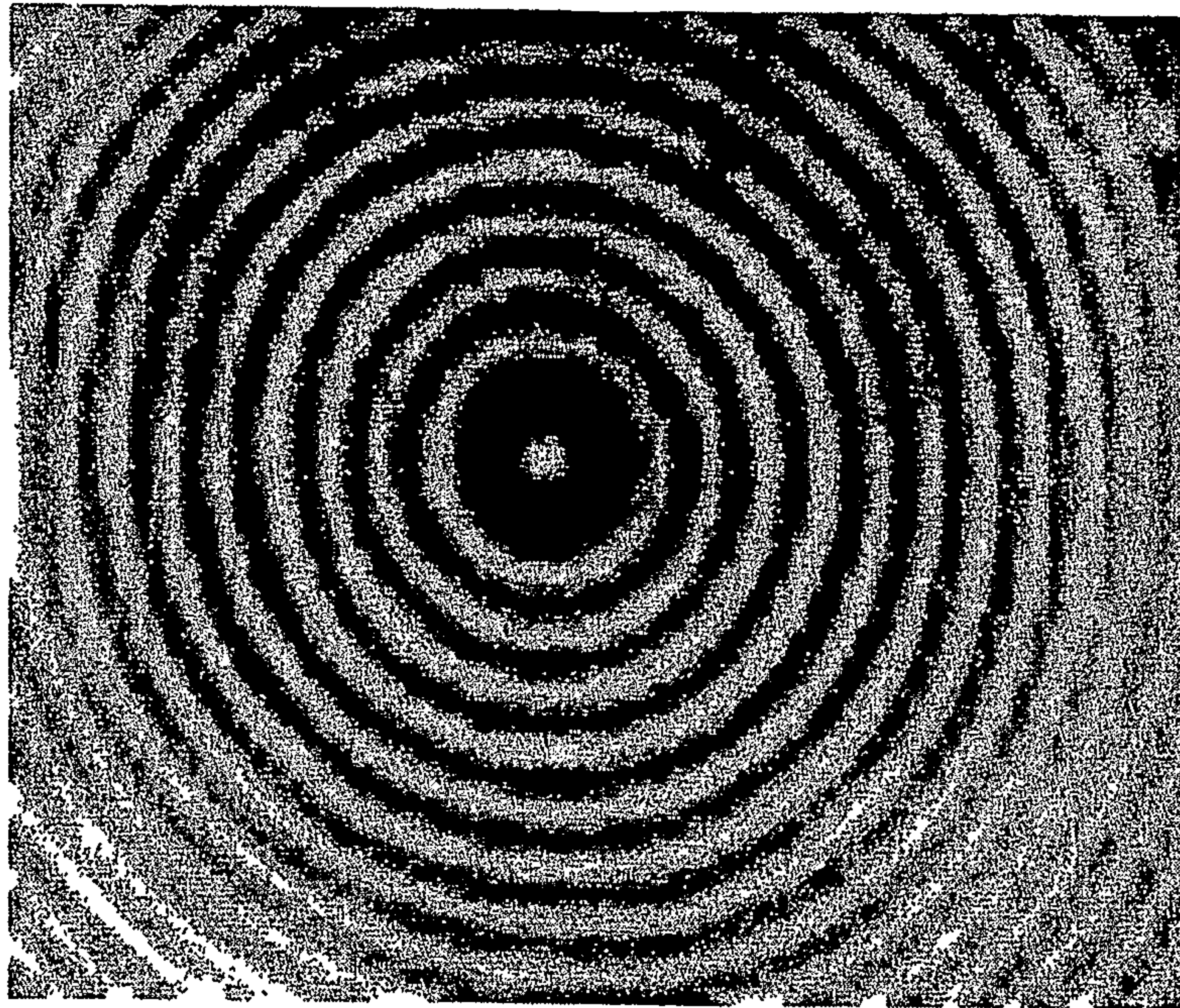

FIG. 3B

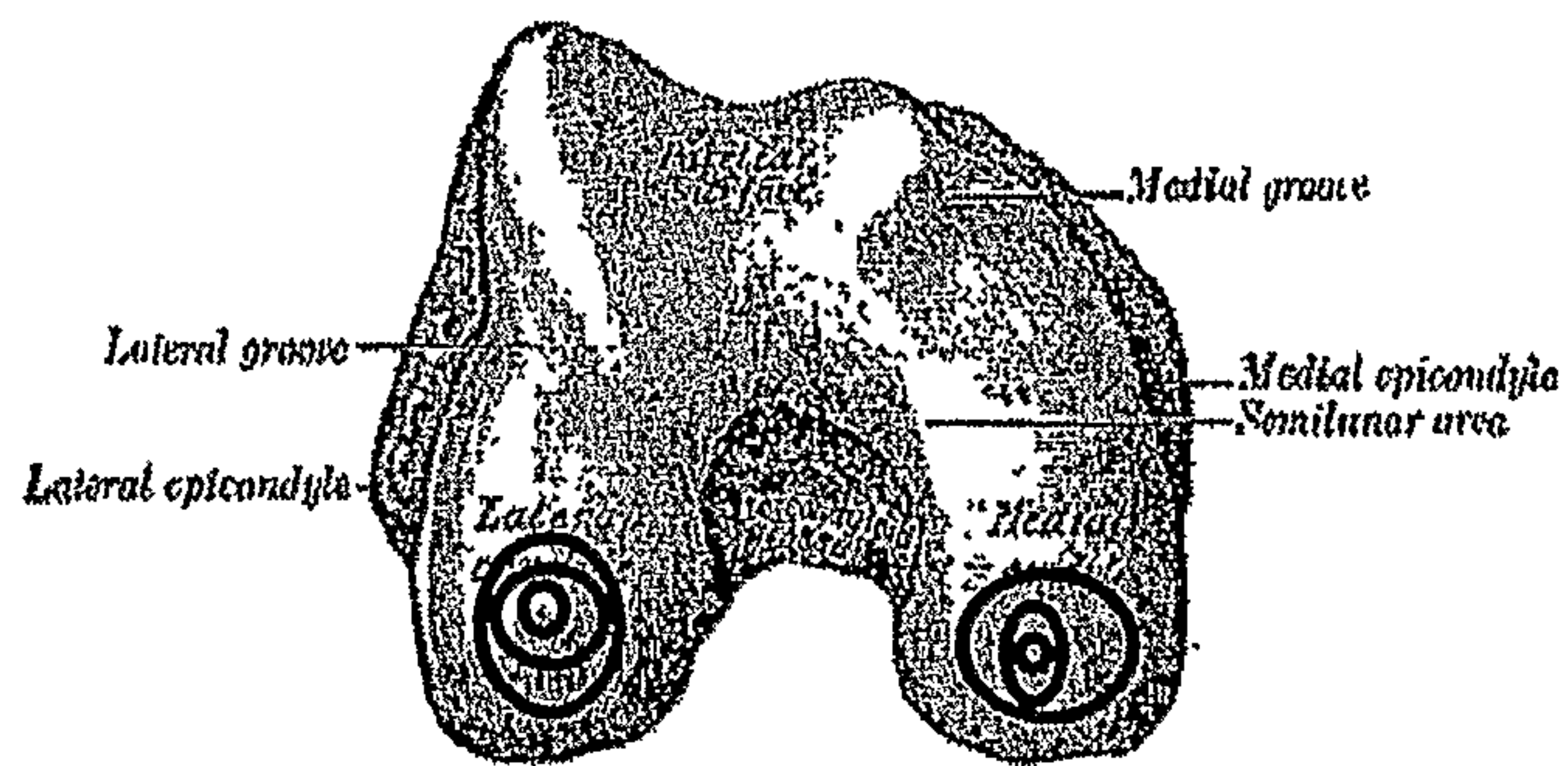

FIG. 4

4 / 36

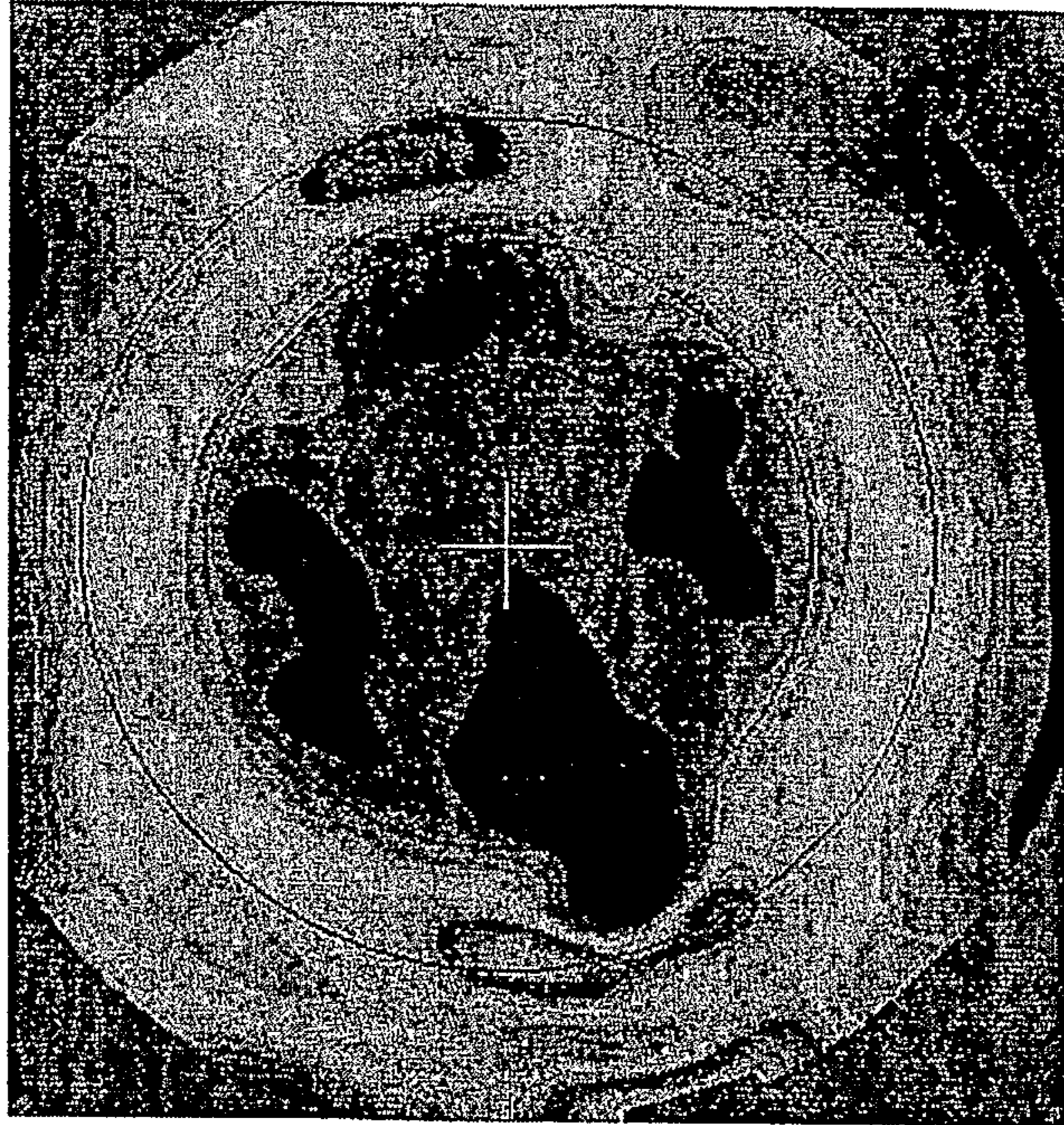

FIG. 5

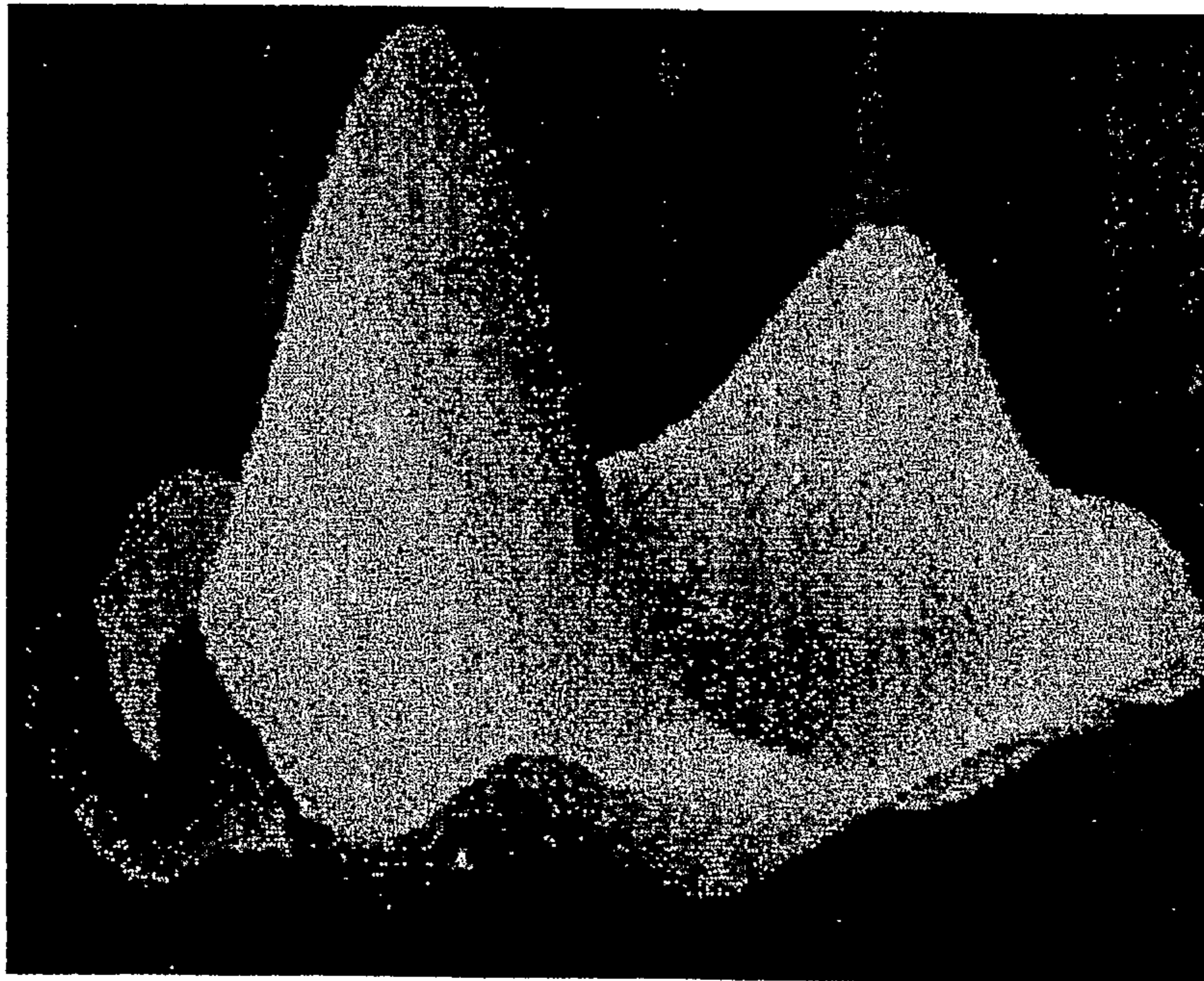

FIG. 6

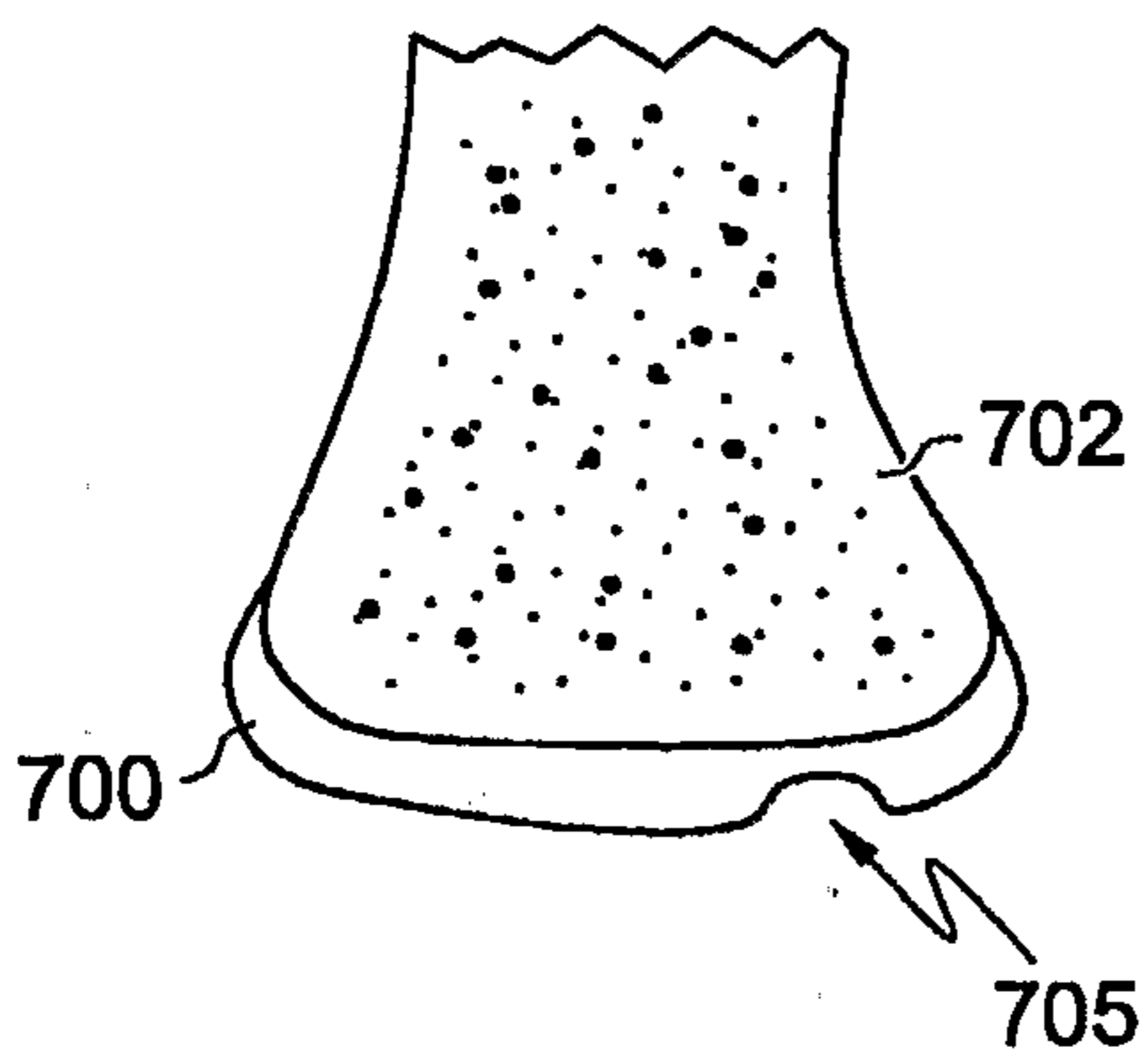

FIG. 7A

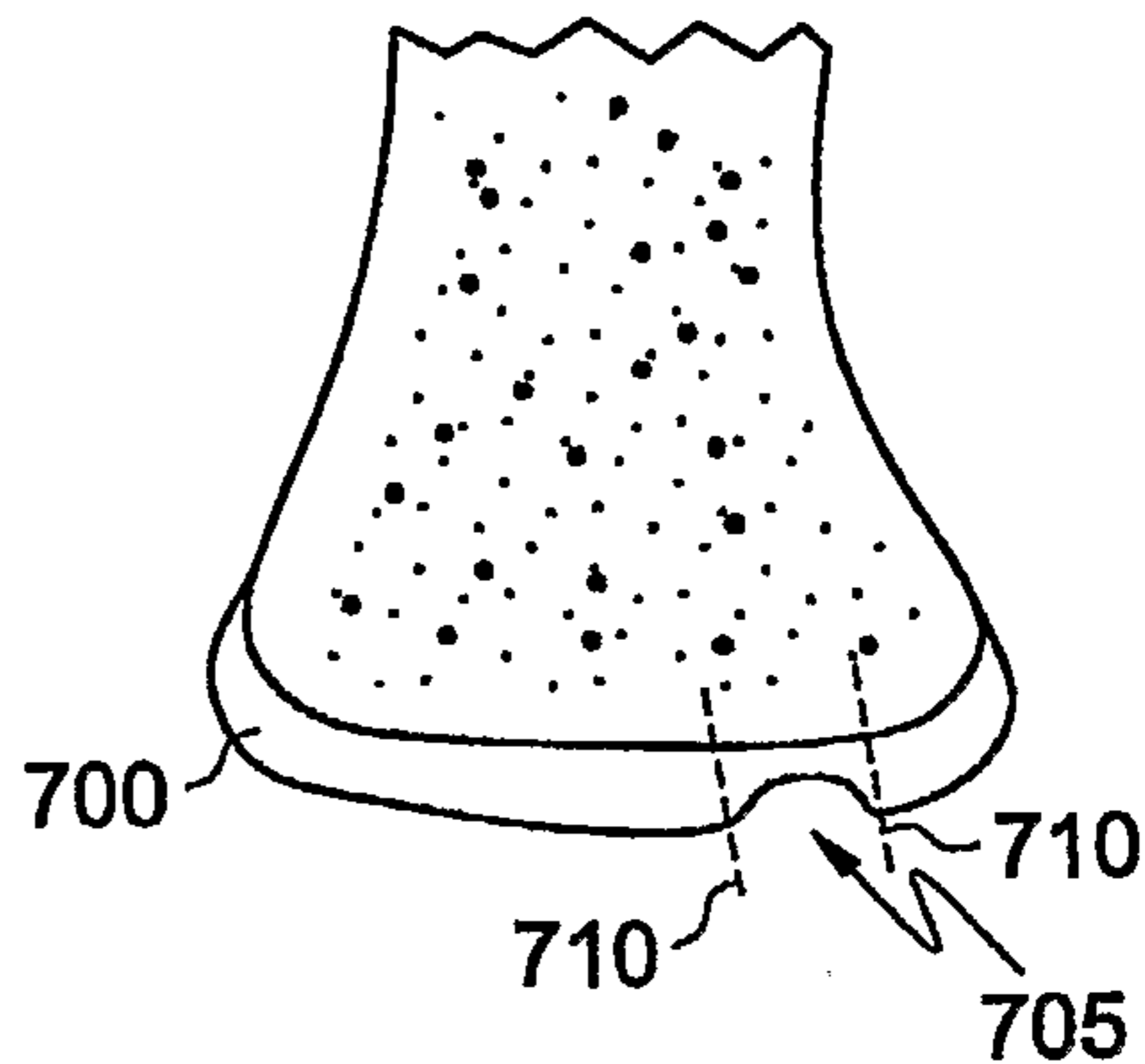

FIG. 7B

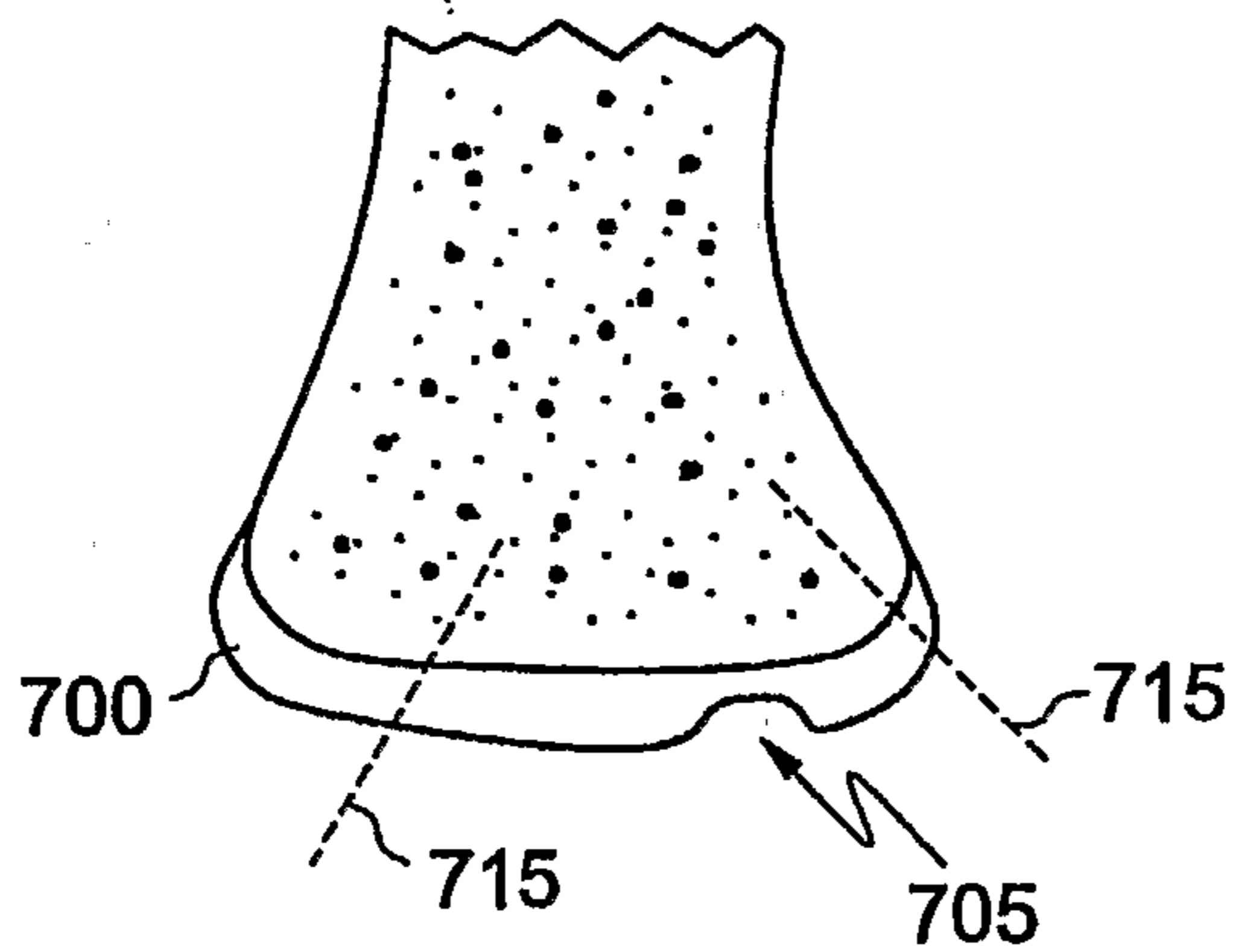

FIG. 7C

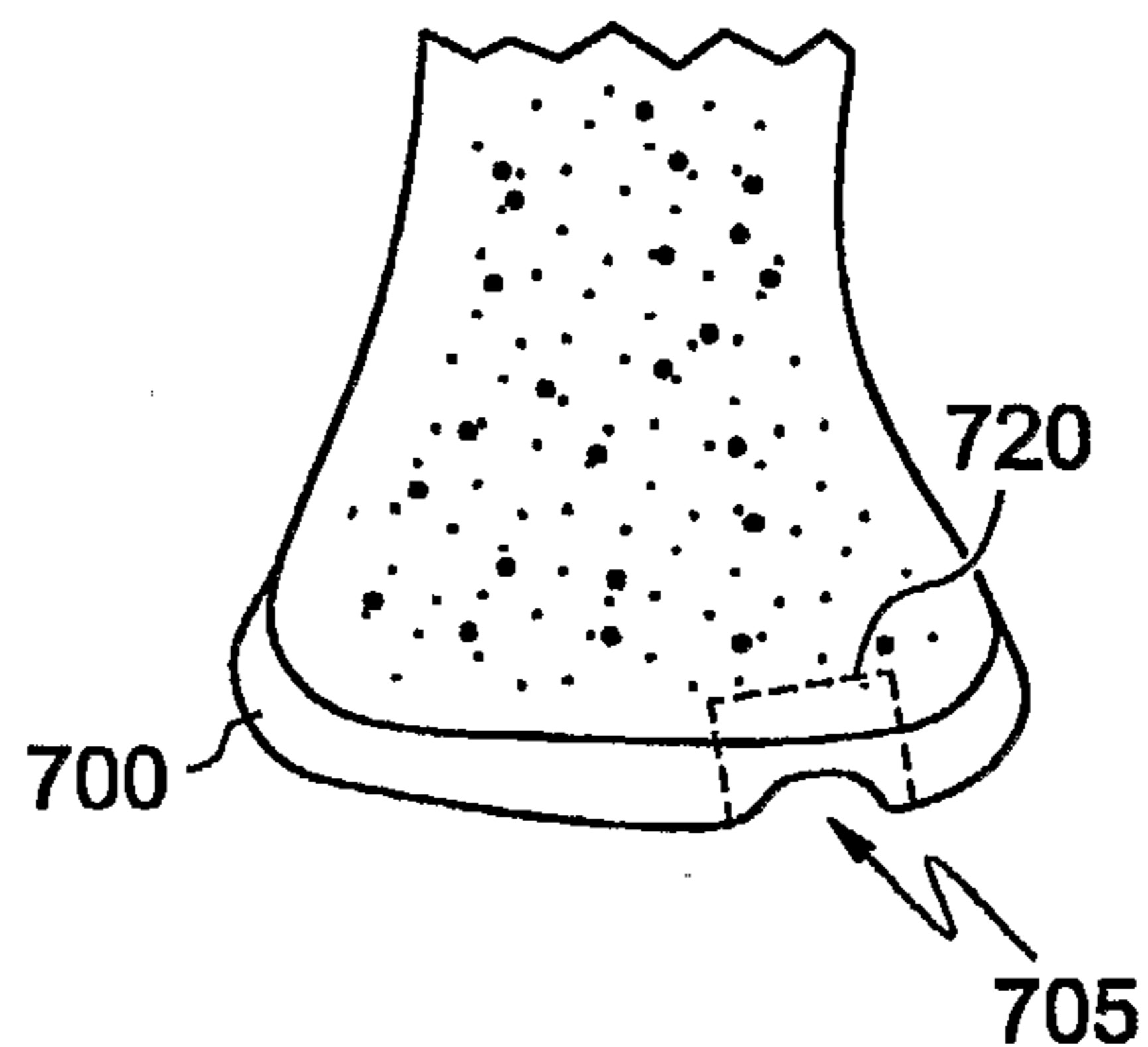

FIG. 7D

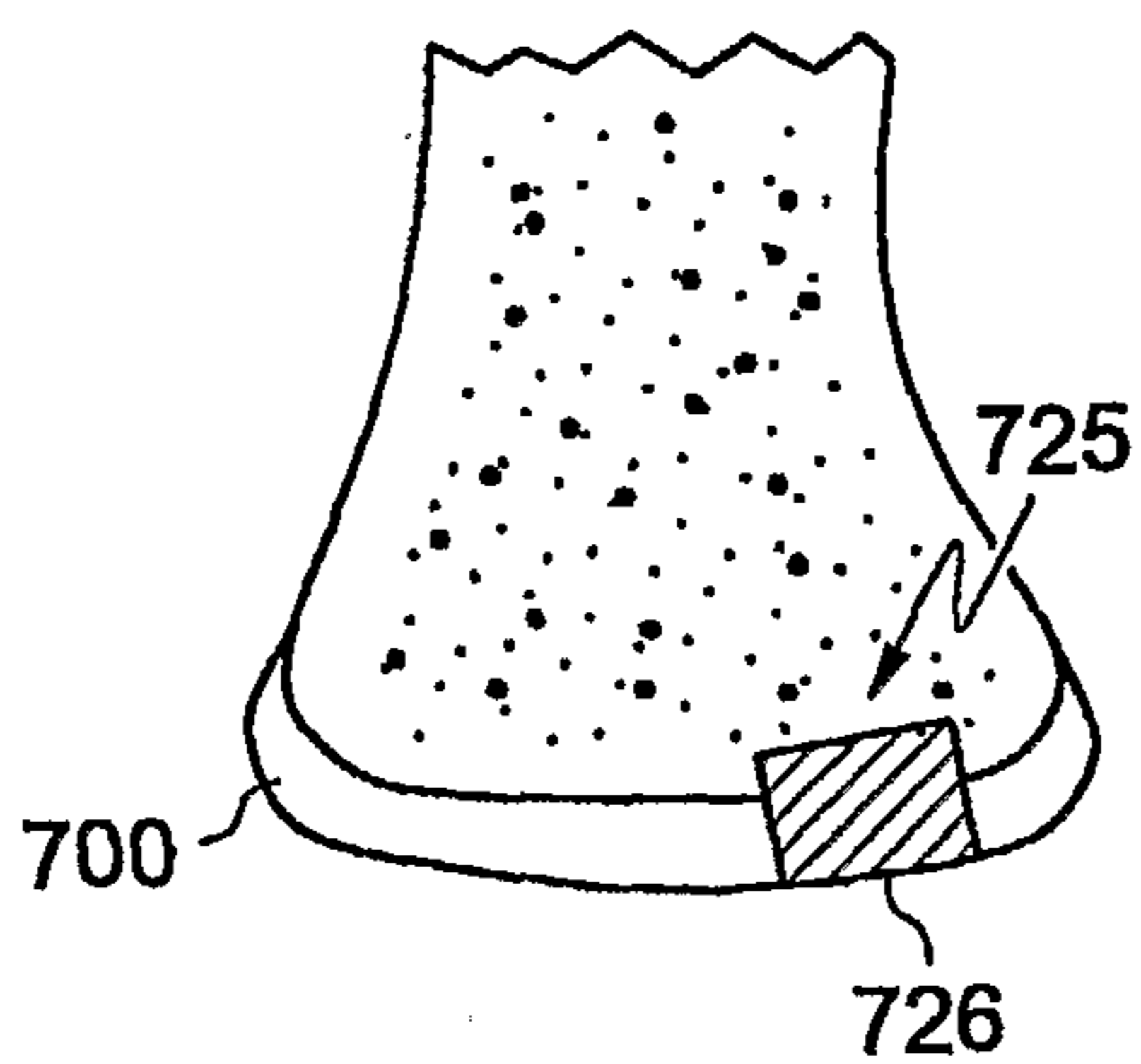

FIG. 7E

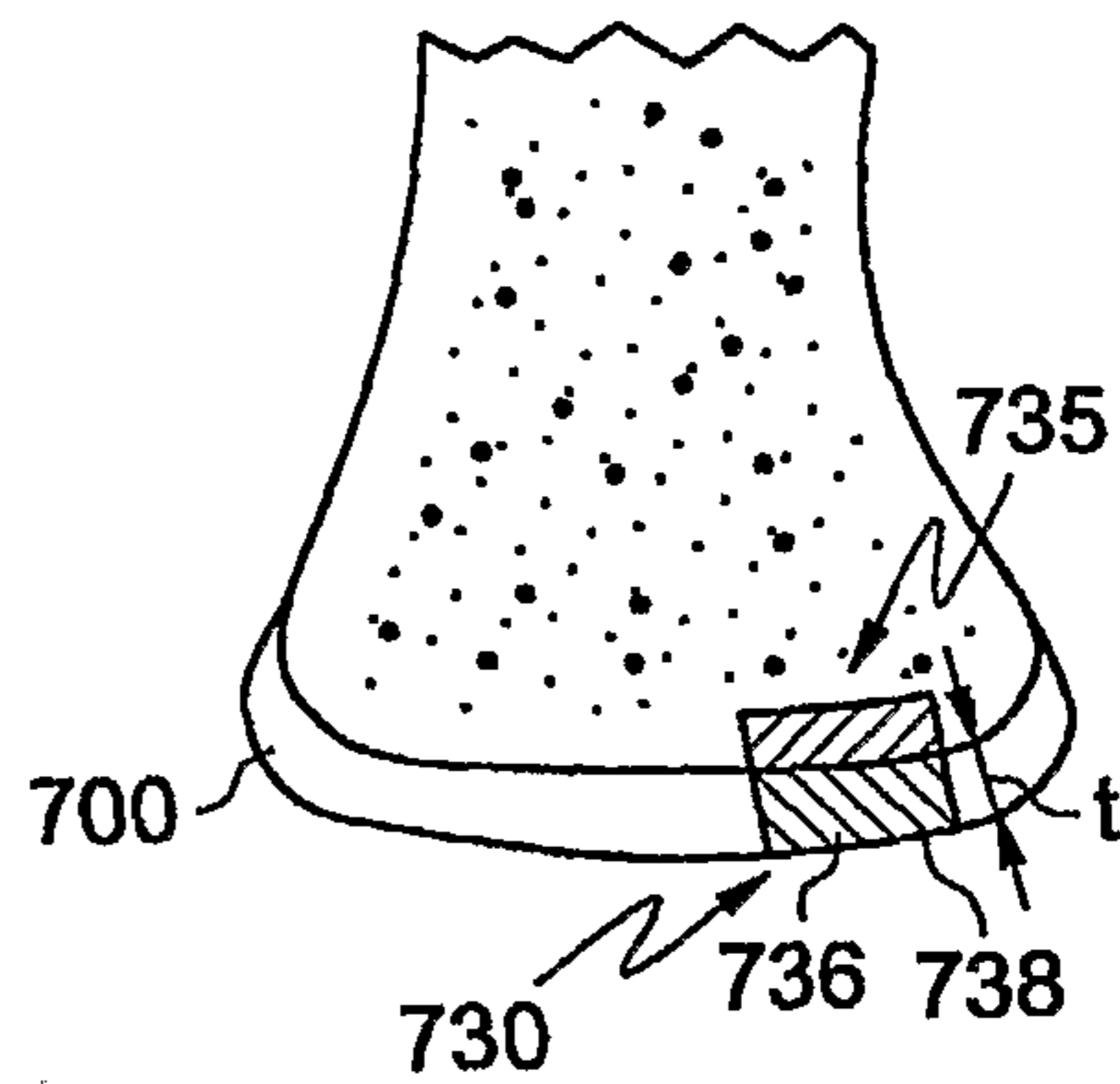

FIG. 7F

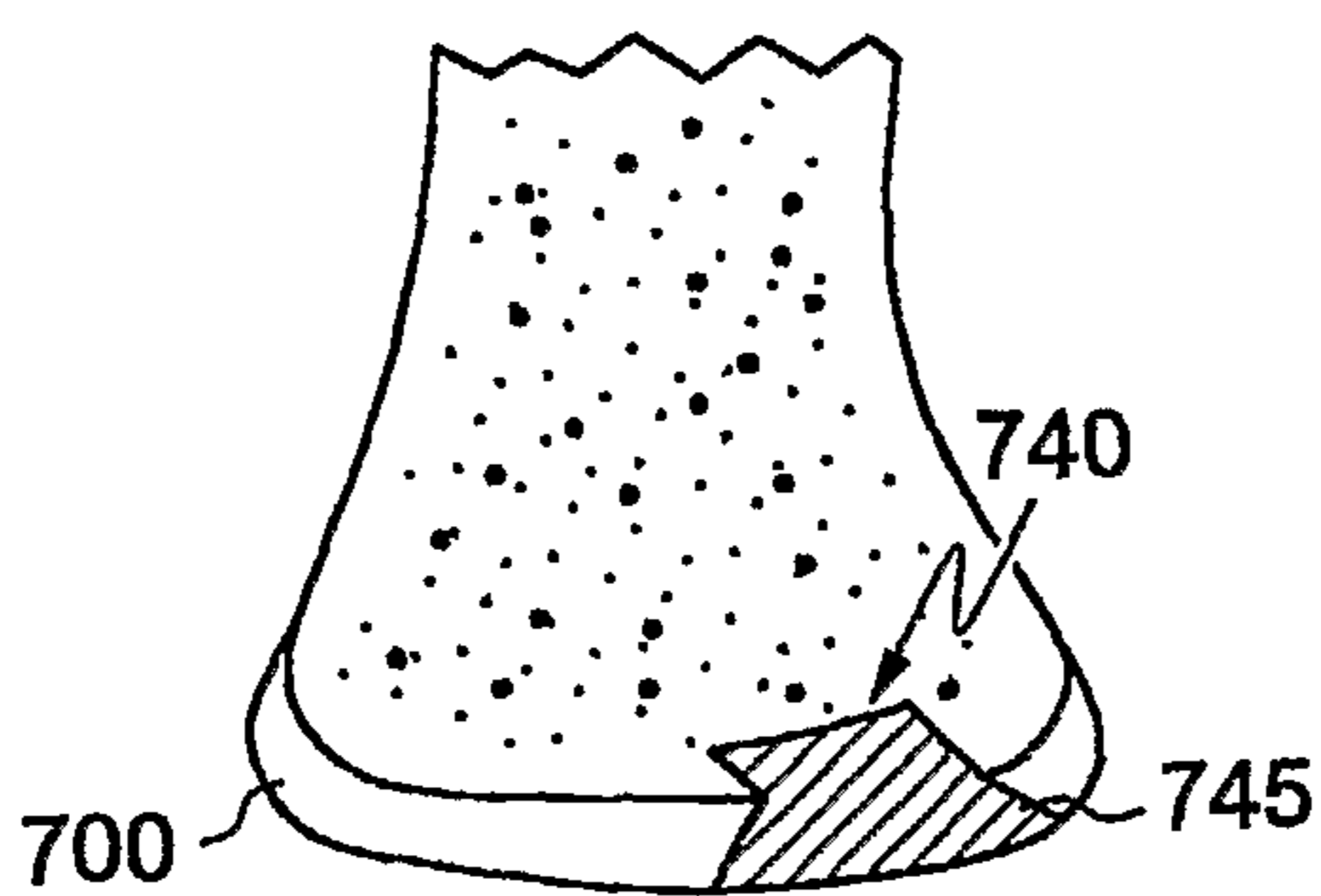

FIG. 7G

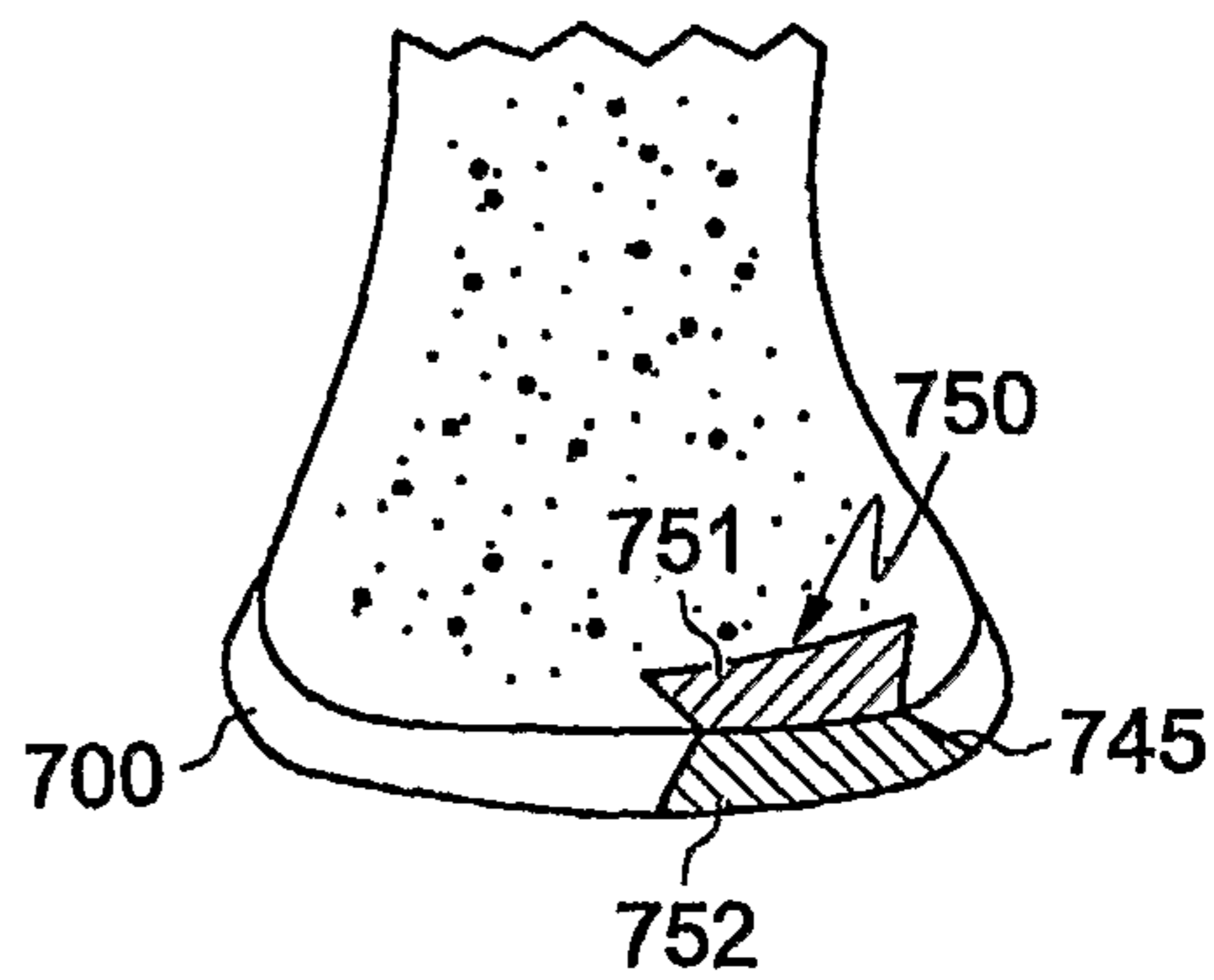

FIG. 7H

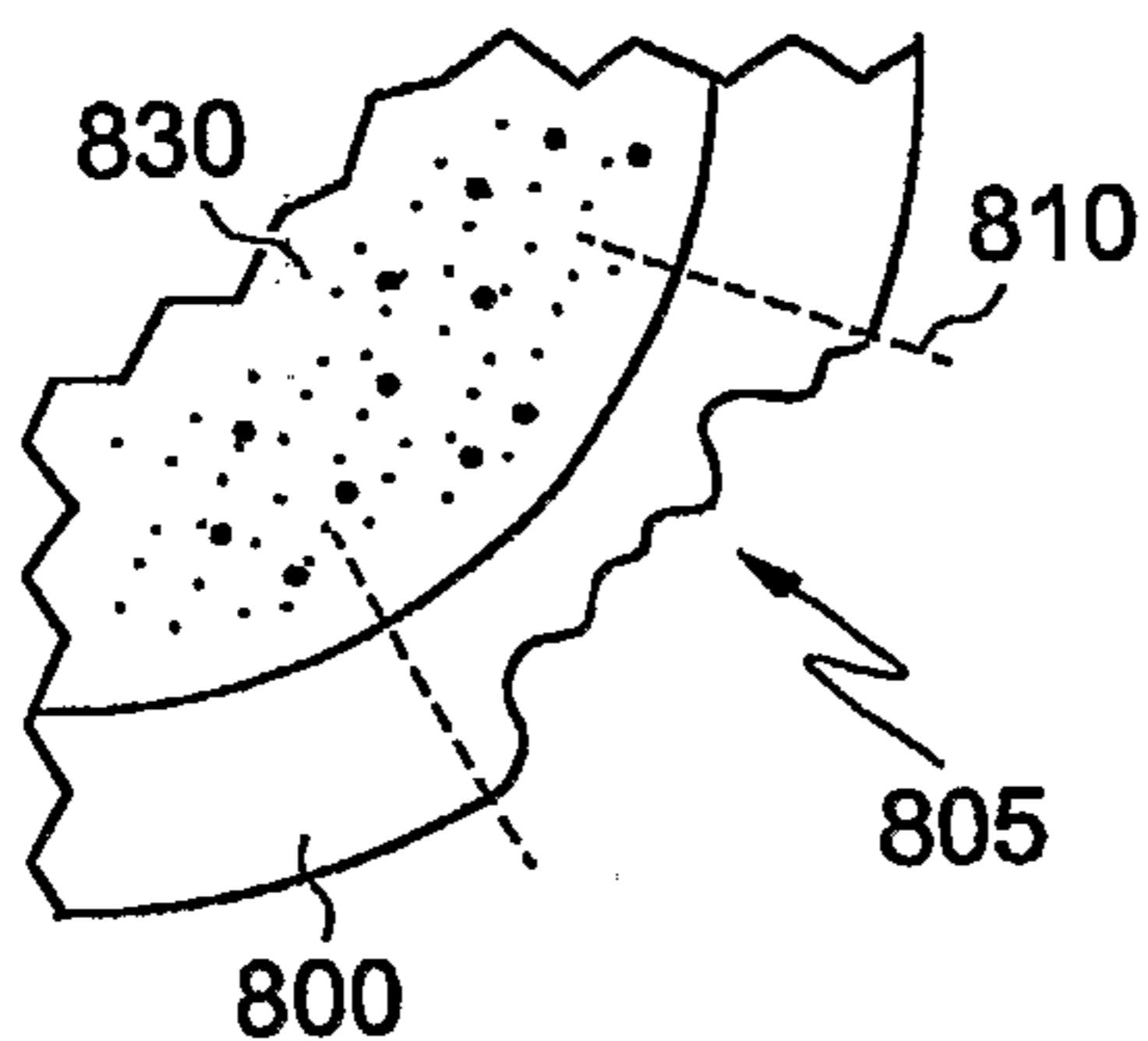

FIG. 8A

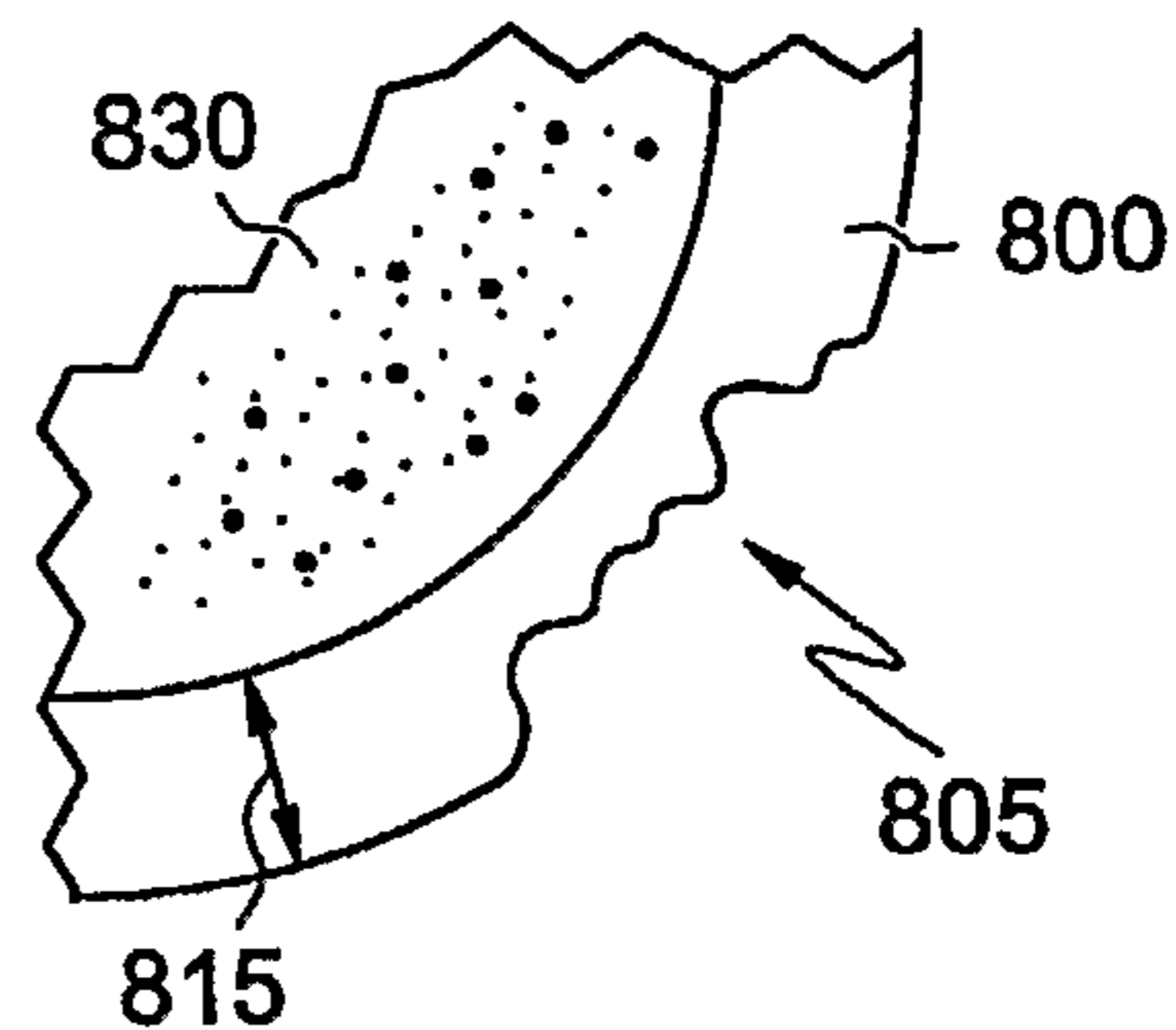

FIG. 8B

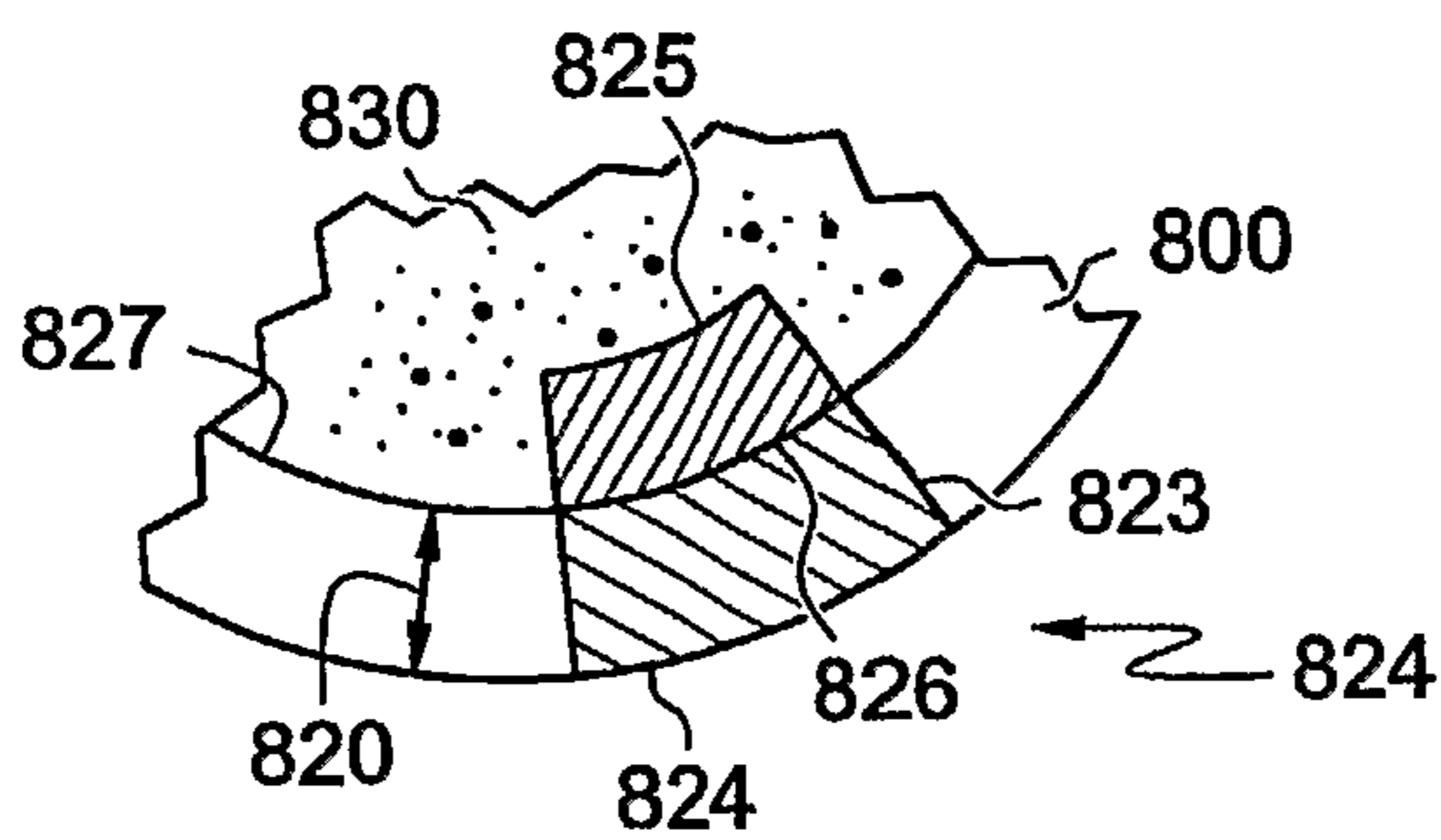

FIG. 8C

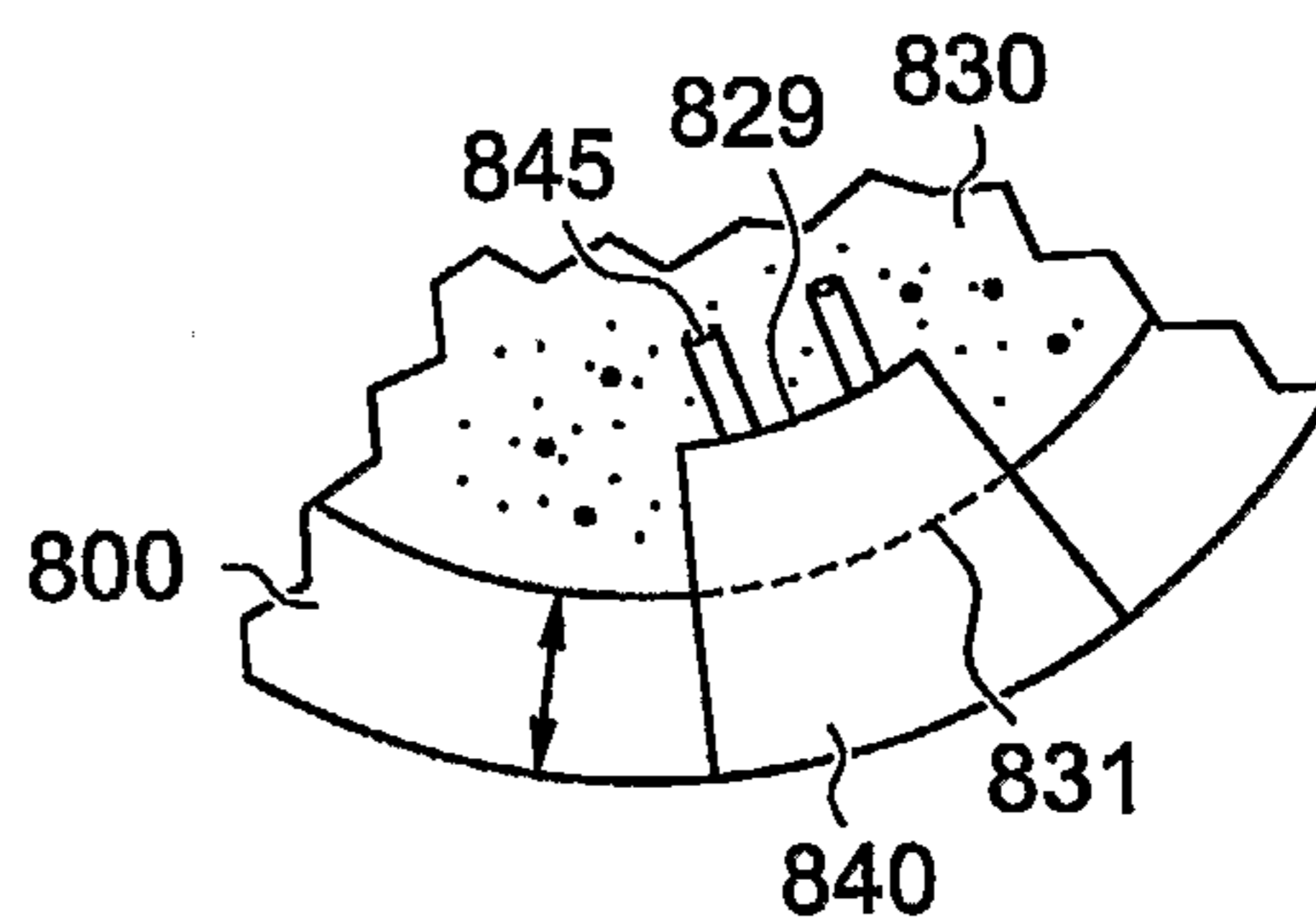

FIG. 8D

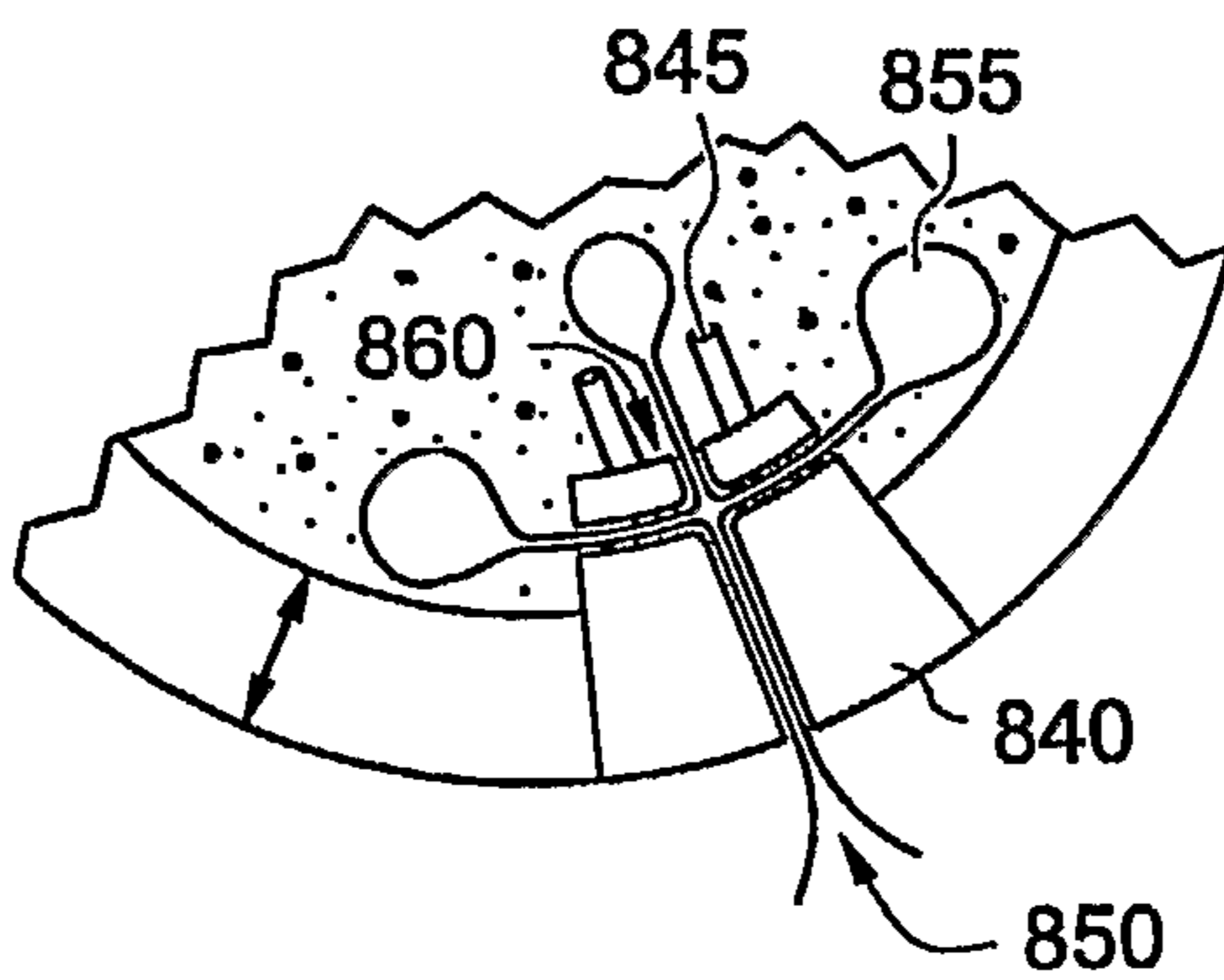

FIG. 8E

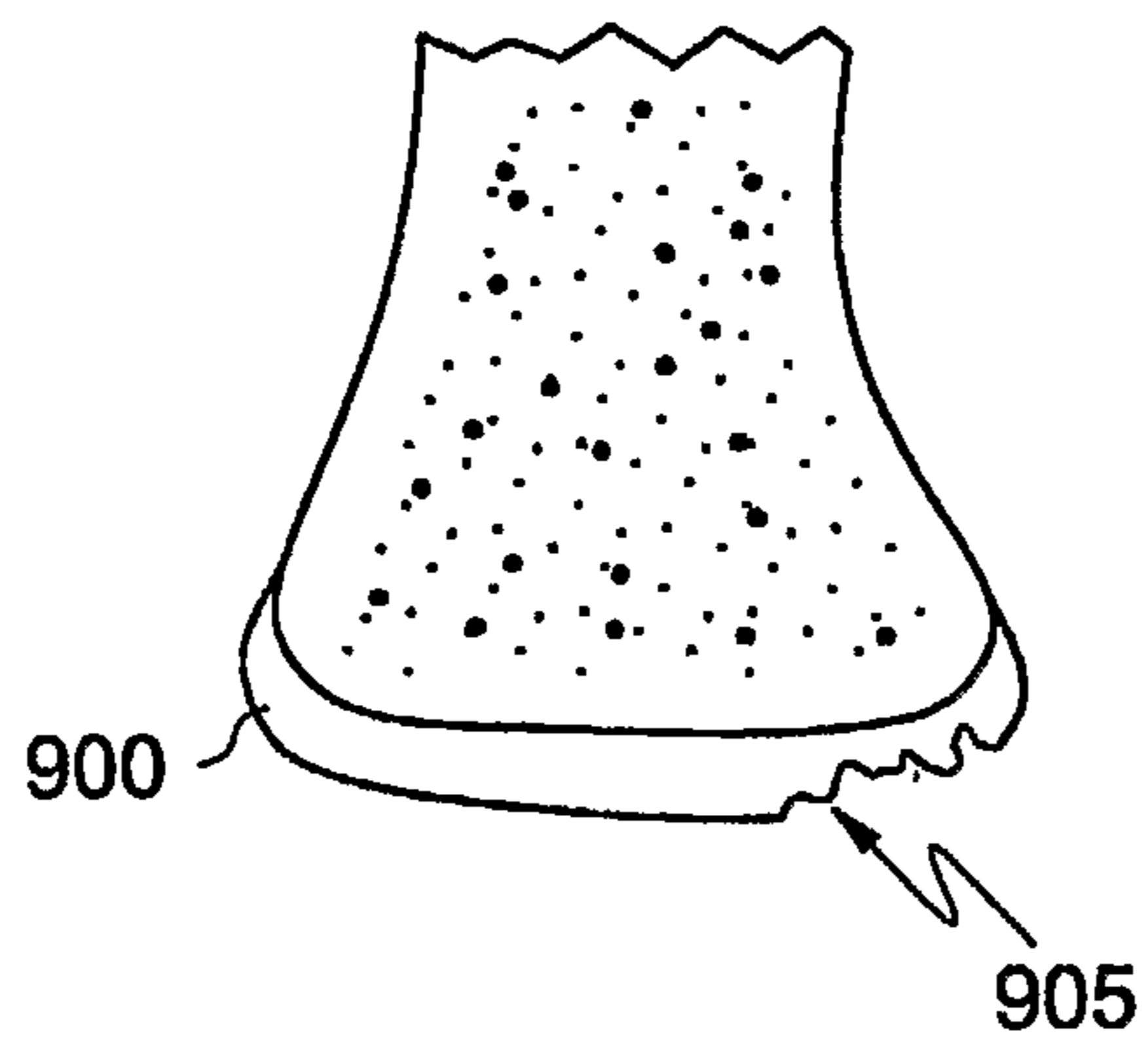

FIG. 9A

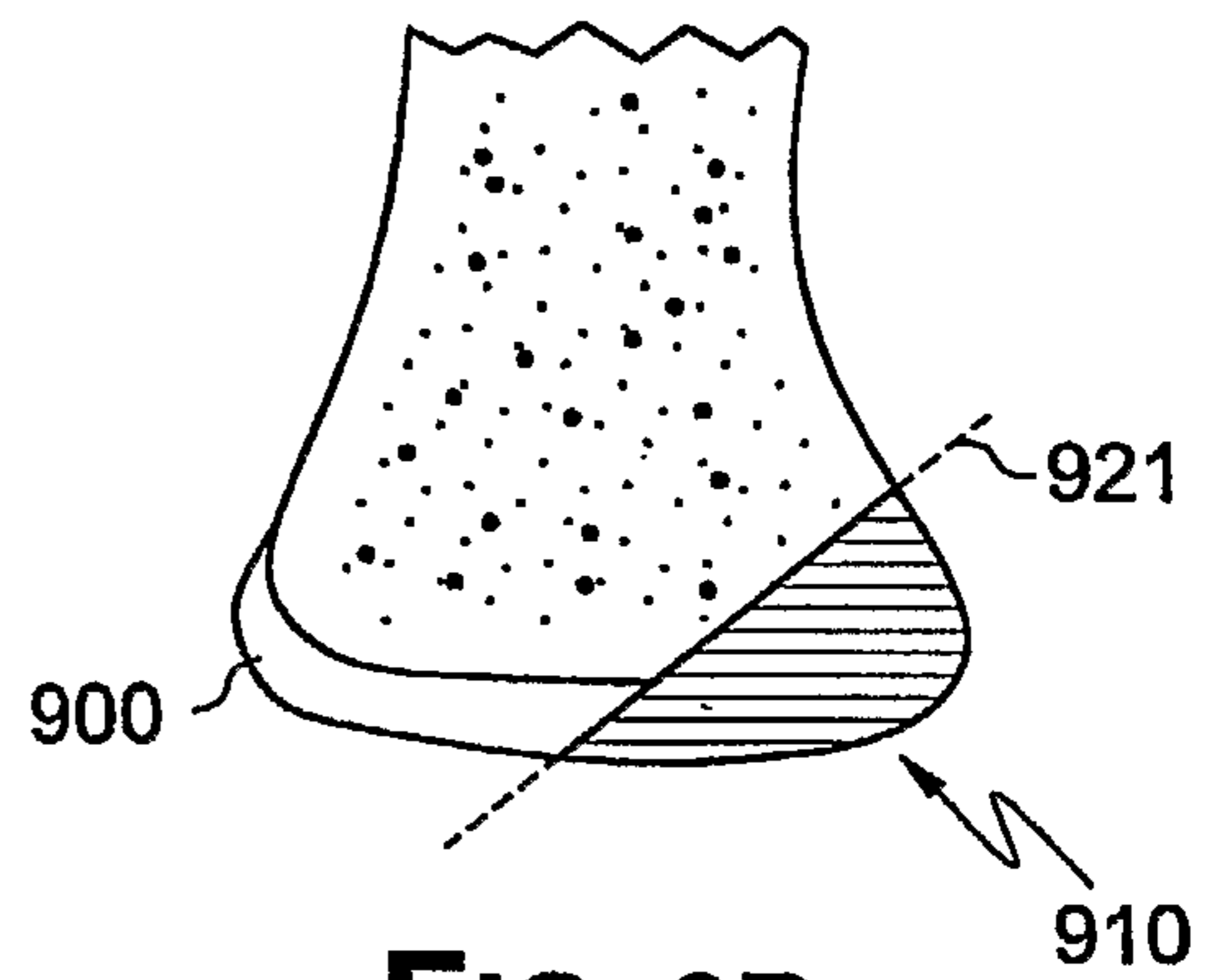

FIG. 9B

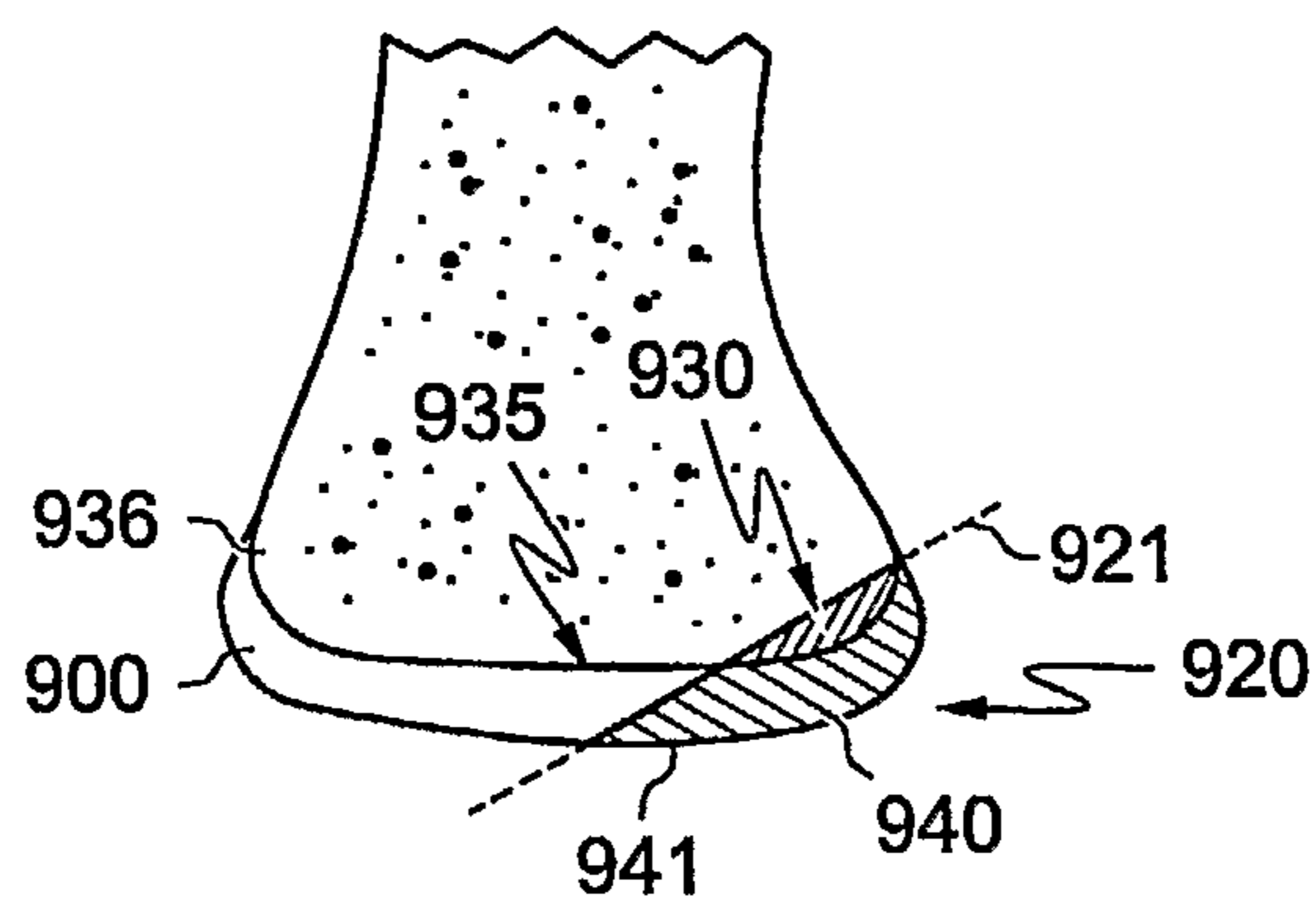

FIG. 9C

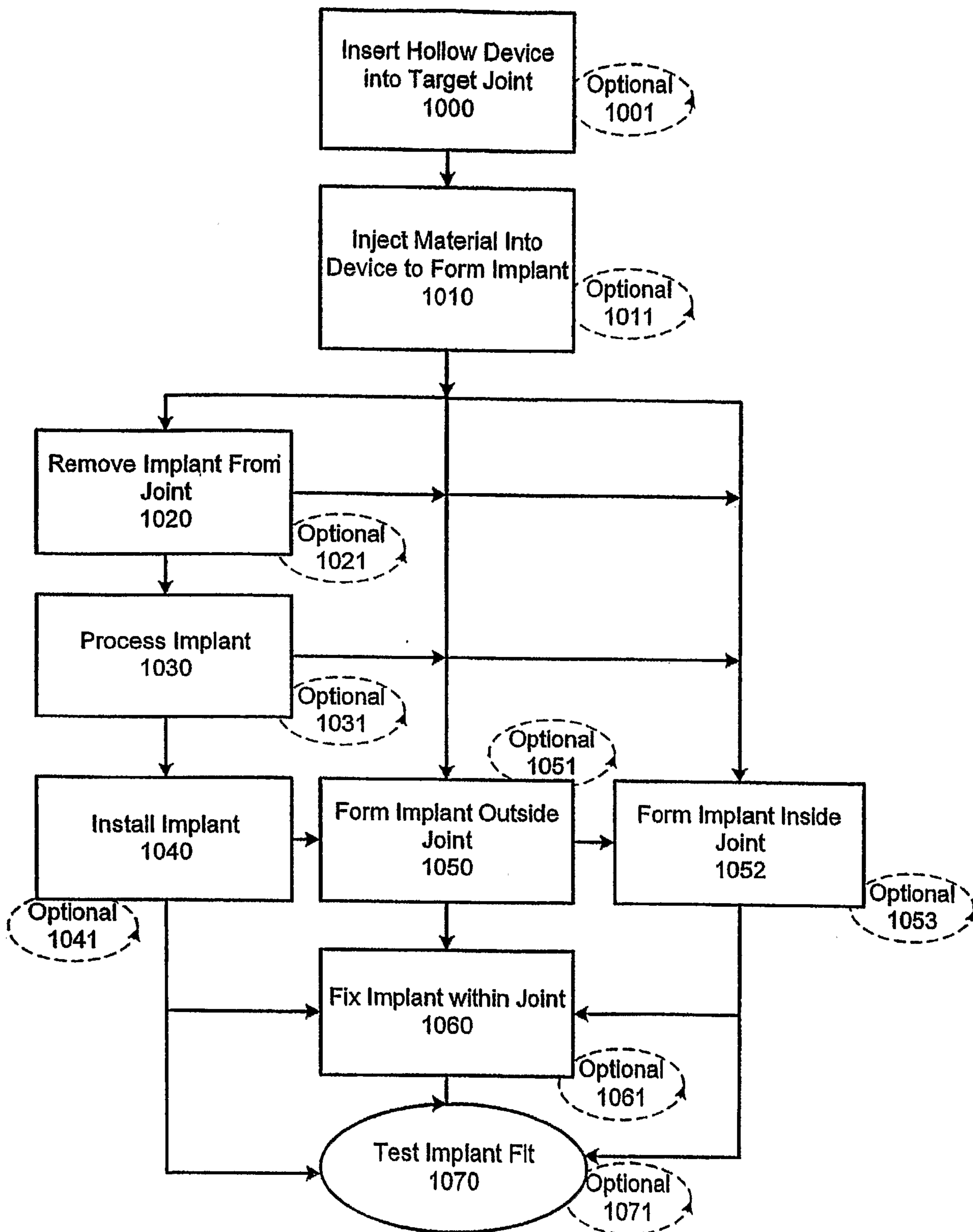

FIG. 10A

10 / 36

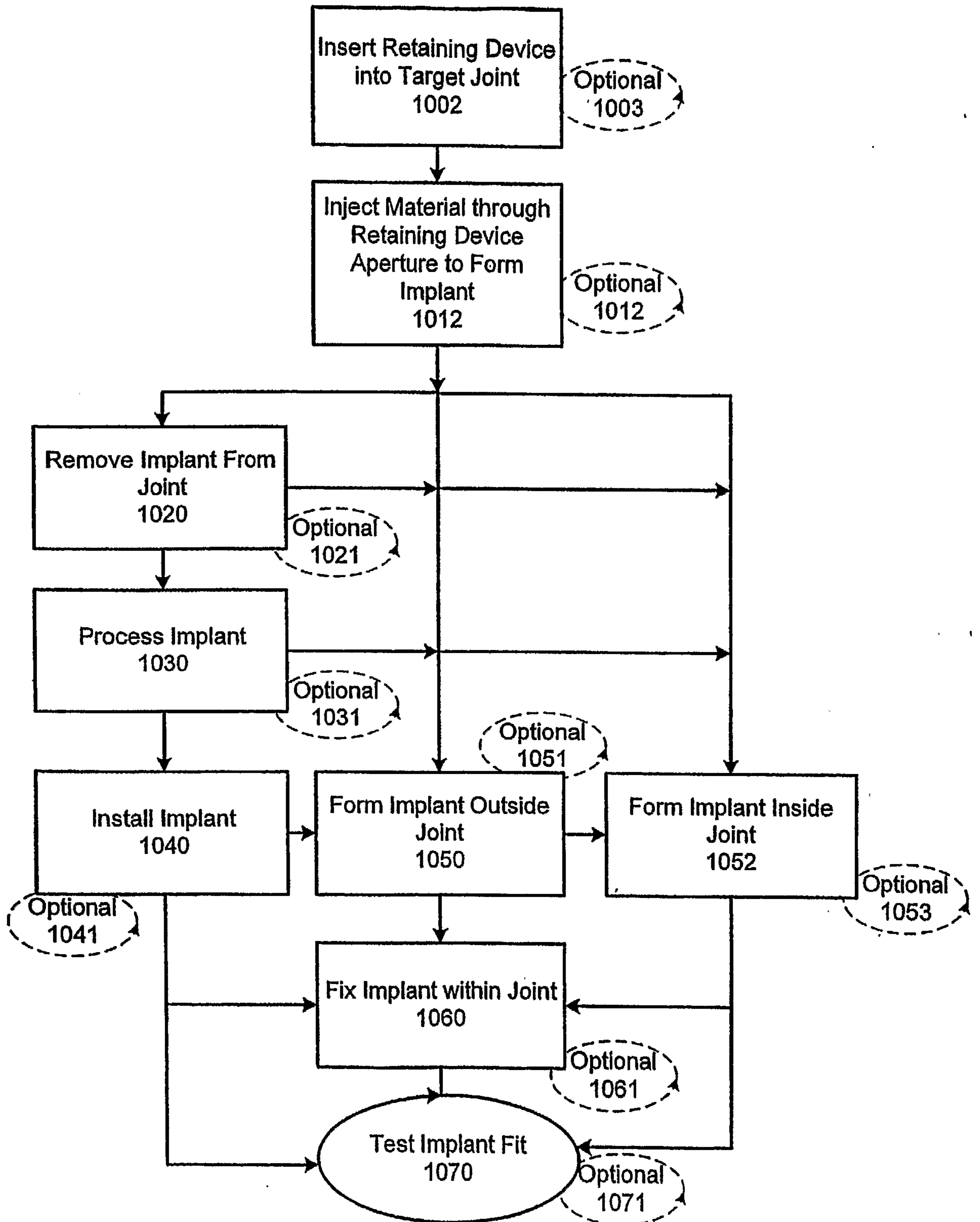

FIG. 10B

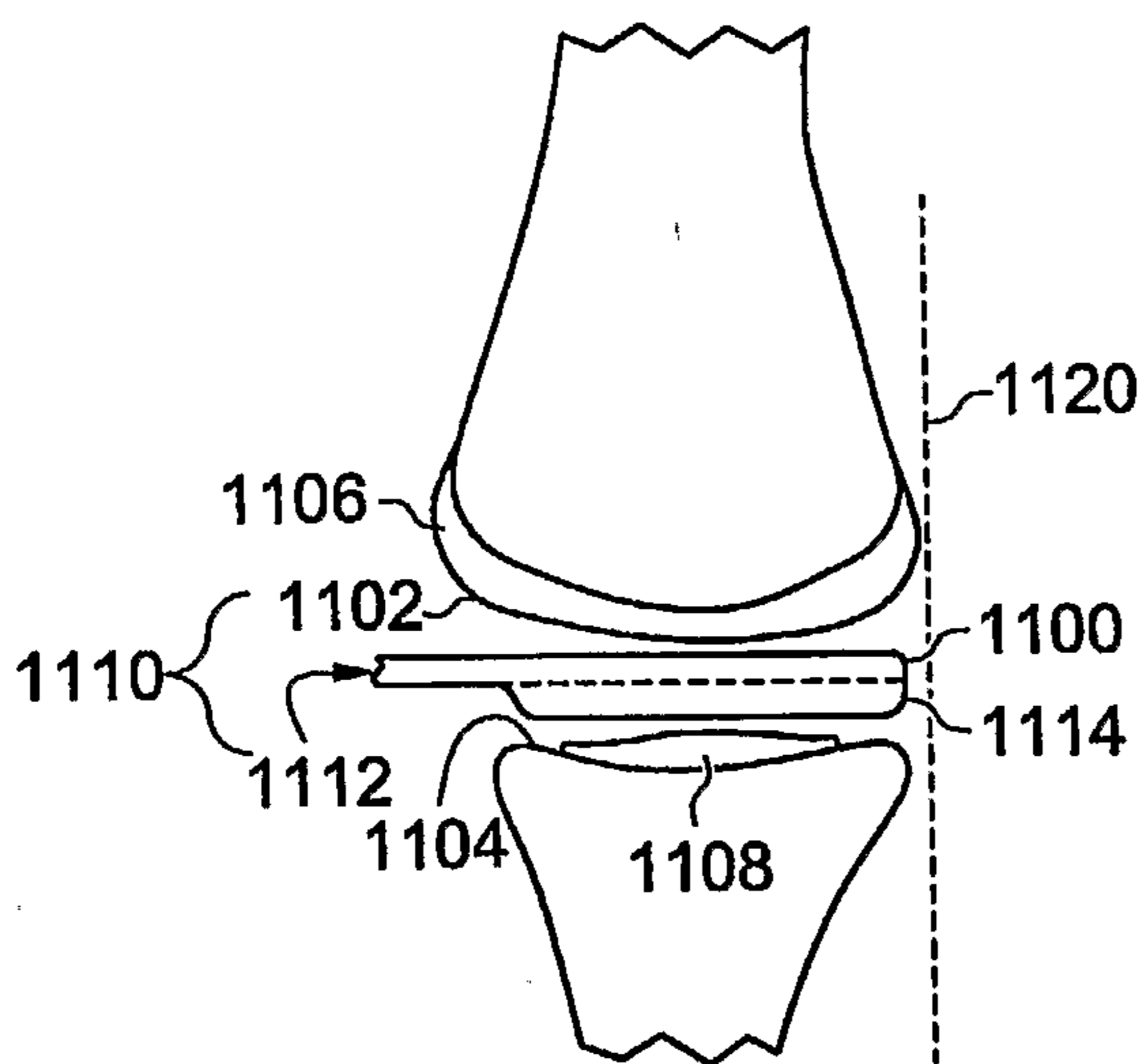

FIG. 11A

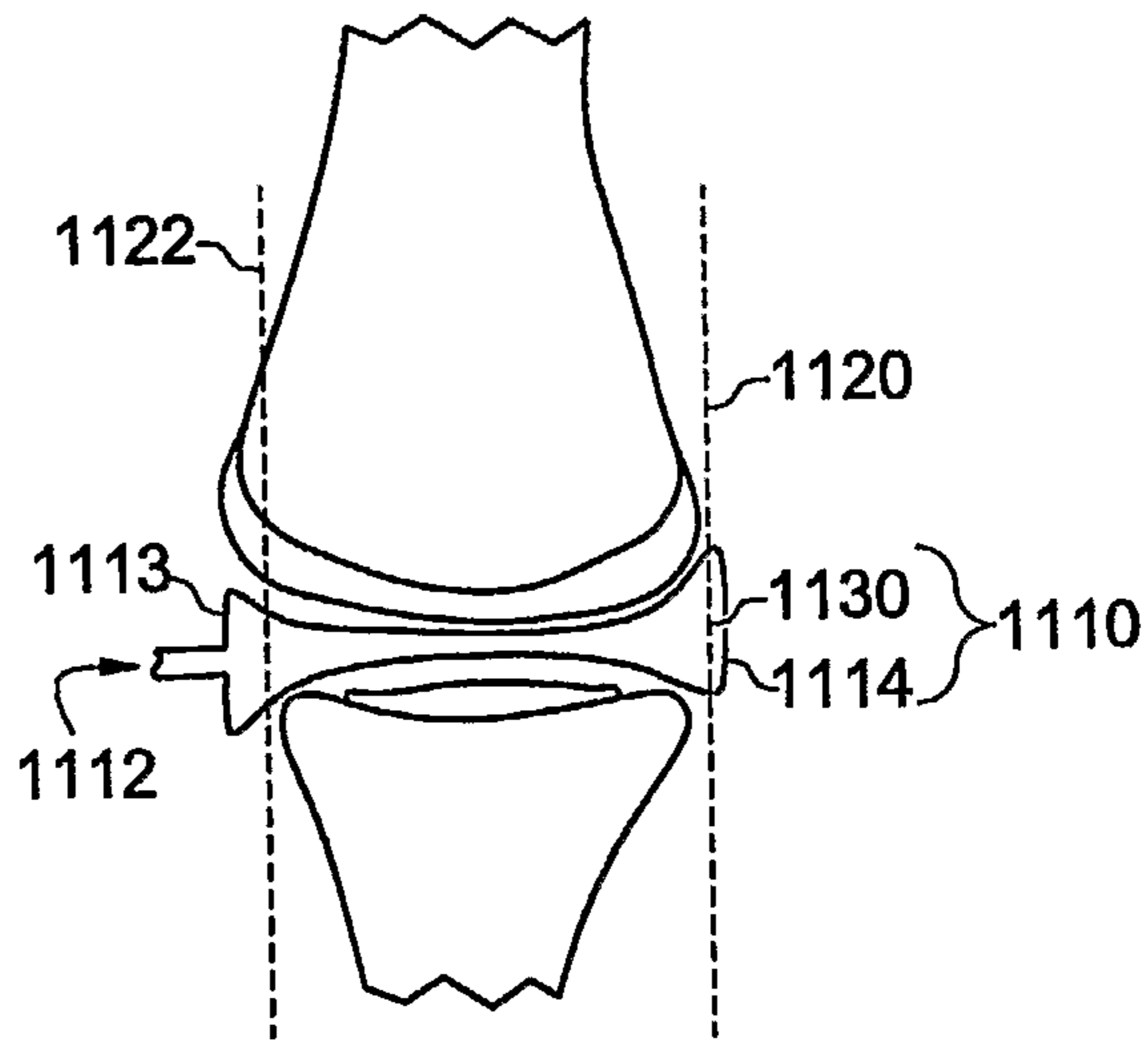

FIG. 11B

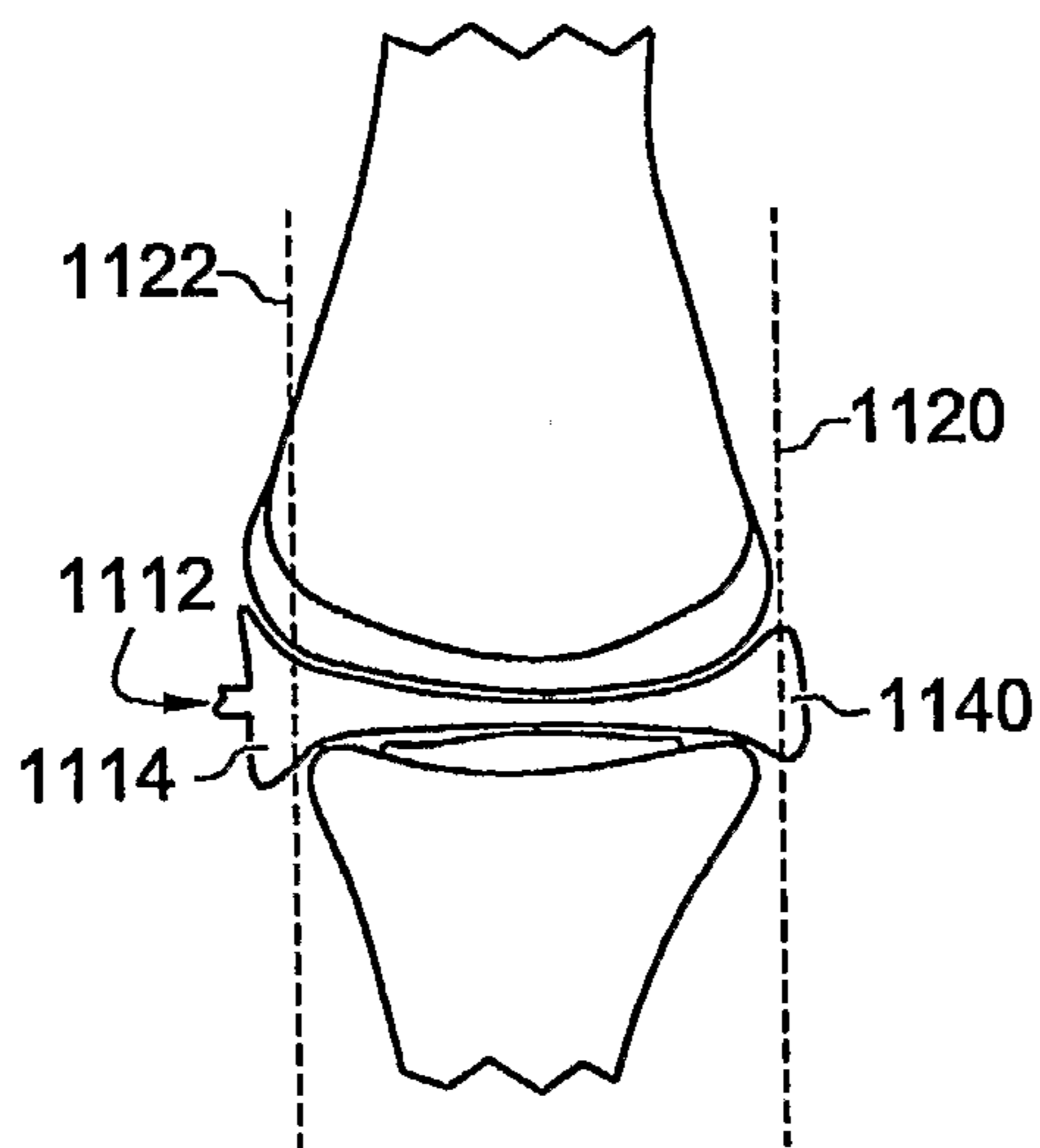

FIG. 11C

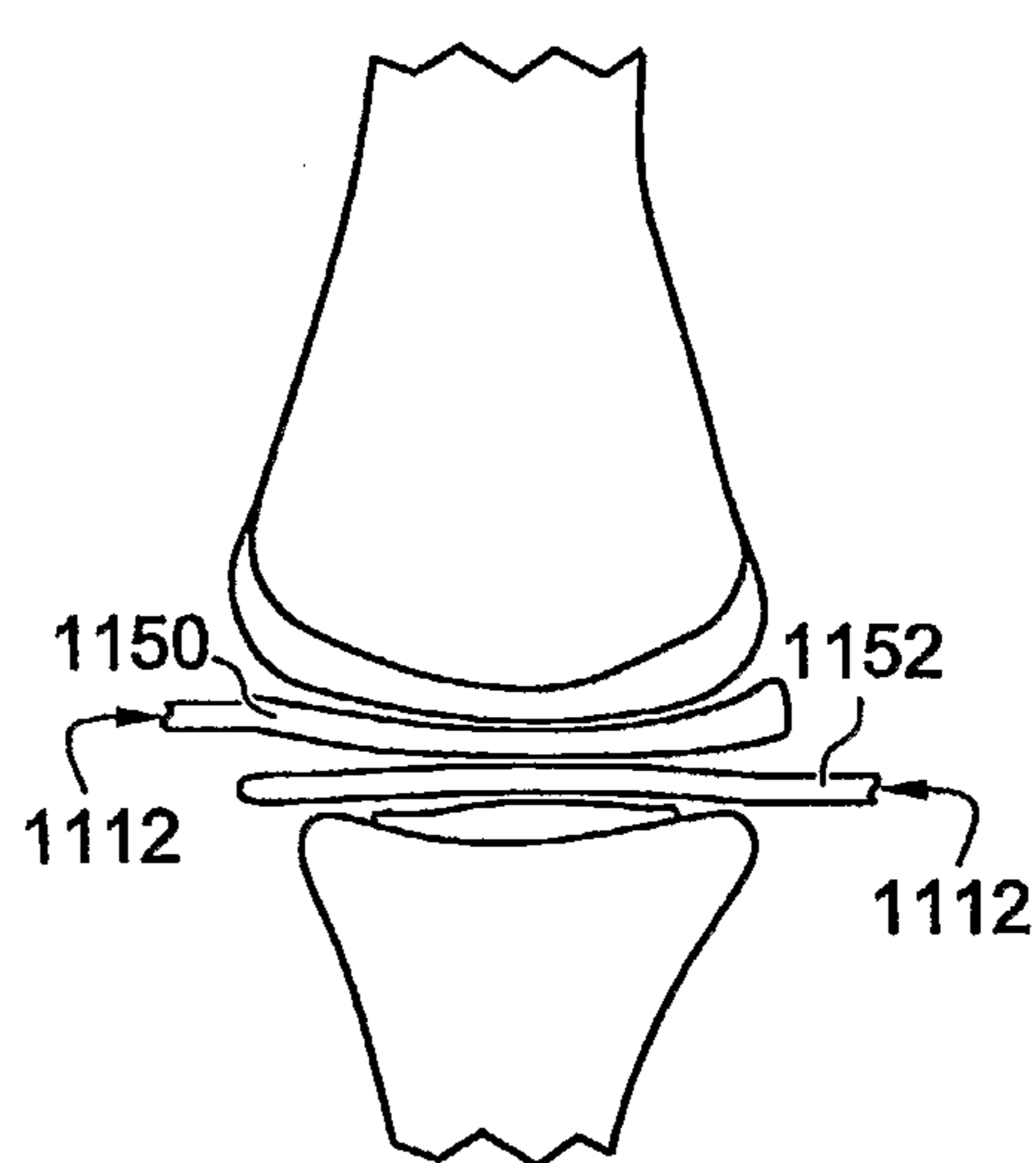

FIG. 11D

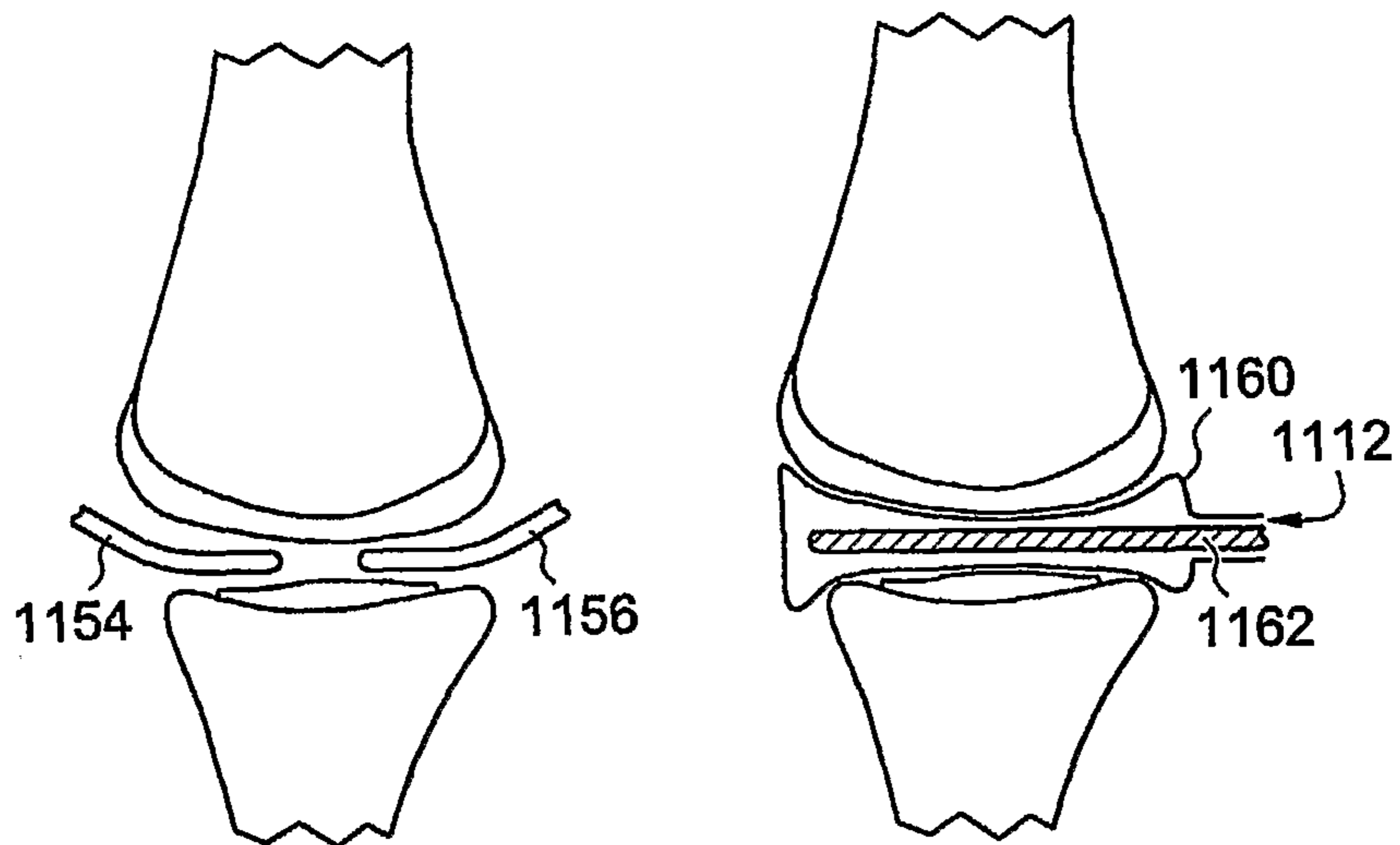

FIG. 11E

FIG. 11F

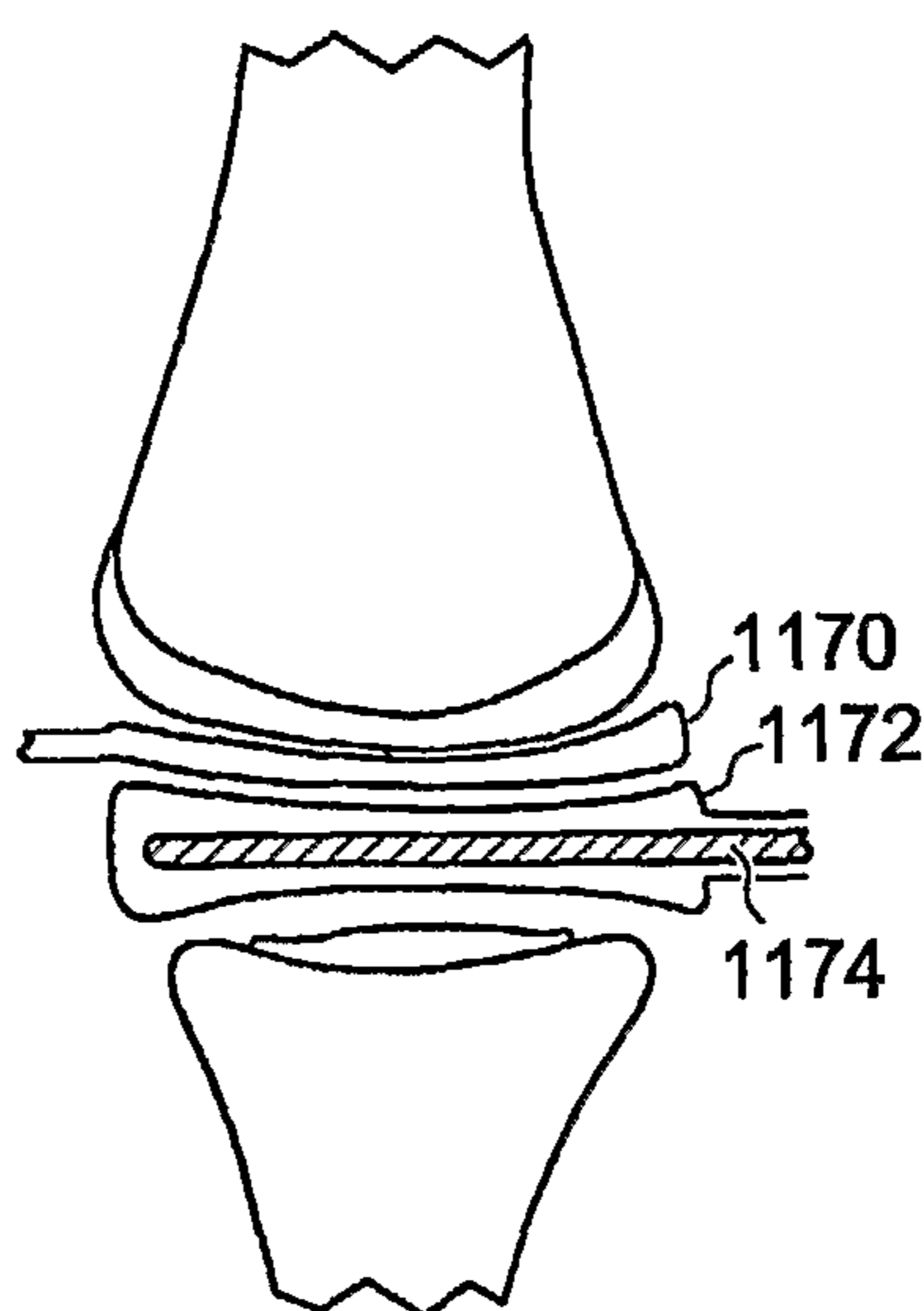

FIG. 11G

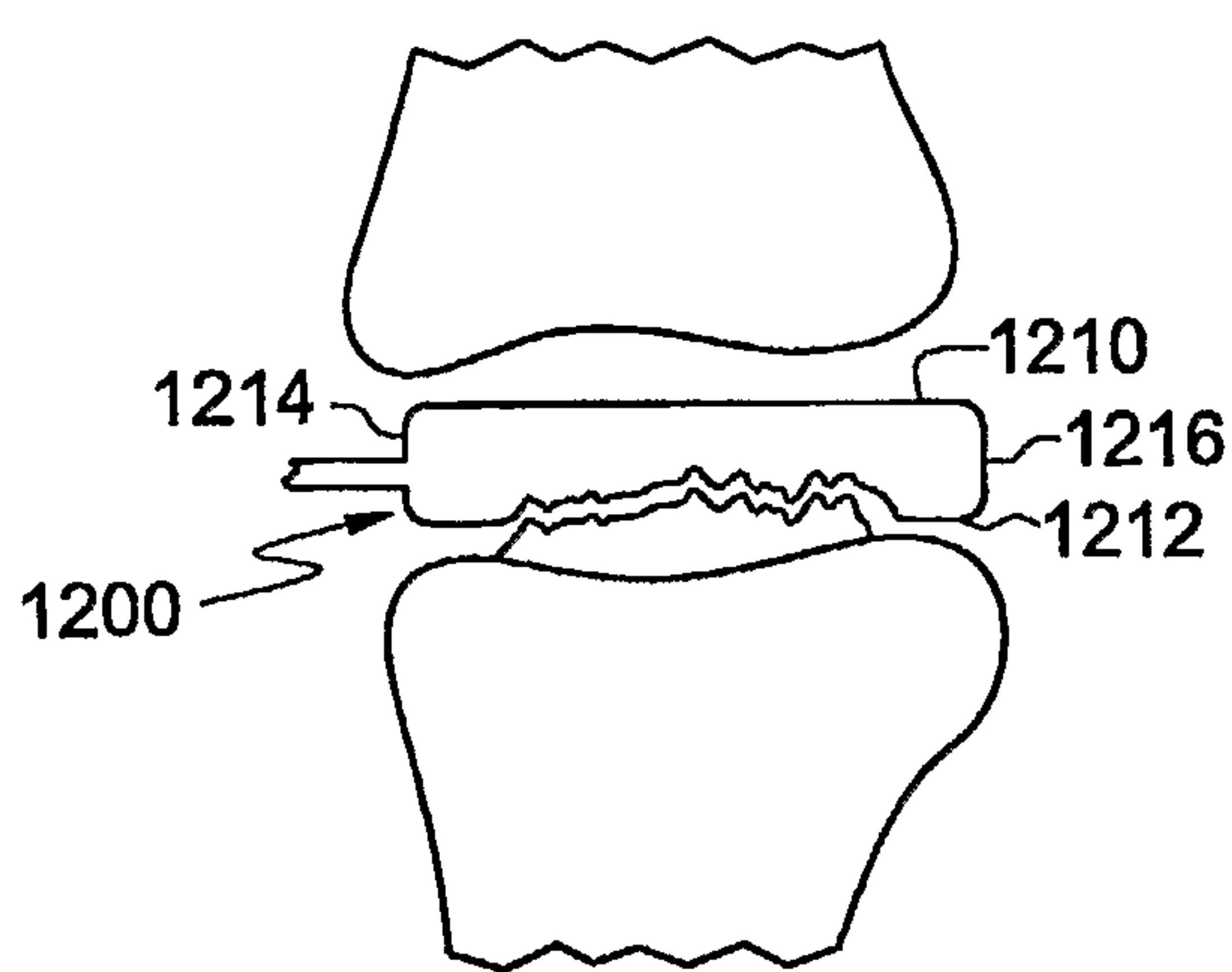

FIG. 12A

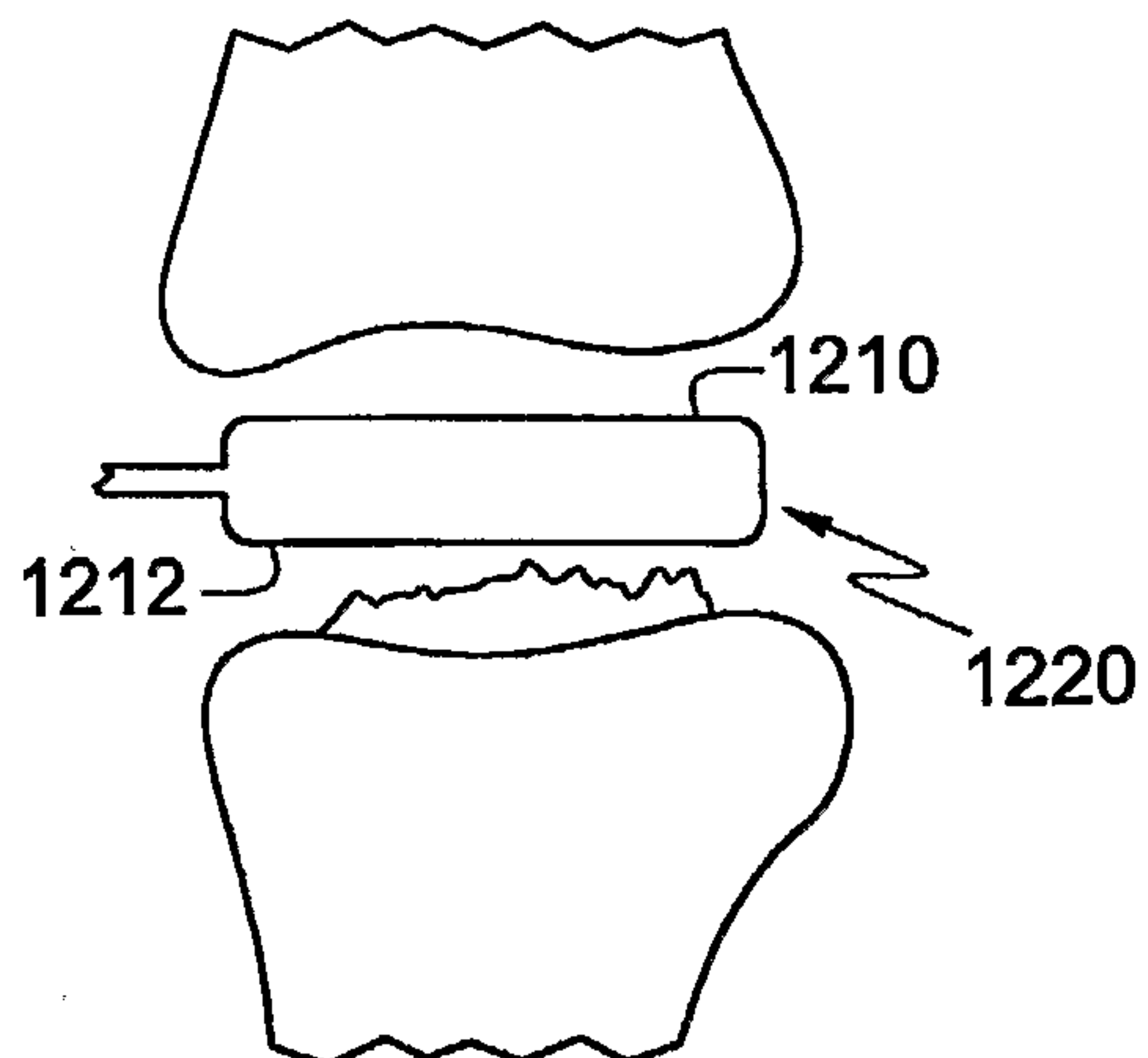

FIG. 12B

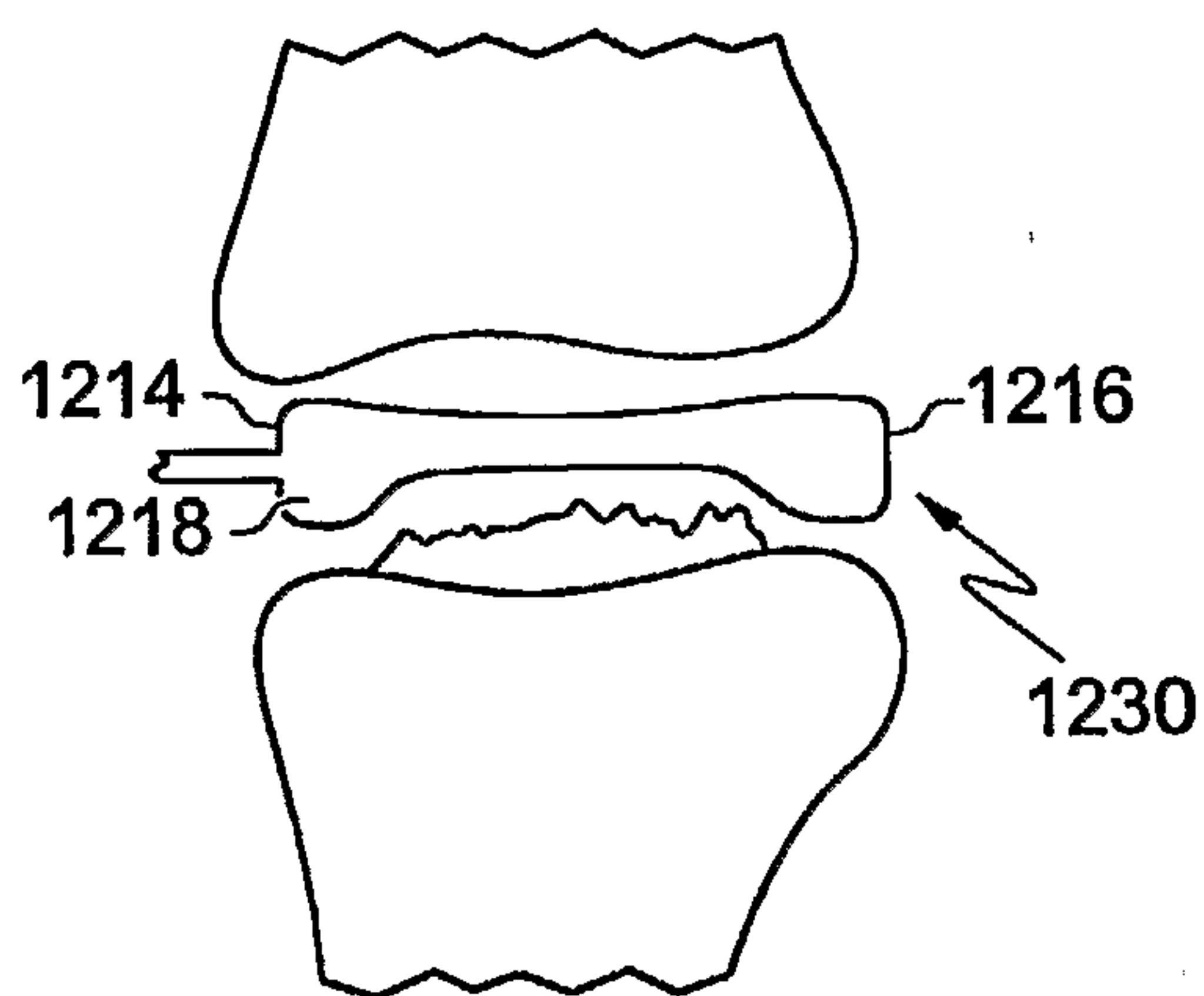

FIG. 12C

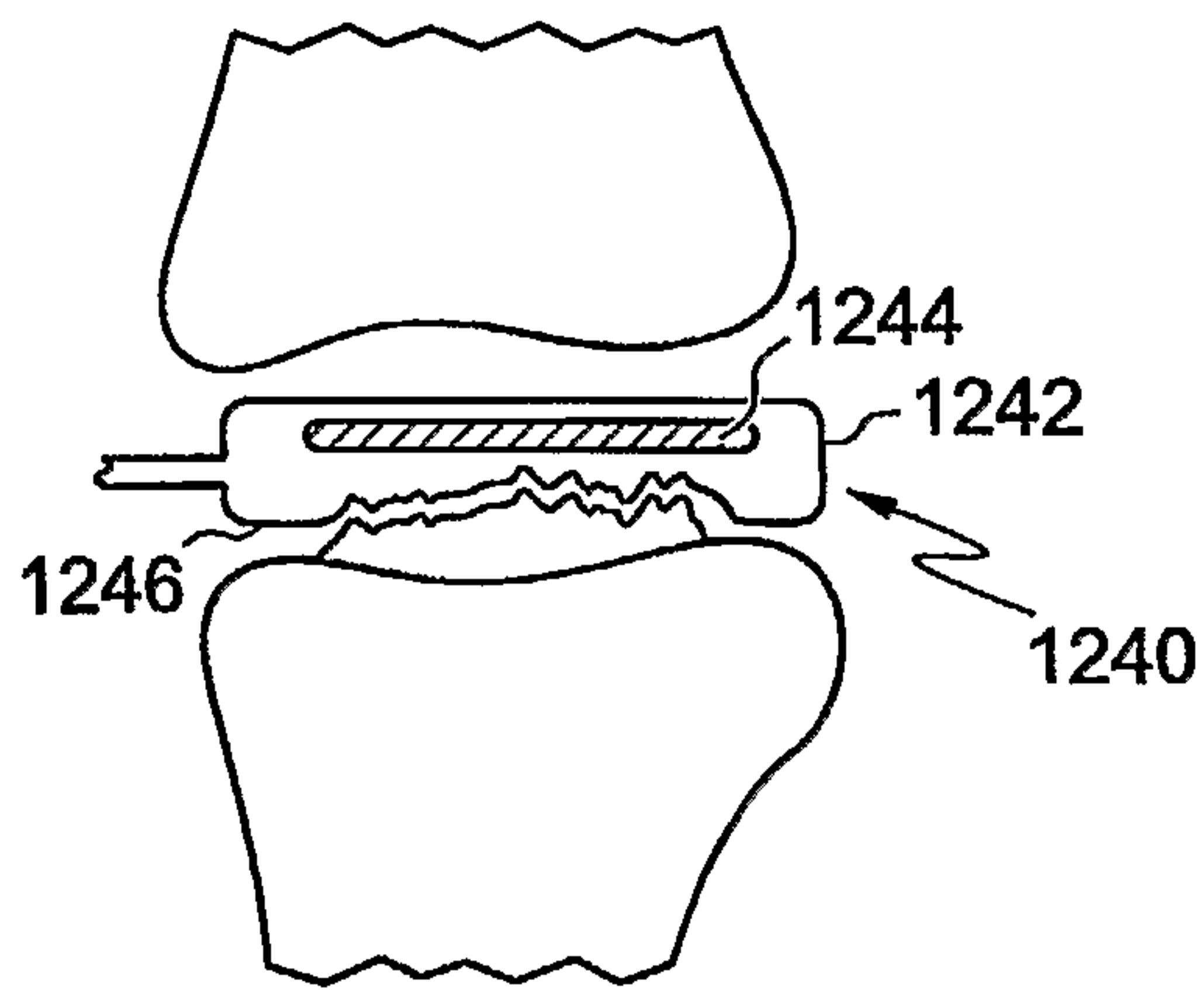

FIG. 12D

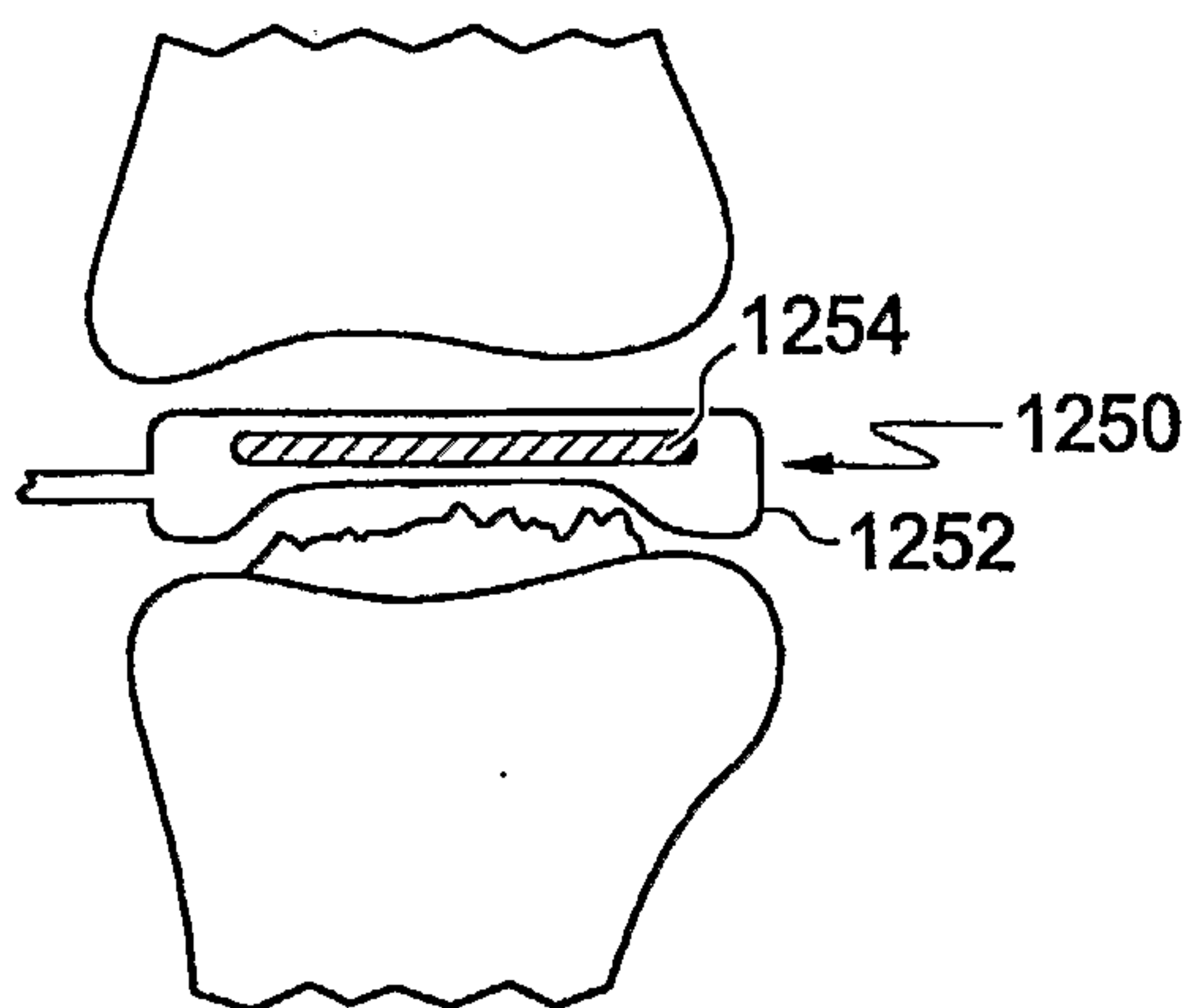

FIG. 12E

14 / 36

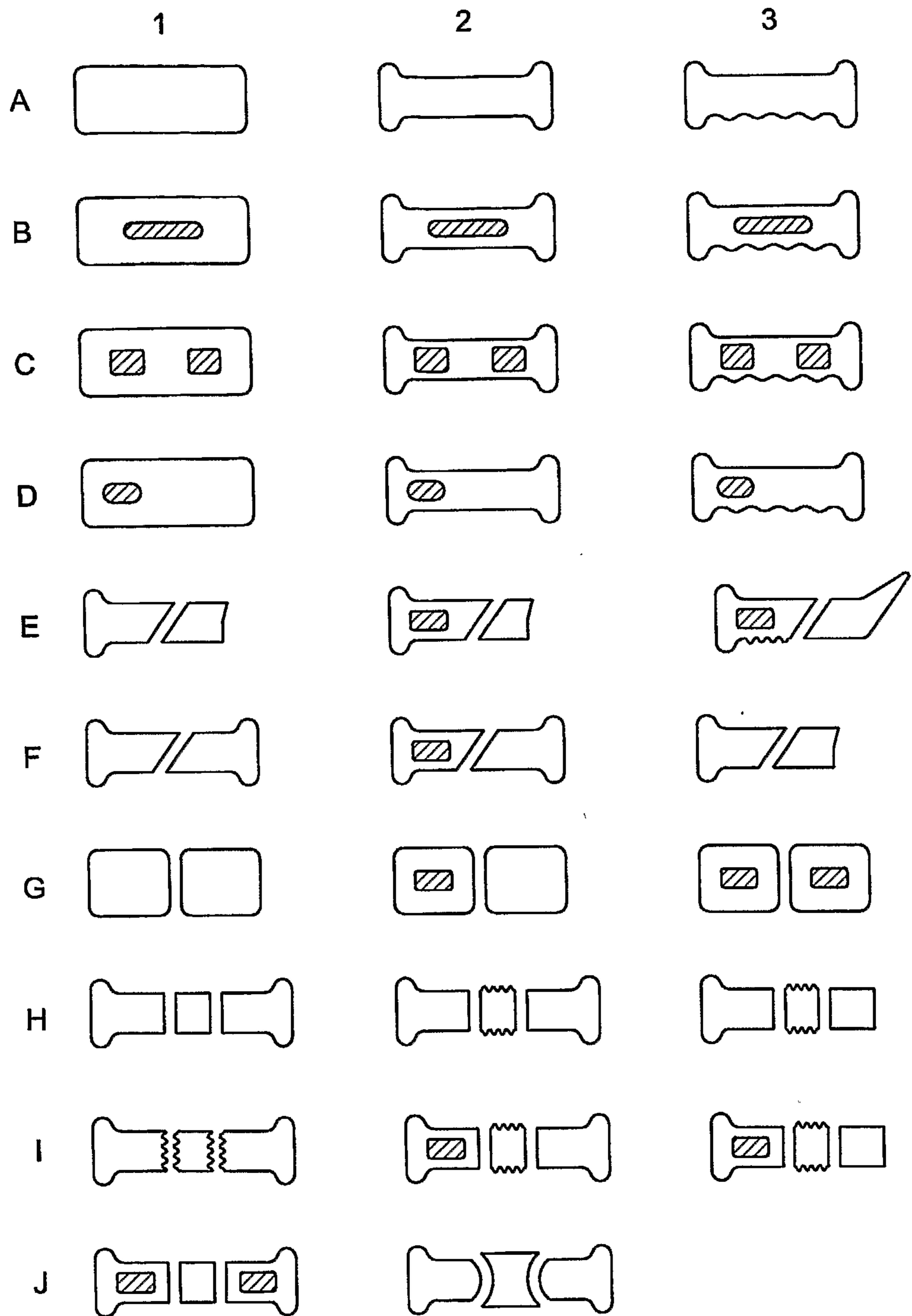

FIG. 13

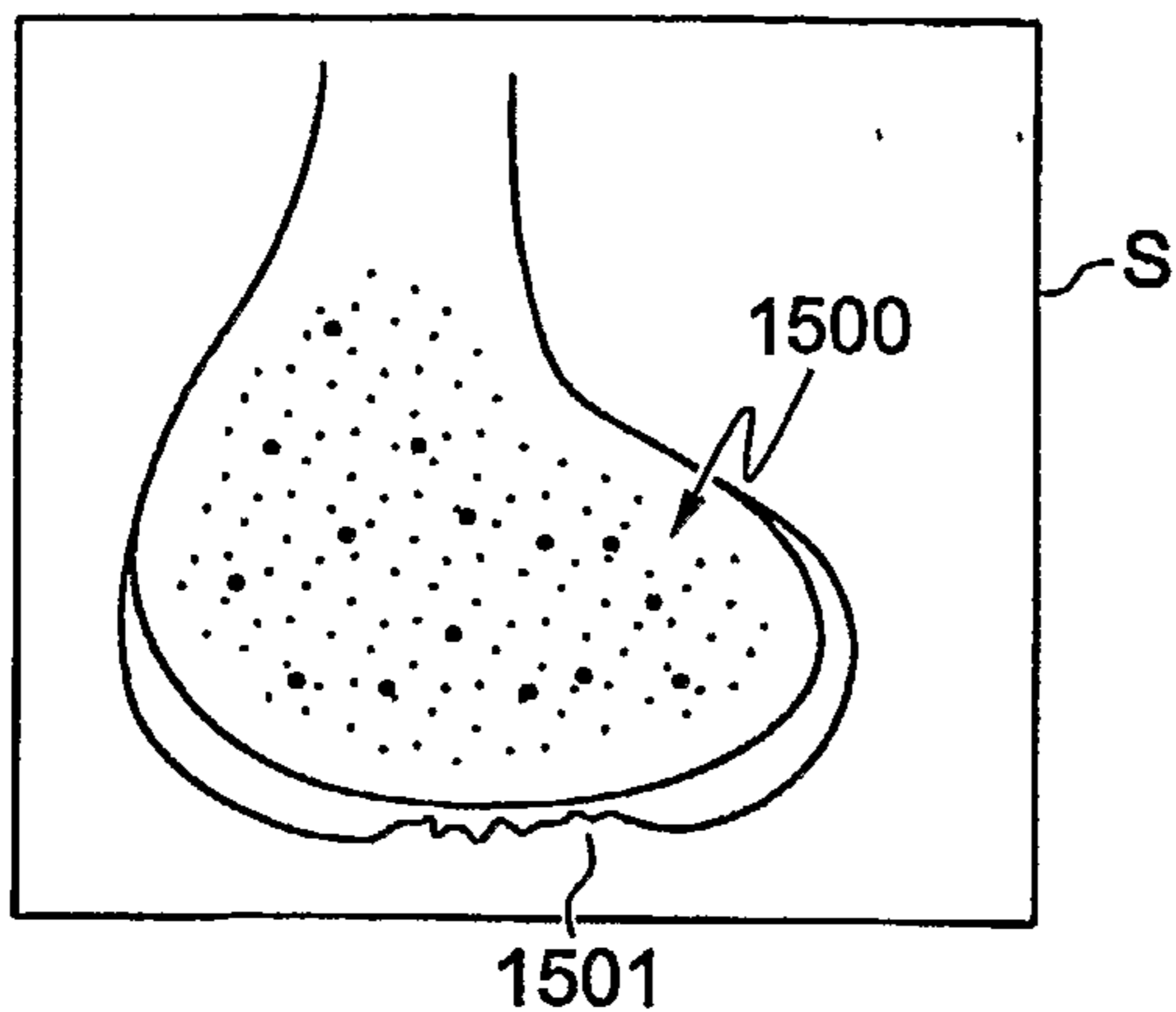

FIG. 14A

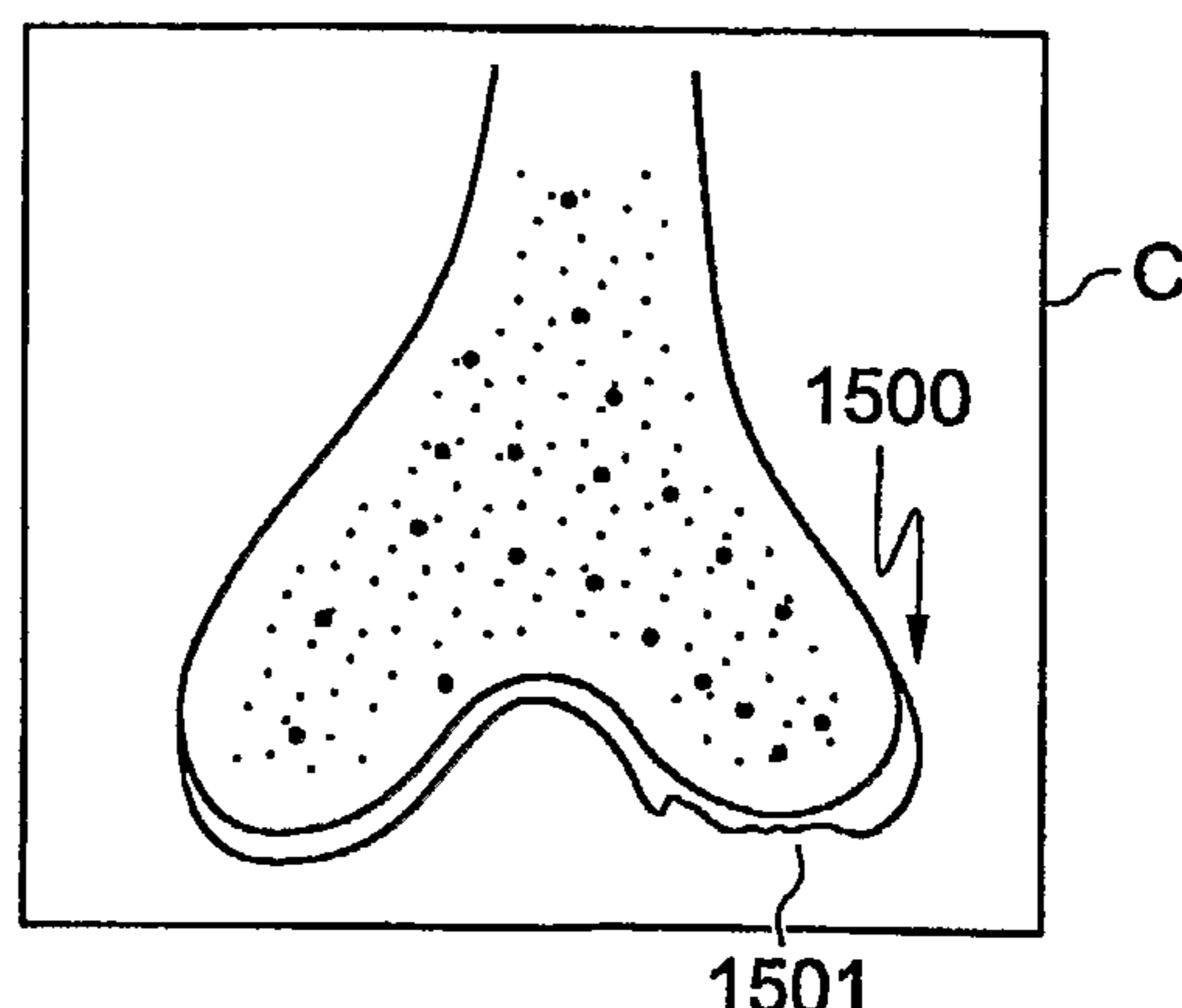

FIG. 14D

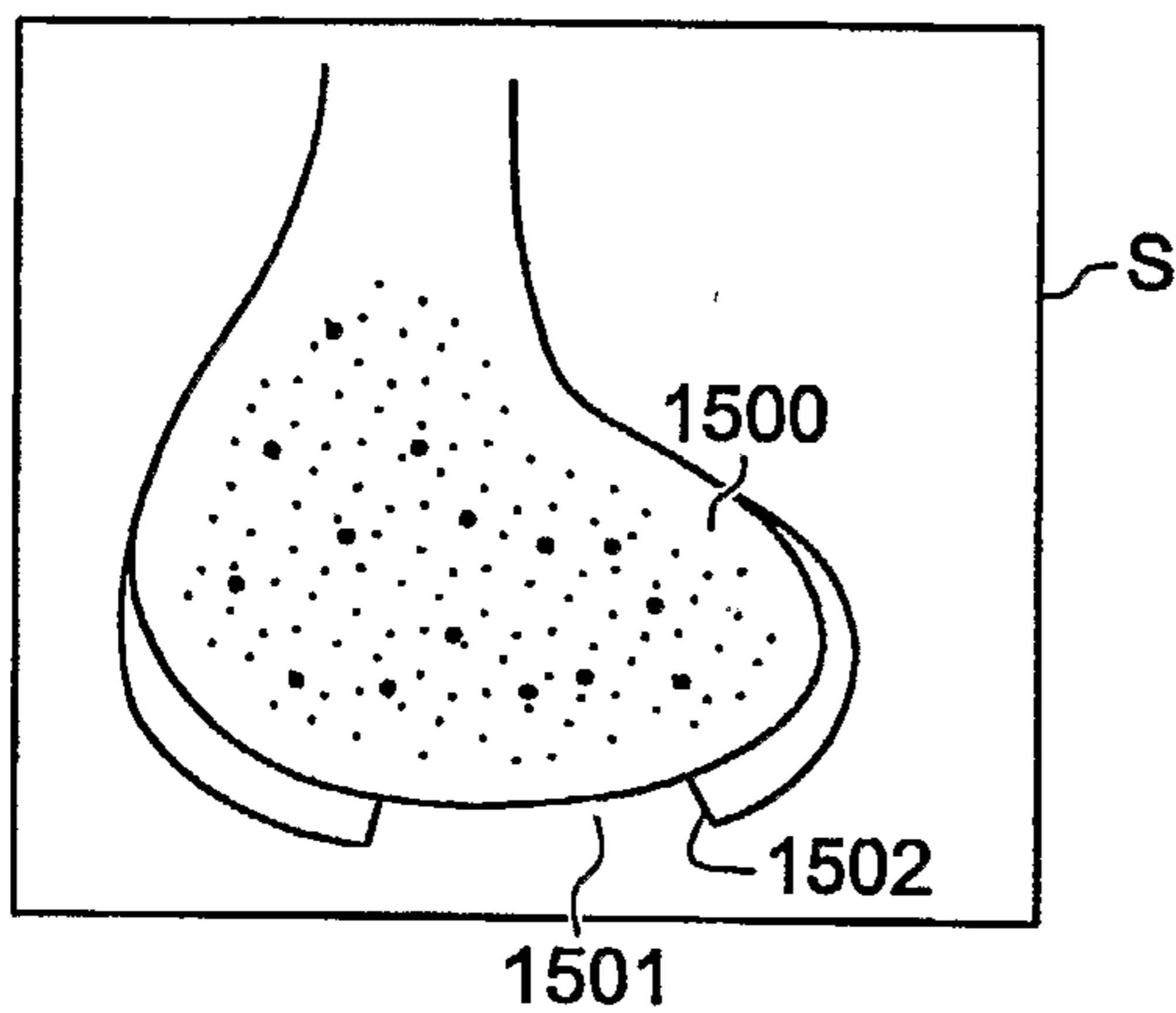

FIG. 14B

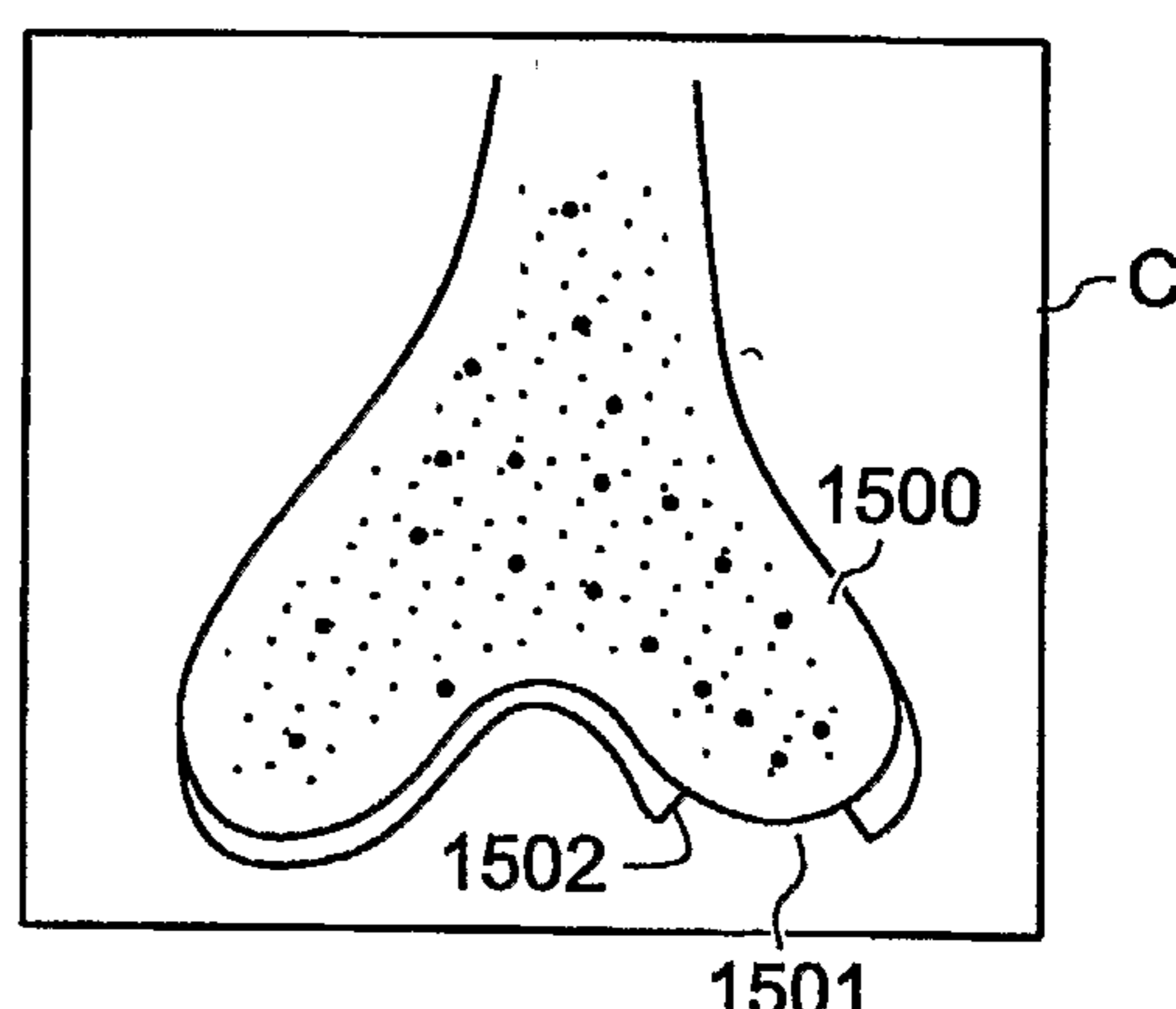

FIG. 14E

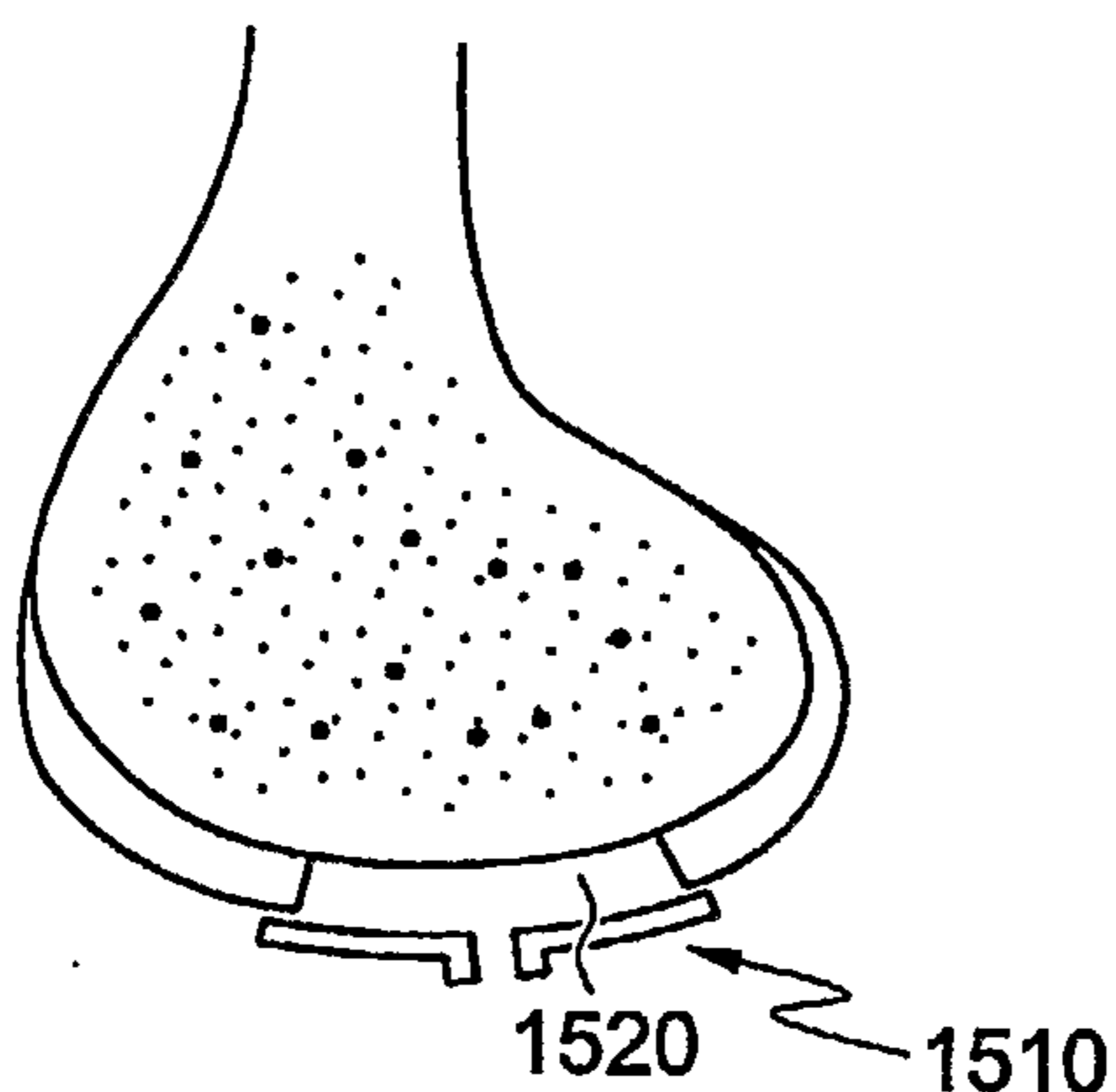

FIG. 14C

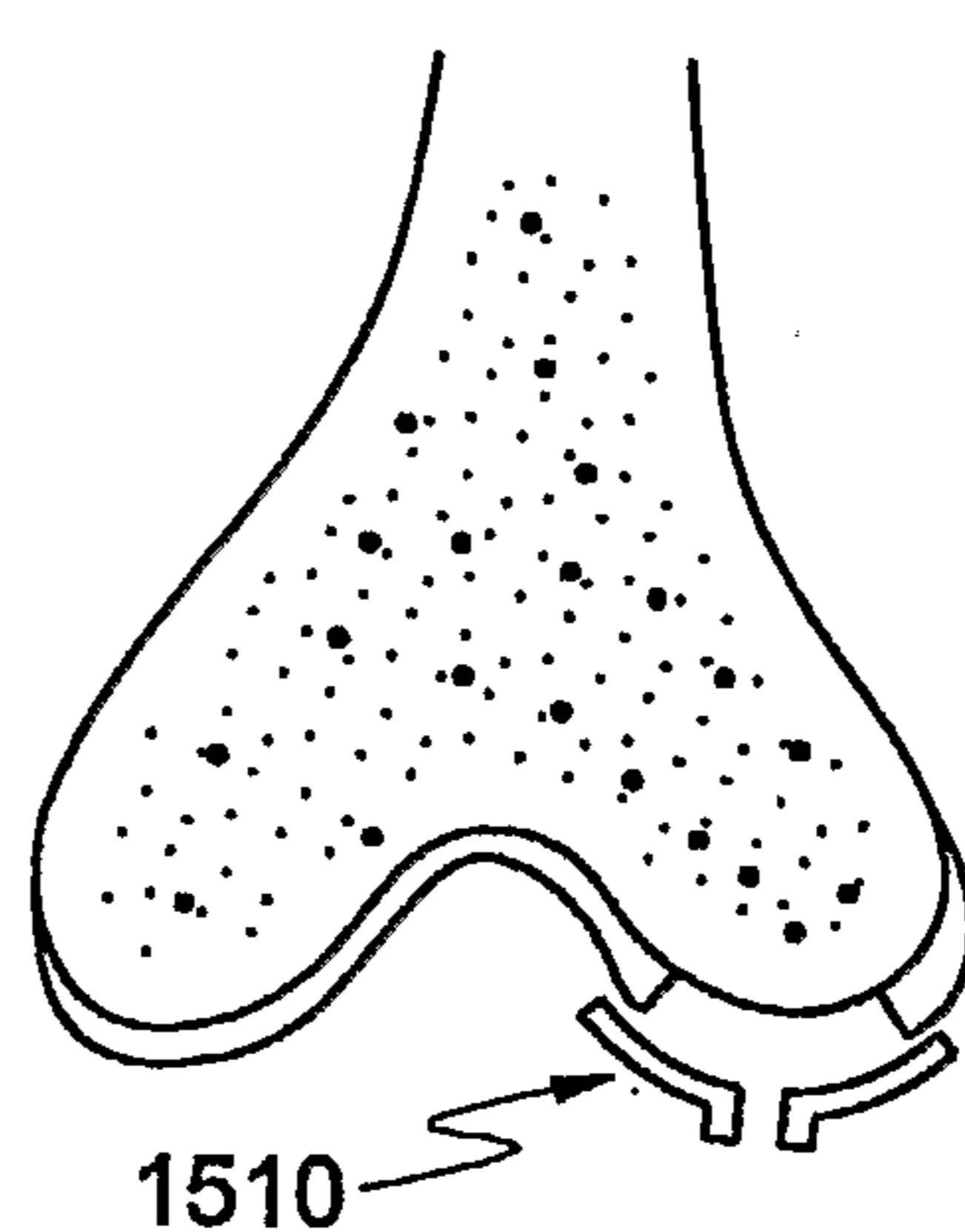

FIG. 14F

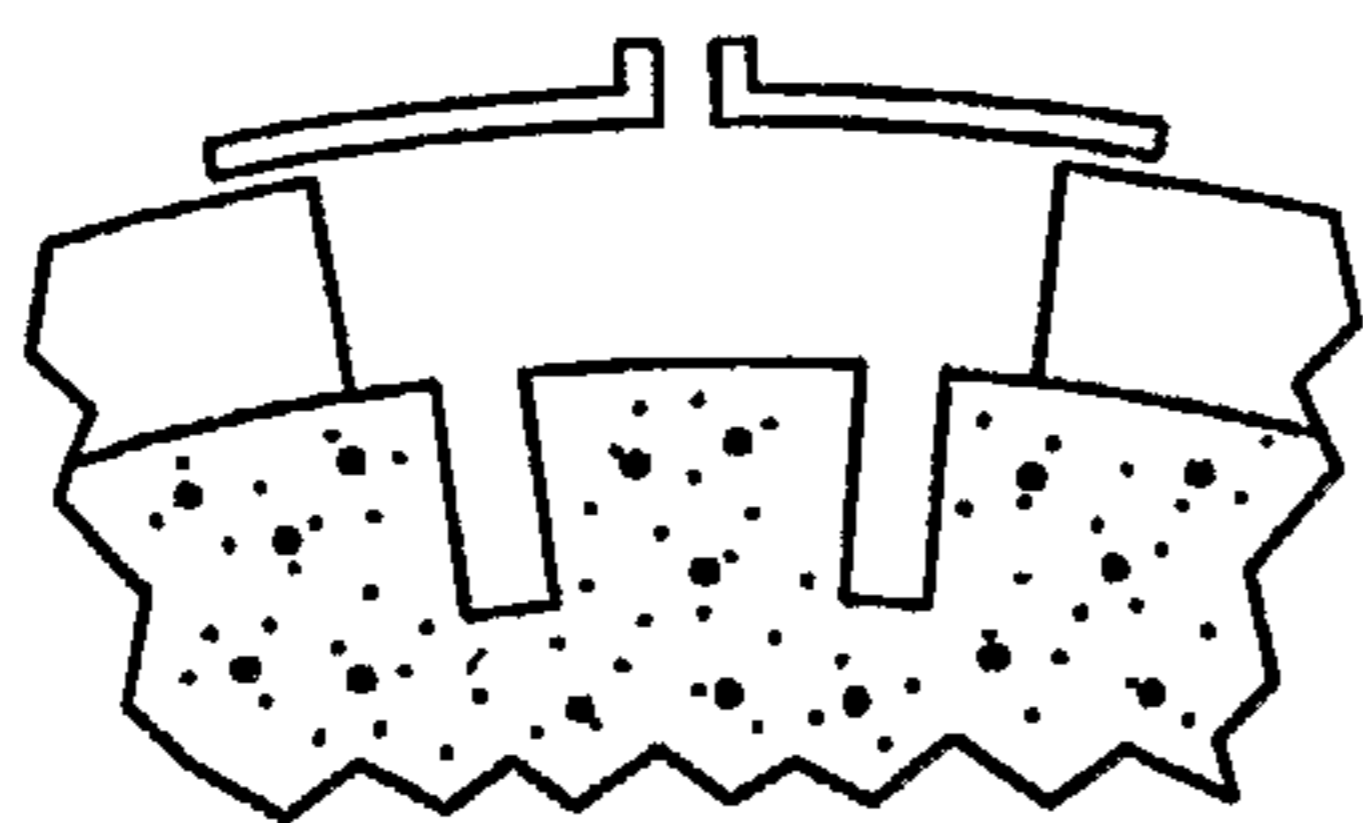

FIG. 14G(1)

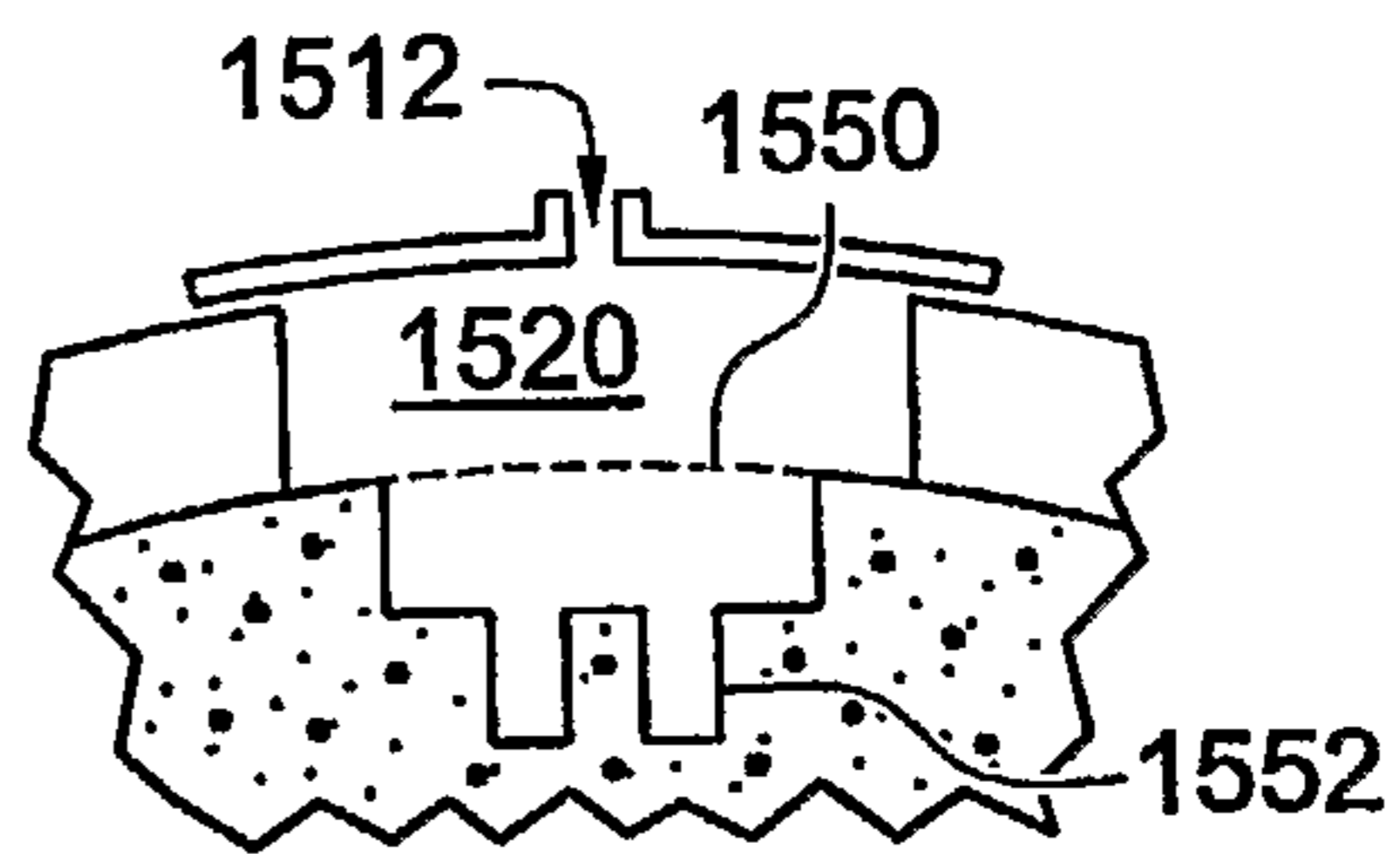

FIG. 14G(2)

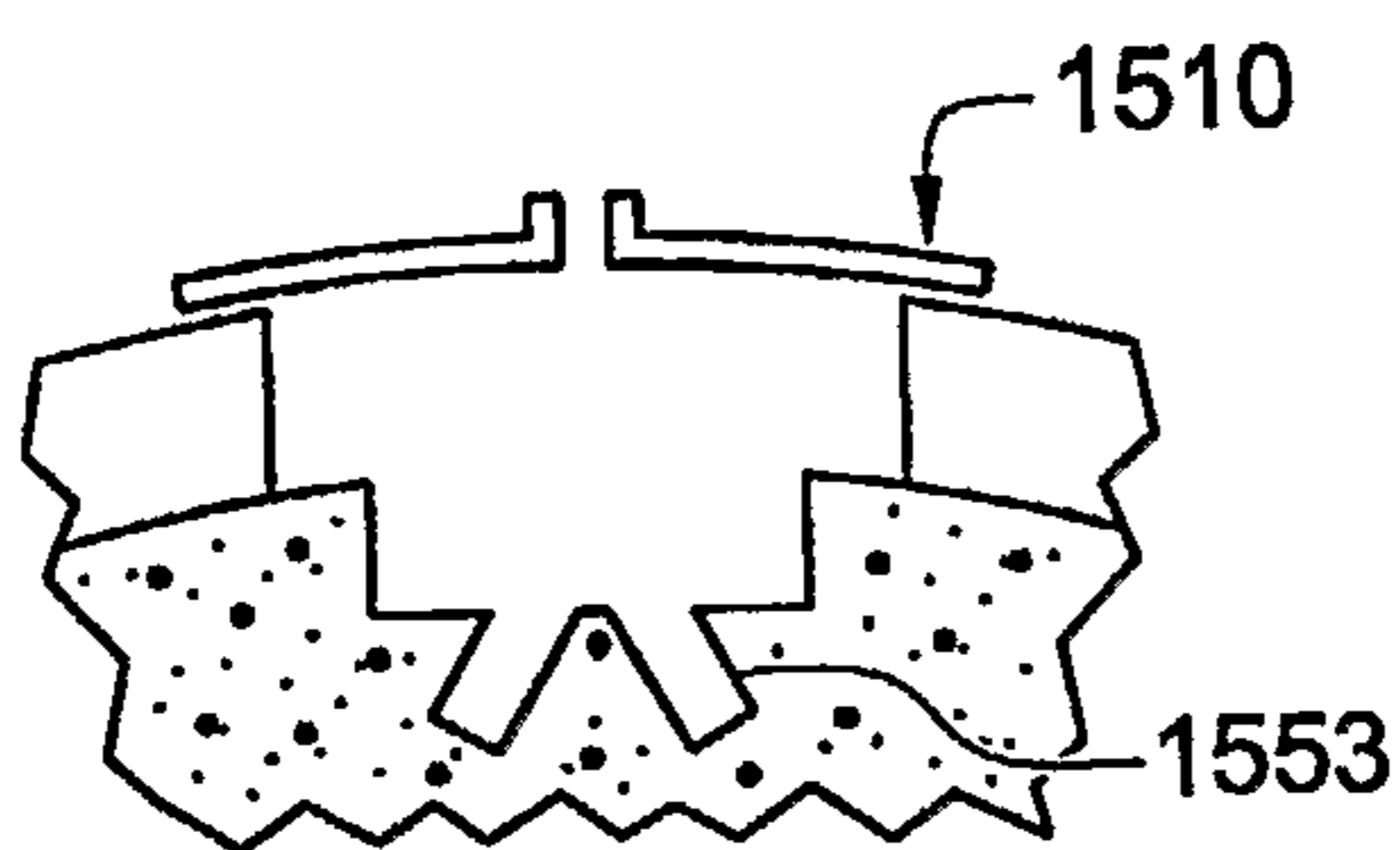

FIG. 14G(3)

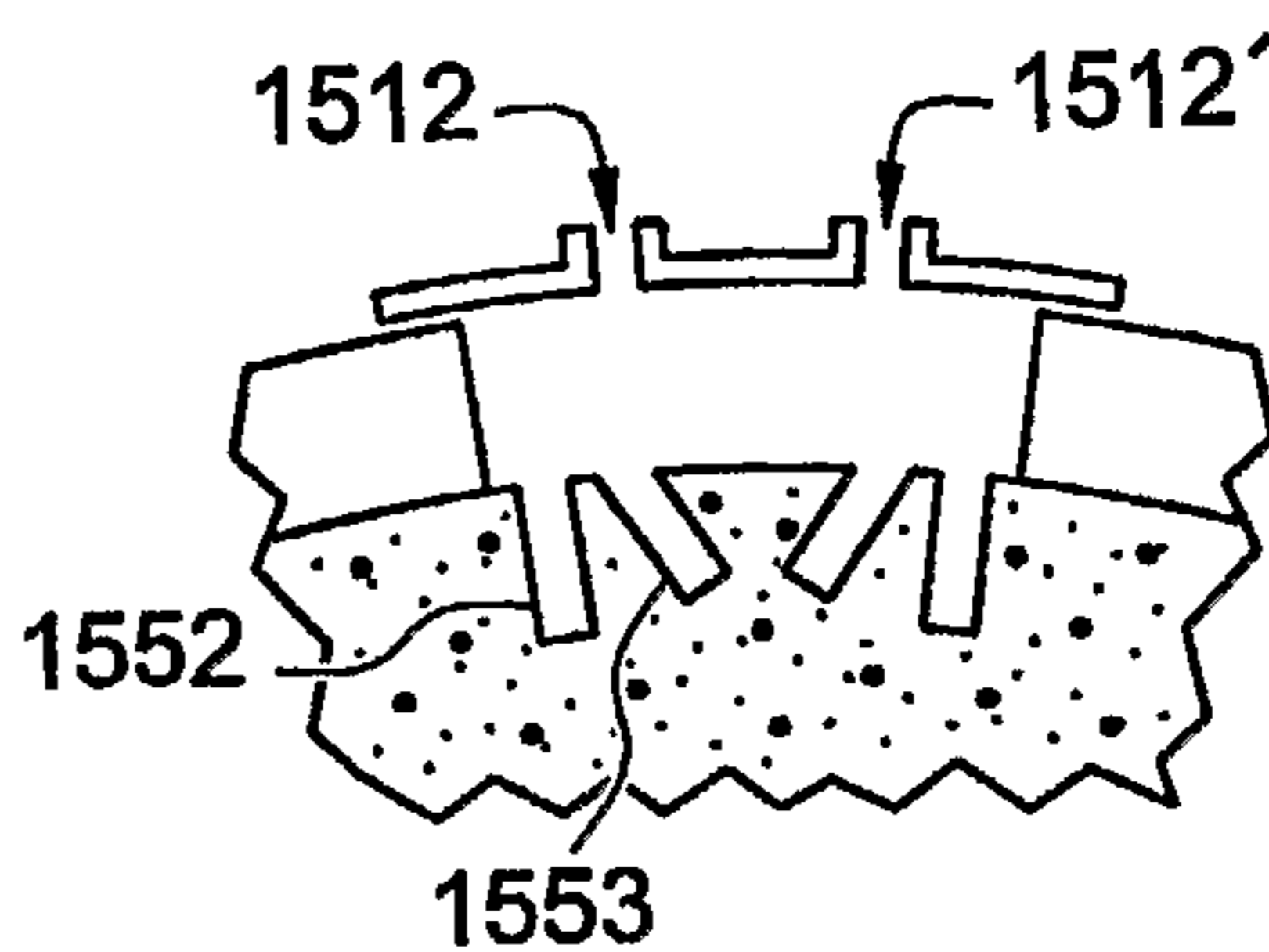

FIG. 14G(4)

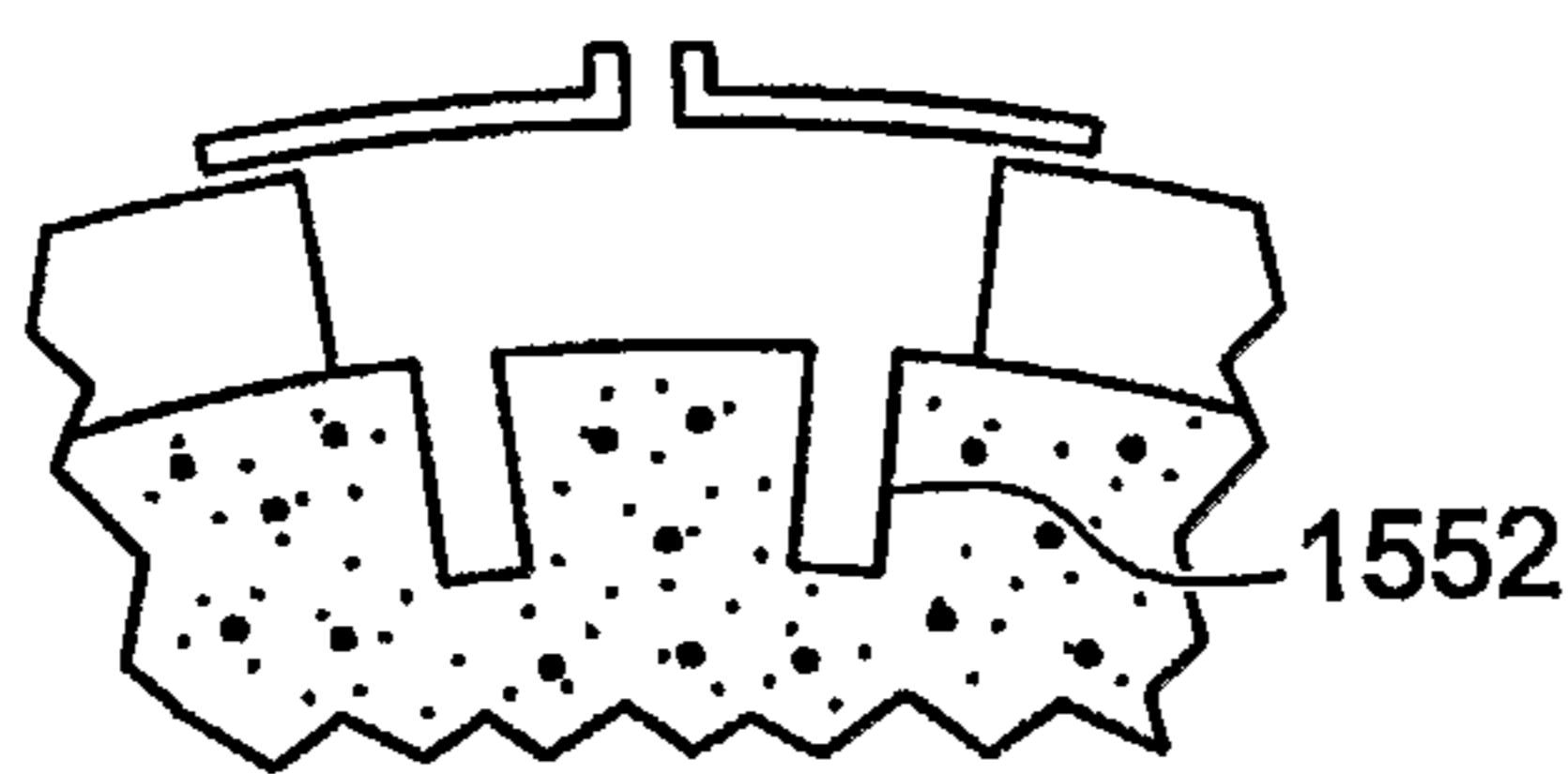

FIG. 14G(5)

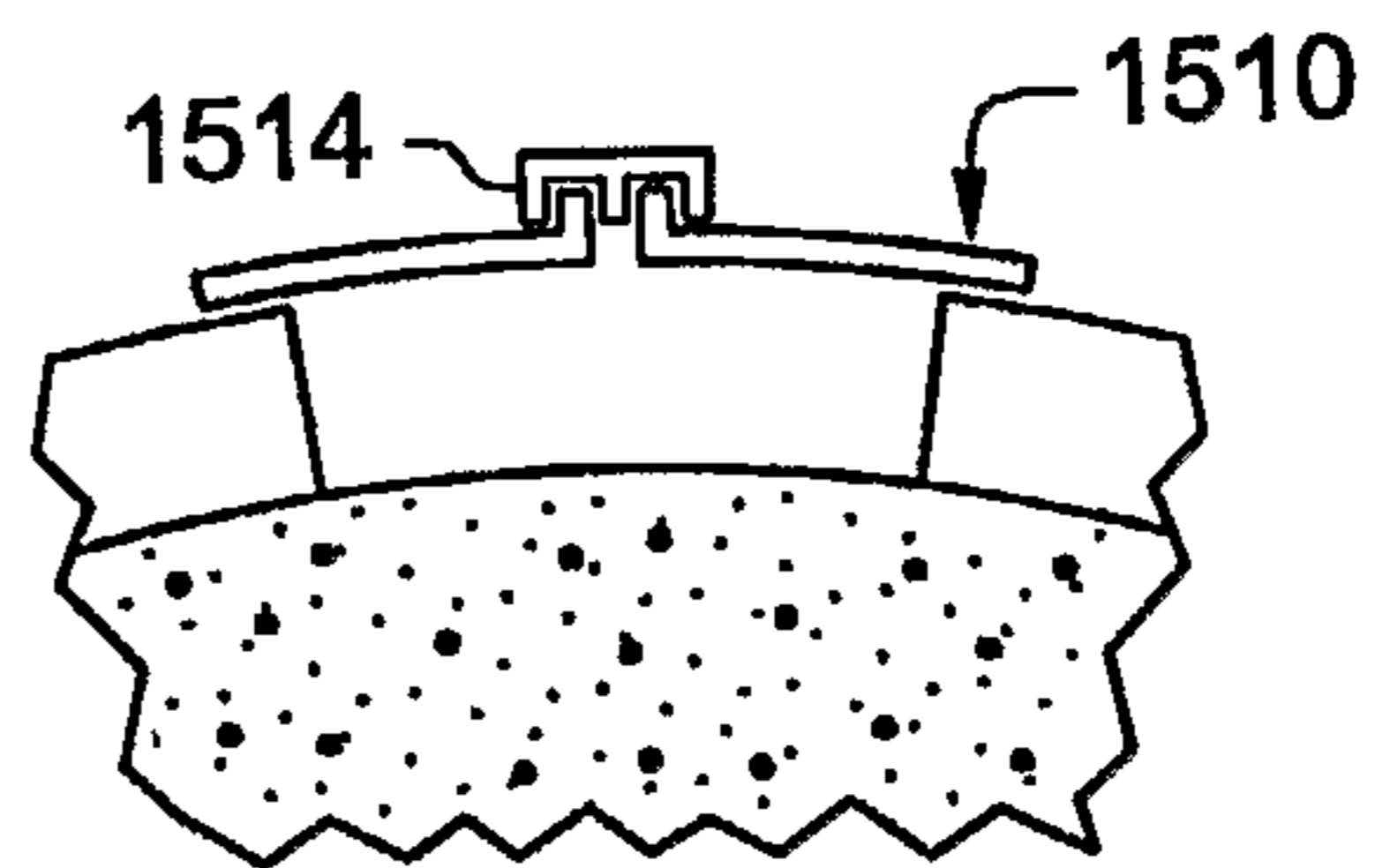

FIG. 14G(6)

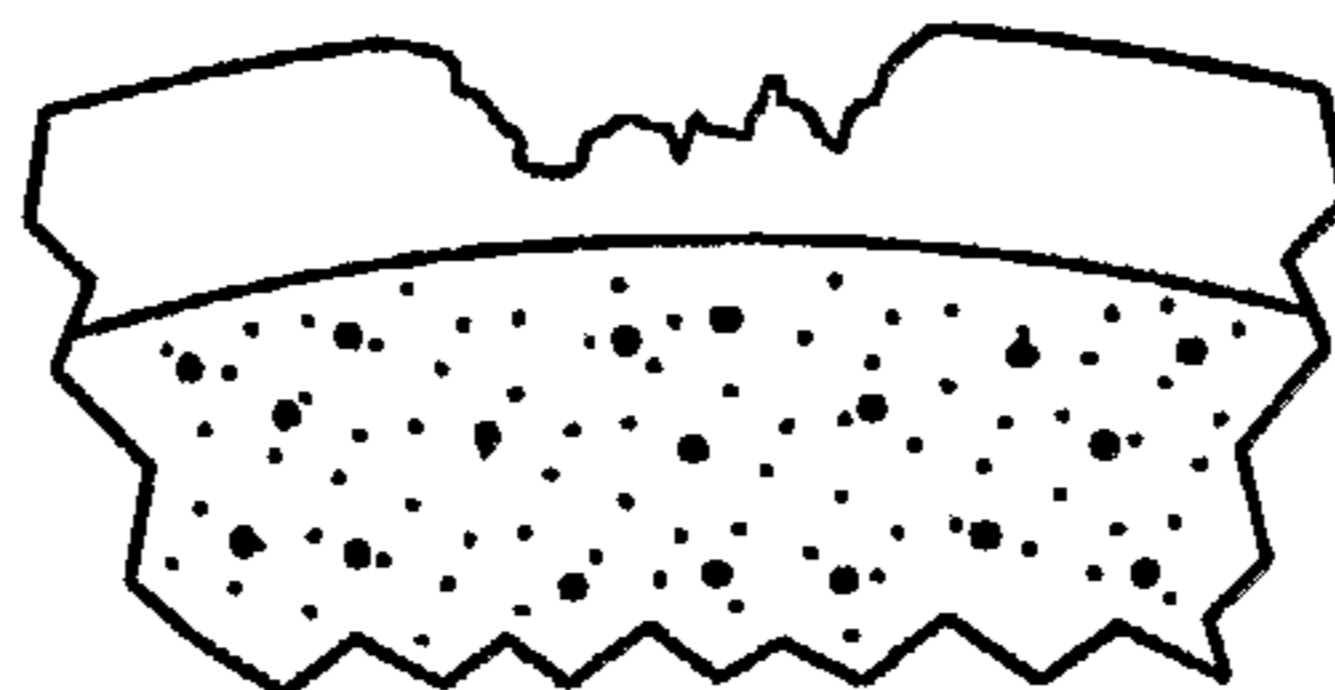

FIG. 14G(7)

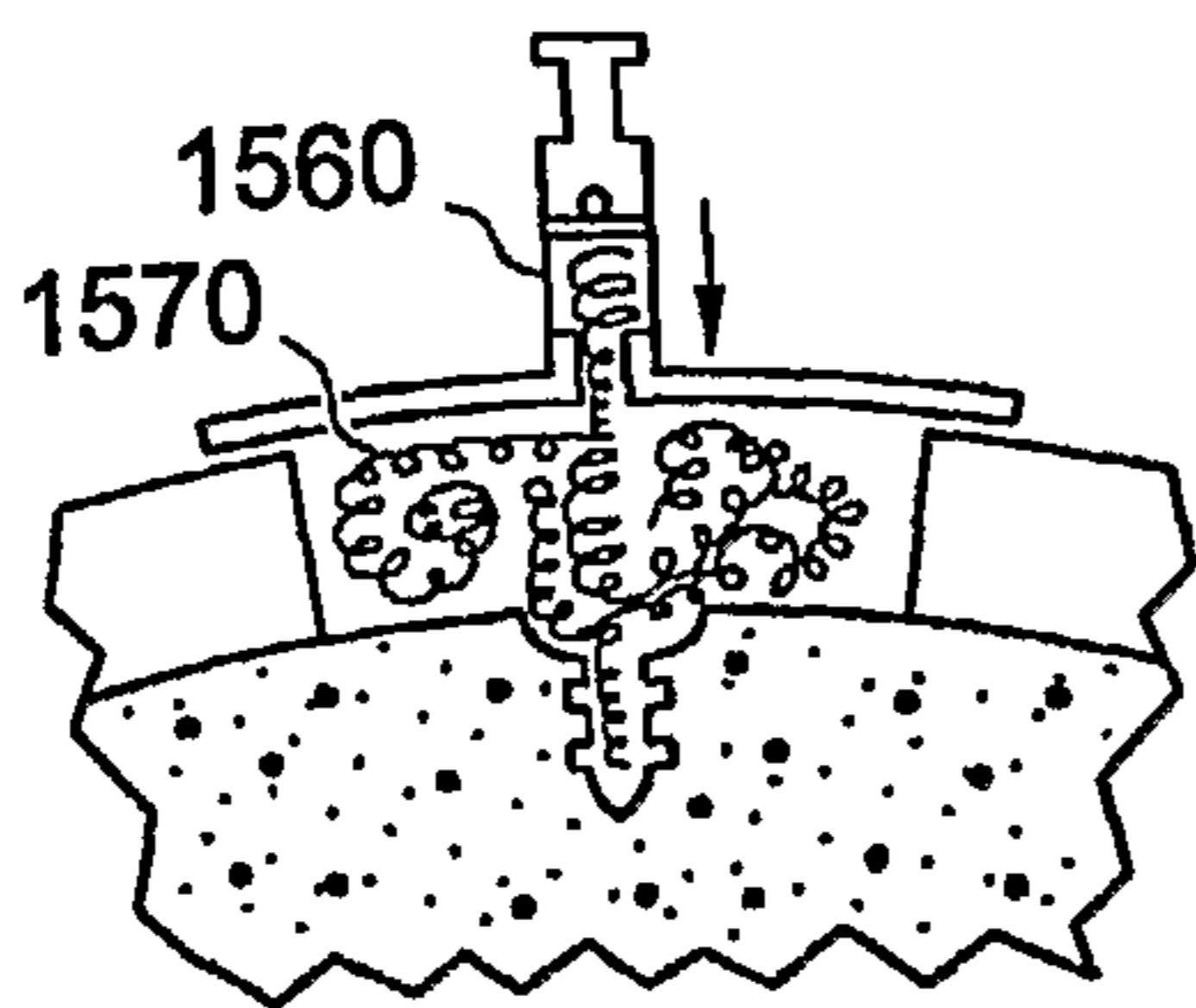

FIG. 14G(8)

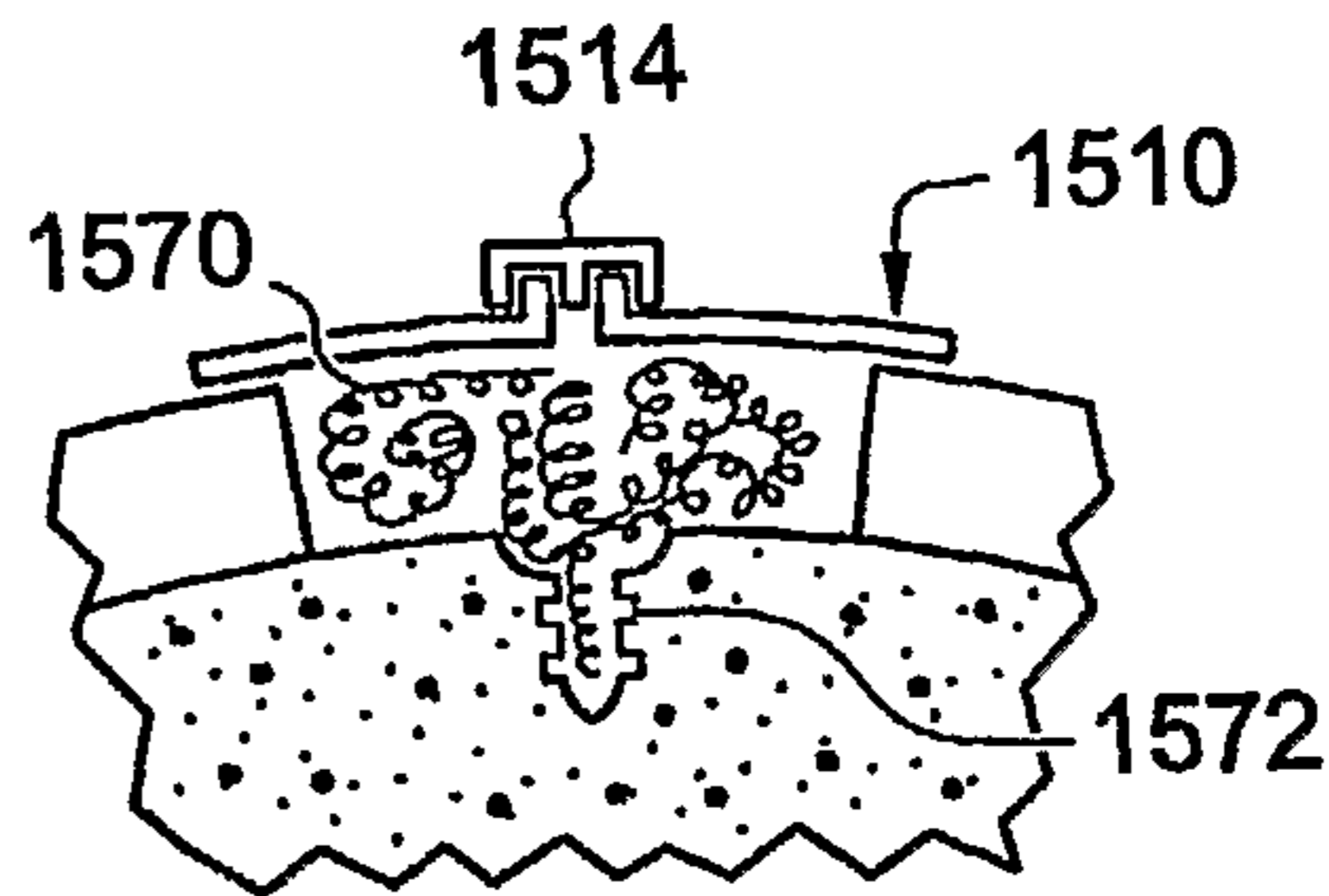

FIG. 14G(9)

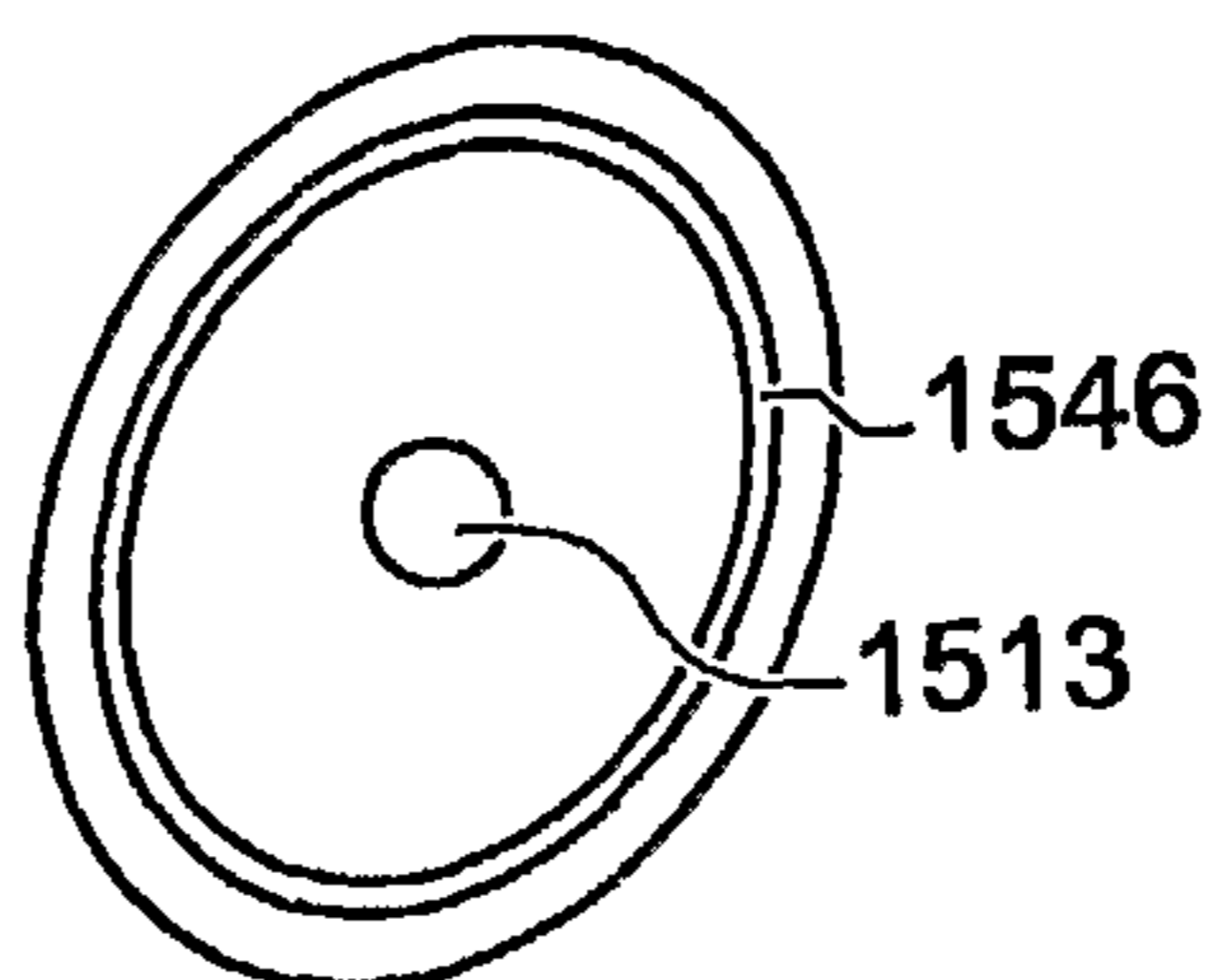

FIG. 14H

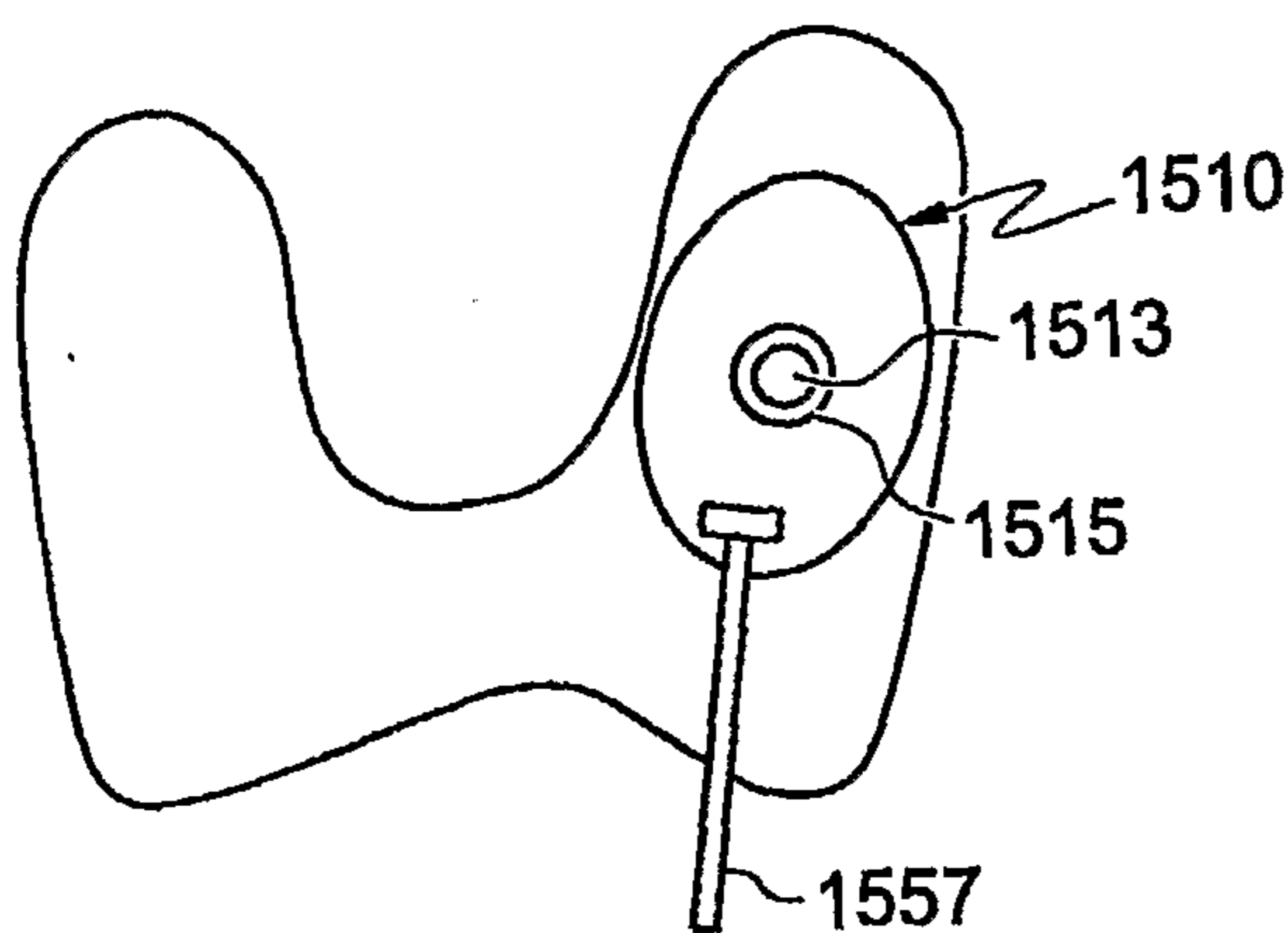

FIG. 14I

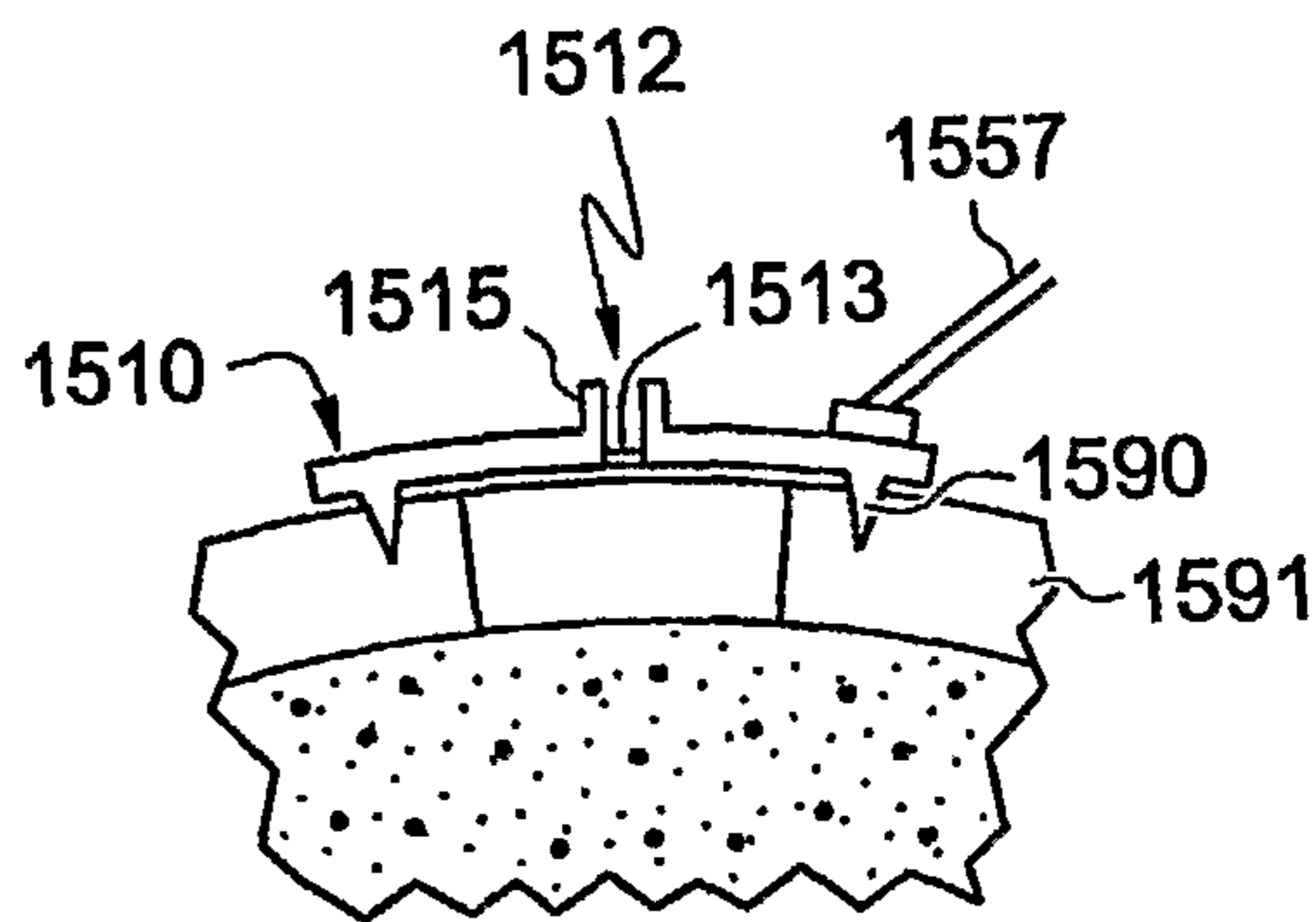

FIG. 14J

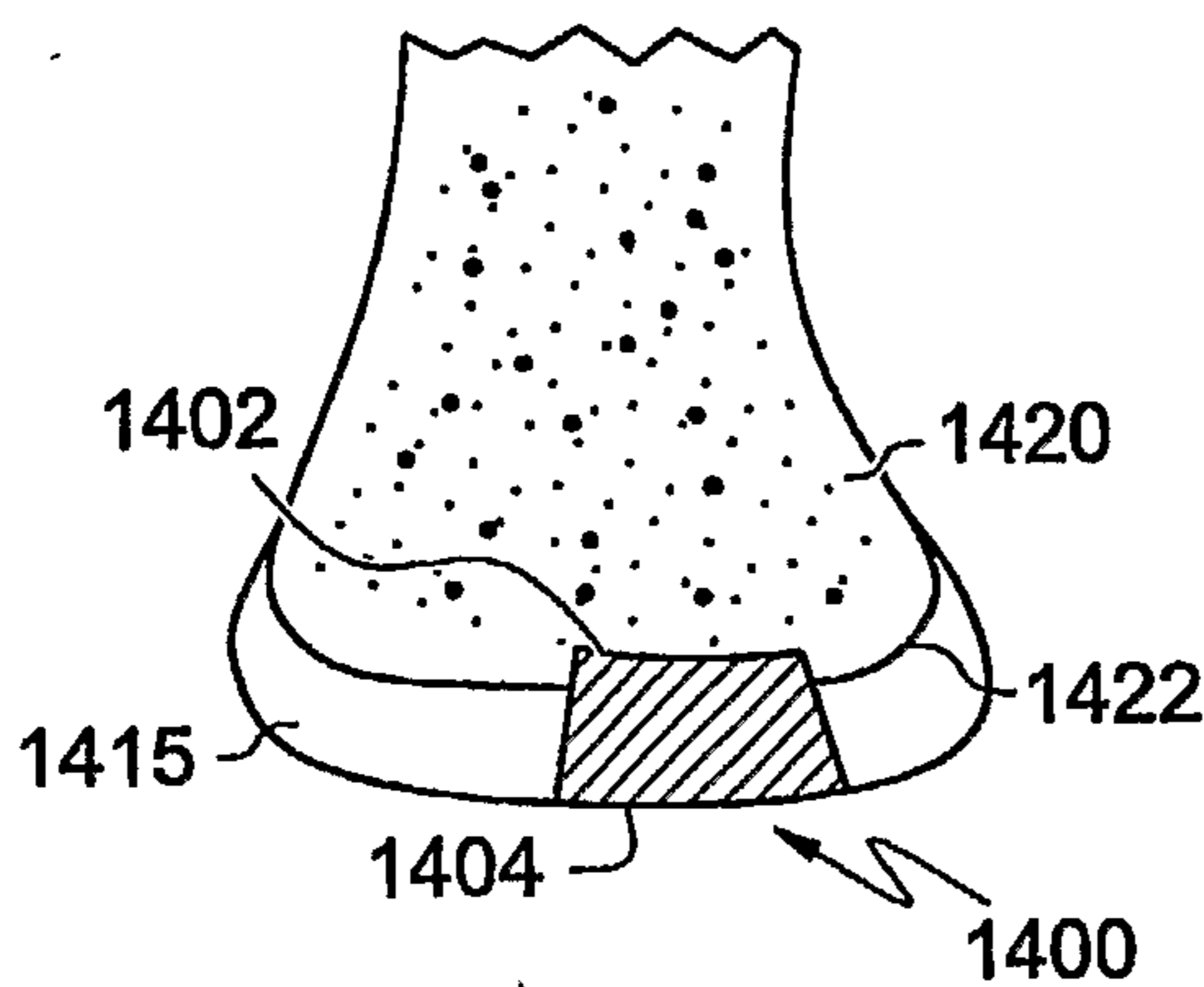

FIG. 15A

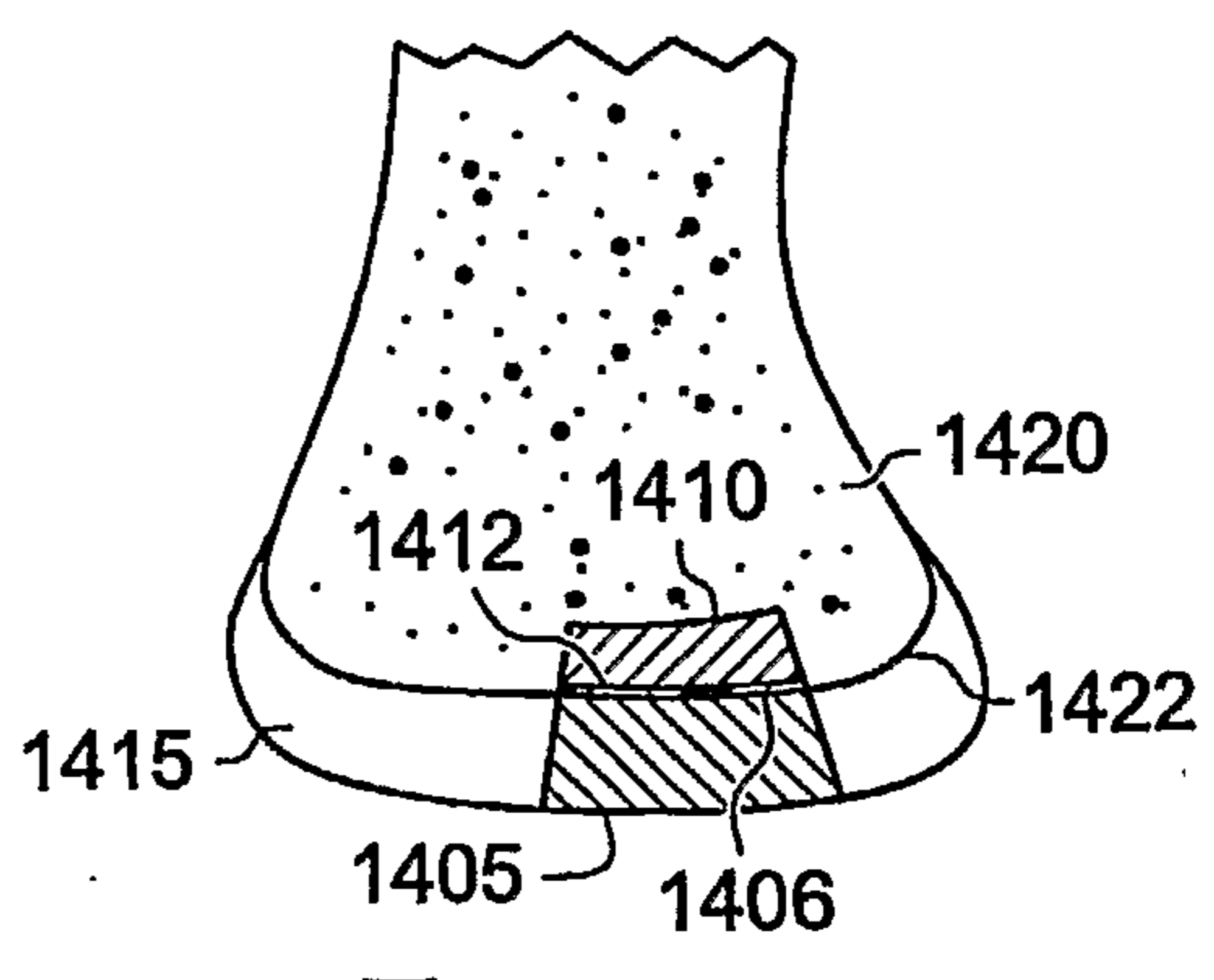

FIG. 15B

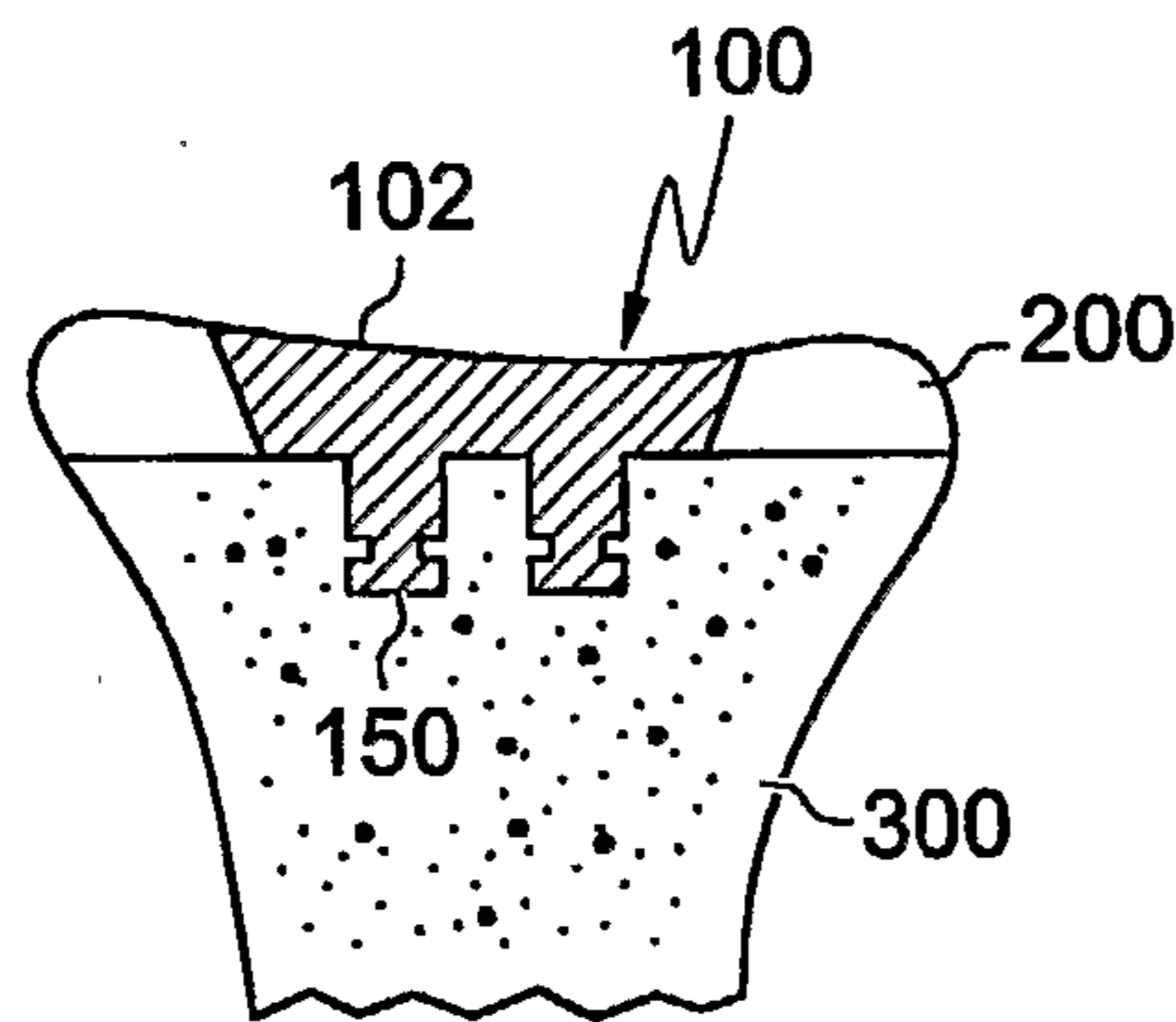

FIG. 16A

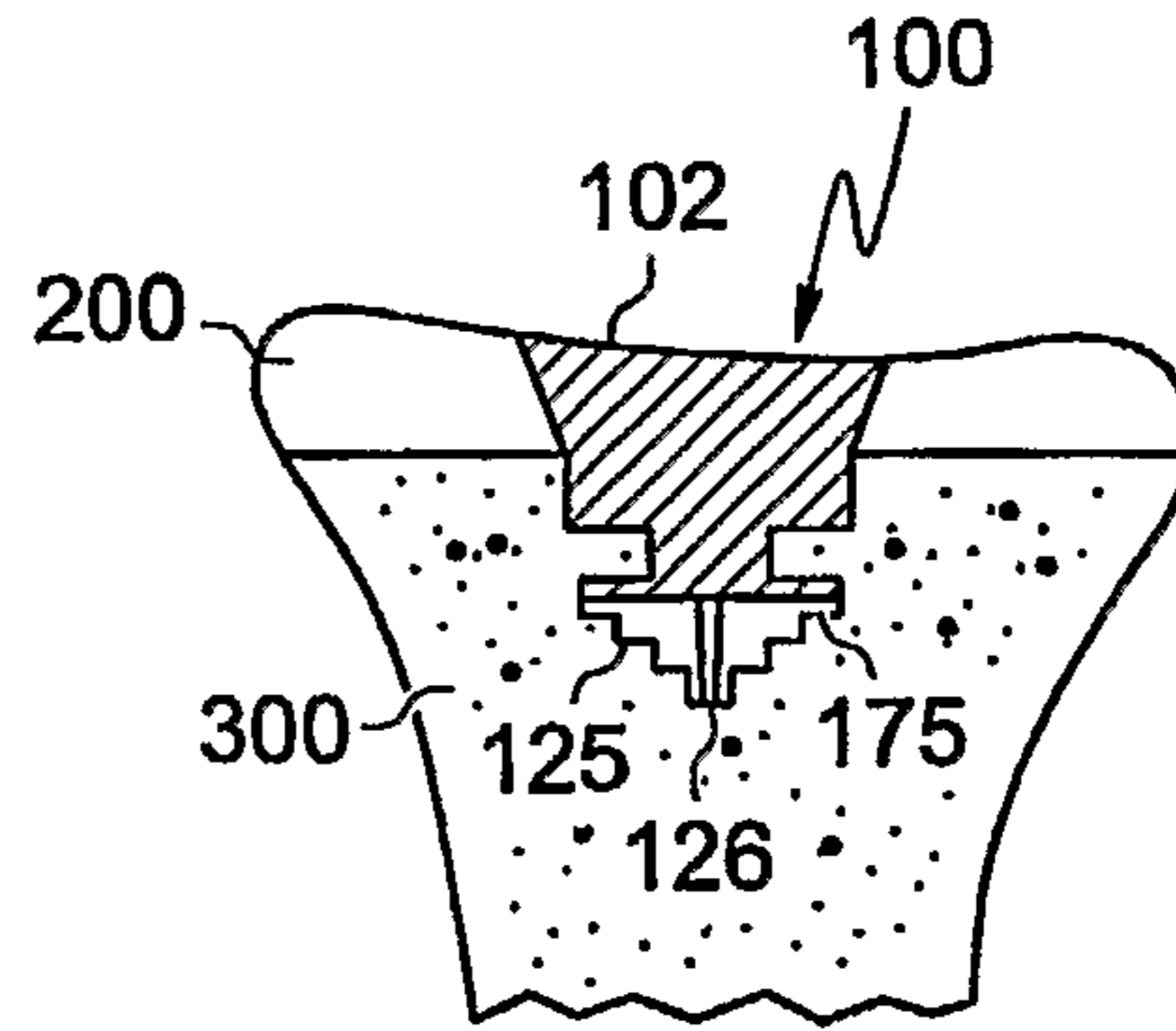

FIG. 16B

19 / 36

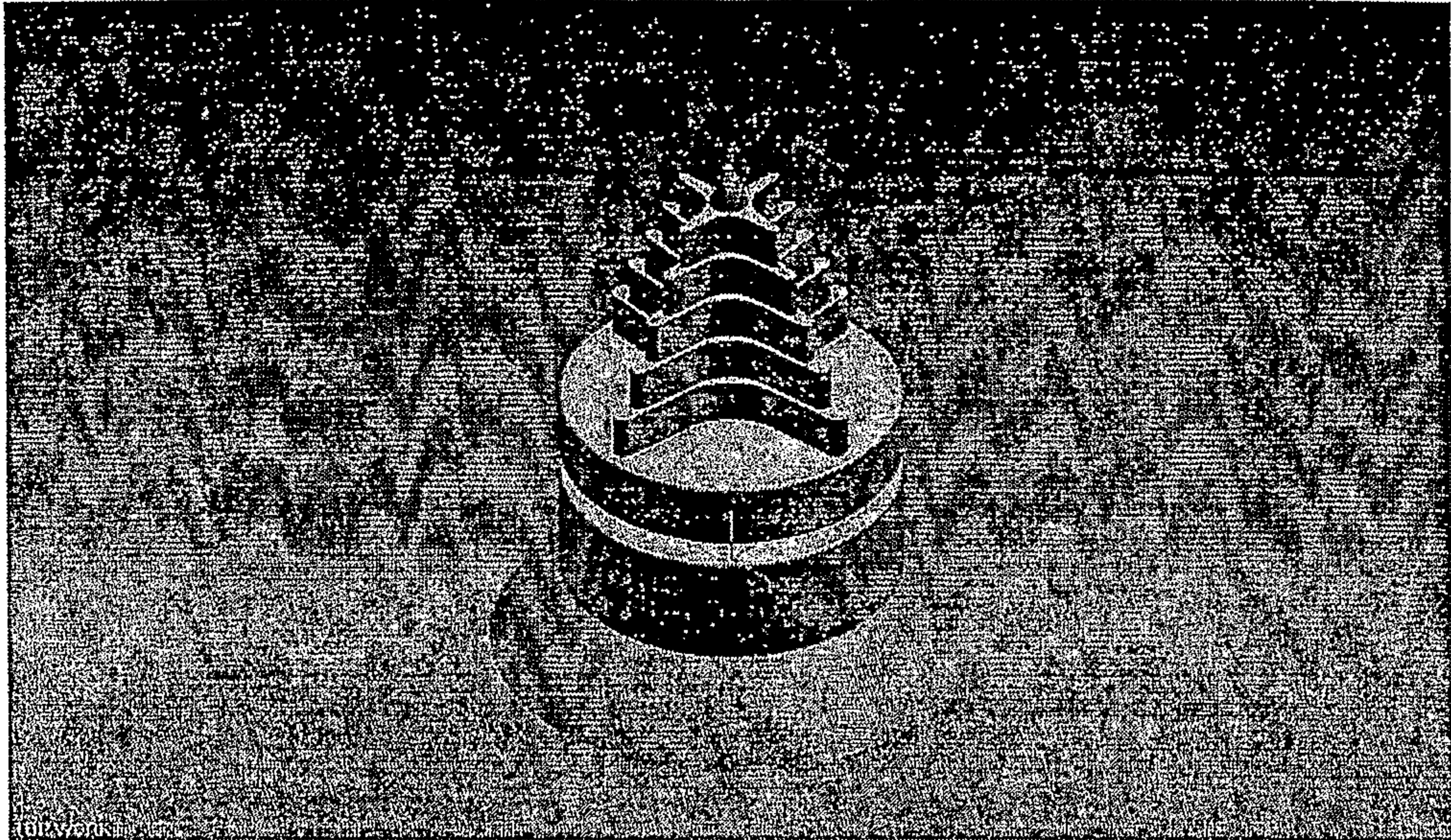

FIG. 17

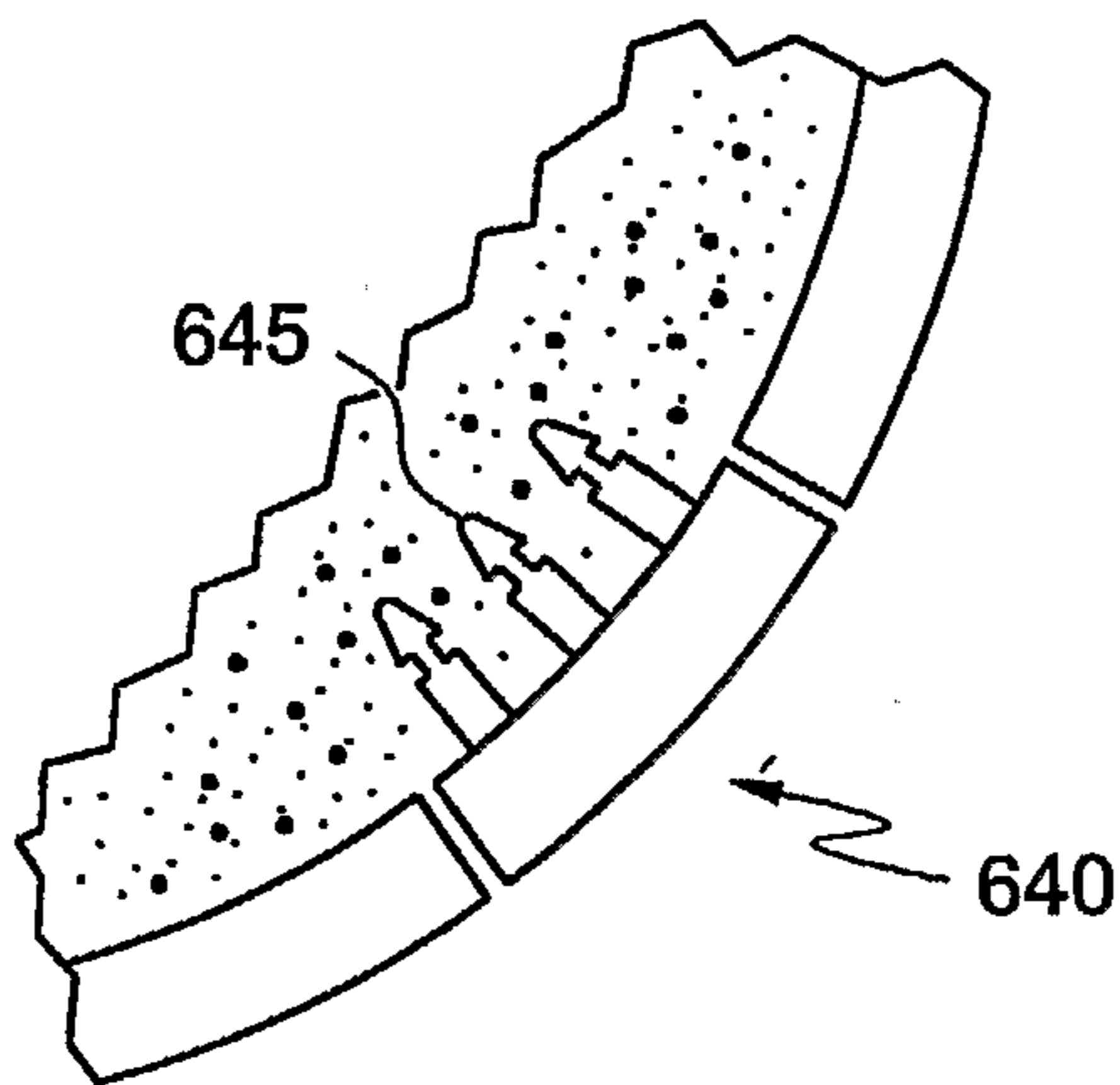

FIG. 18A

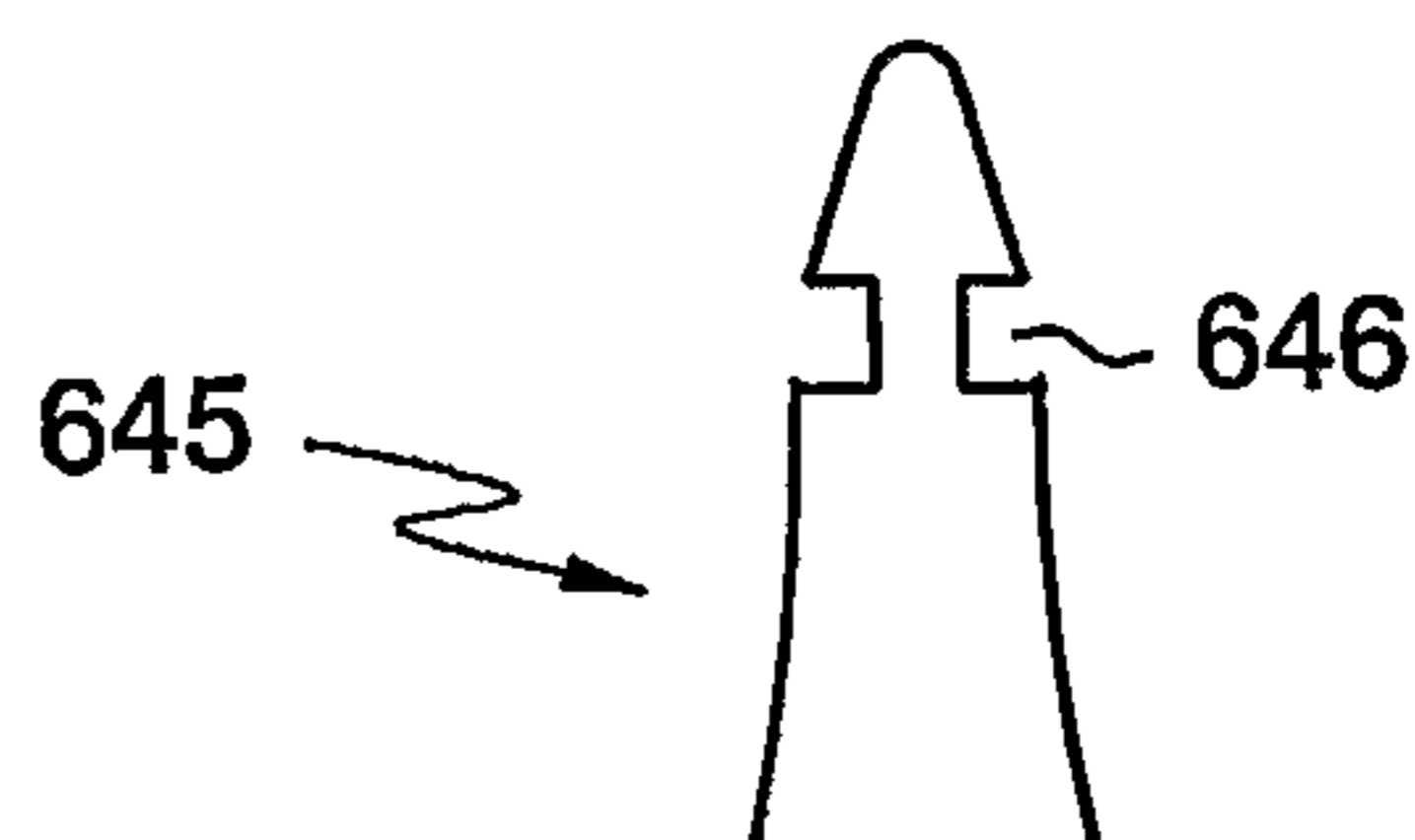

FIG. 18B



FIG. 18C

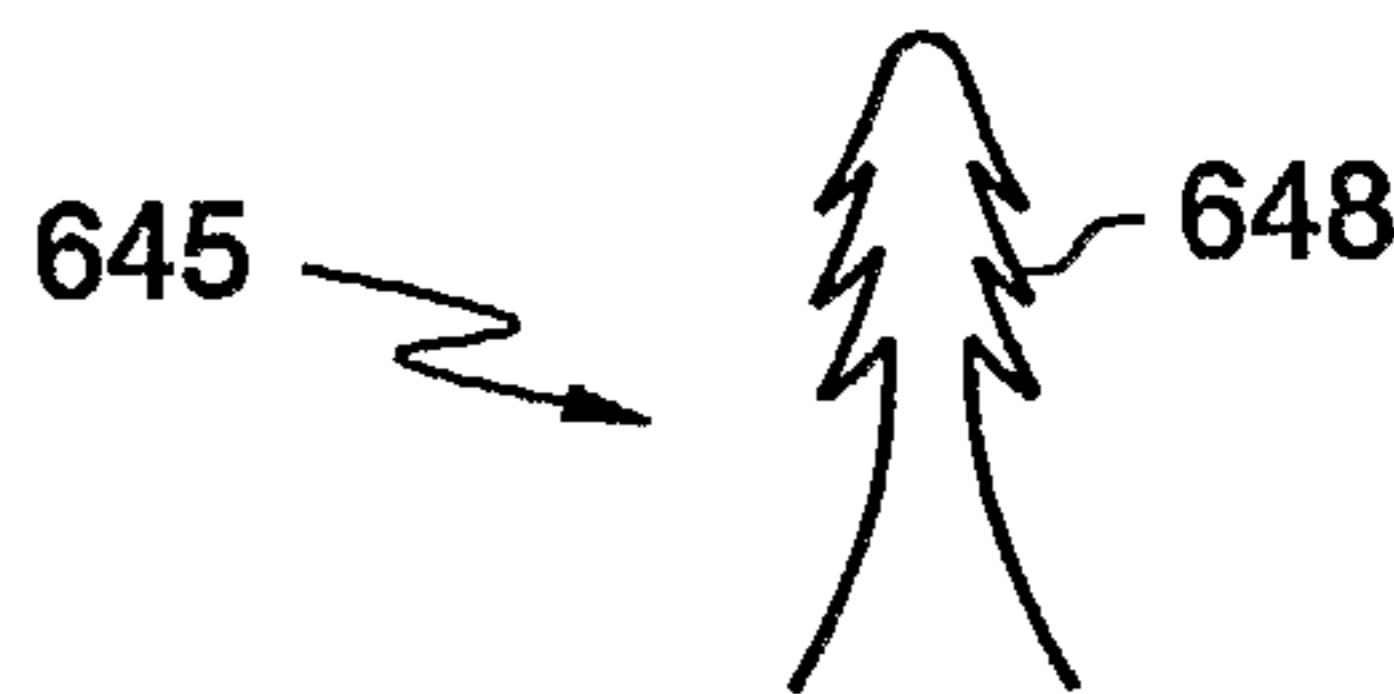

FIG. 18D

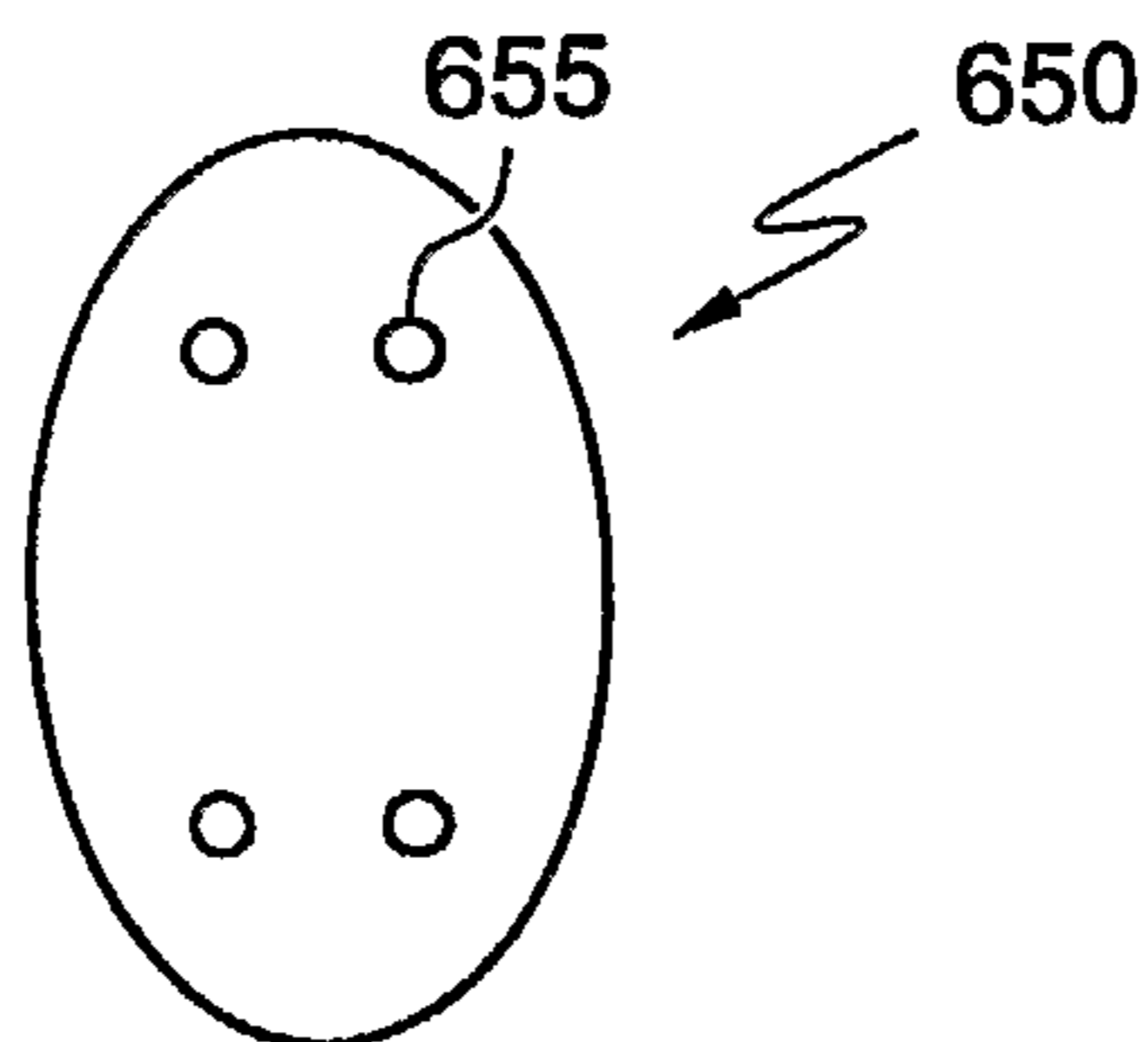

FIG. 19A

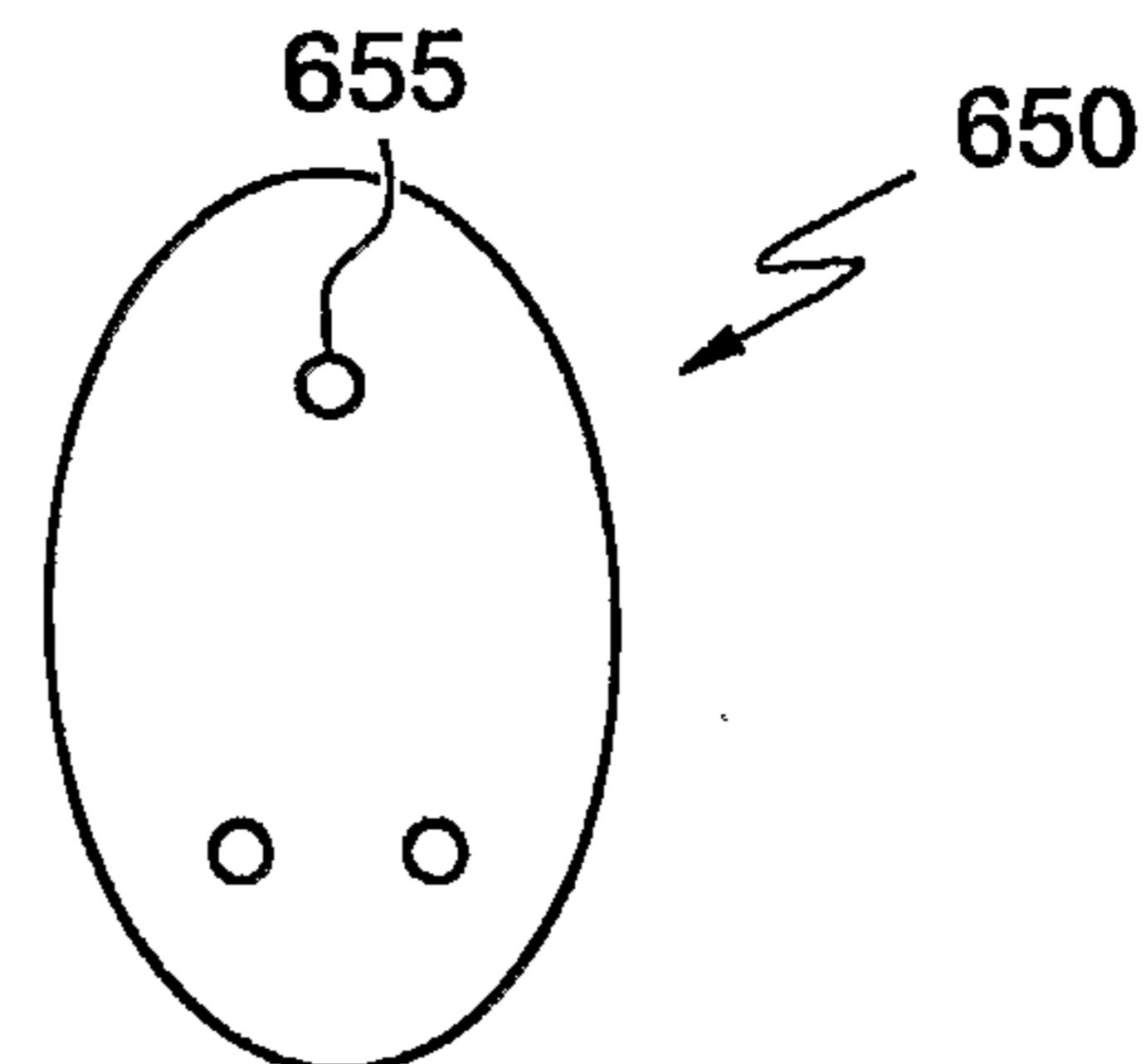

FIG. 19B

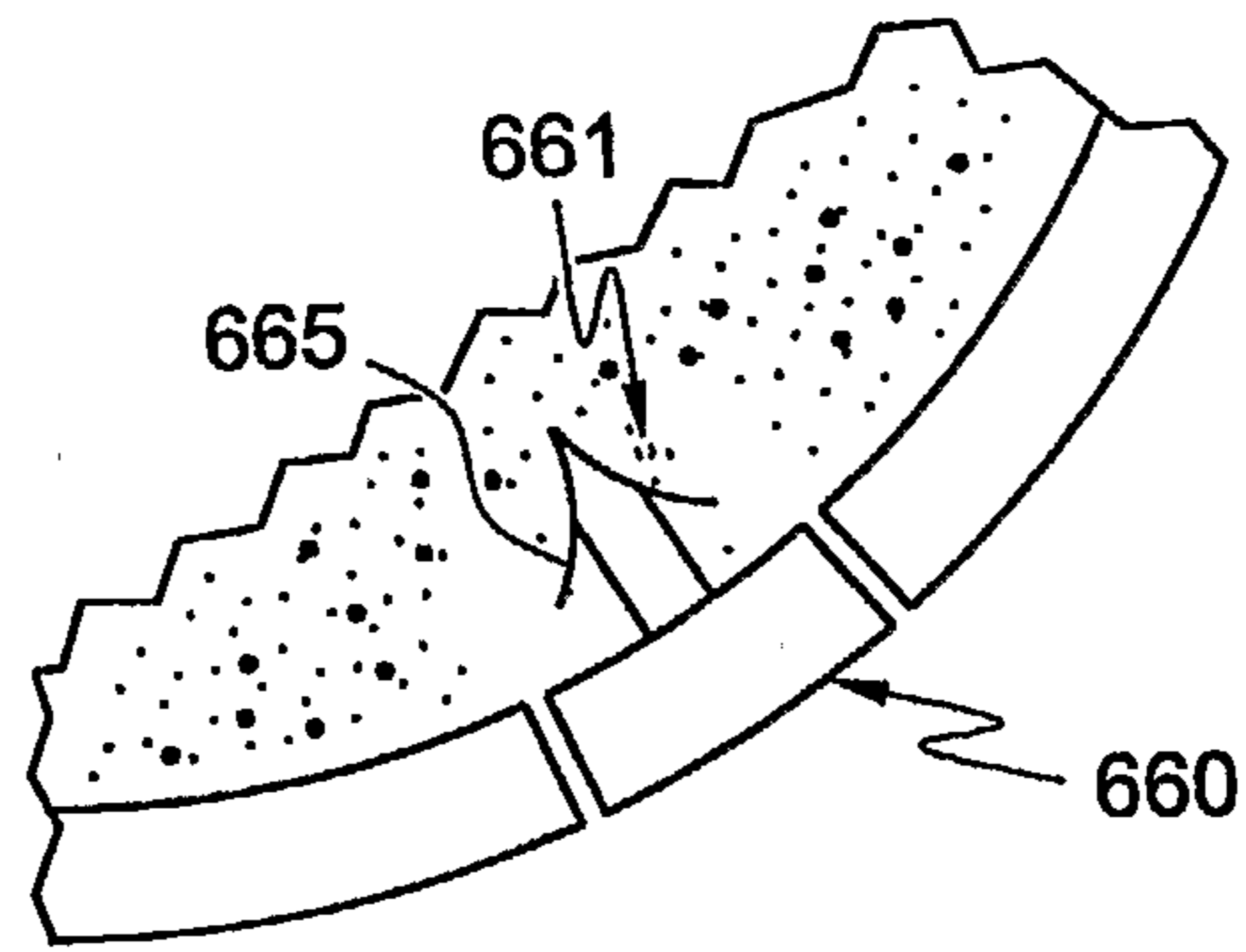

FIG. 20A

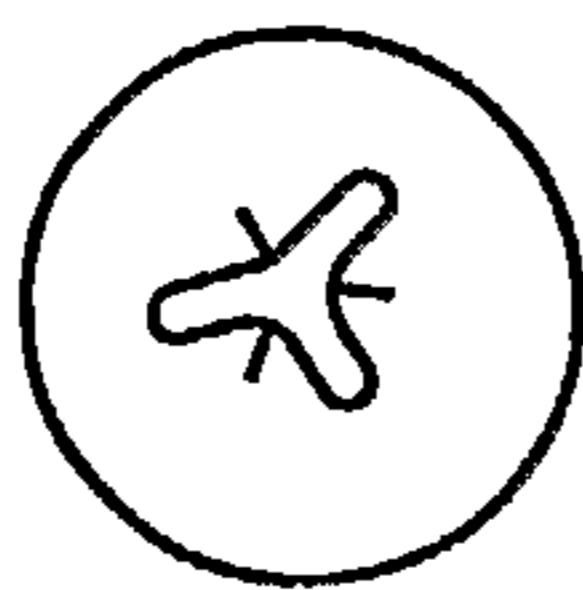

FIG. 20B

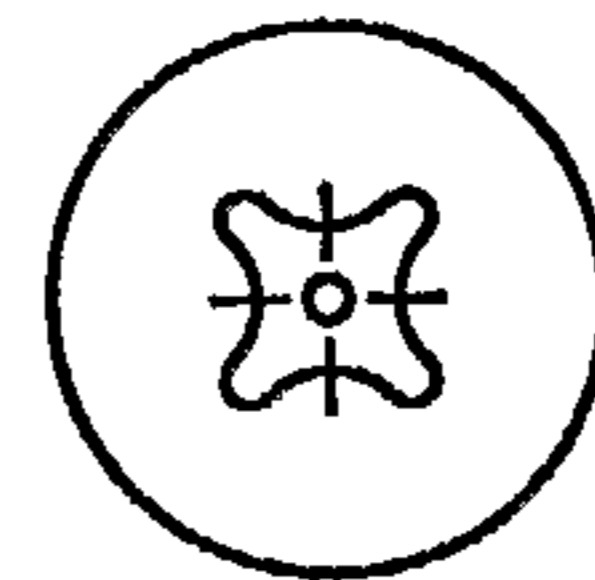

FIG. 20C

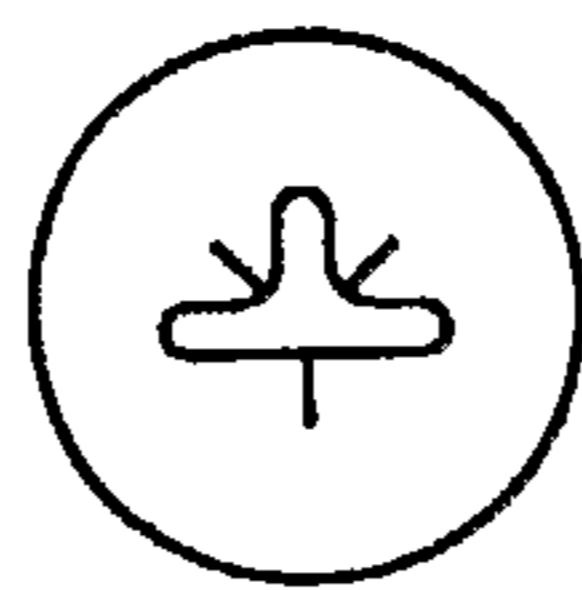

FIG. 20D

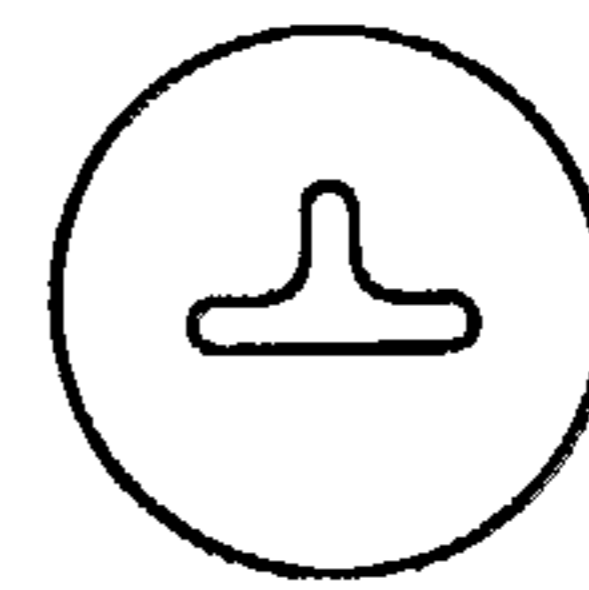

FIG. 20E

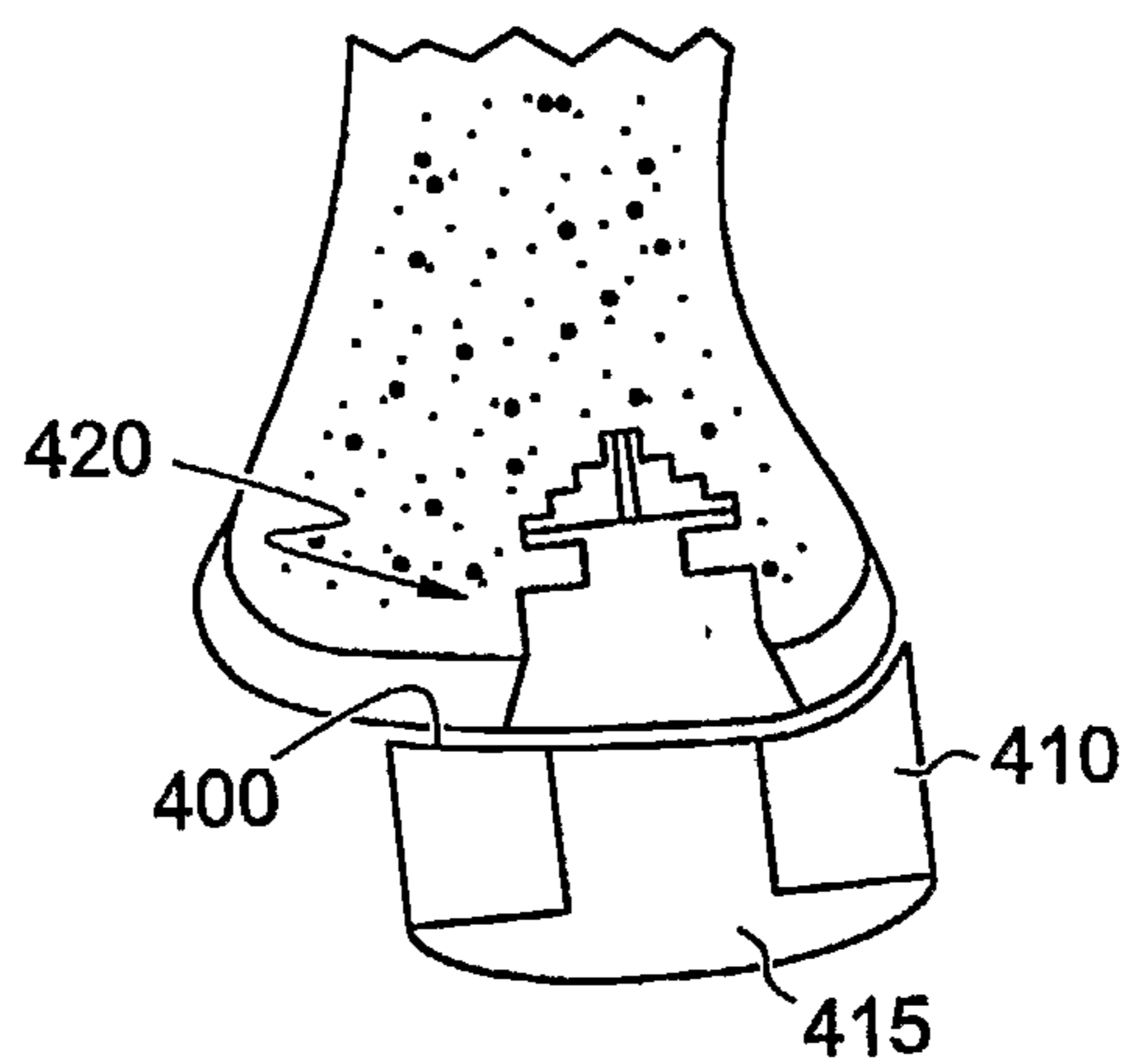
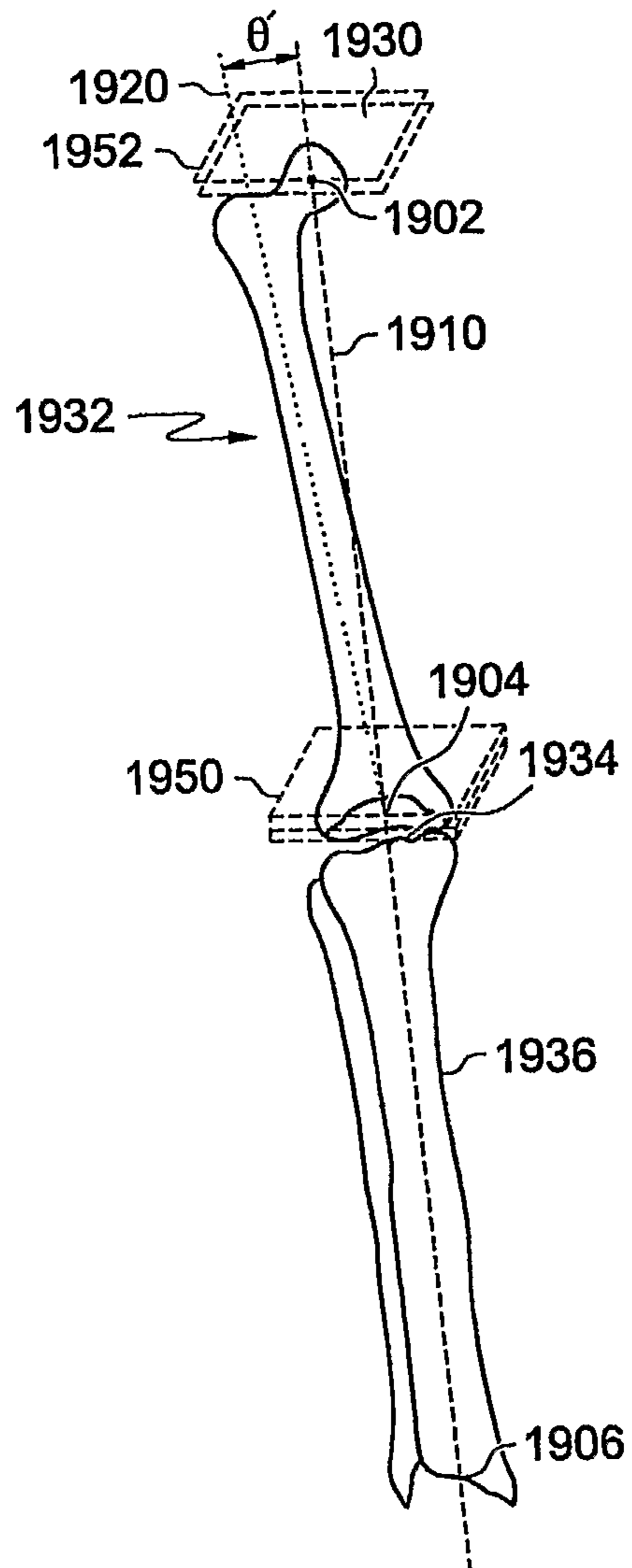

FIG. 22

22 / 36

**FIG. 21A**

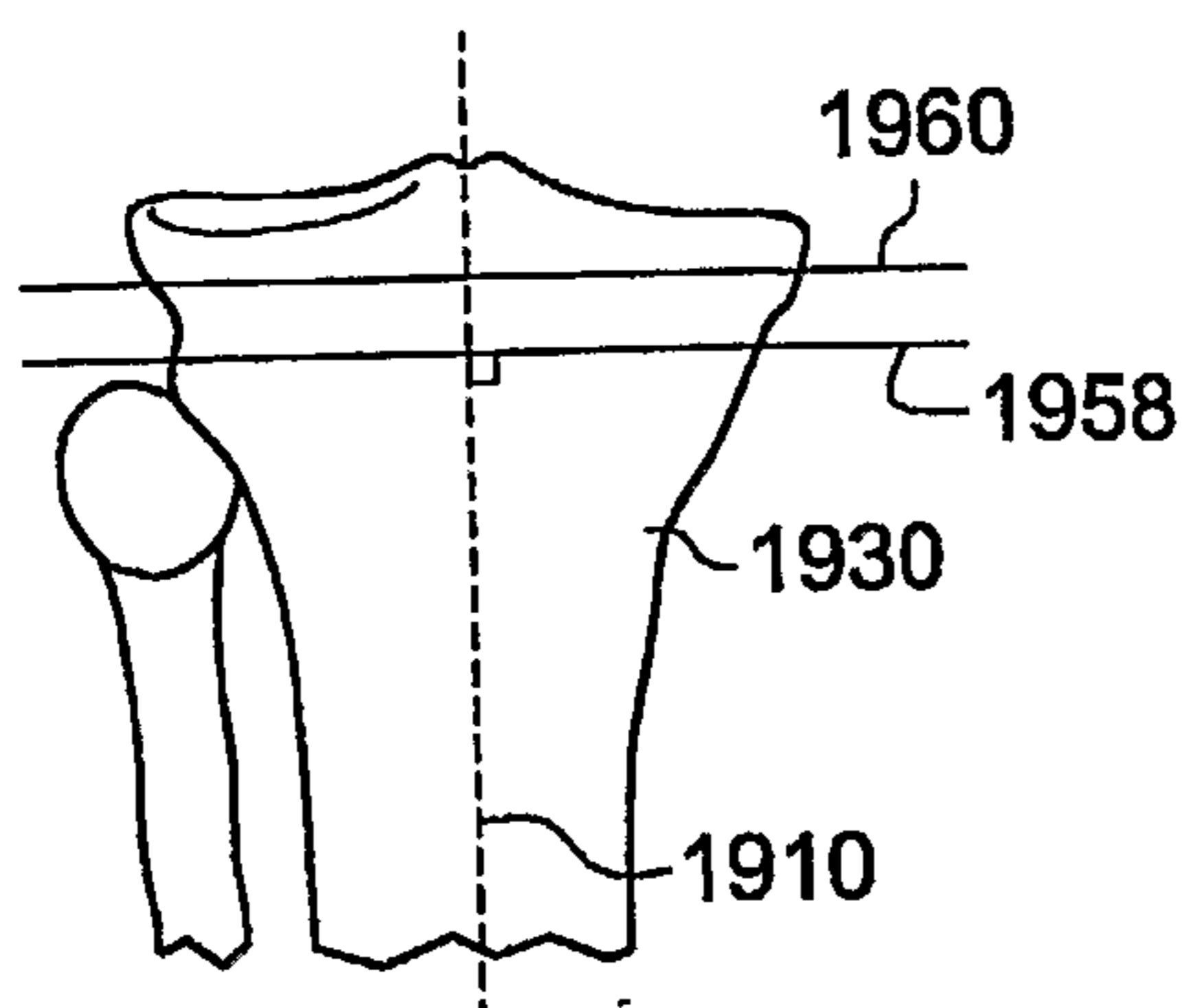

FIG. 21B

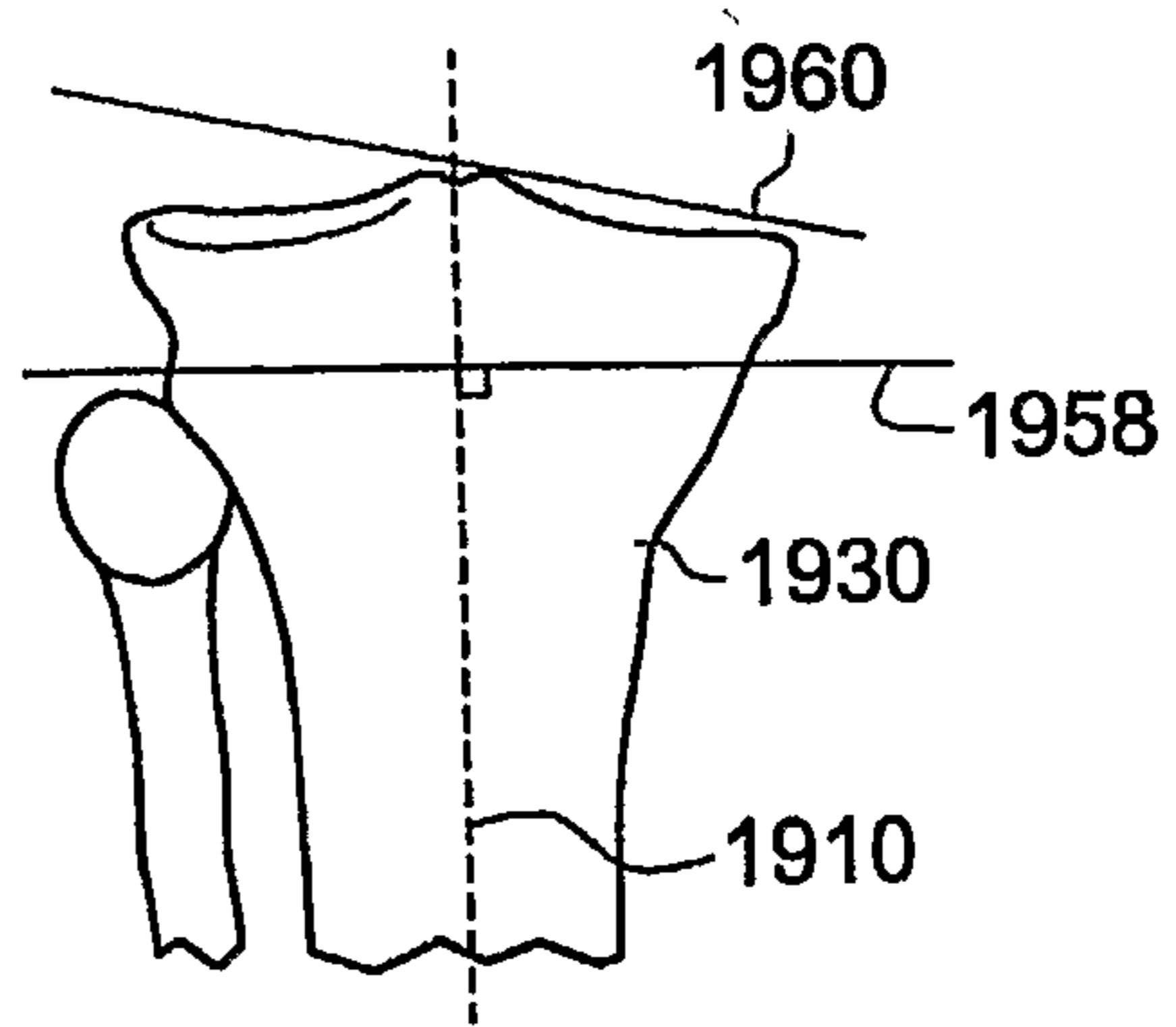

FIG. 21C

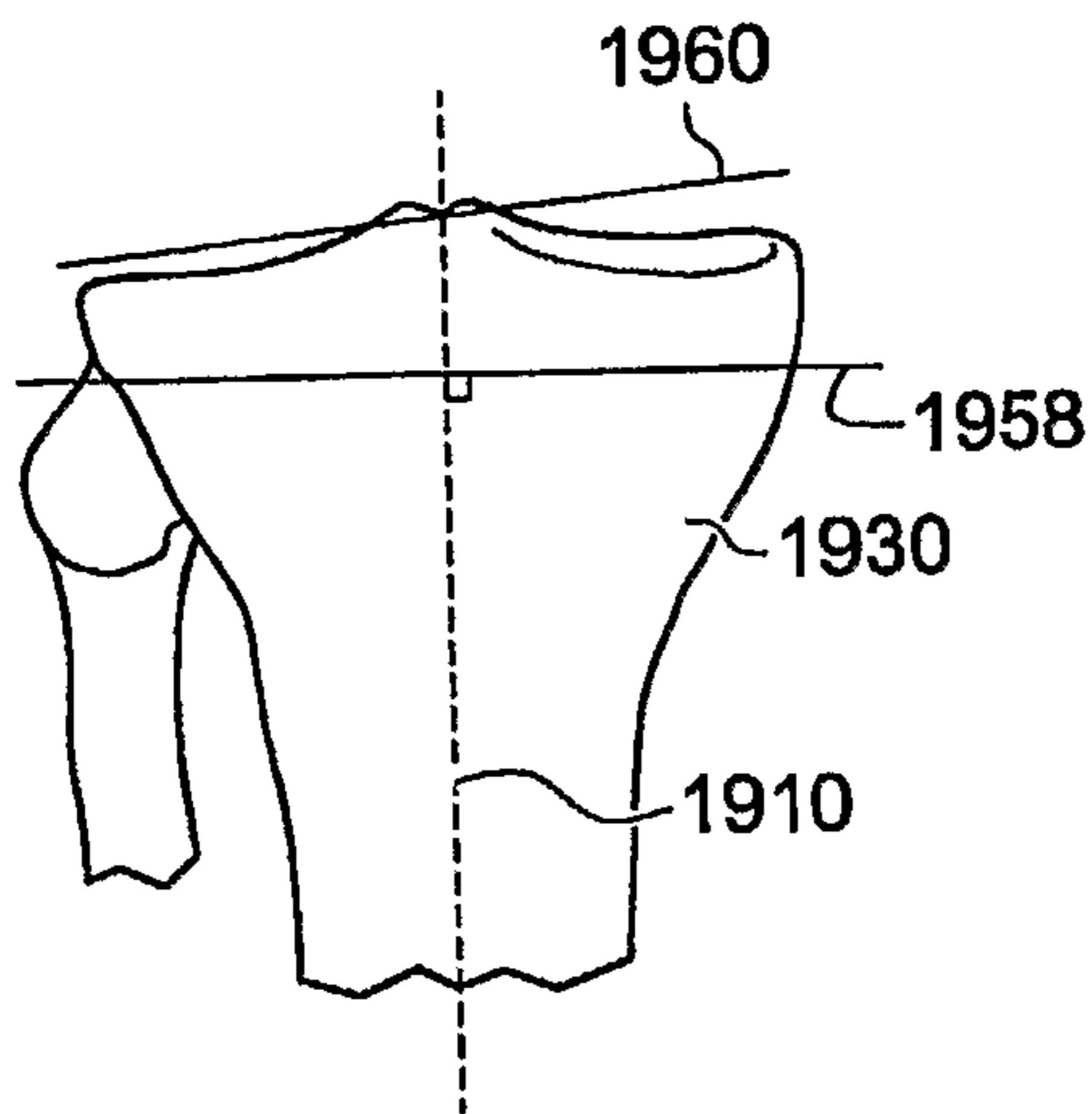

FIG. 21D

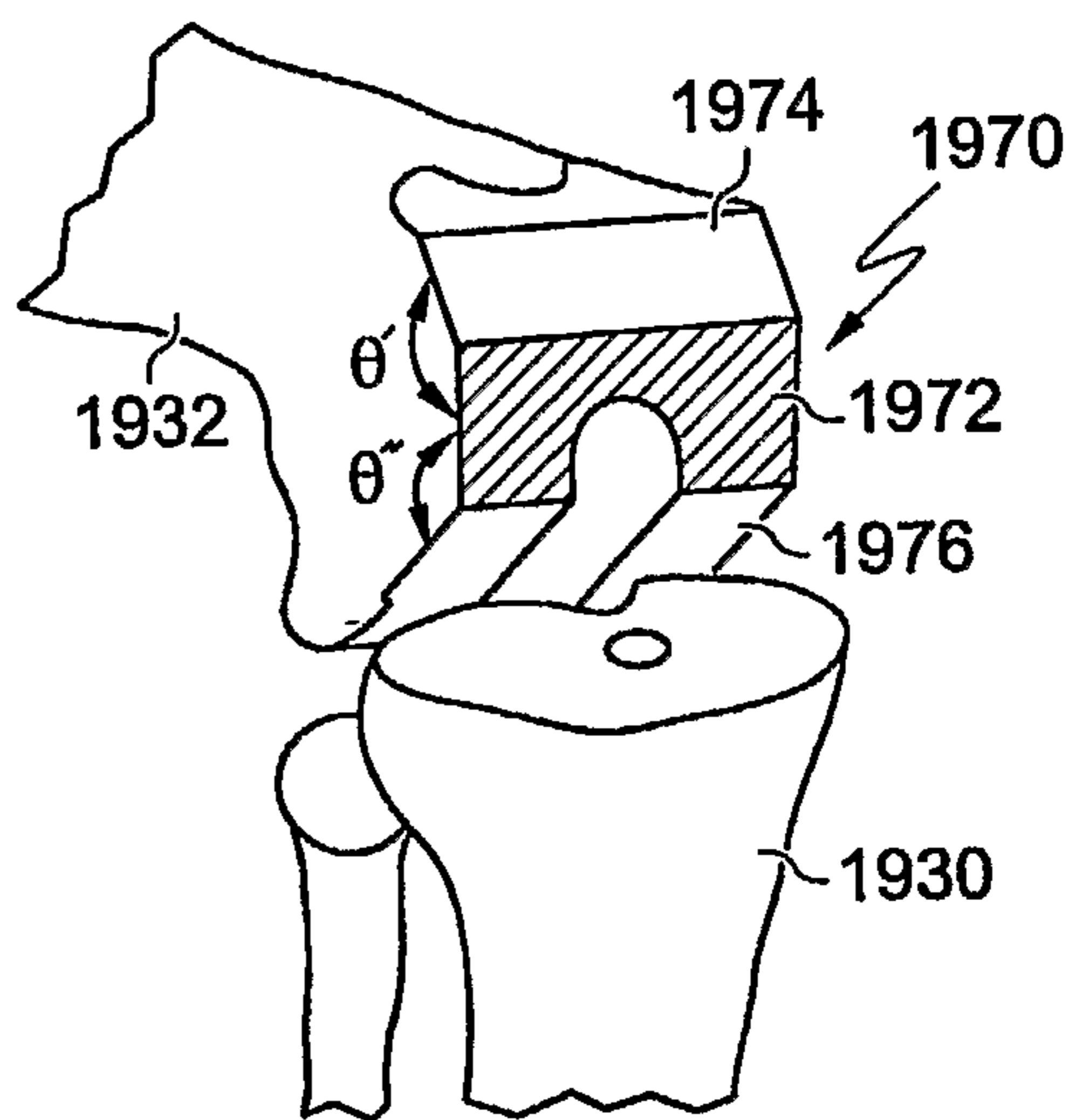

FIG. 21E

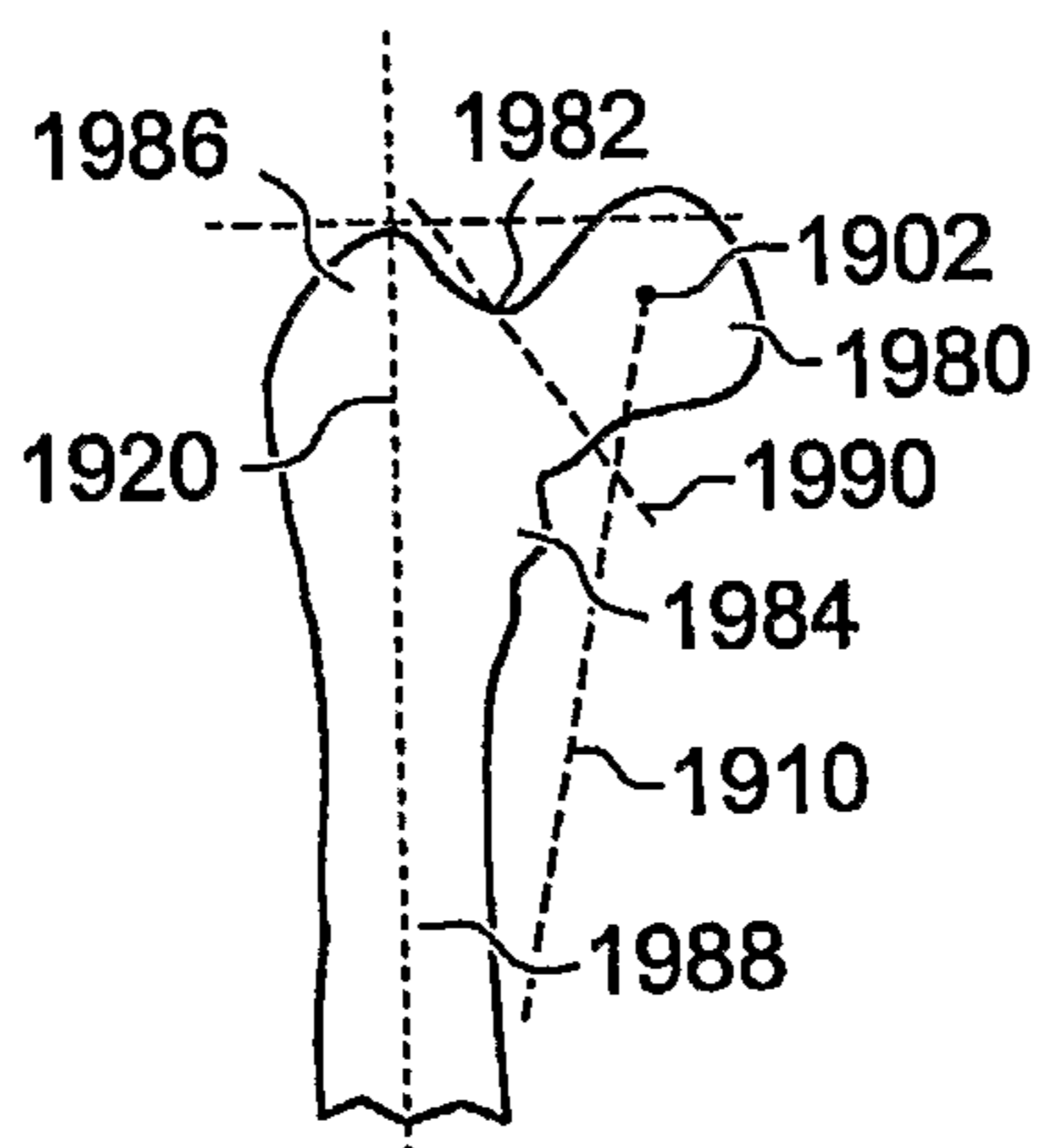

FIG. 21F

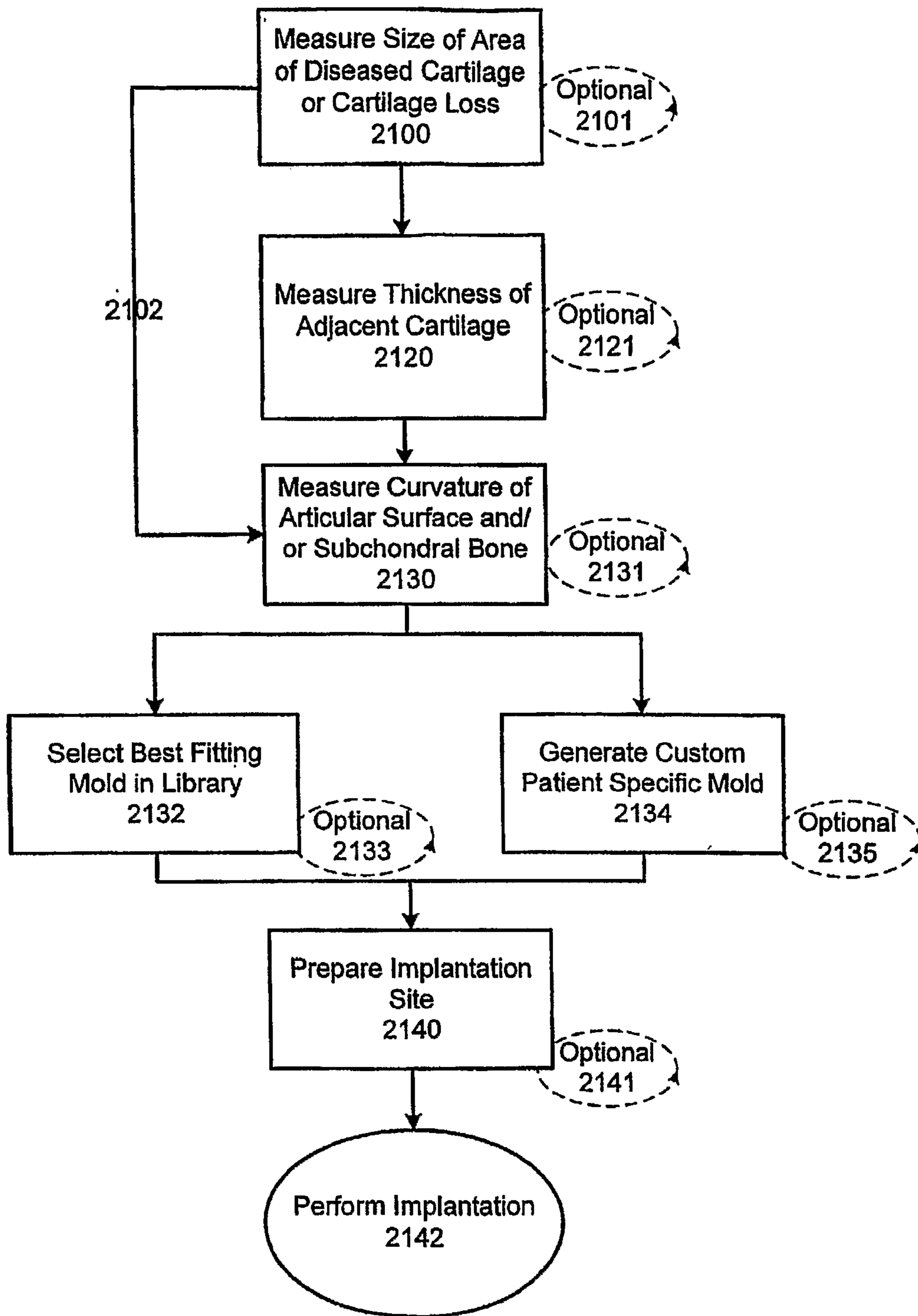

FIG. 23

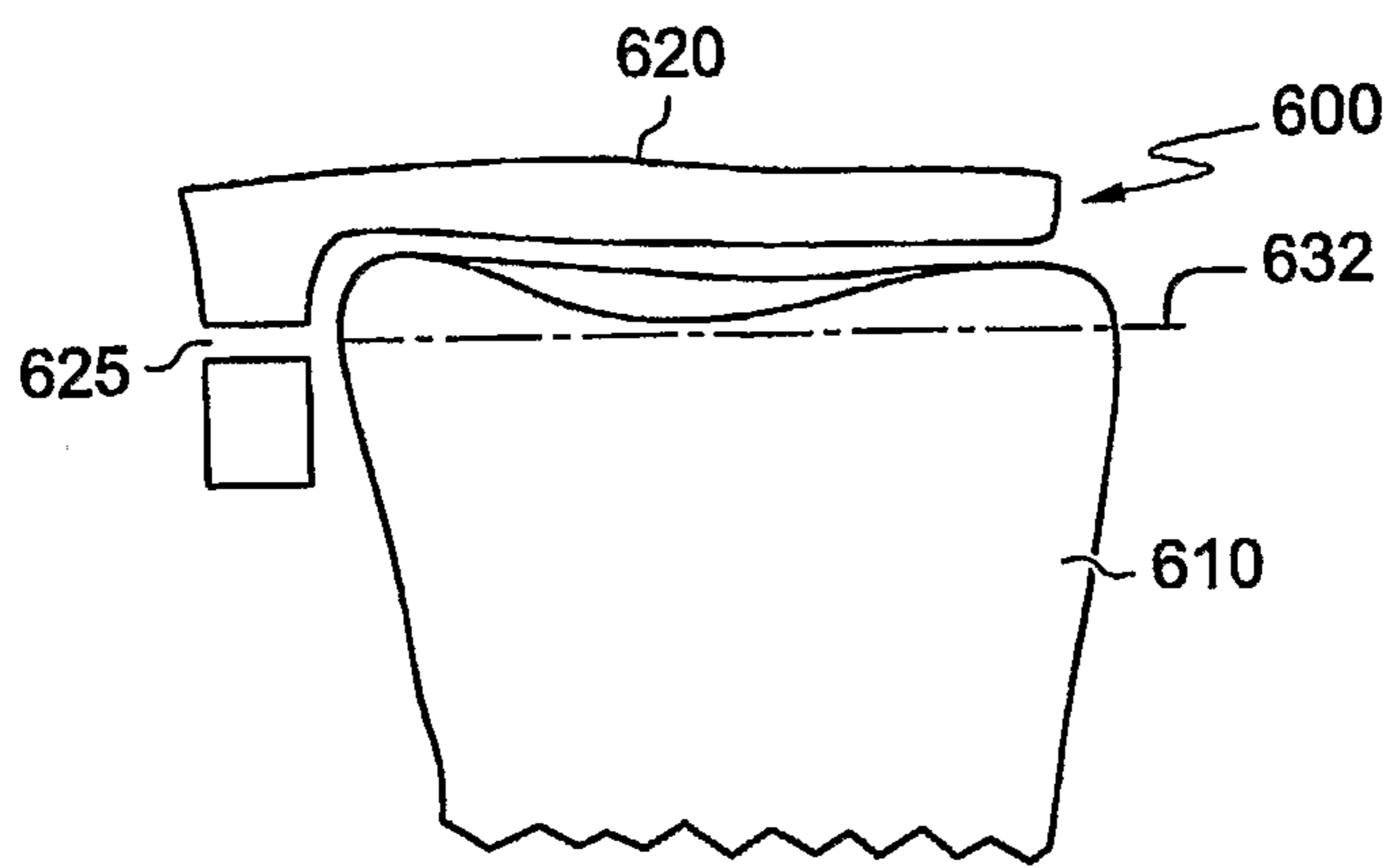

FIG. 24A

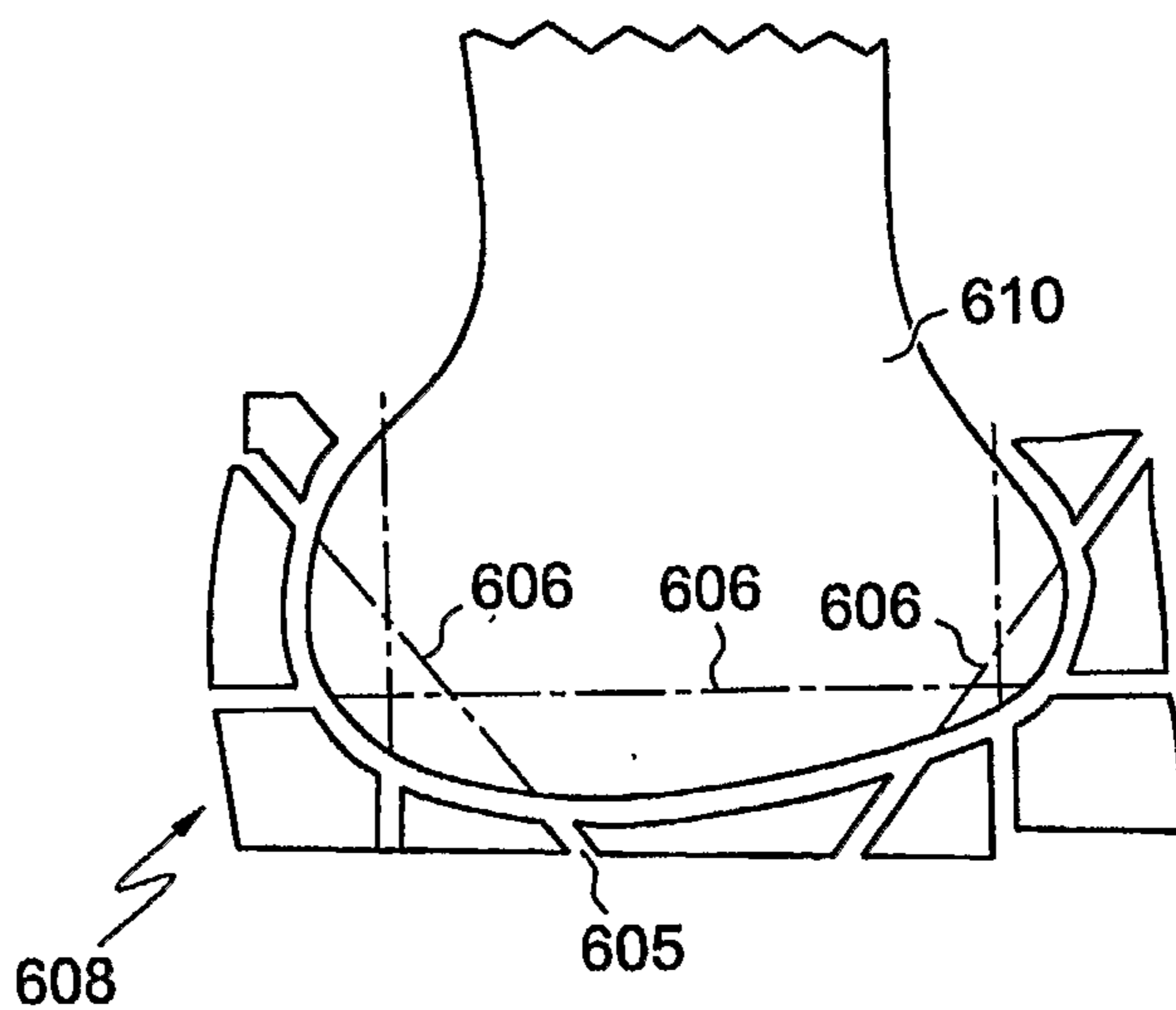

FIG. 24B

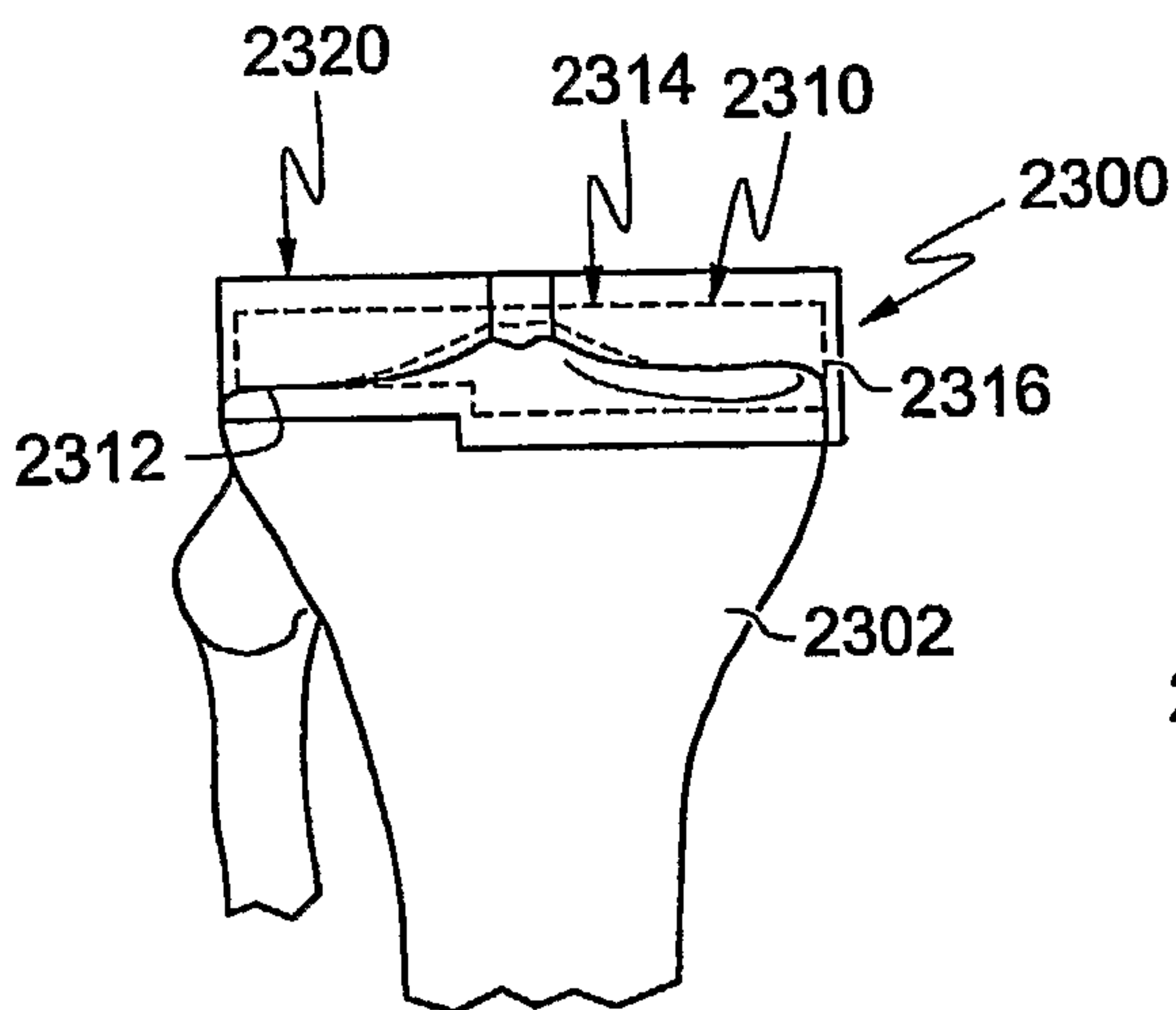

FIG. 25A

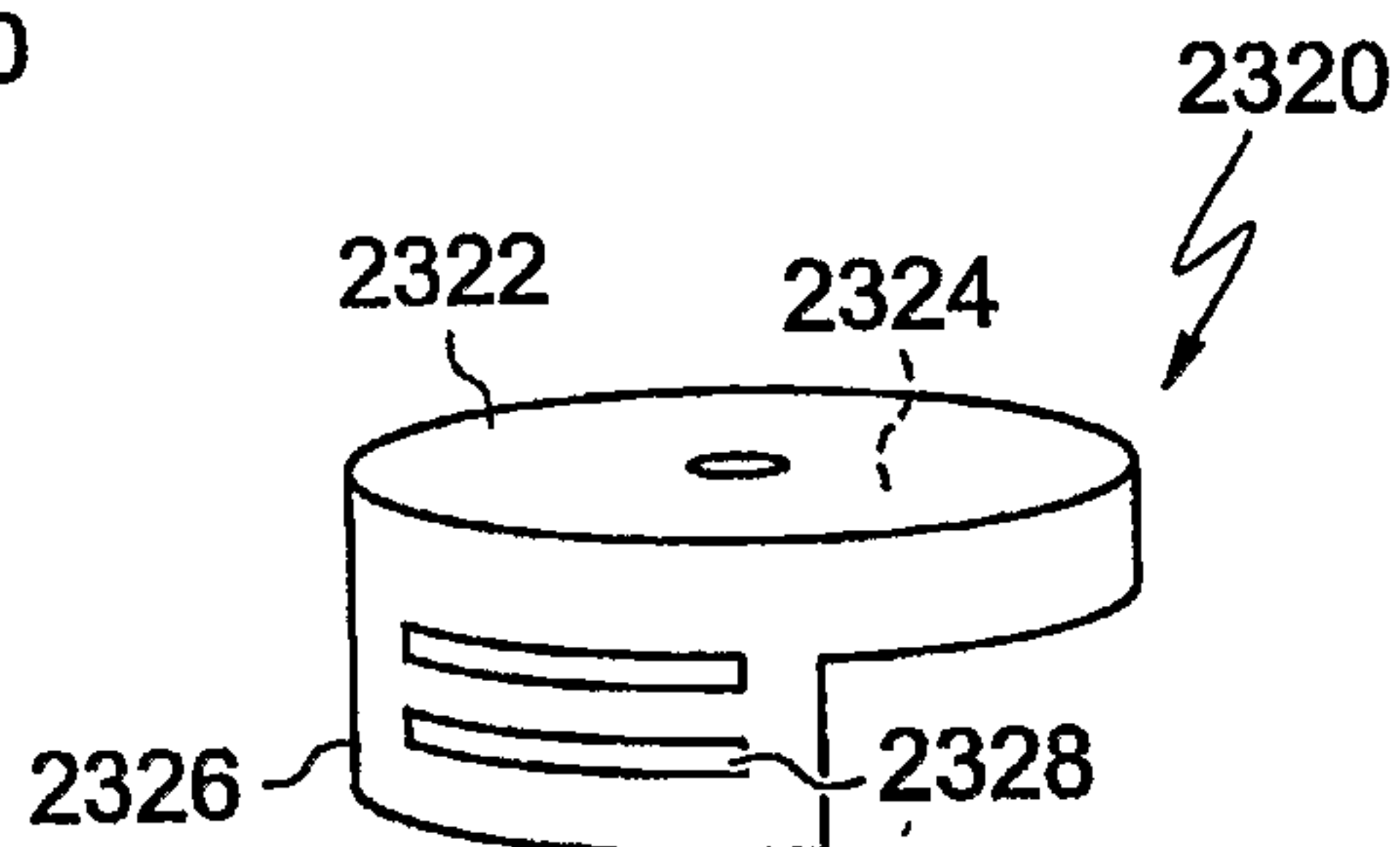

FIG. 25B

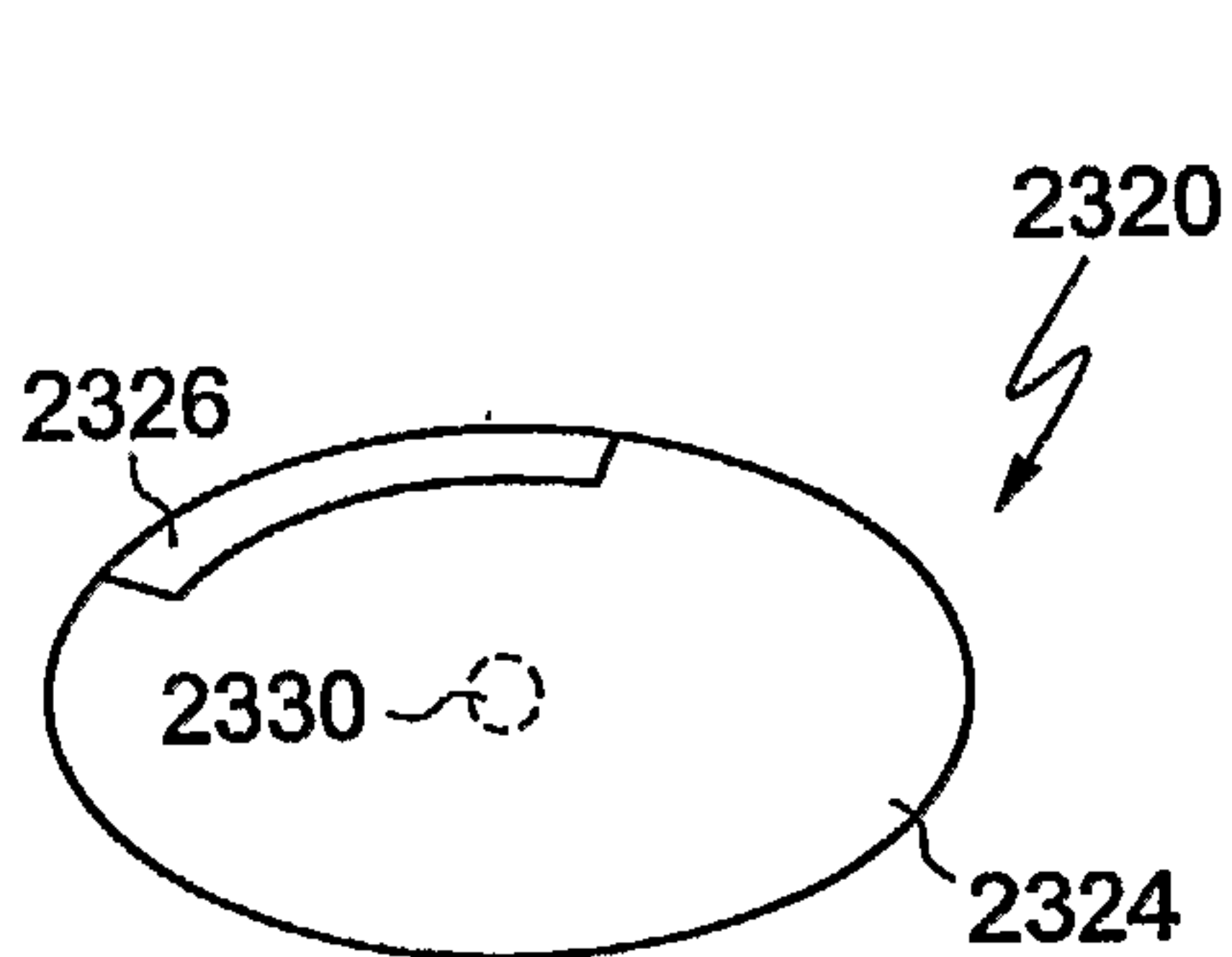

FIG. 25C

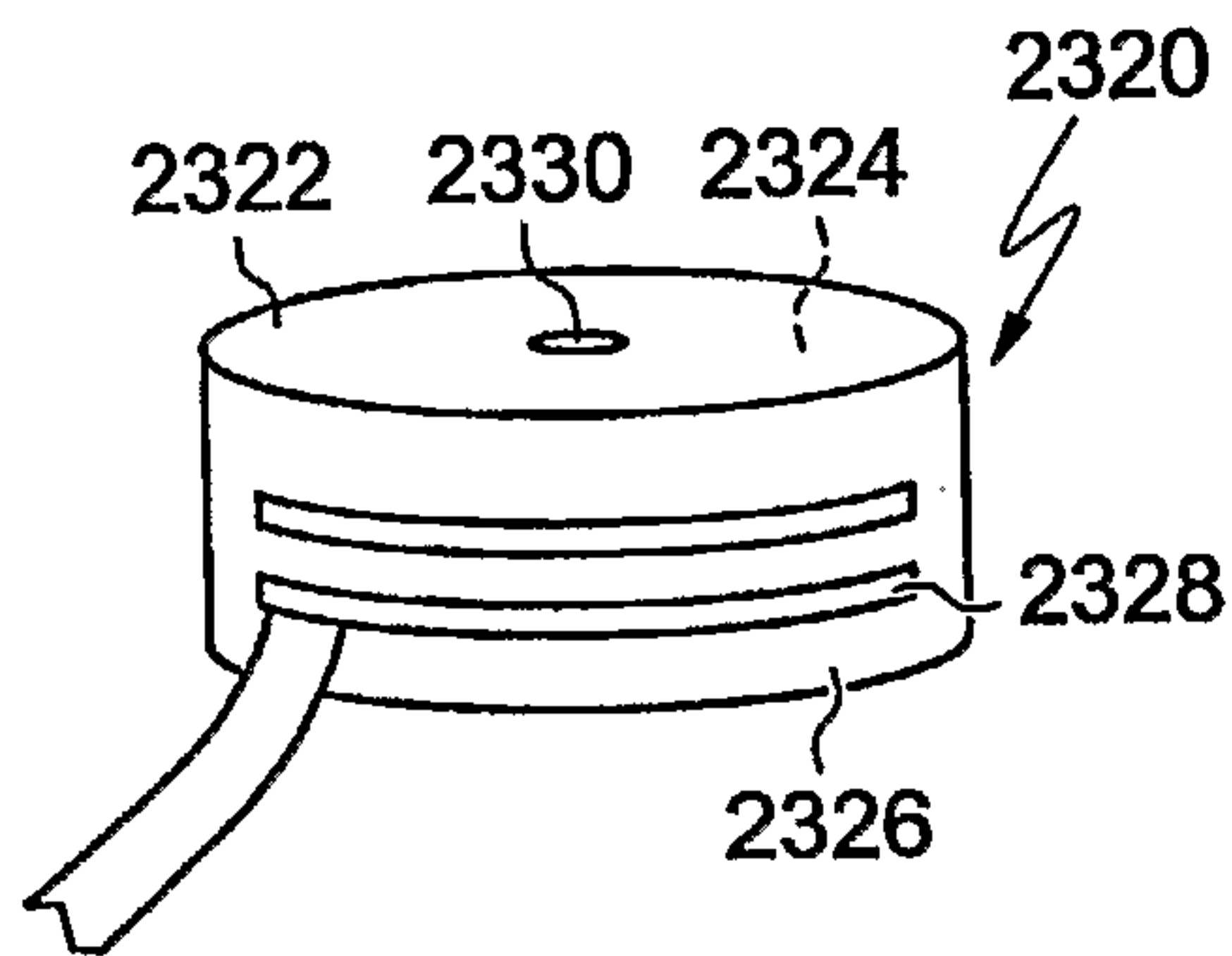

FIG. 25D

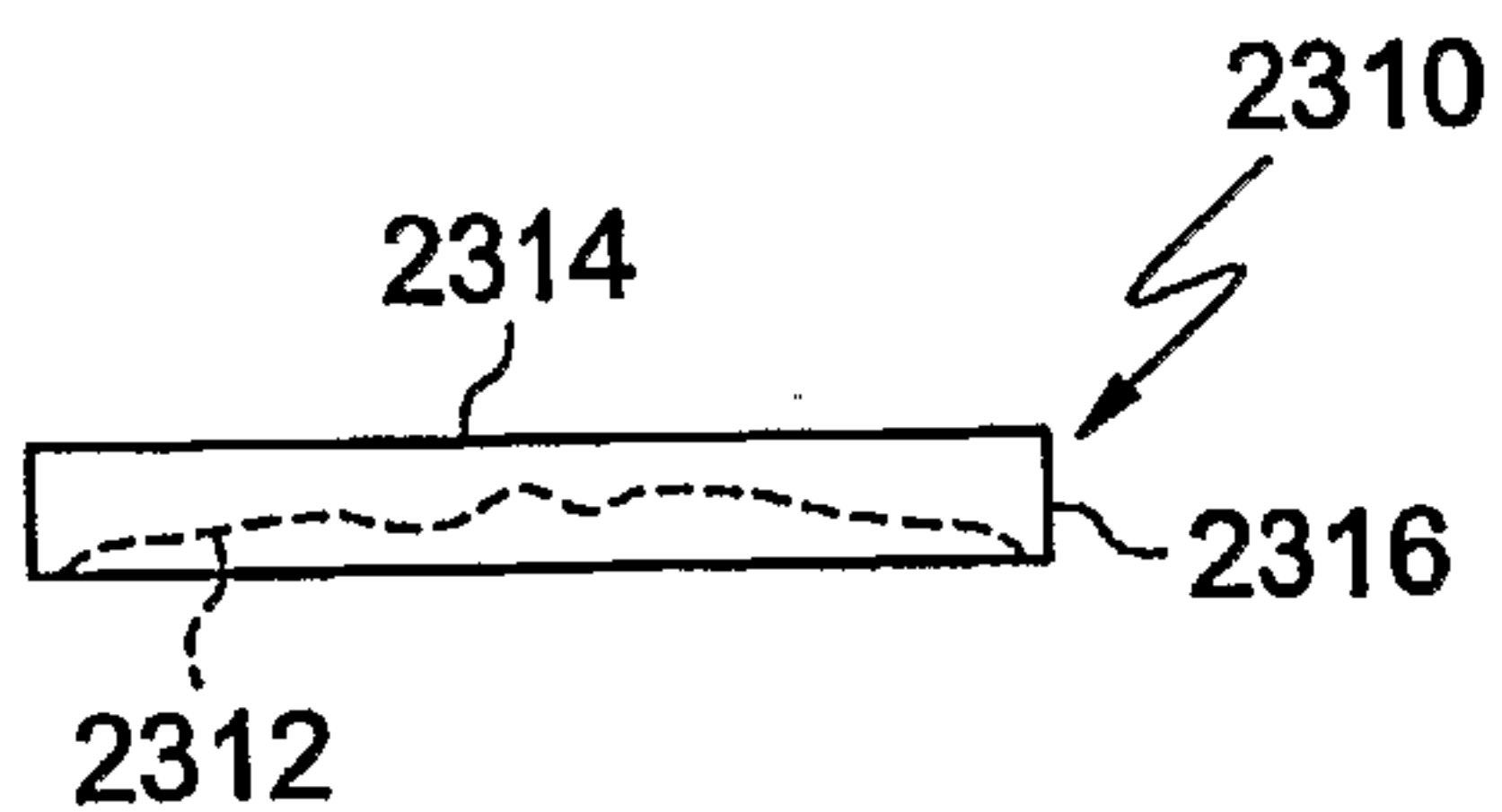

FIG. 25E

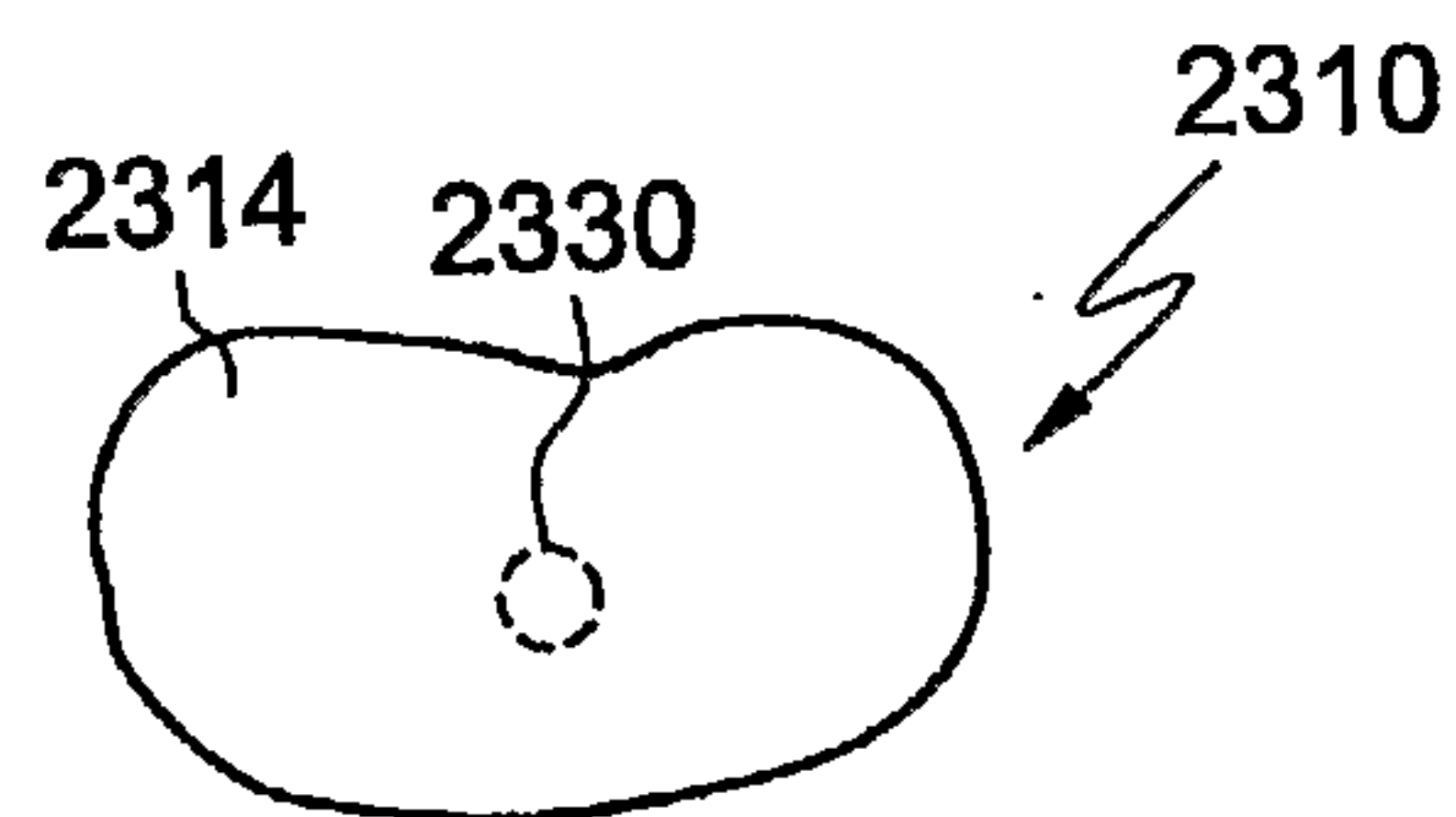

FIG. 25F

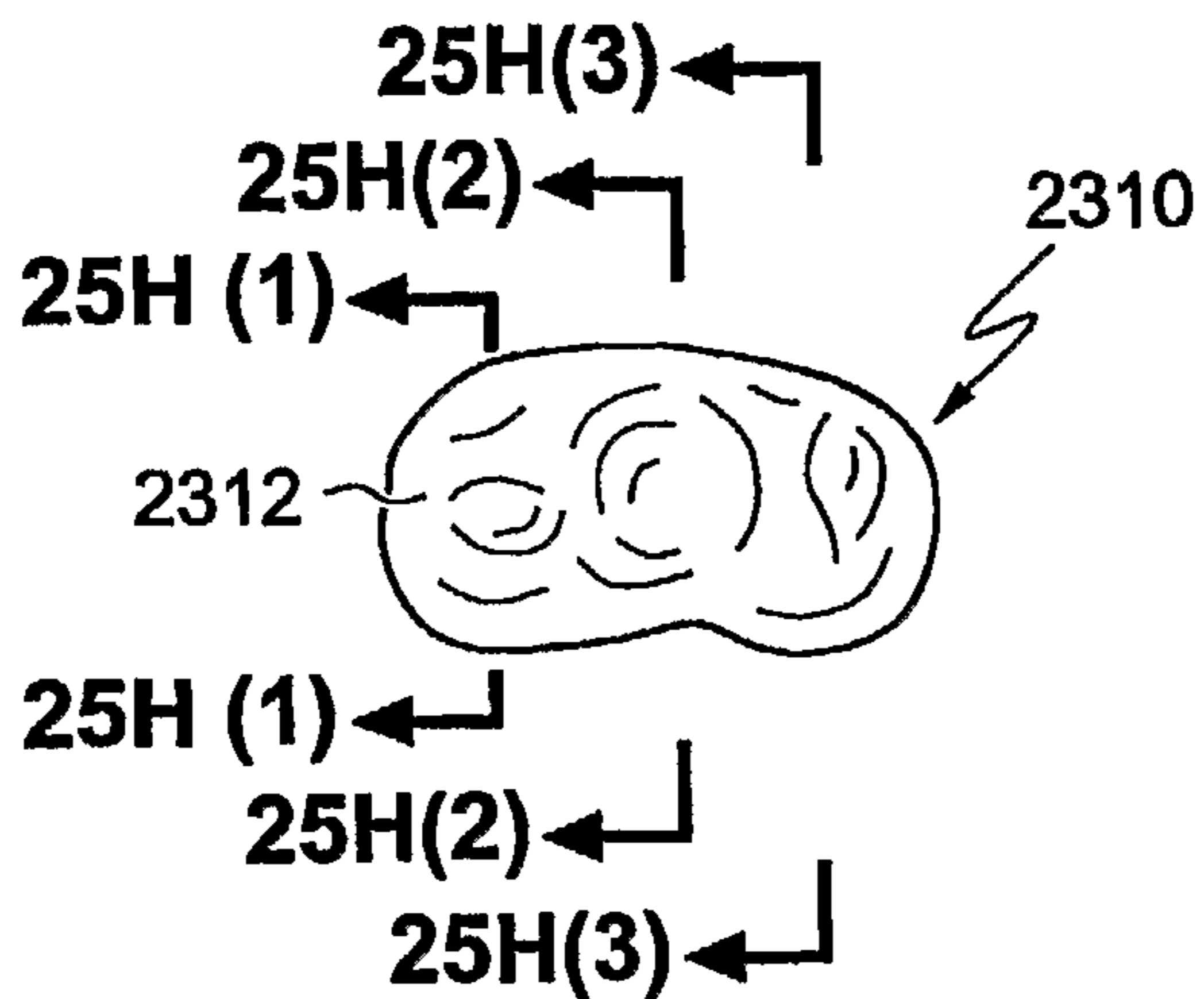

FIG. 25G

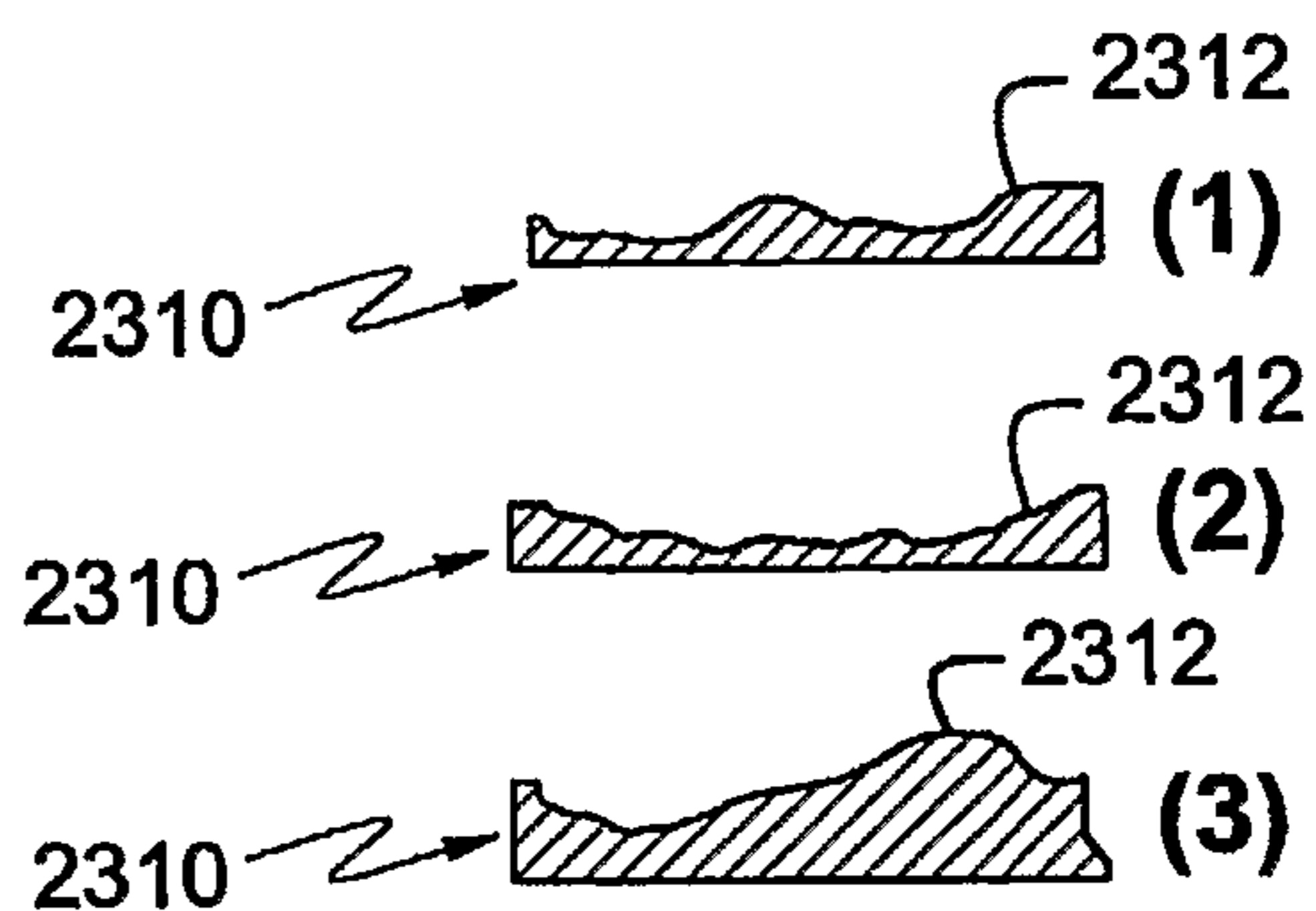

FIG. 25H

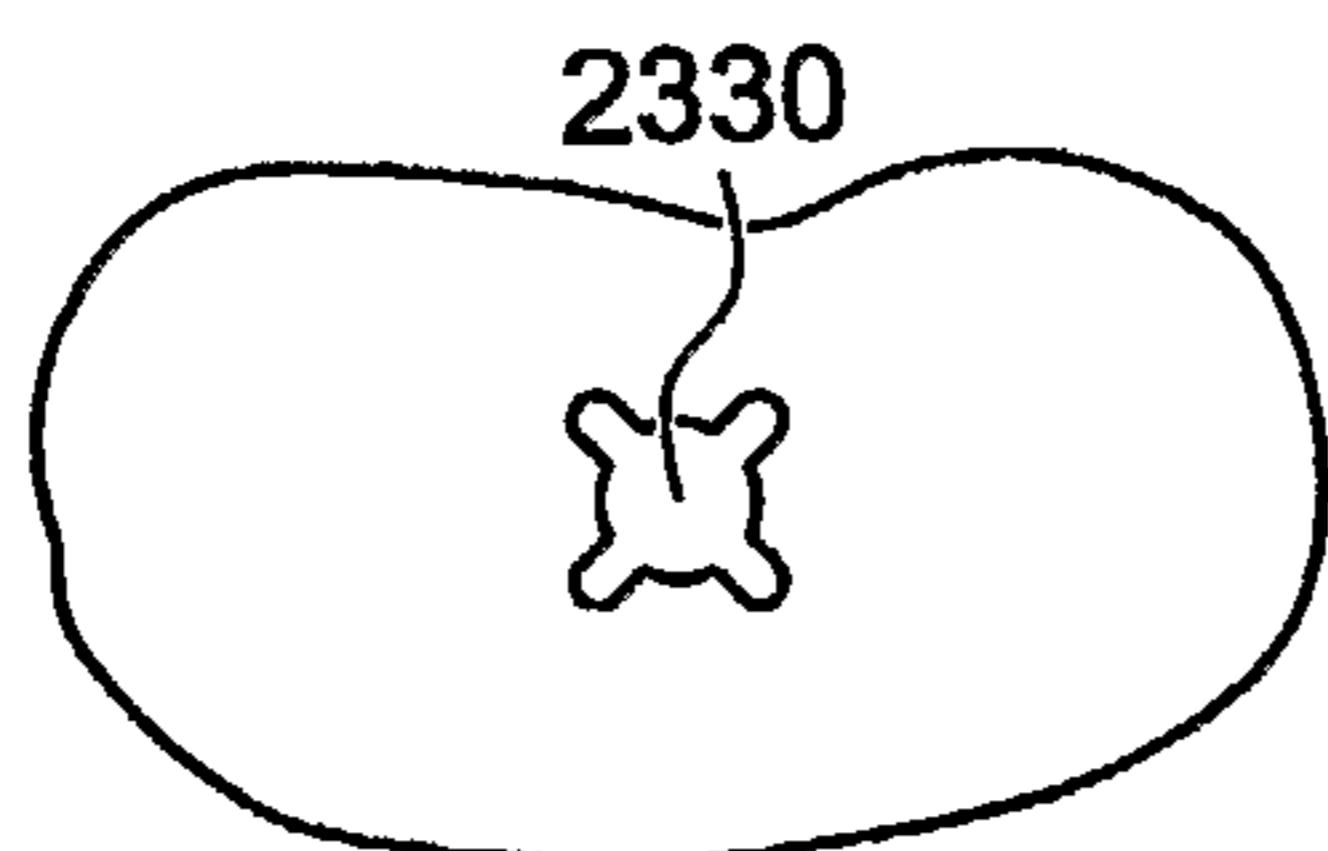

FIG. 25I

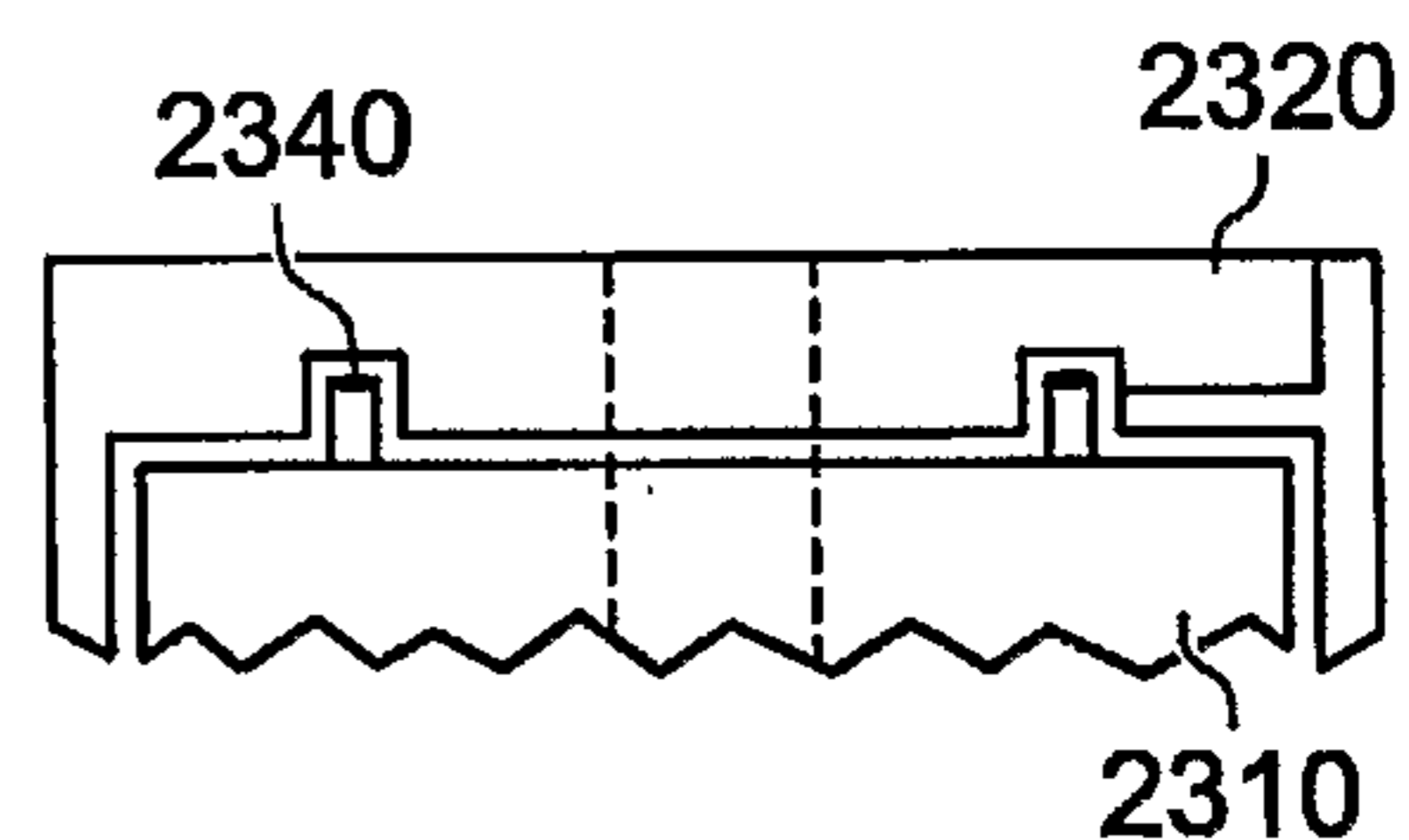

FIG. 25J

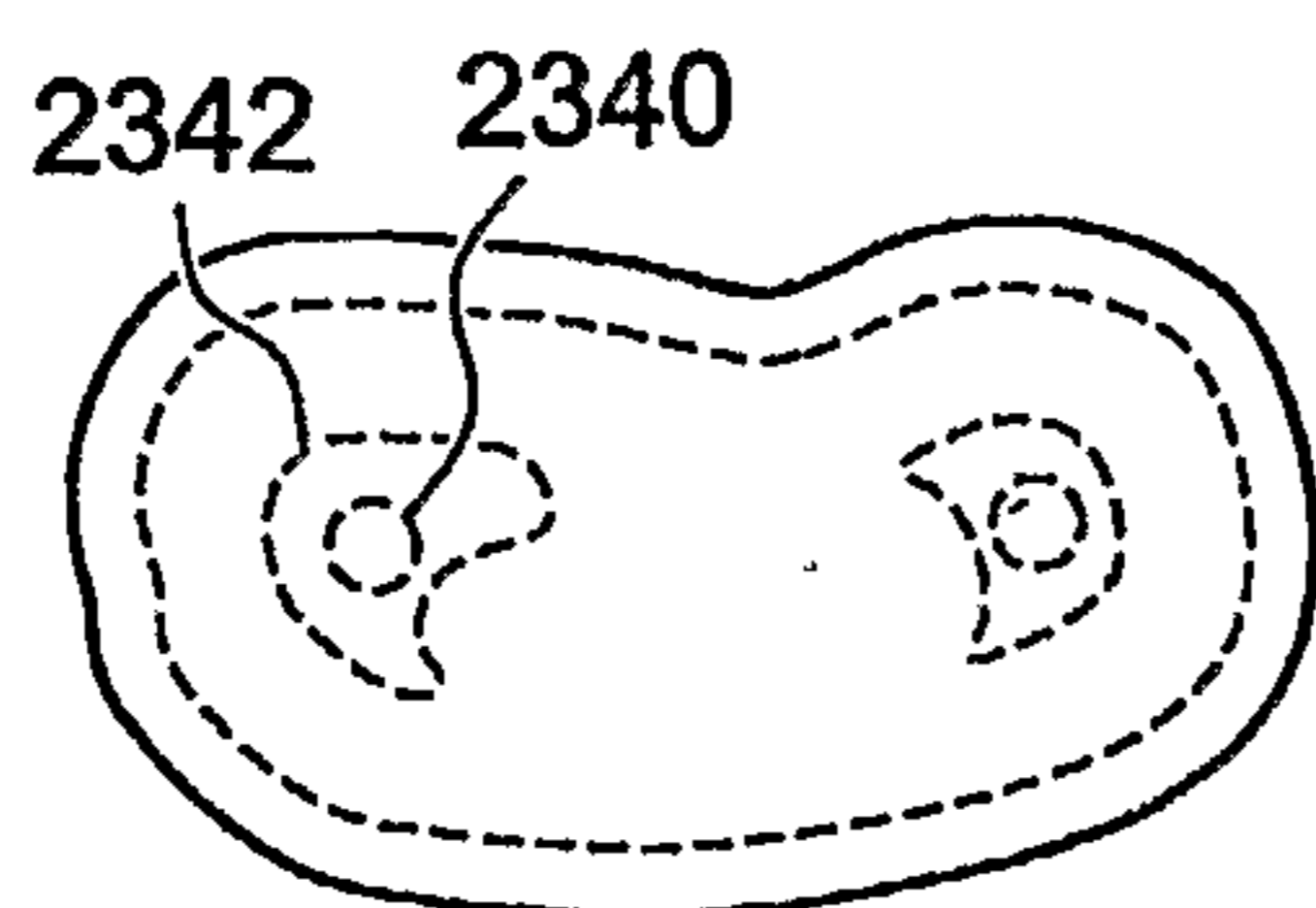

FIG. 25K

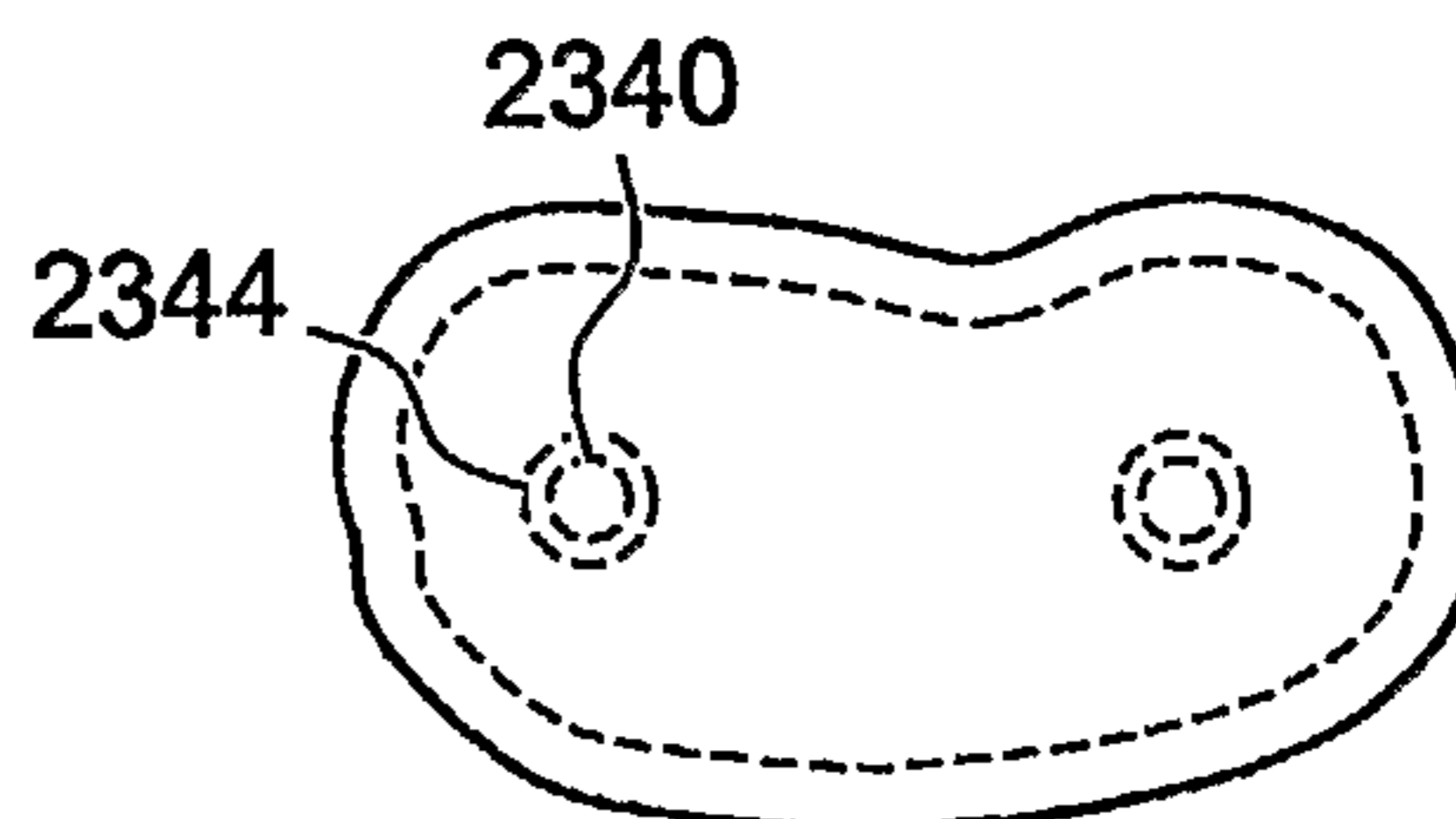

FIG. 25L

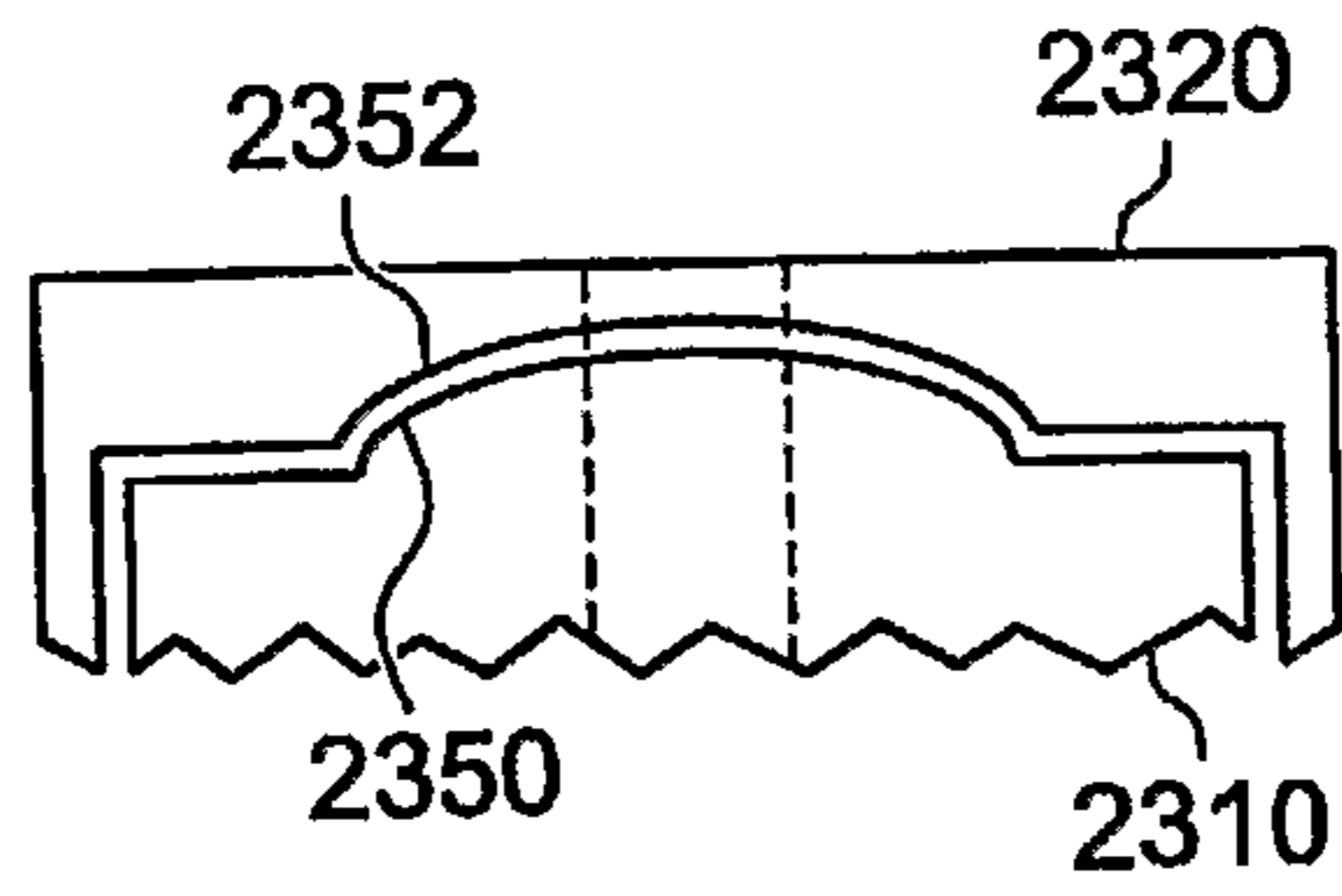

FIG. 25M

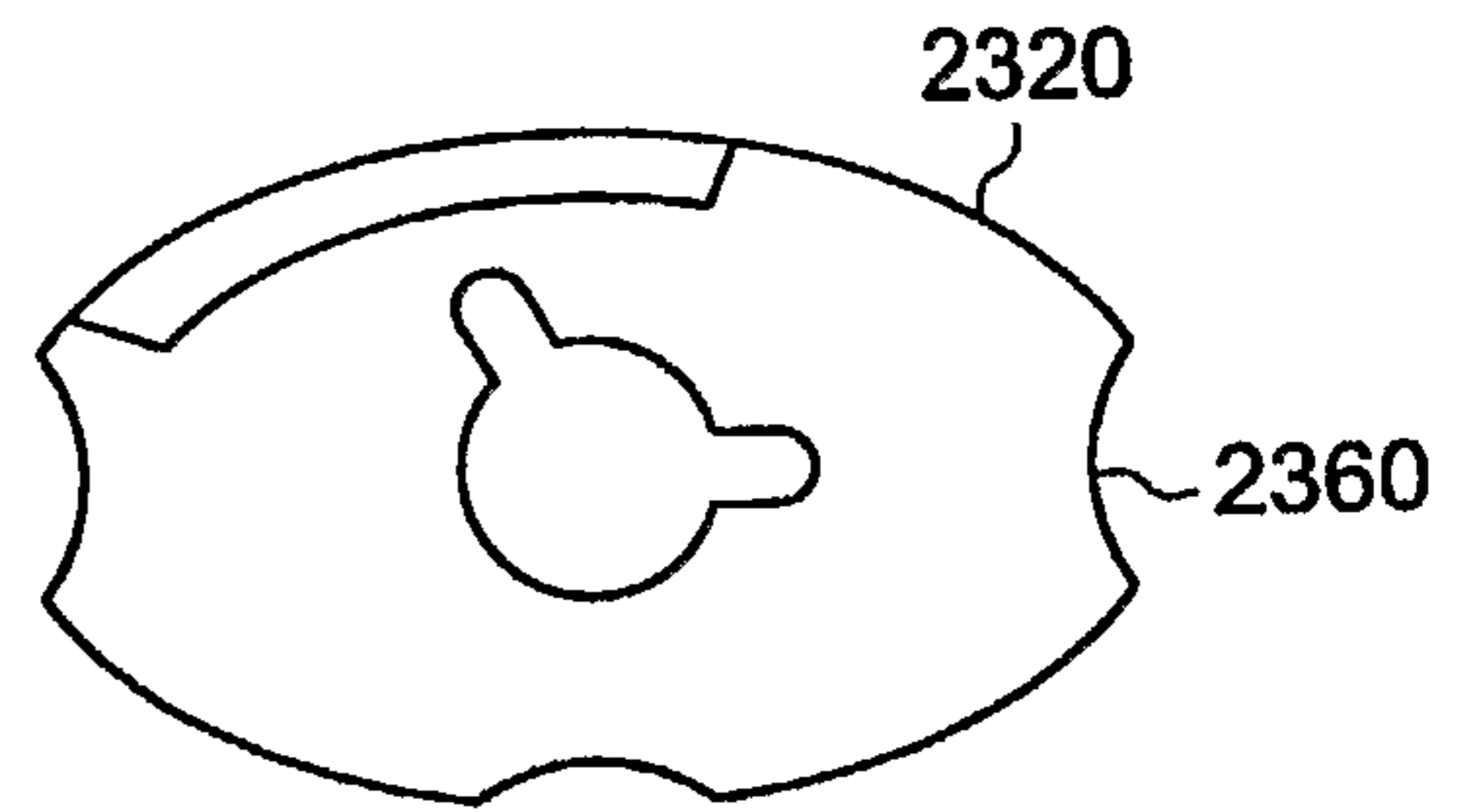

FIG. 25N

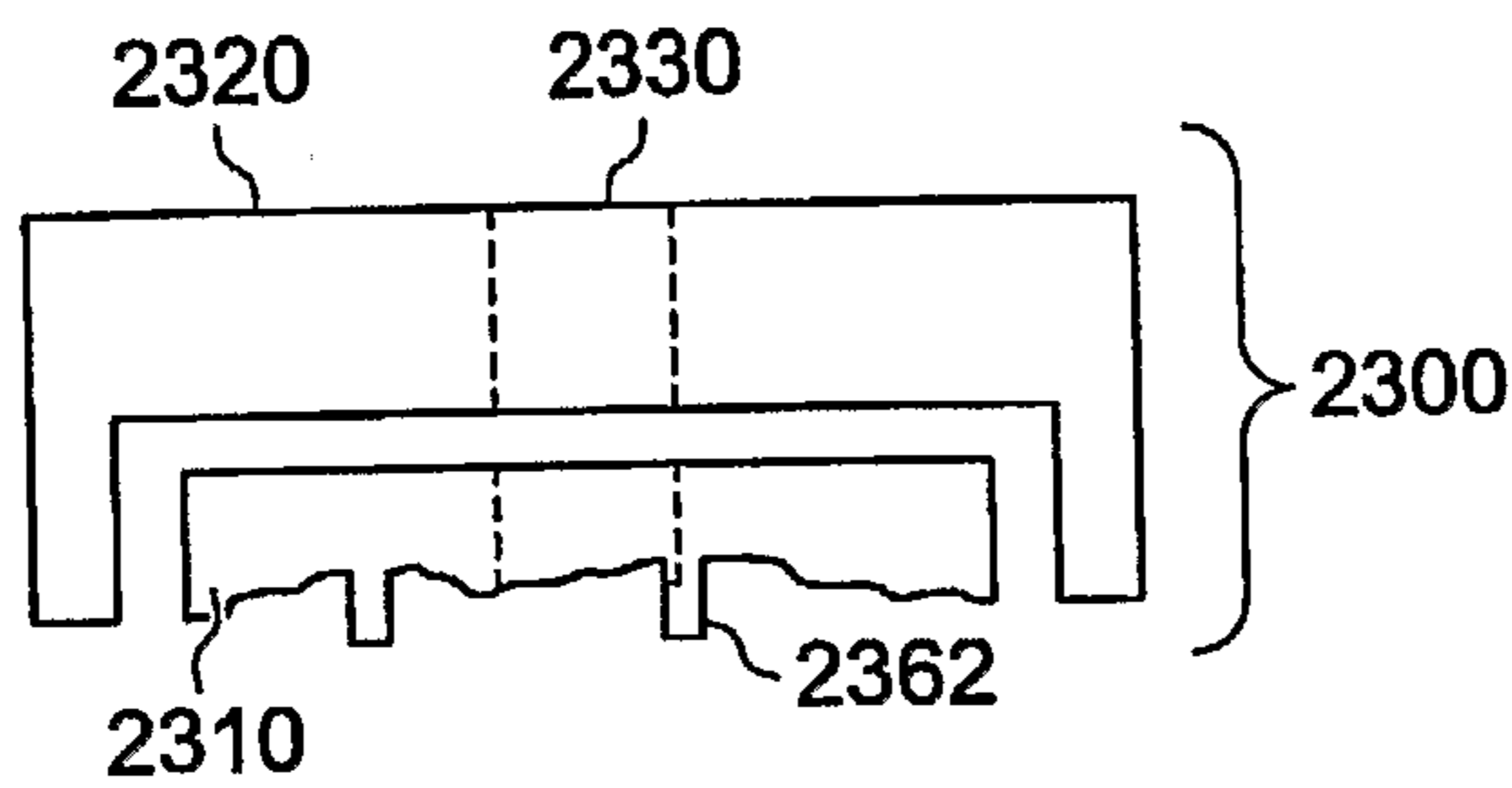

FIG. 25O

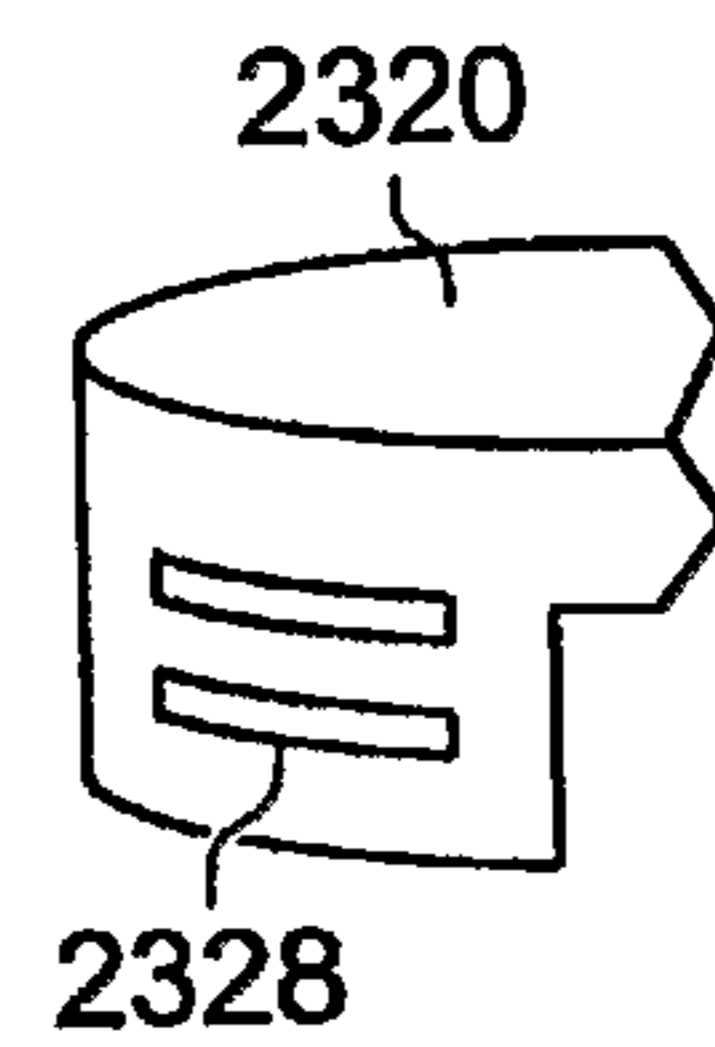

FIG. 25P

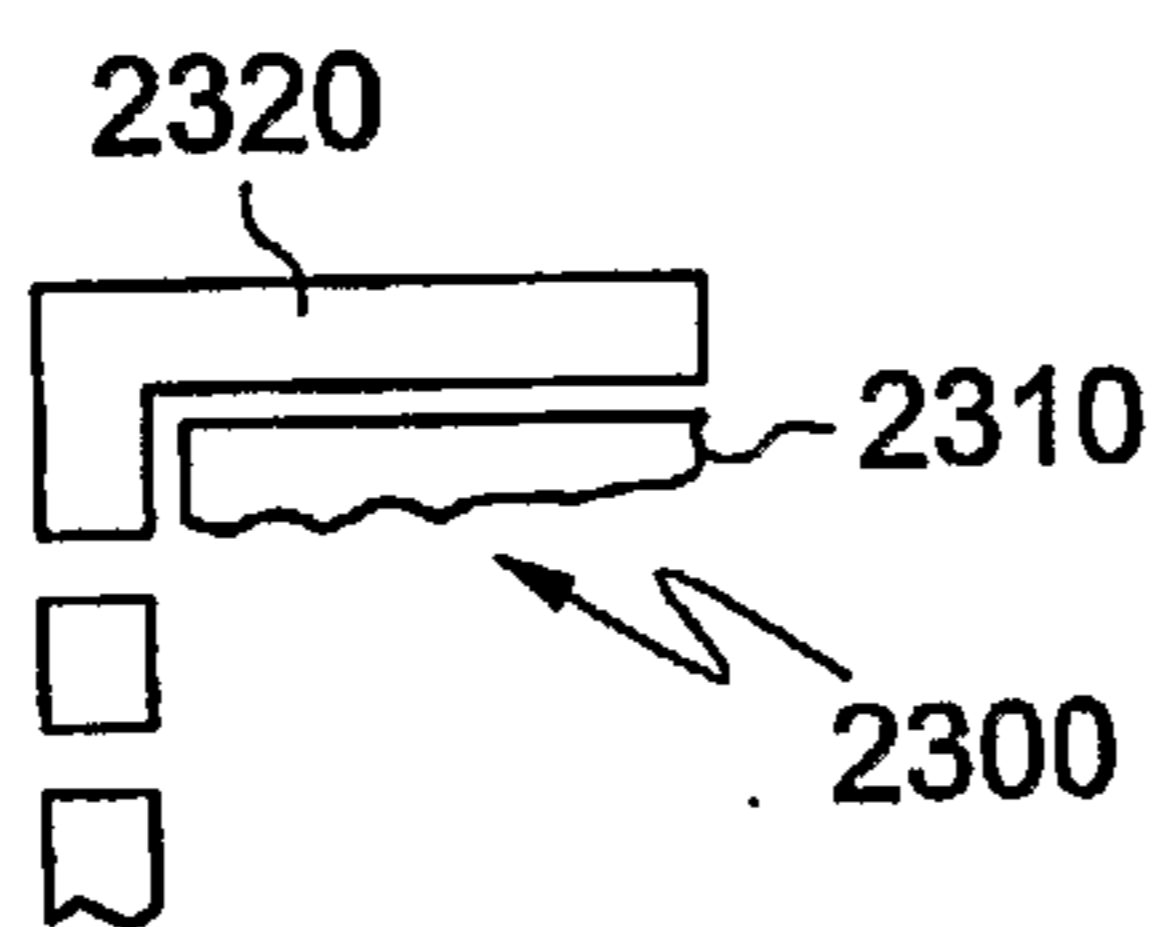

FIG. 25Q

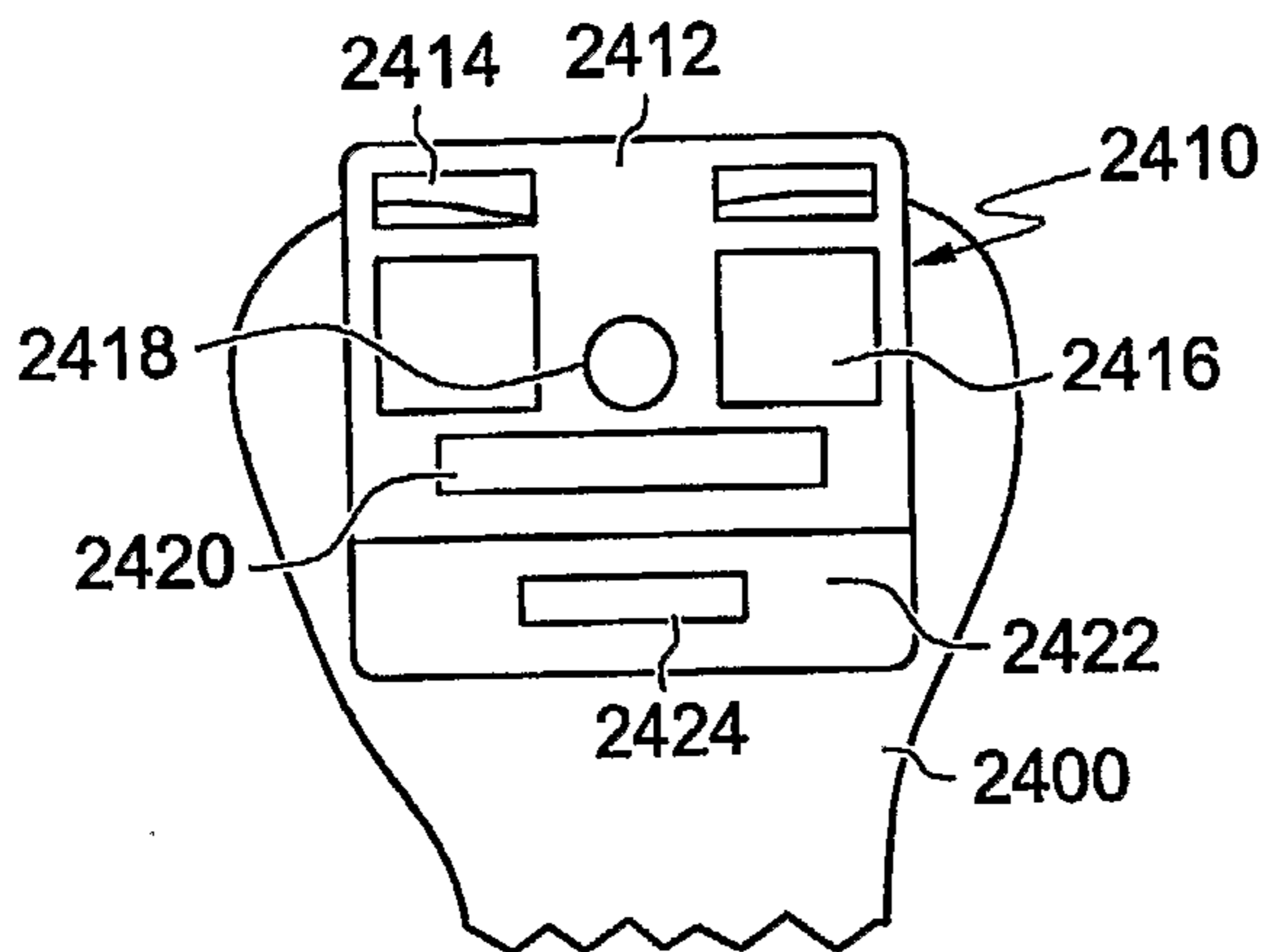

FIG. 26A

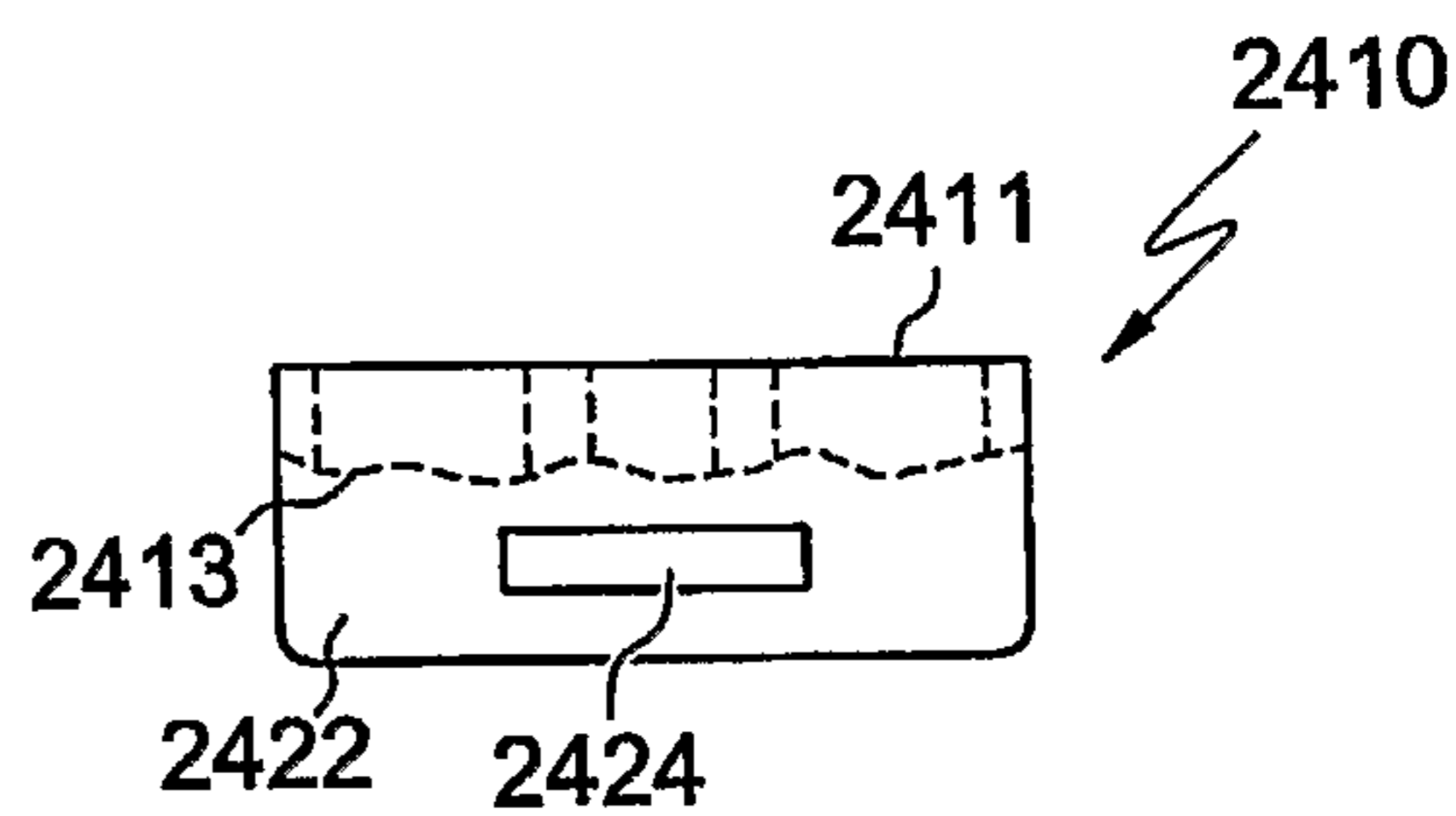

FIG. 26B

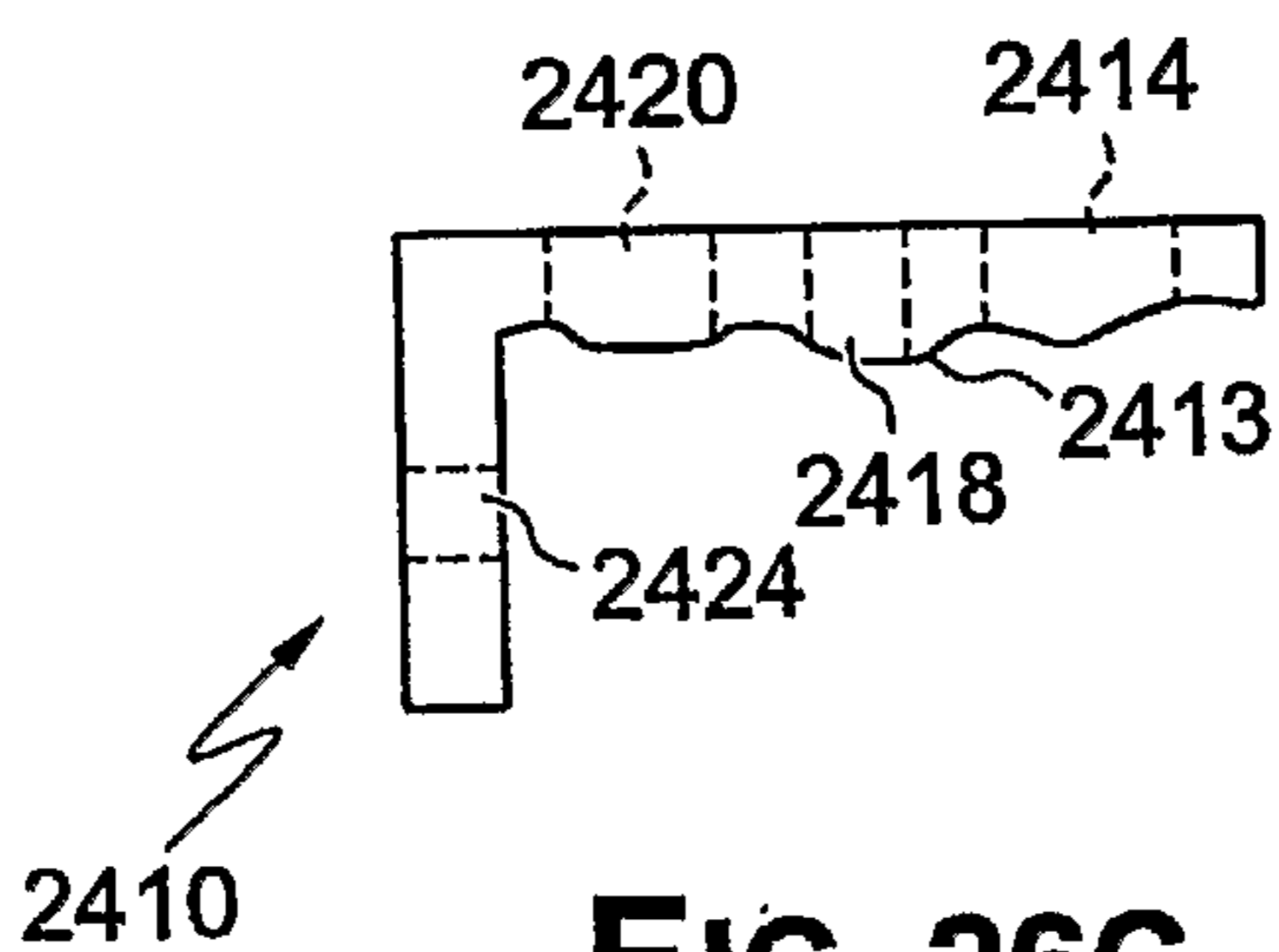

FIG. 26C

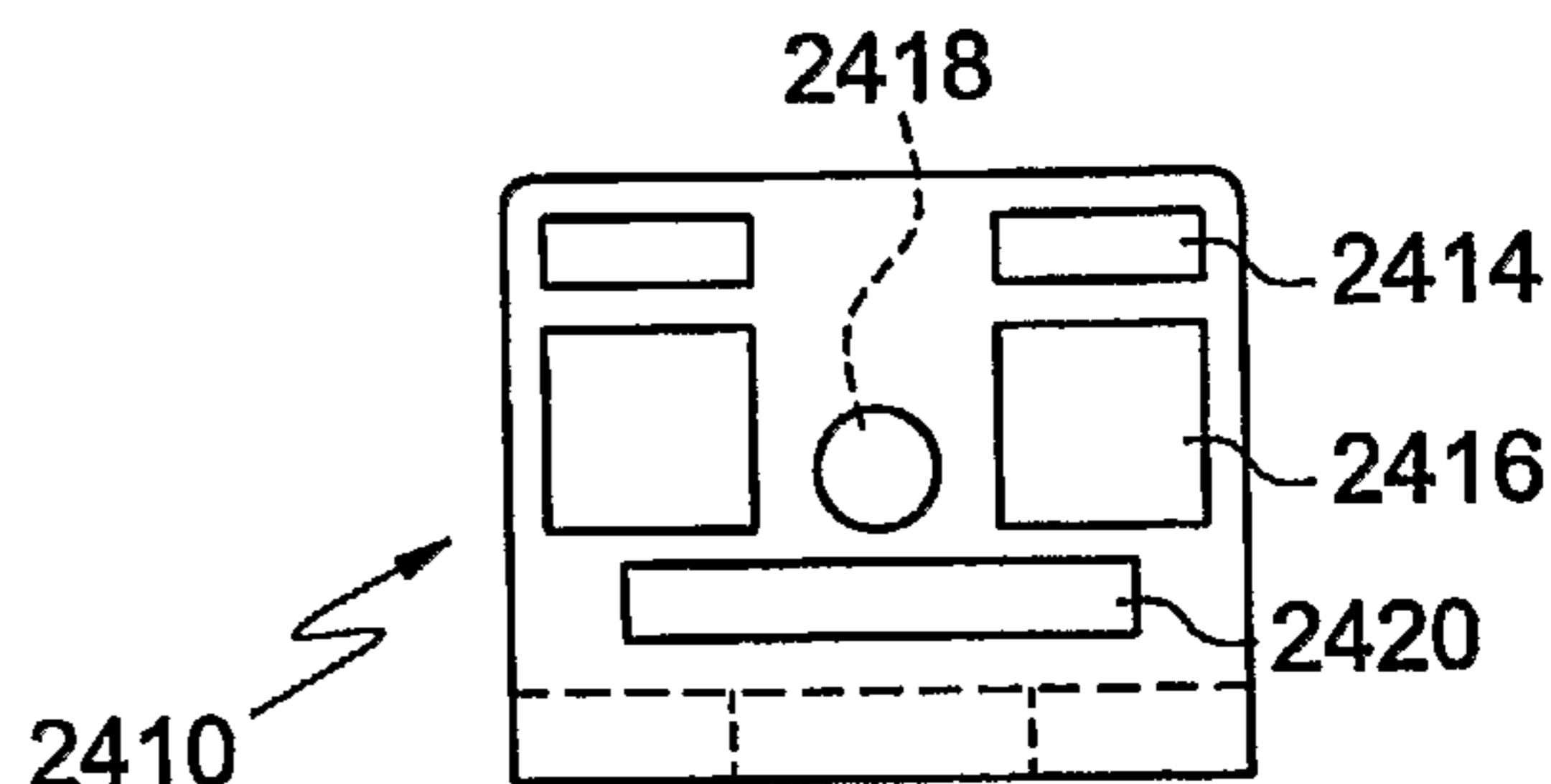

FIG. 26D

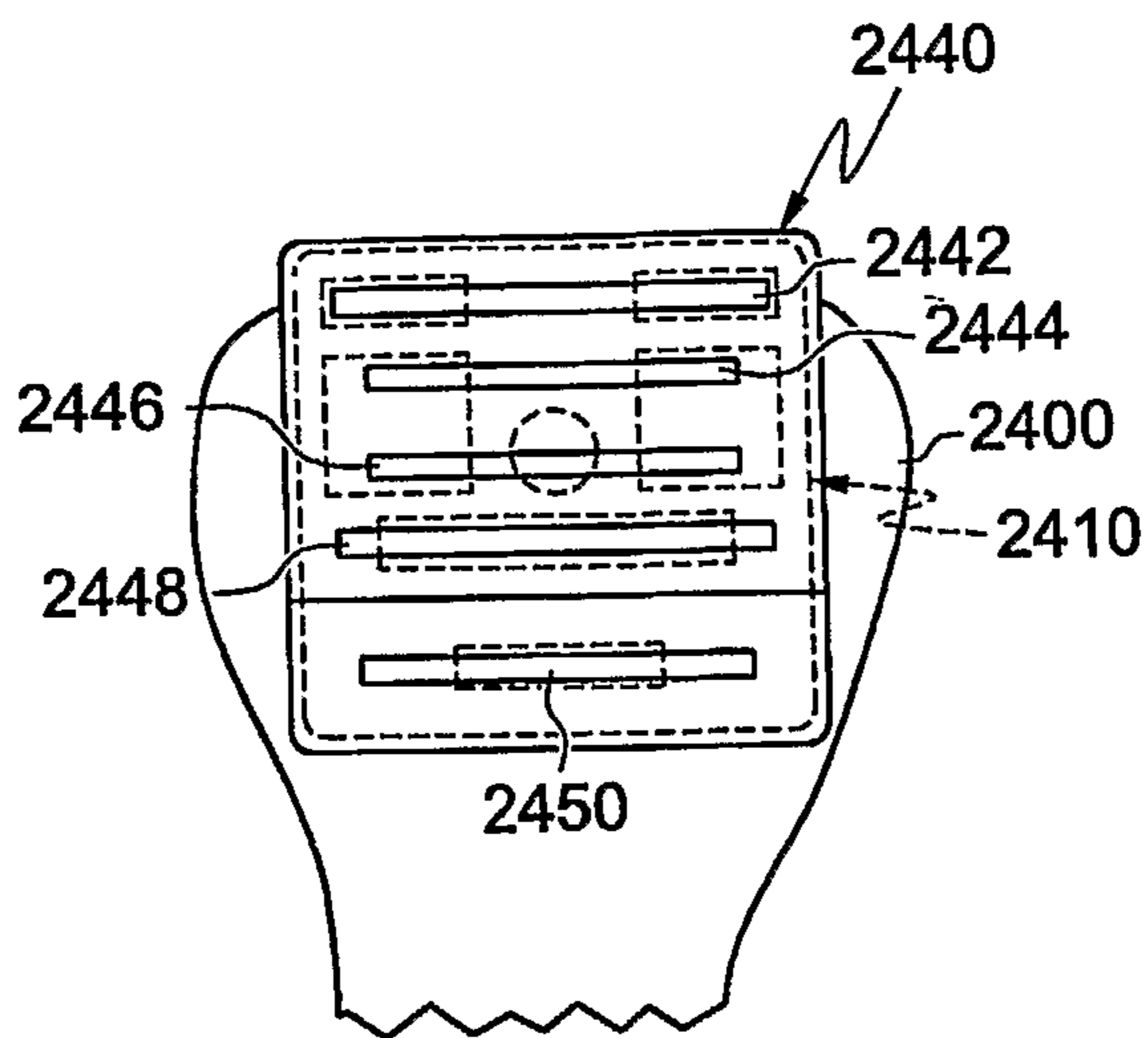

FIG. 26E

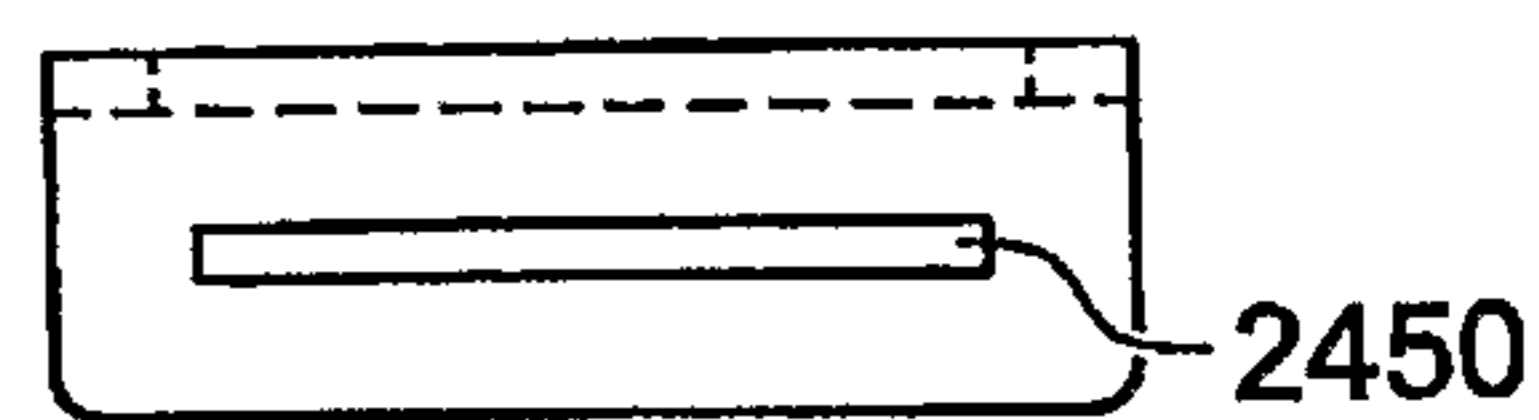

FIG. 26F

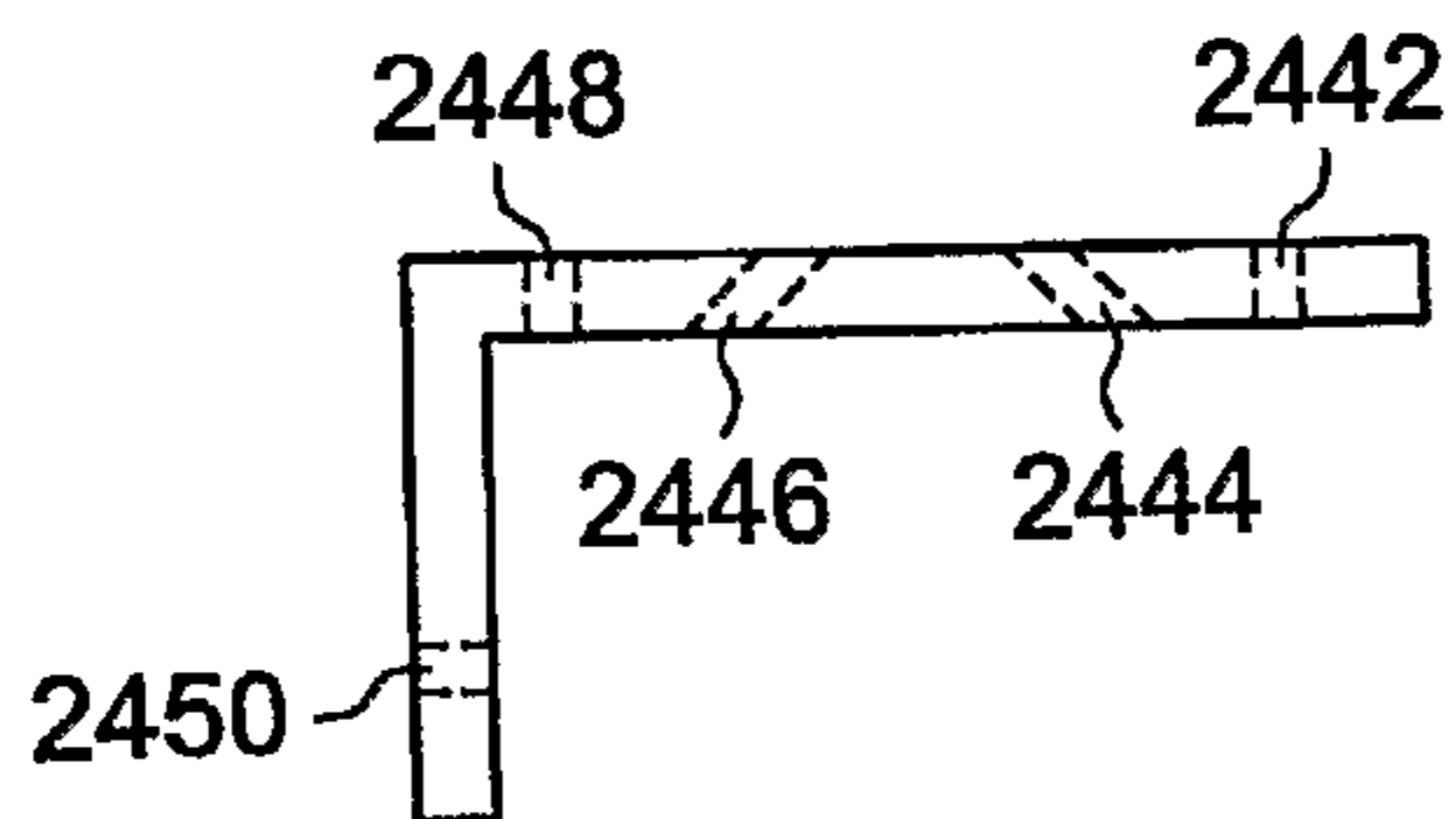

FIG. 26G

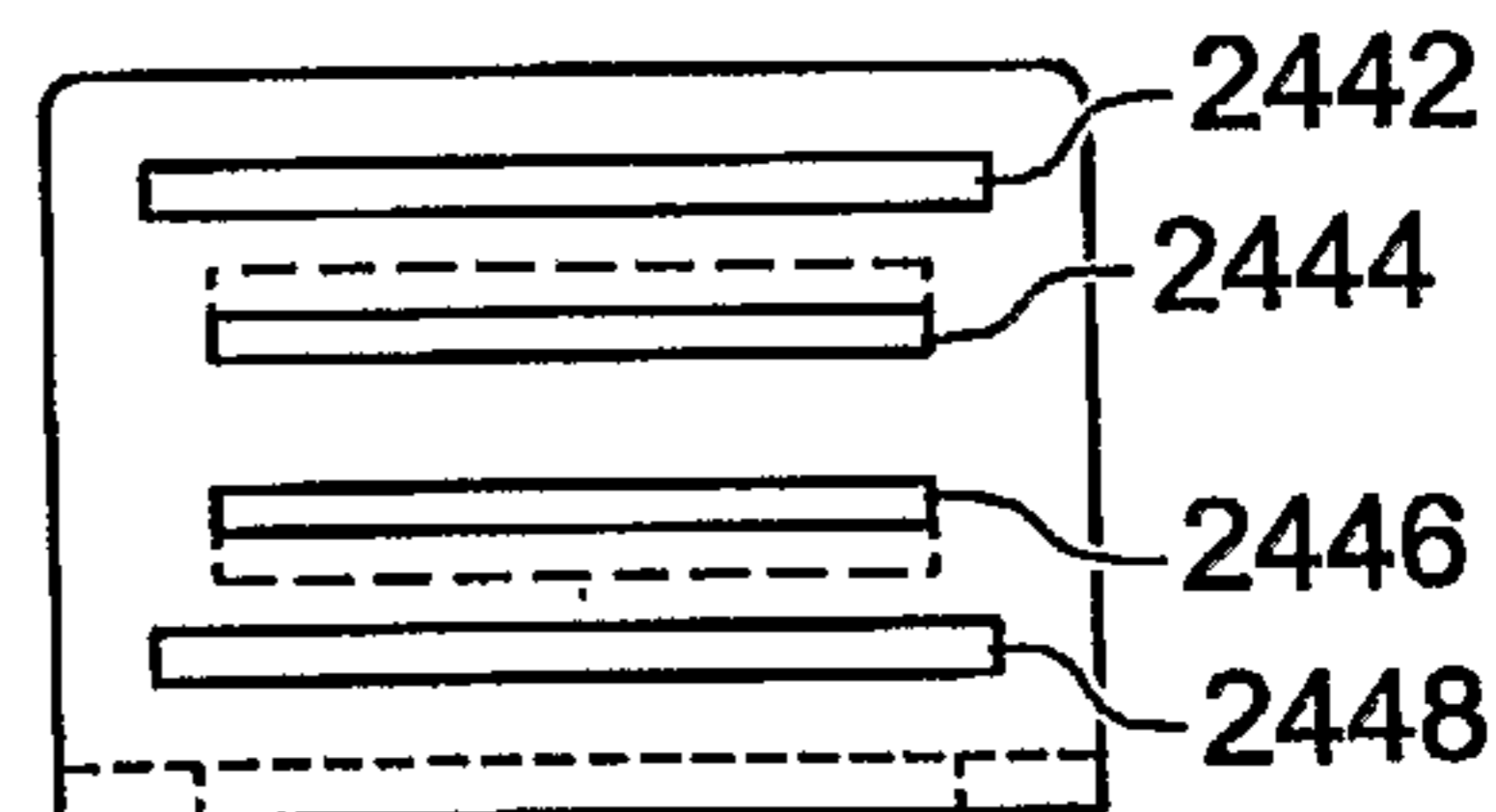

FIG. 26H

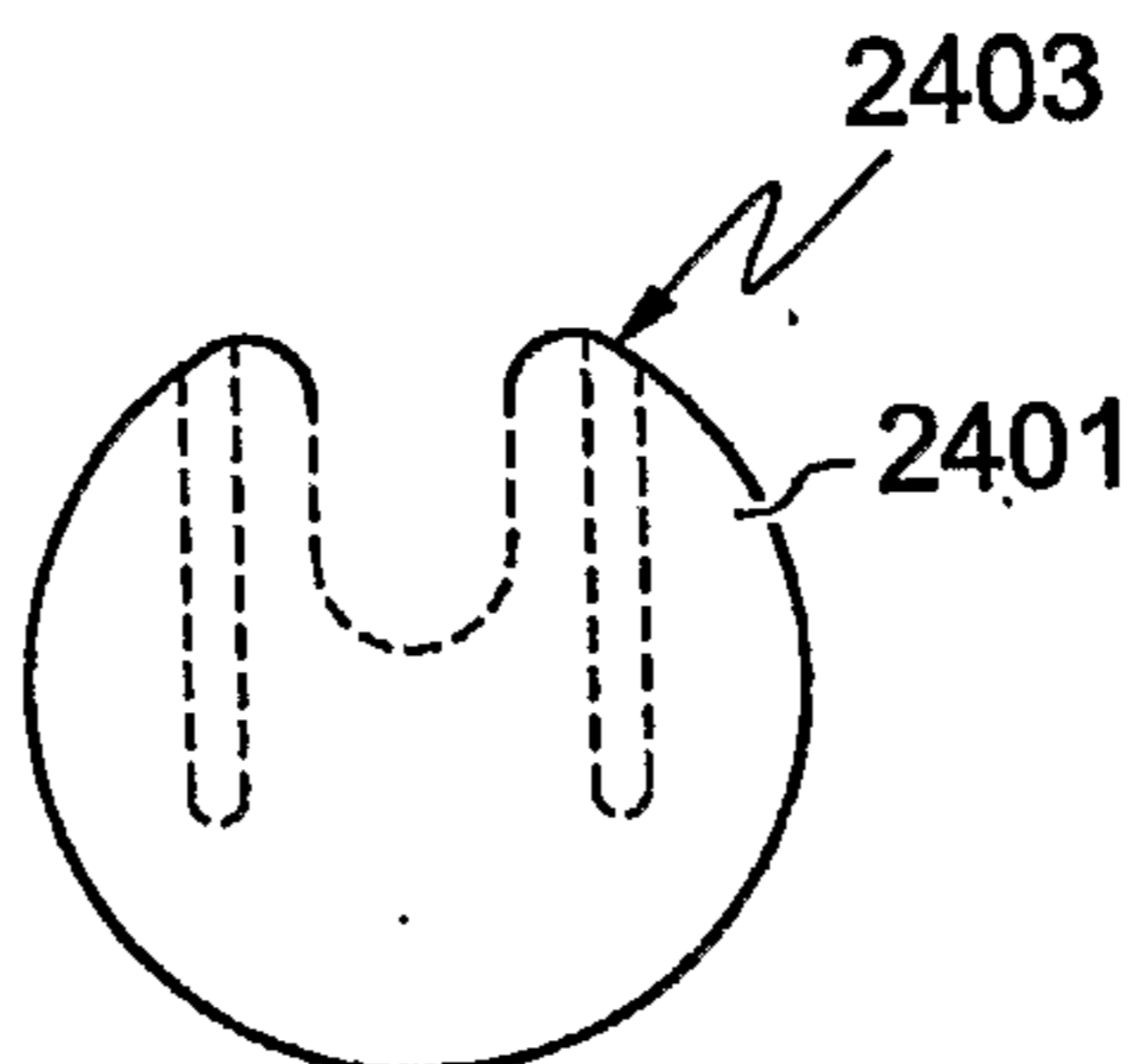

FIG. 26I

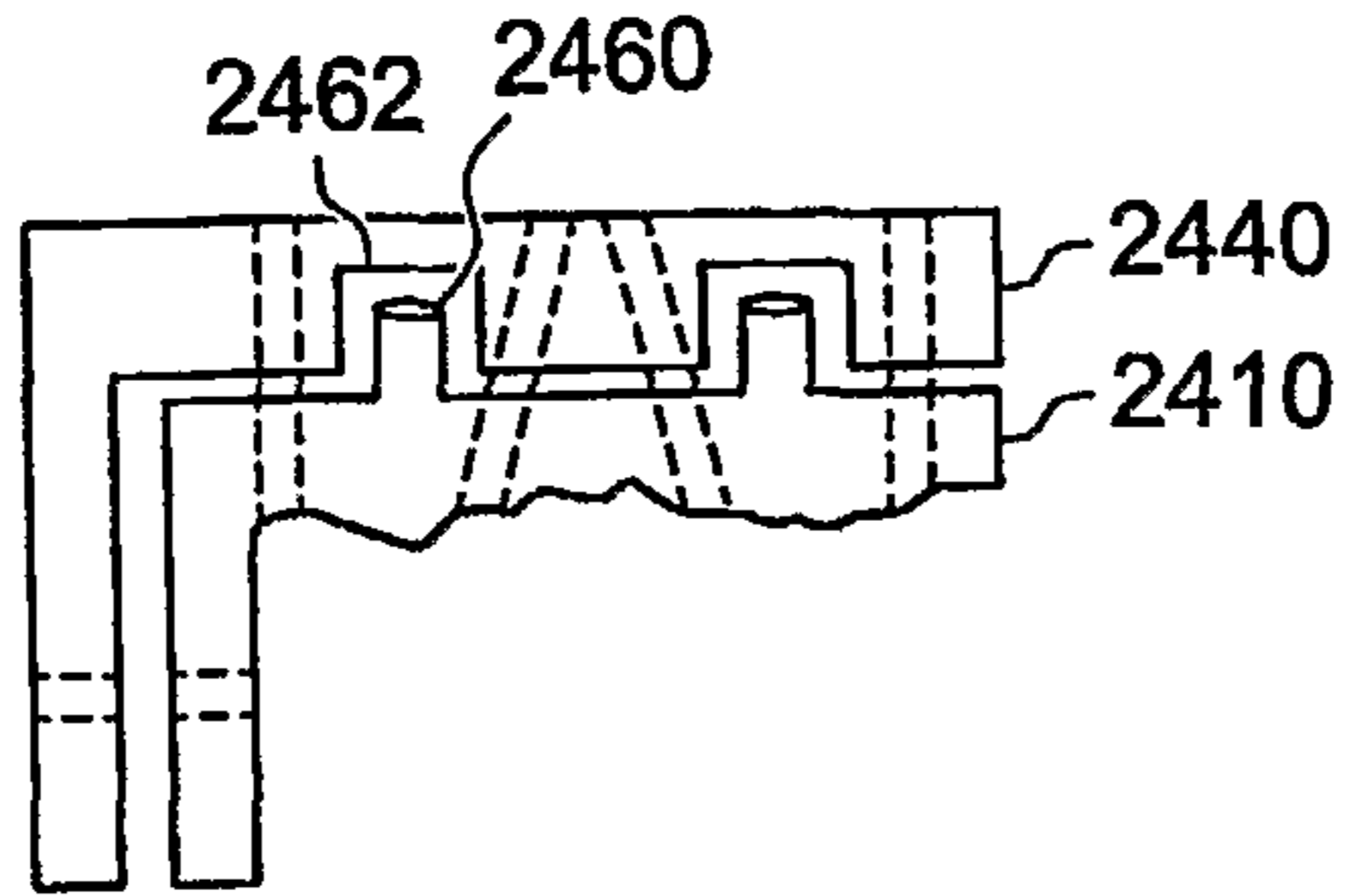

FIG. 26J

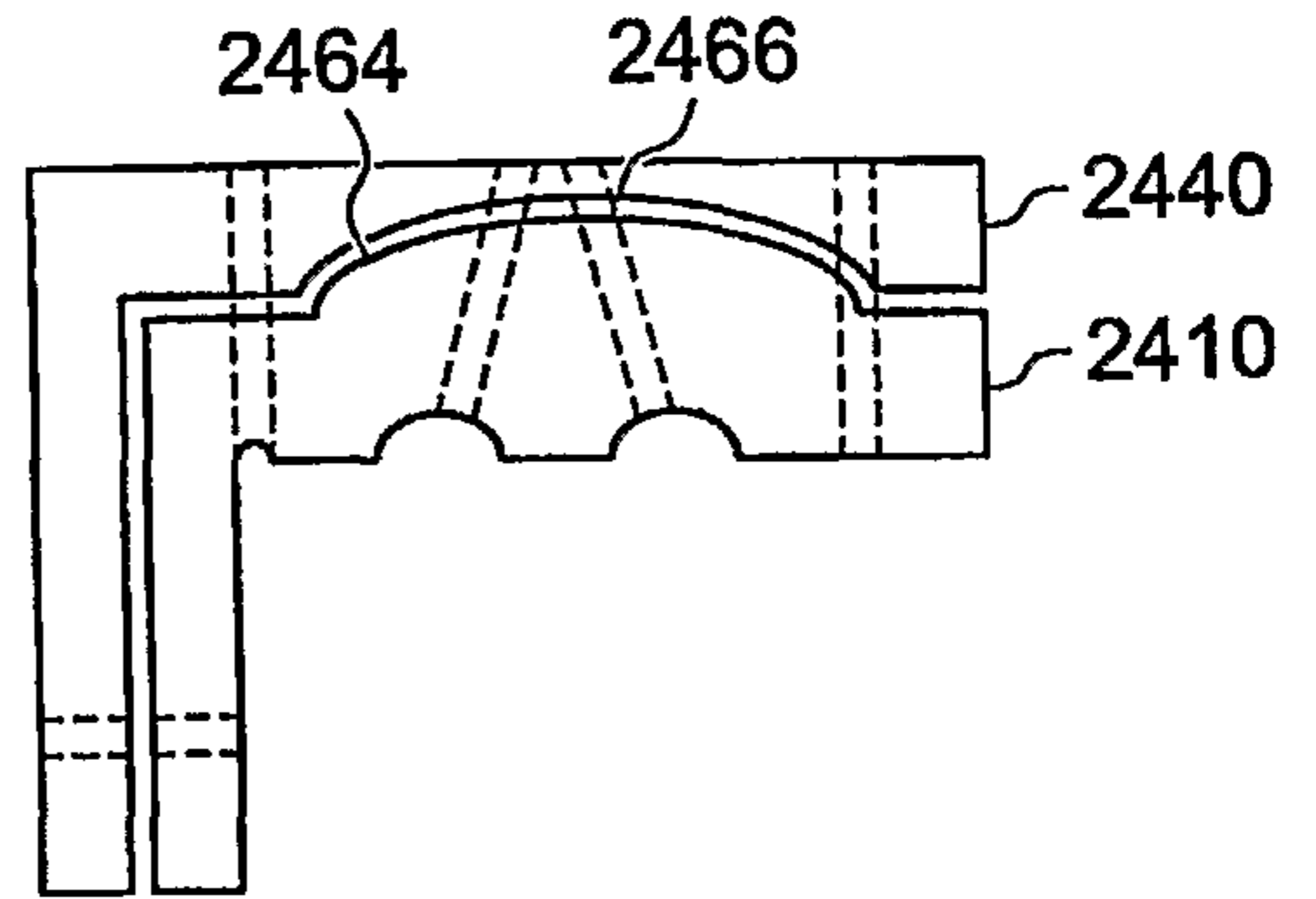

FIG. 26K

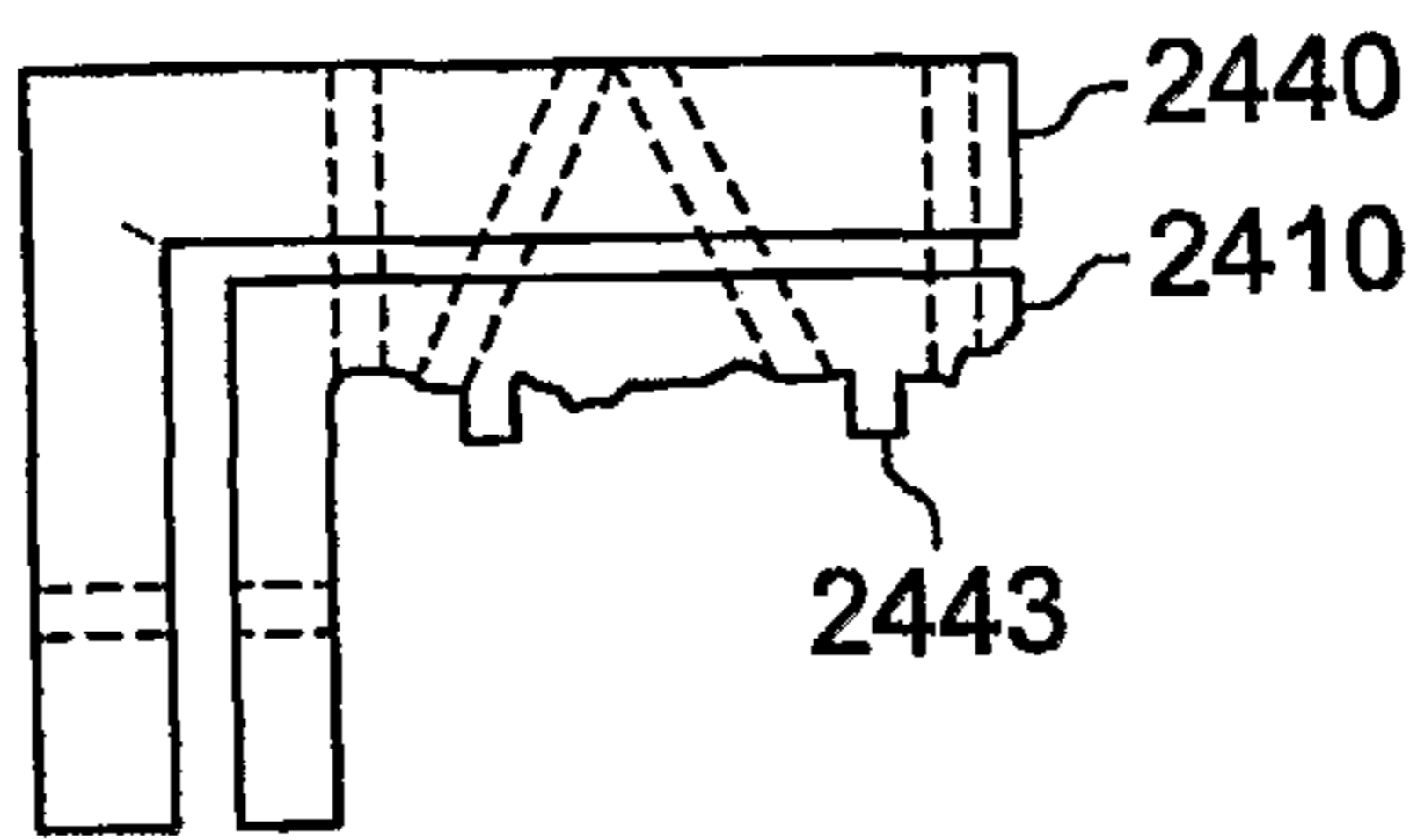

FIG. 26L

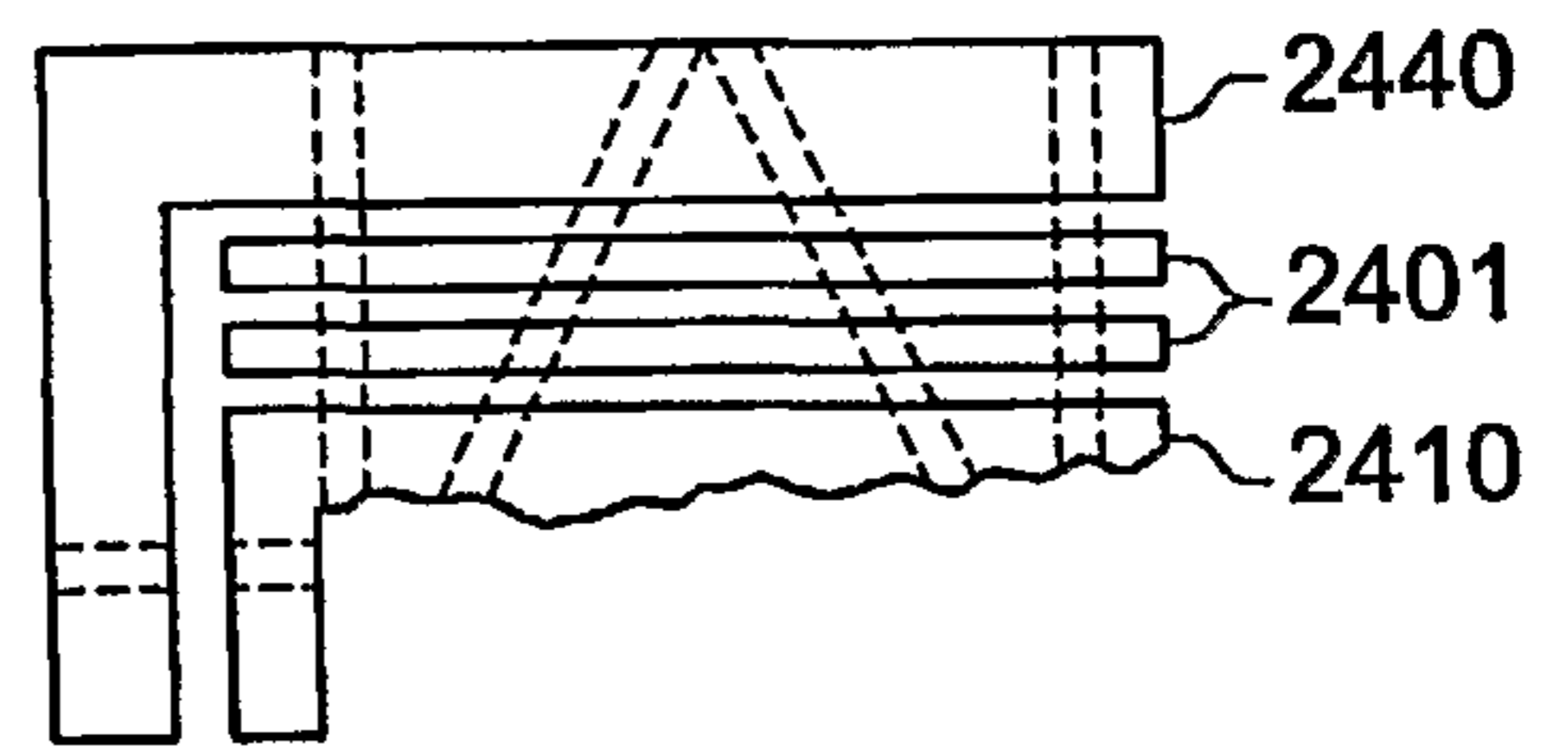

FIG. 26M

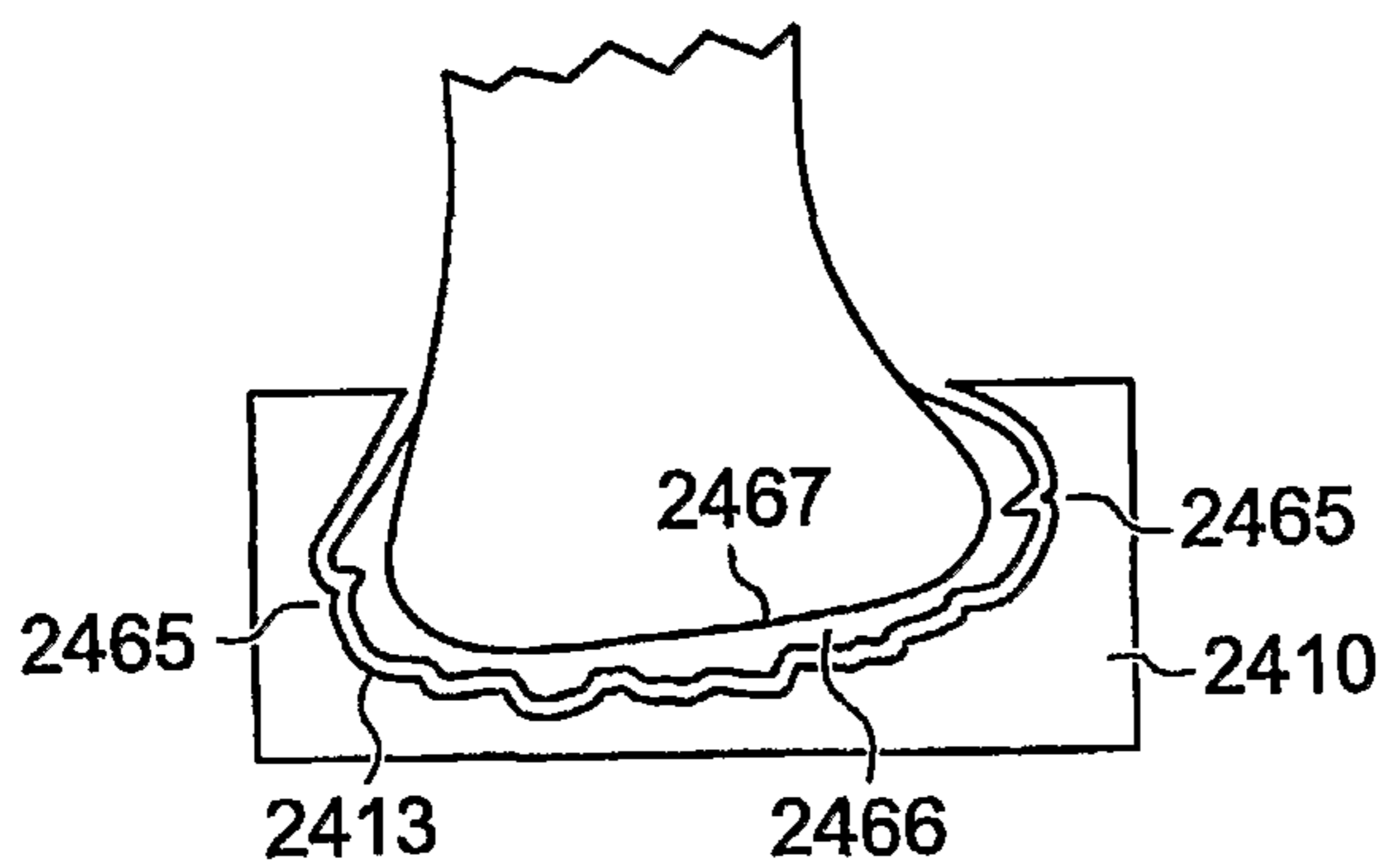

FIG. 26N

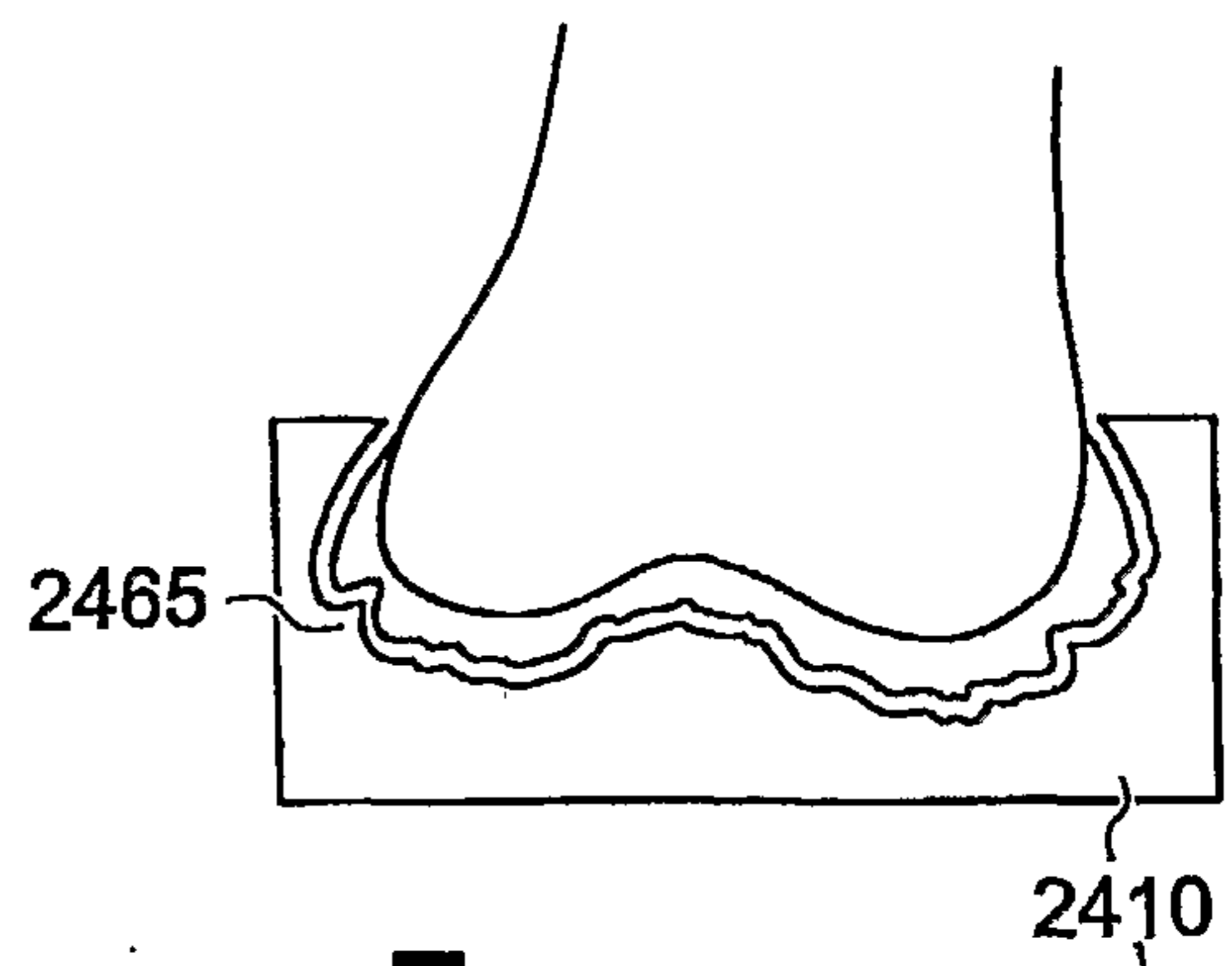

FIG. 26O

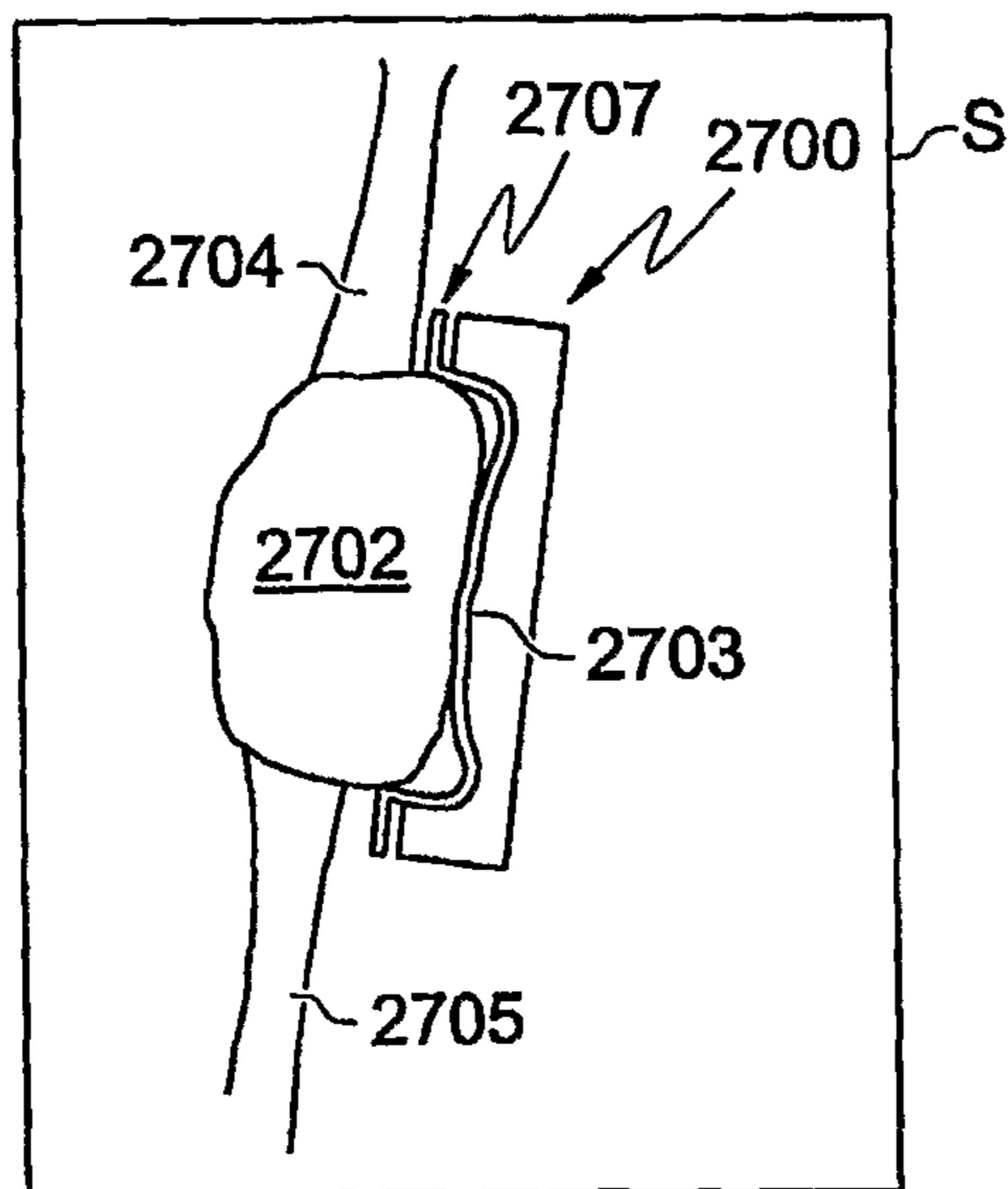

FIG. 27A

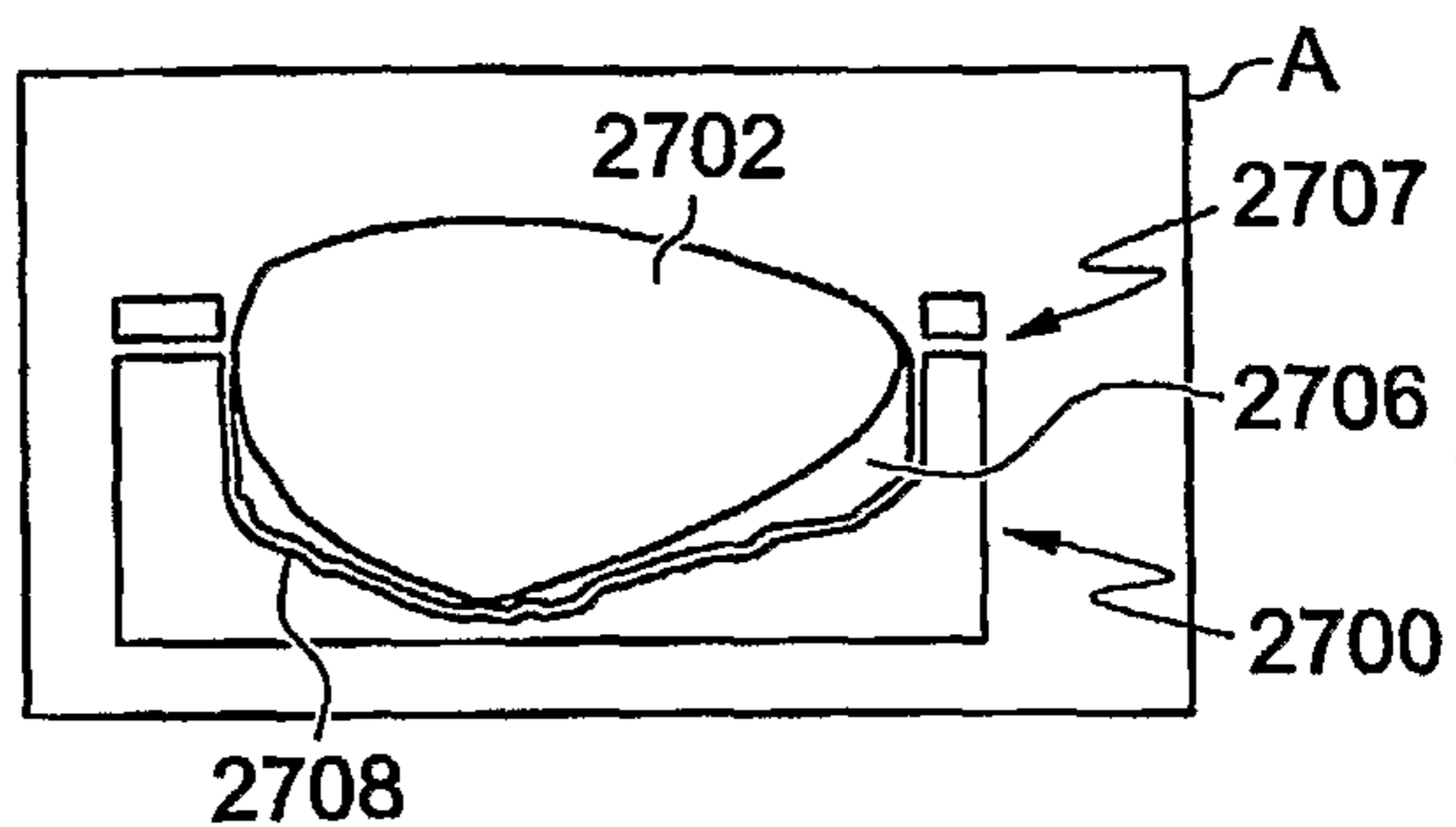

FIG. 27B

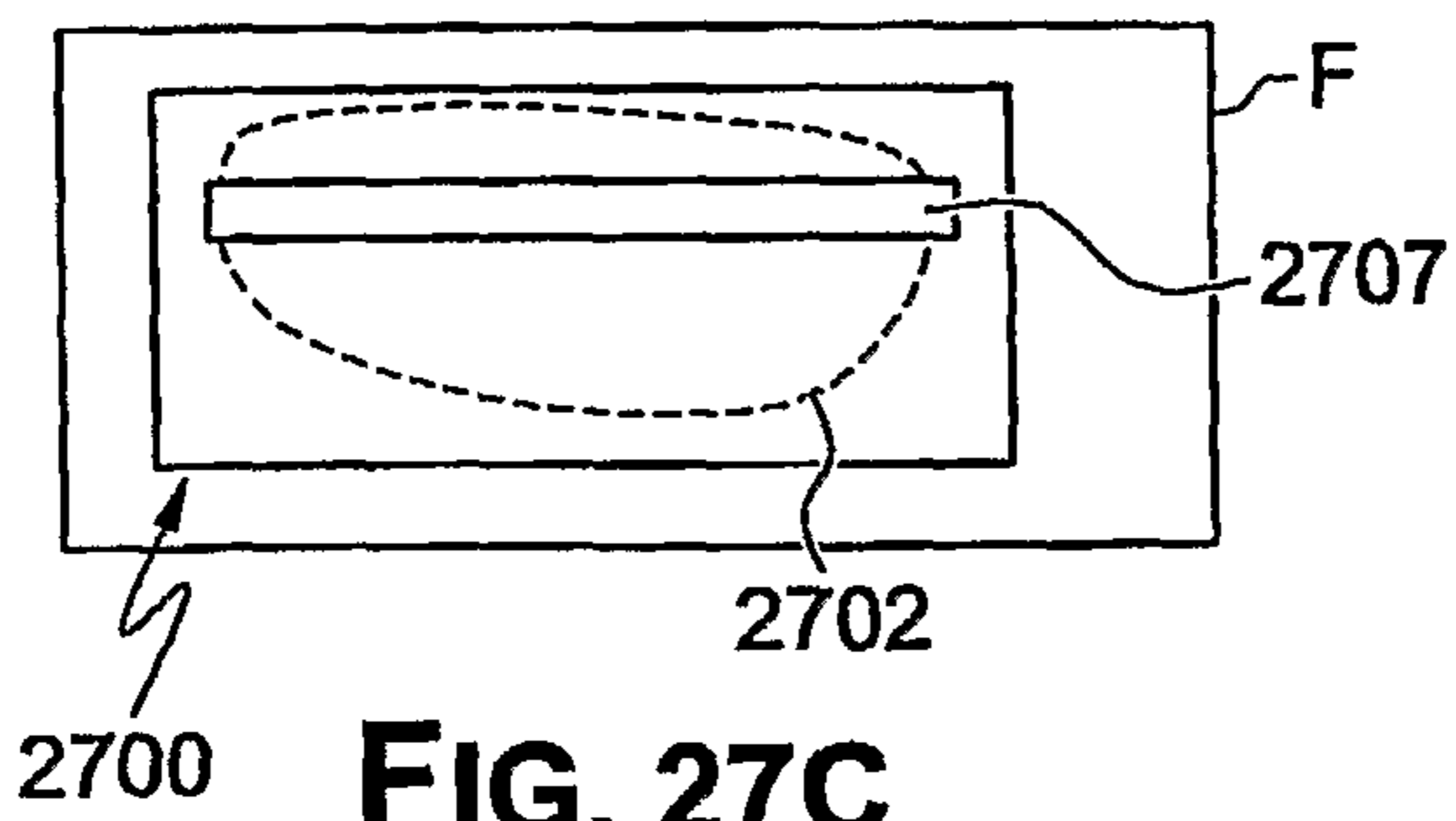

FIG. 27C

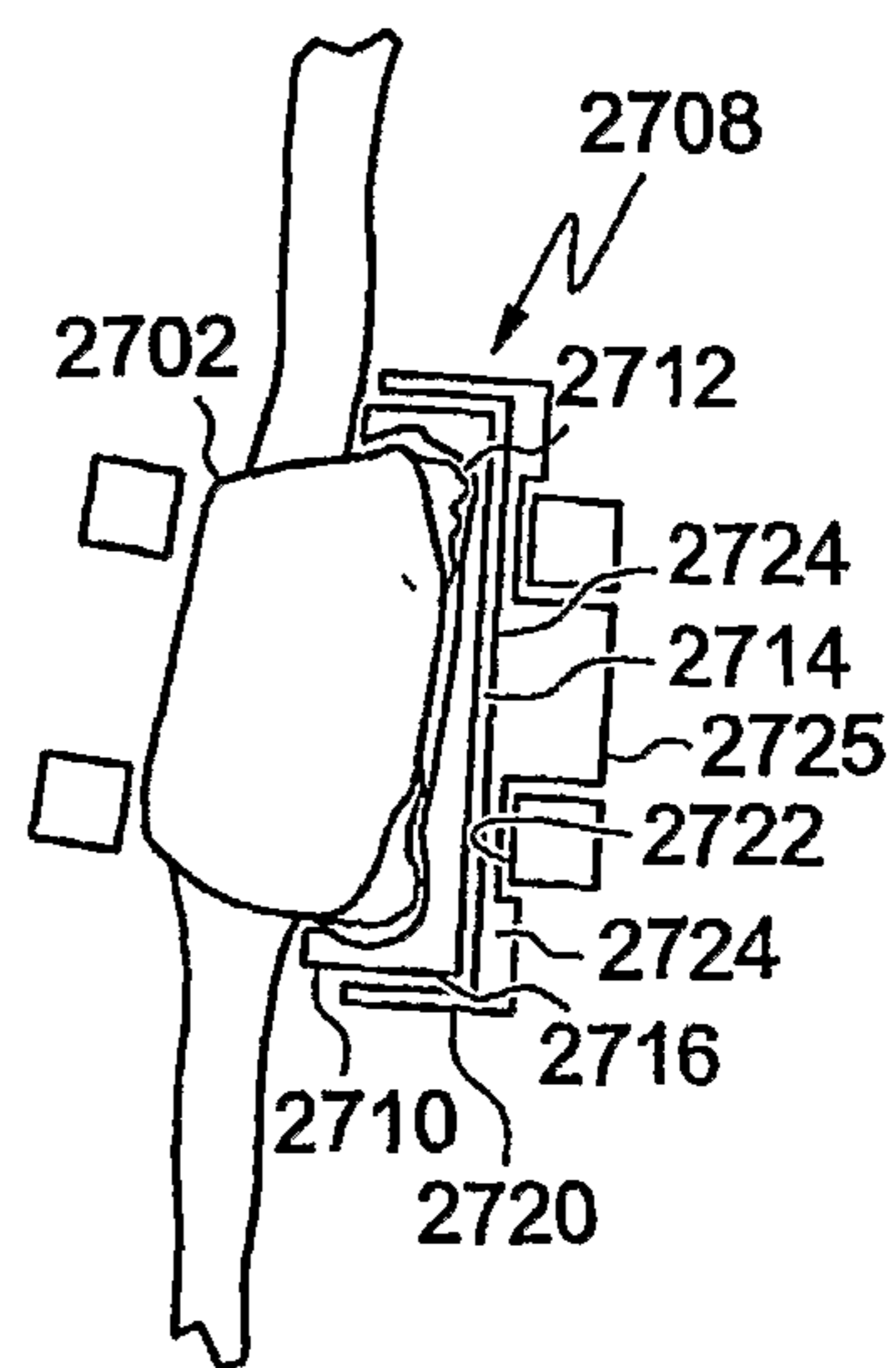

FIG. 27D

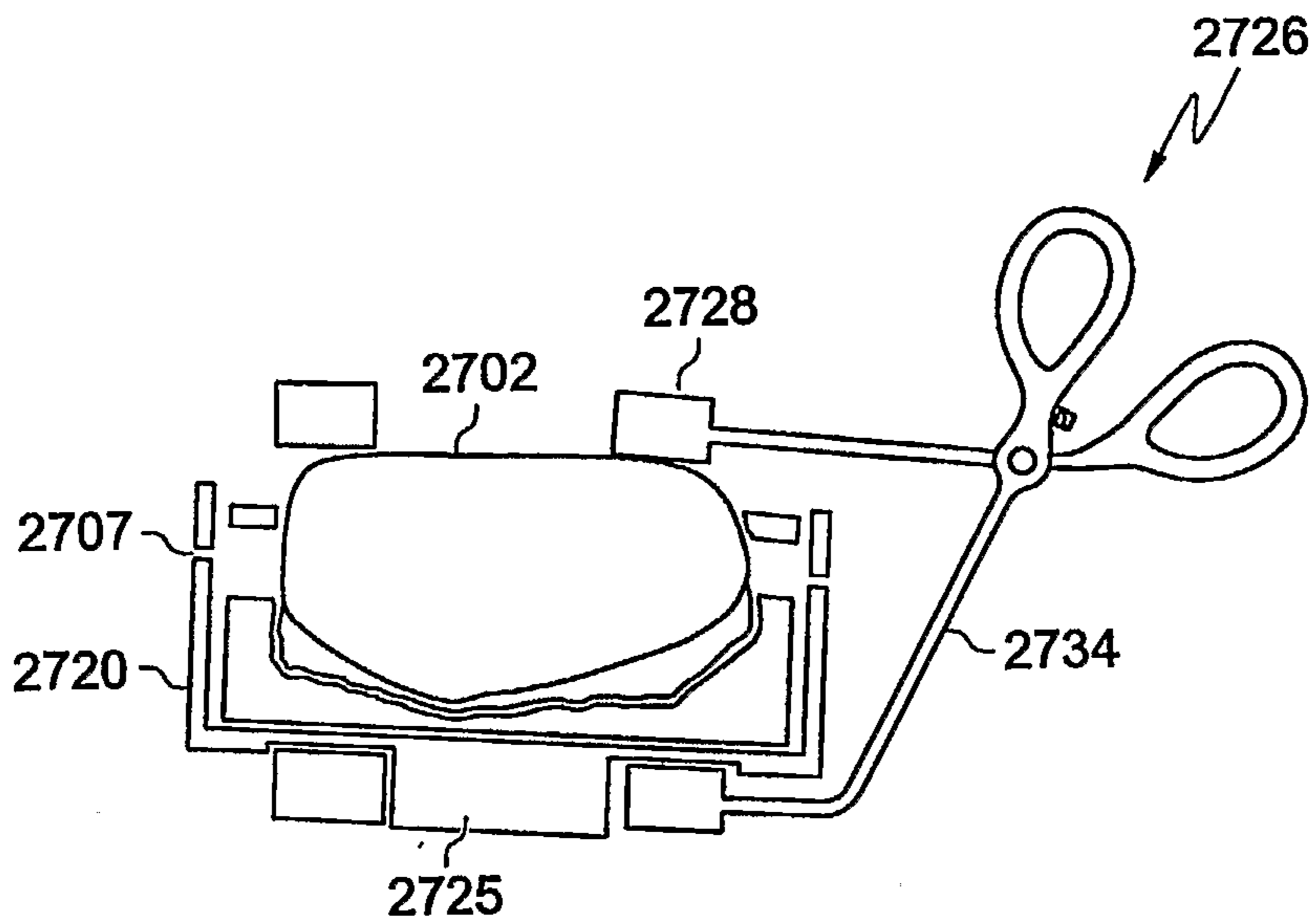

FIG. 27E

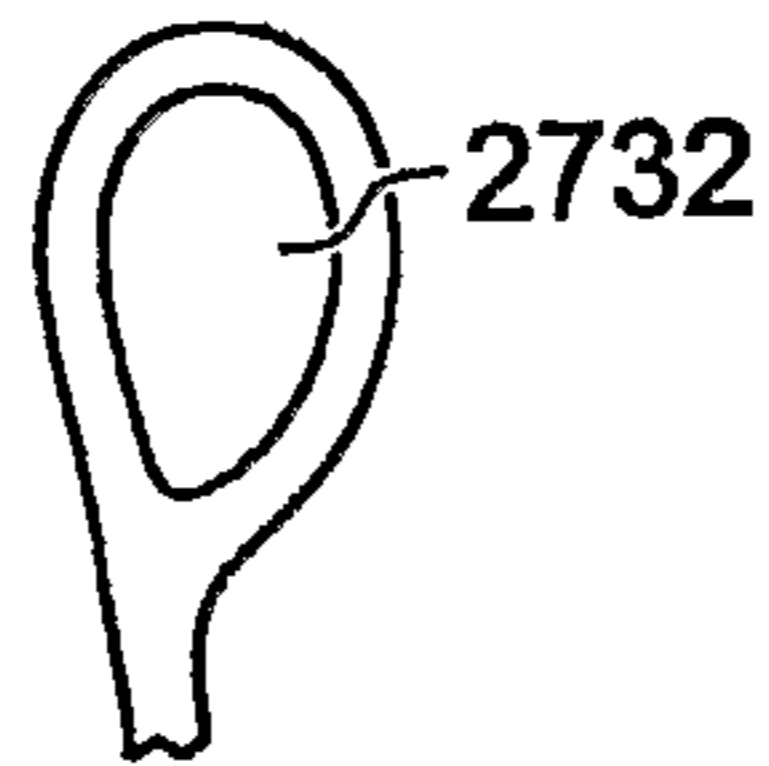

FIG. 27F

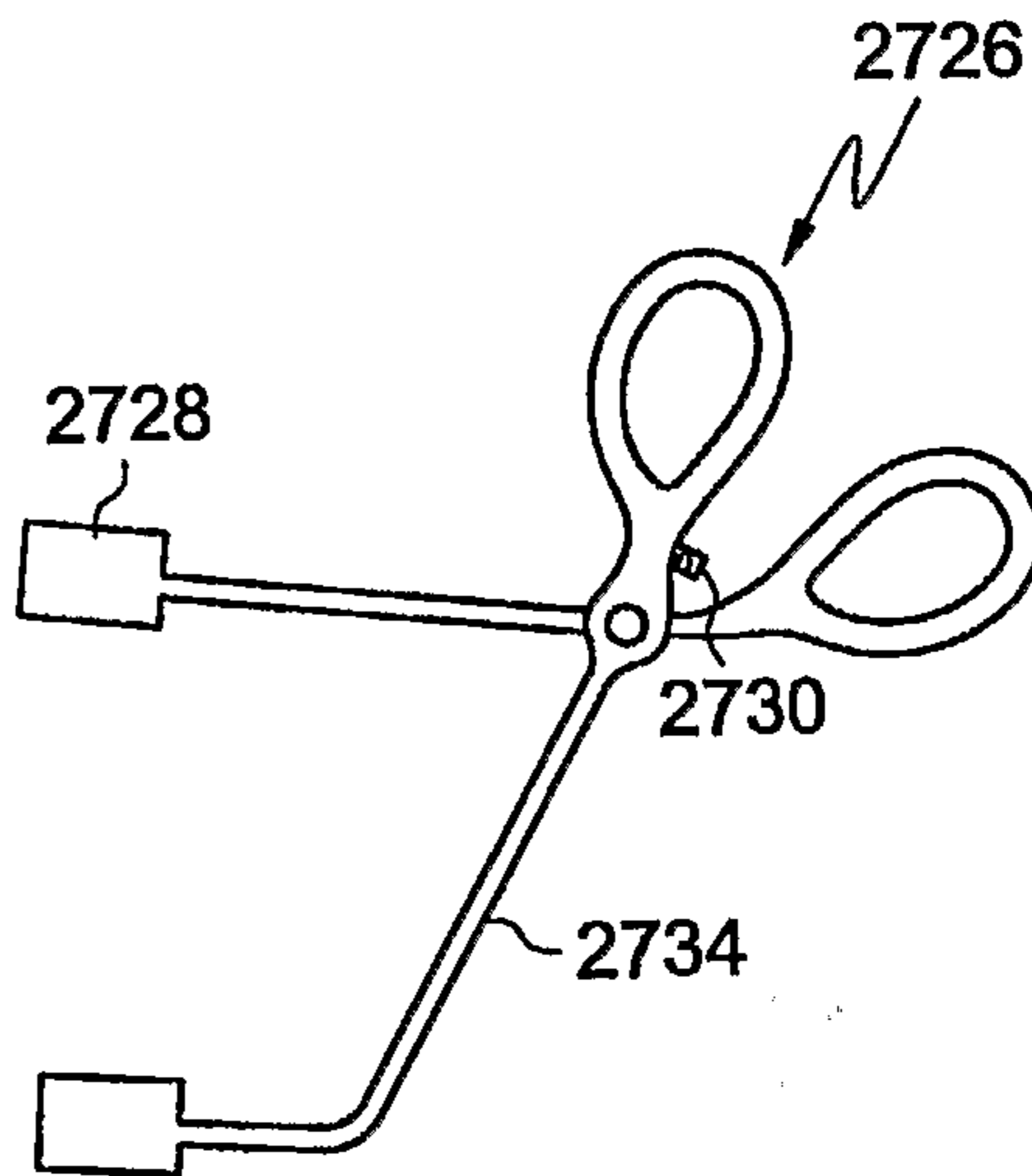

FIG. 27G

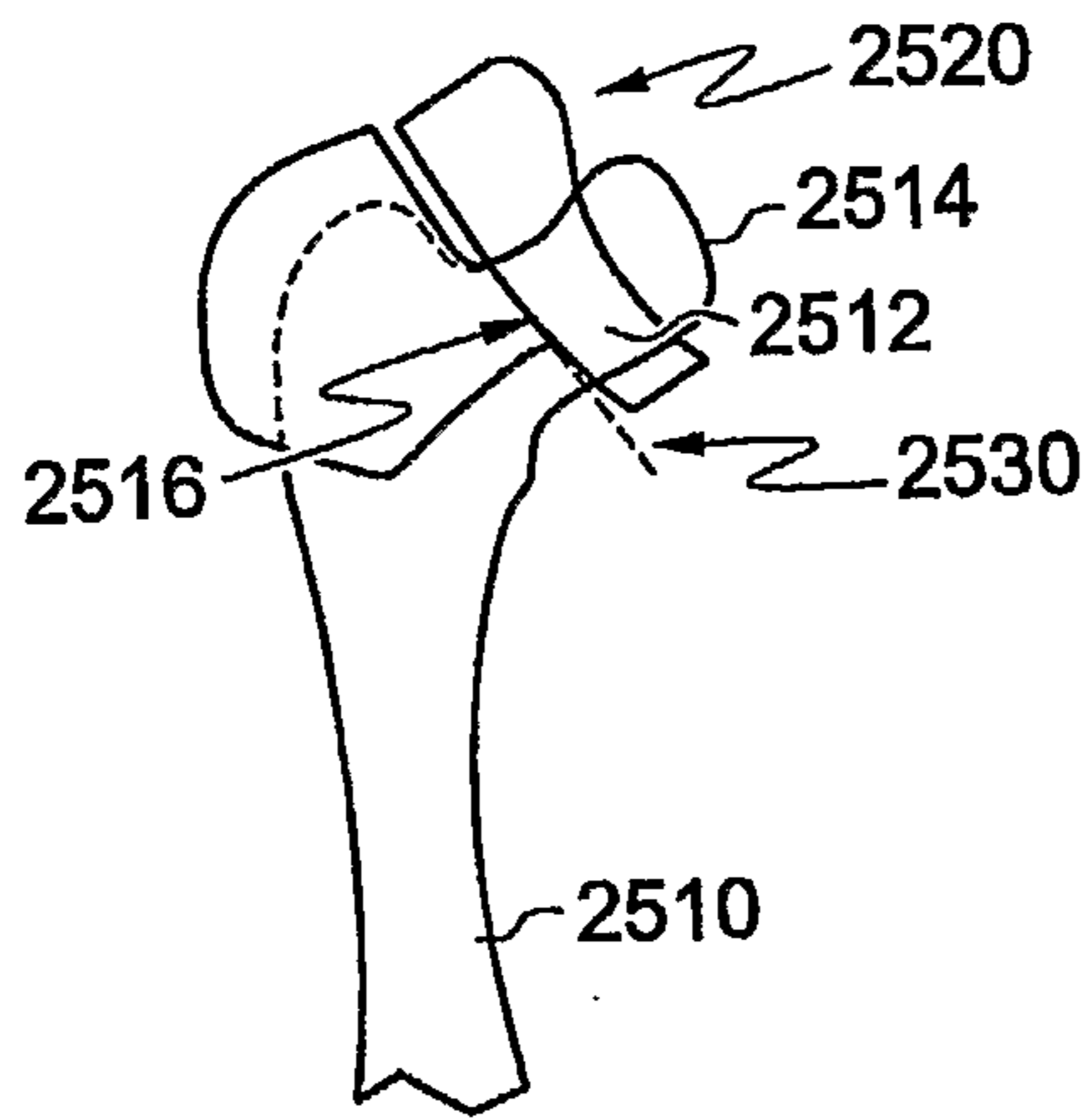

FIG. 28A

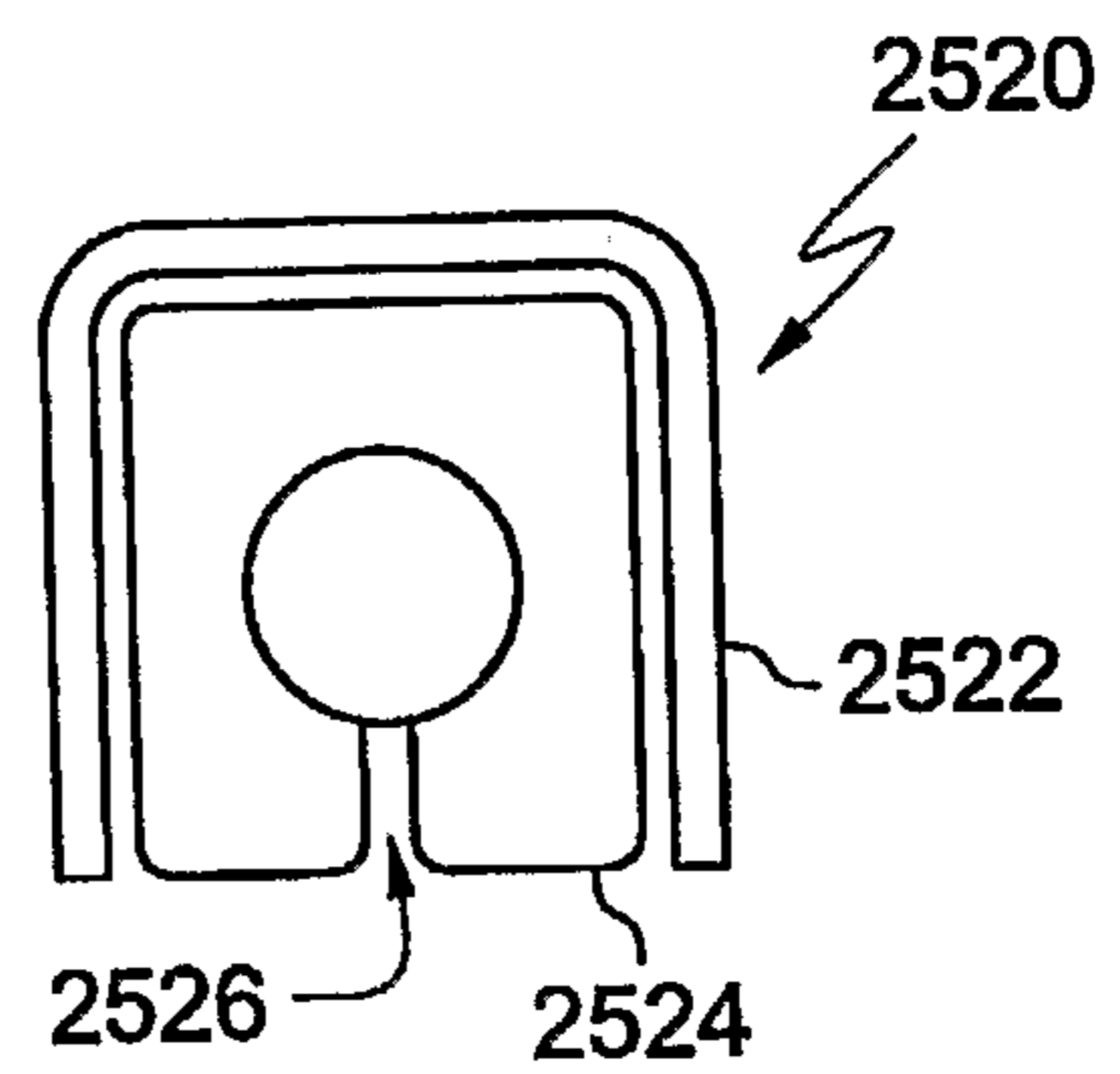

FIG. 28B

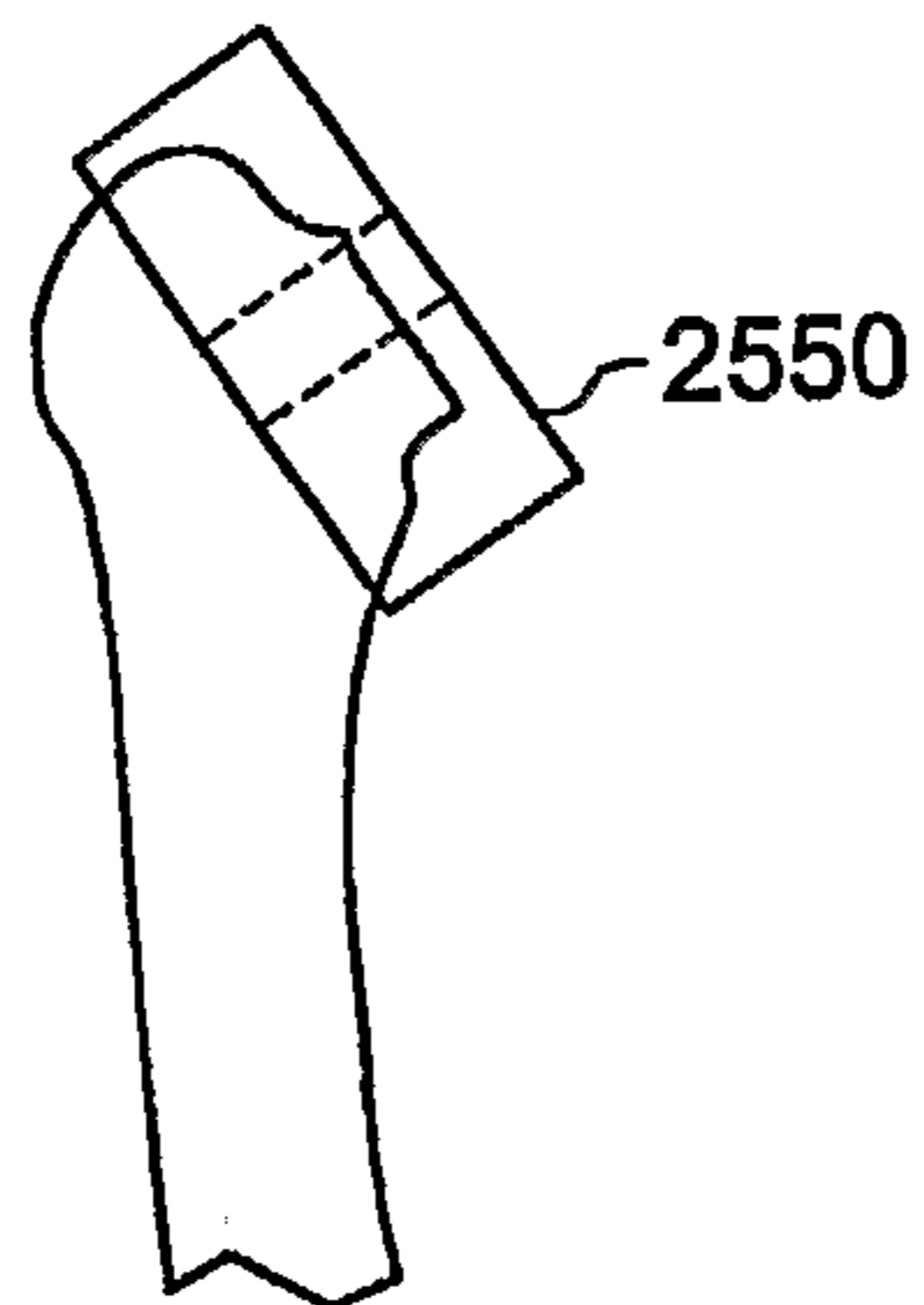

FIG. 28C

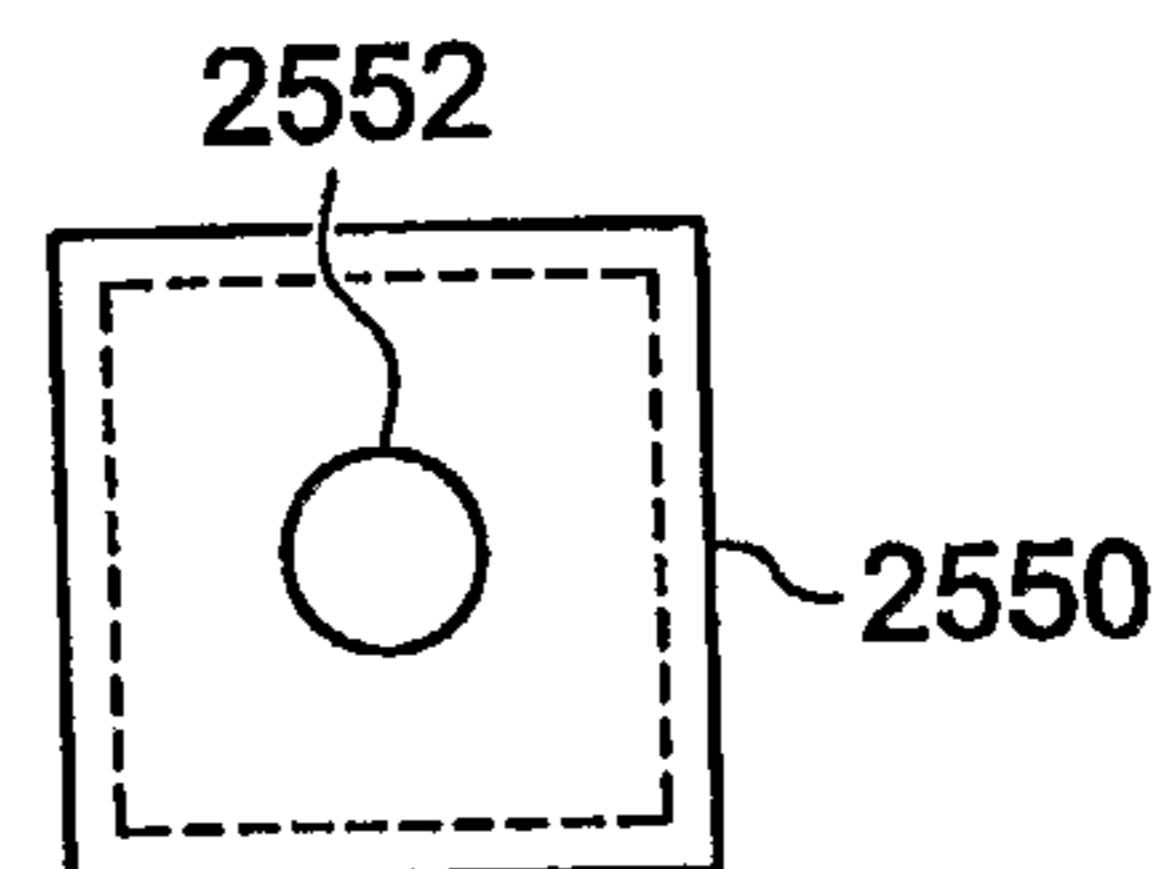

FIG. 28D

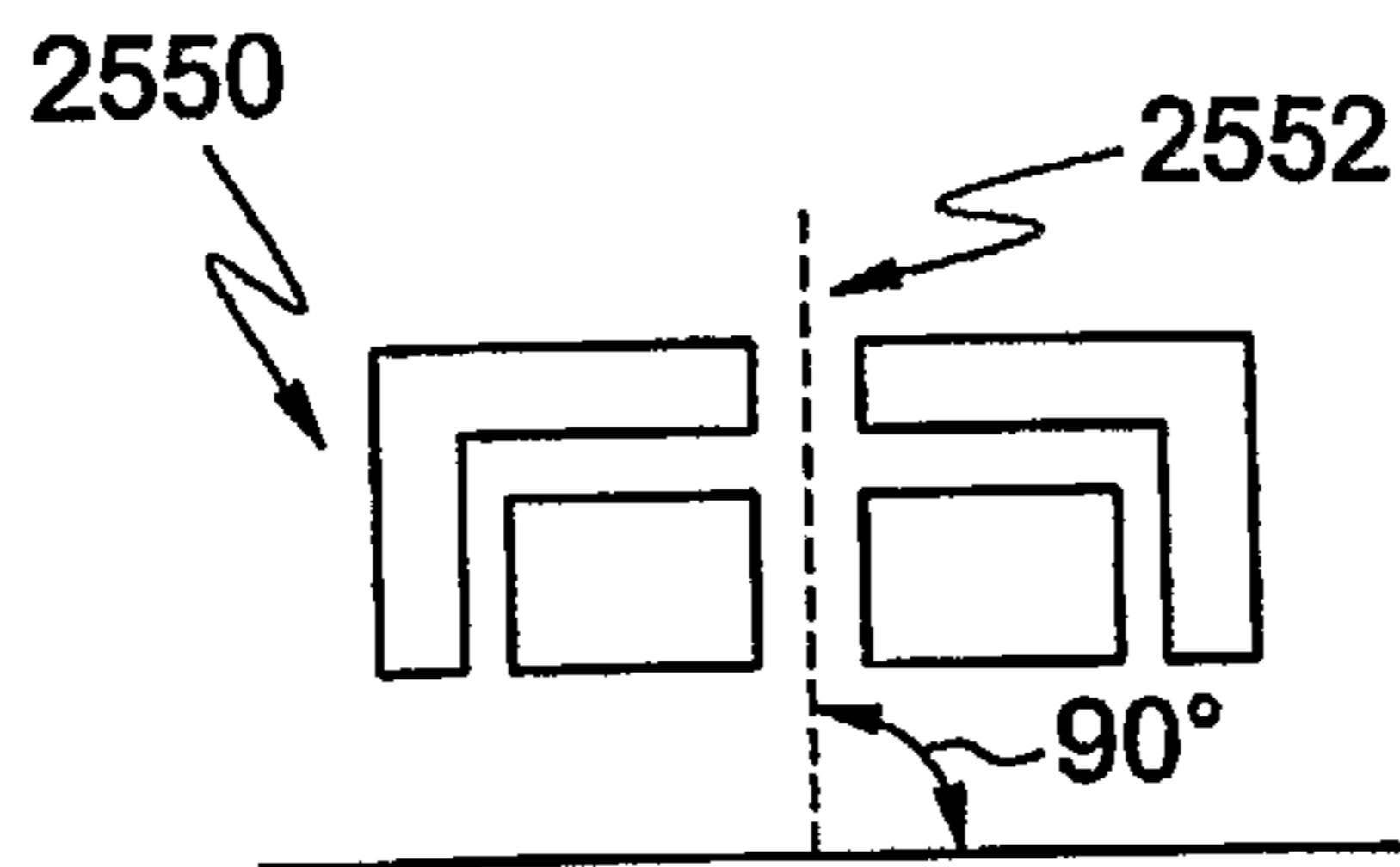

FIG. 28E

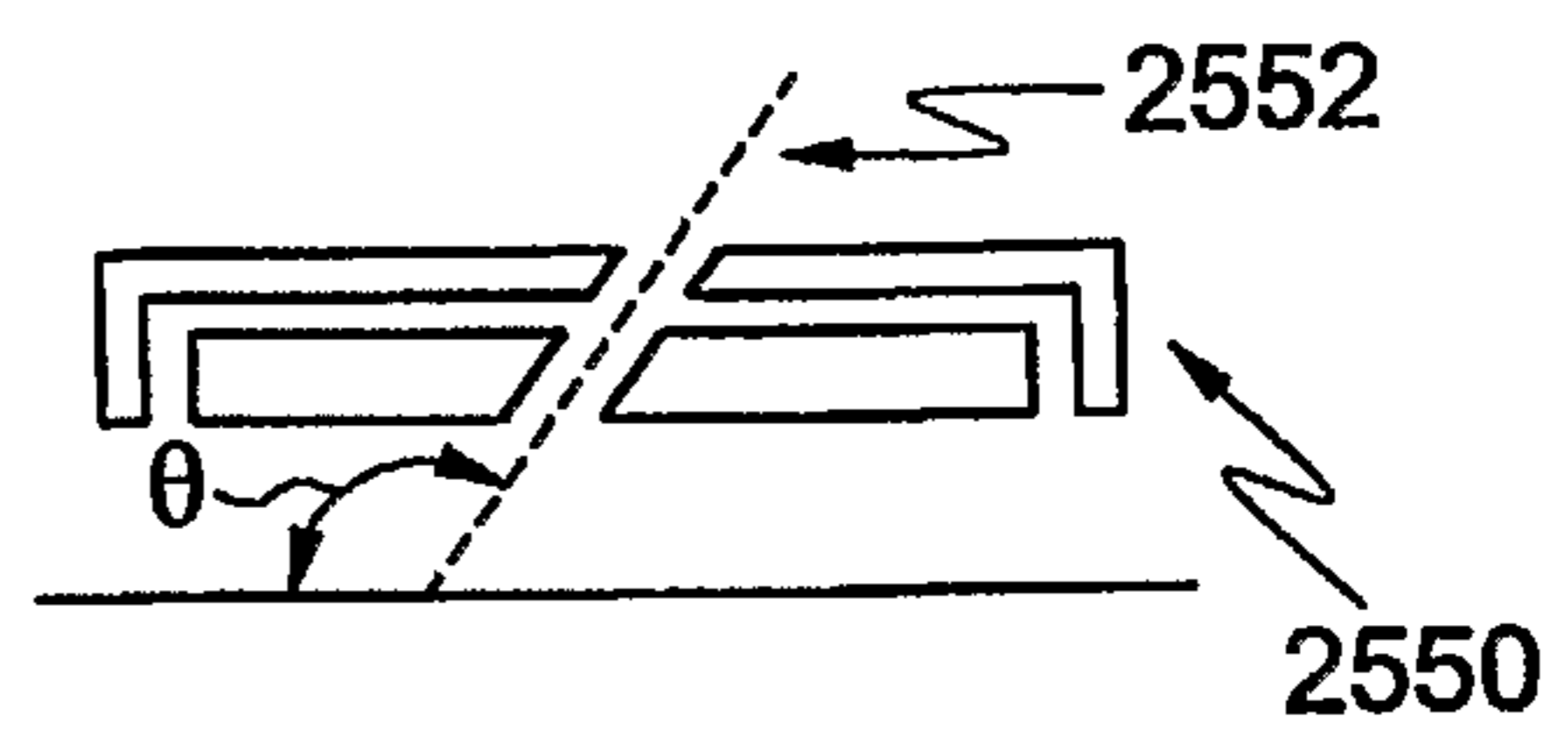

FIG. 28F

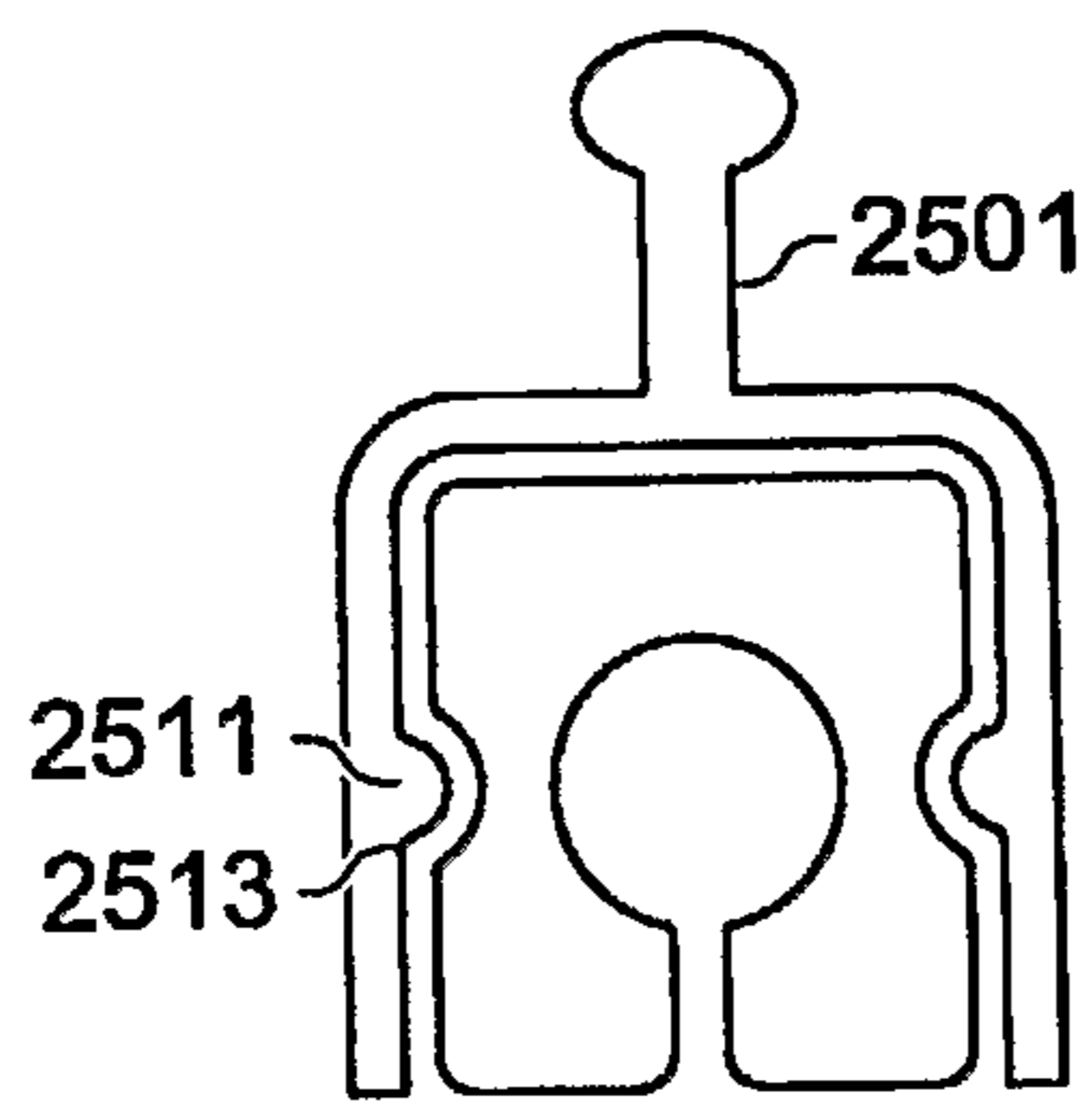

FIG. 28G

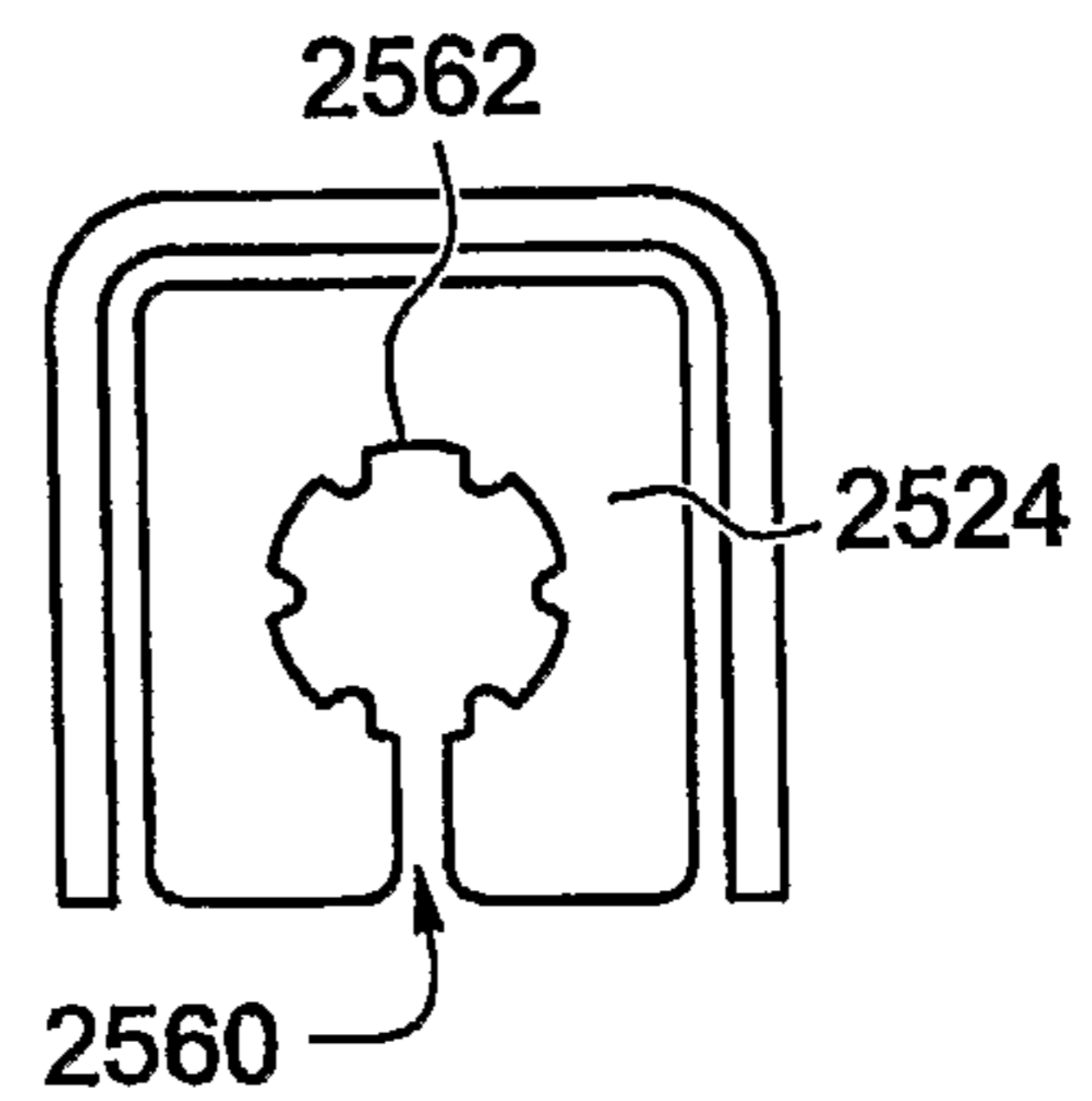

FIG. 28H

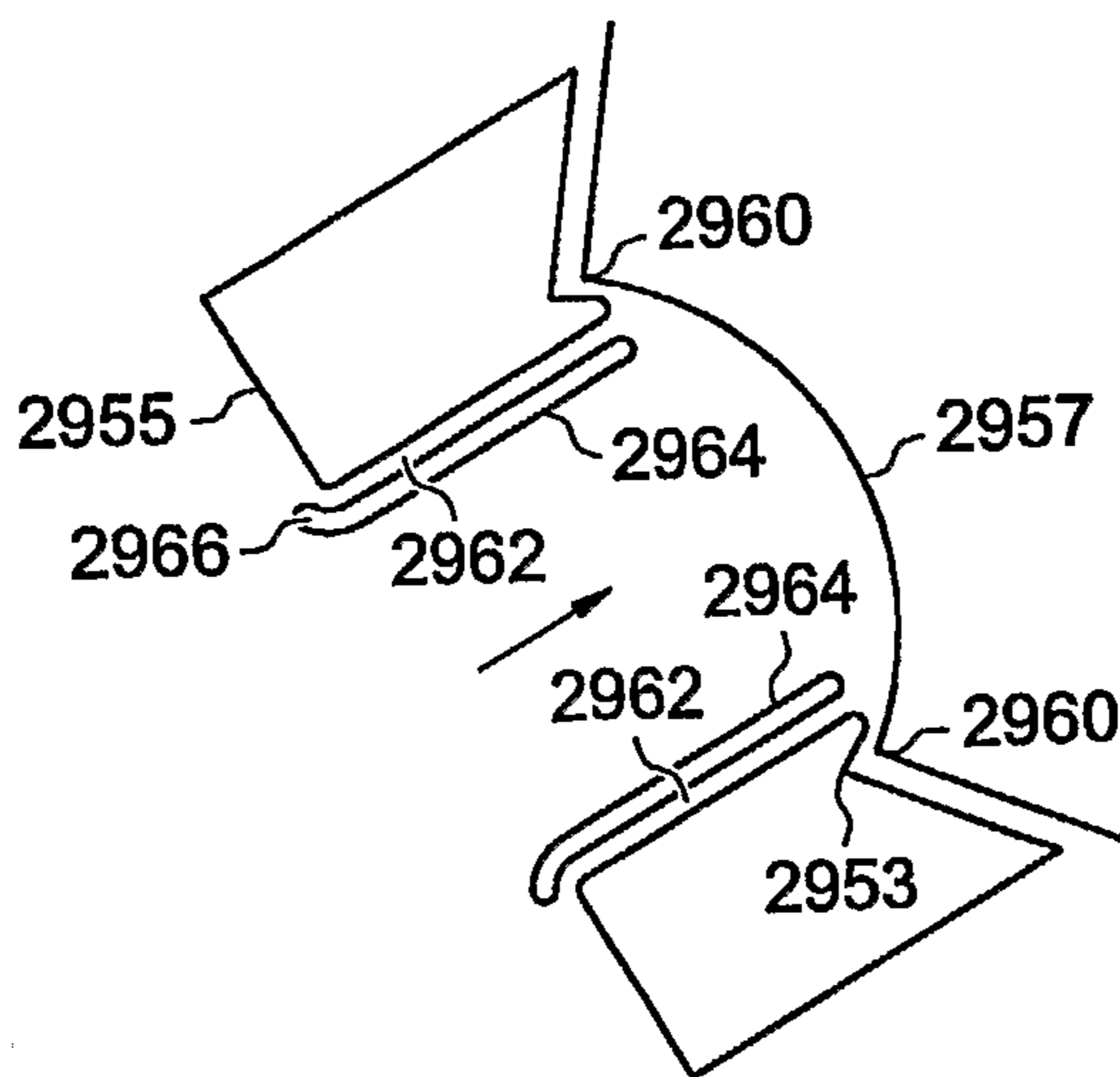

FIG. 29A

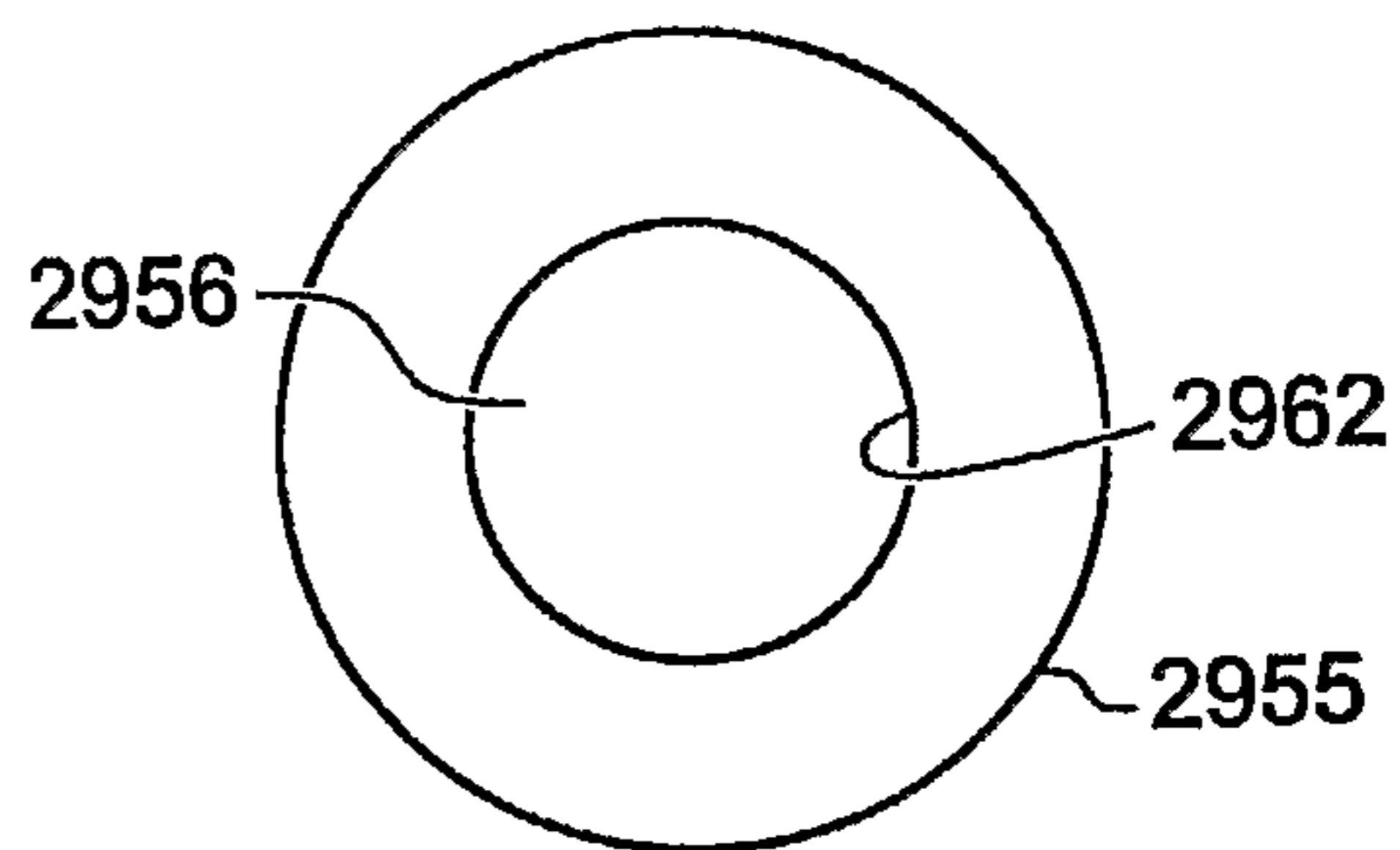

FIG. 29B

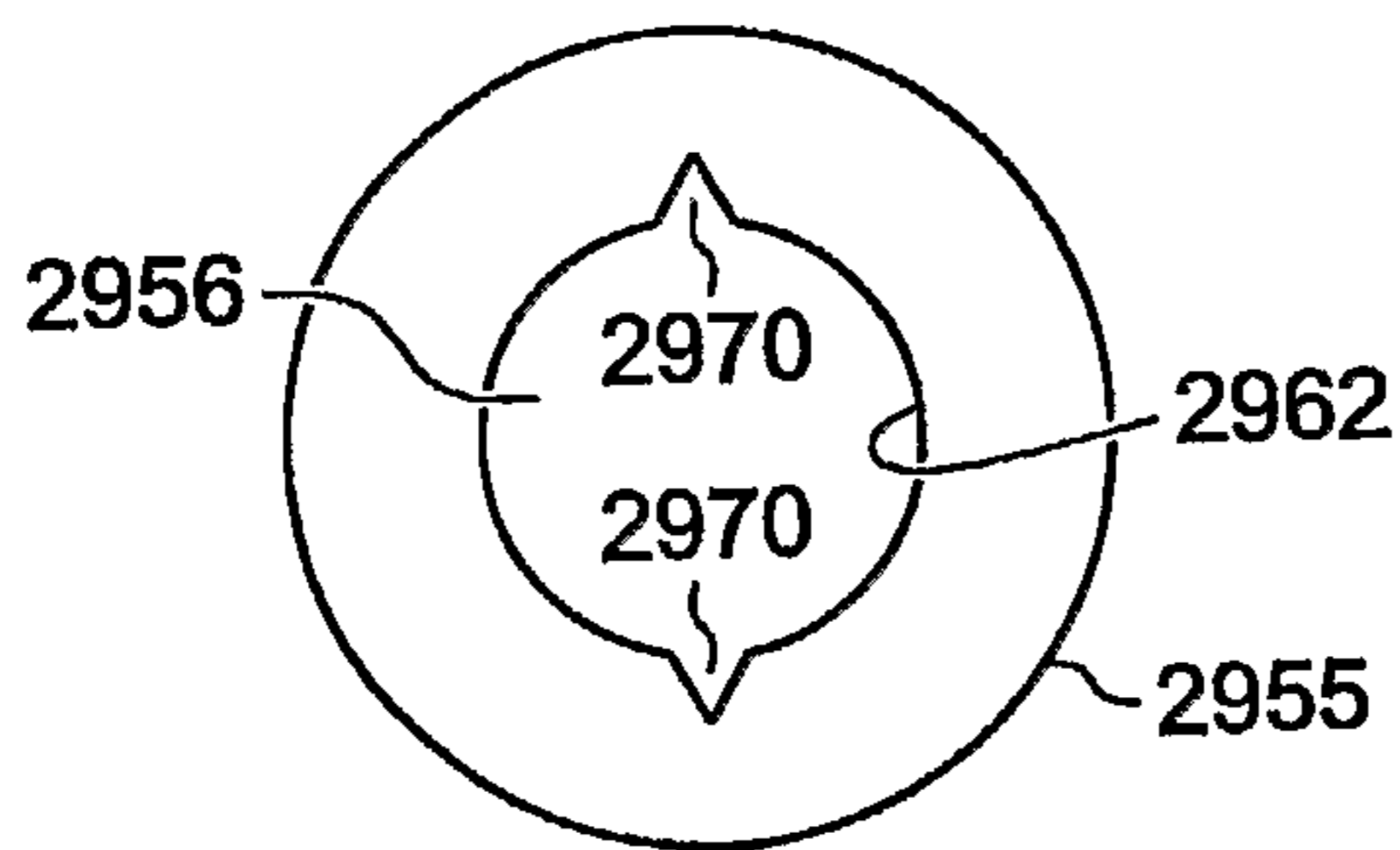

FIG. 29C

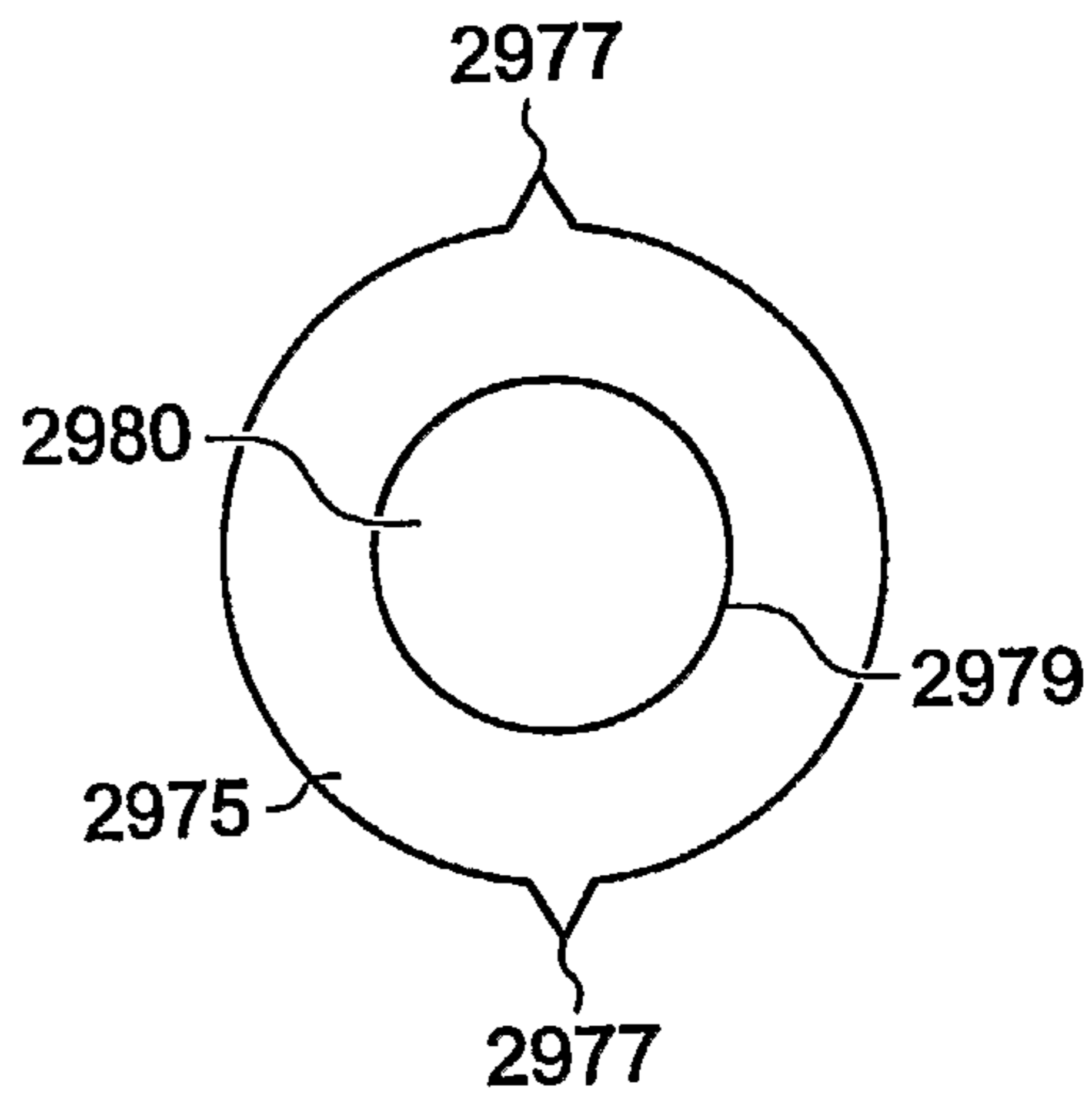

FIG. 29D

