

(19) World Intellectual Property Organization
International Bureau



(43) International Publication Date
6 June 2002 (06.06.2002)

PCT

(10) International Publication Number
WO 02/43585 A1

- (51) International Patent Classification⁷: **A61B 5/00** 2720 San Jose Avenue, Alameda, CA 94501 (US). **AZIZI, Kamrava**; 2462 Paddock Drive, San Ramon, CA 94583 (US). **GOLDBERGER, Daniel, S.**; 644 College Avenue, Boulder, CO 80302 (US).
- (21) International Application Number: PCT/US01/46685
- (22) International Filing Date: 30 November 2001 (30.11.2001) (74) Agent: **DELANEY, Karoline, A.**; Knobbe, Martens, Olson & Bear, LLP, 620 Newport Center Drive, 16th Floor, Newport Beach, CA 92660 (US).
- (25) Filing Language: English
- (26) Publication Language: English (81) Designated States (*national*): AU, CA, JP.
- (30) Priority Data: 09/728,743 1 December 2000 (01.12.2000) US (84) Designated States (*regional*): European patent (DE, FR, GB, IE, IT).
- (71) Applicant: **OPTISCAN BIOMEDICAL CORPORATION** [US/US]; 1105 Atlantic Avenue, Suite 101, Alameda, CA 94501 (US). Published:
— with international search report
— before the expiration of the time limit for amending the claims and to be republished in the event of receipt of amendments
- (72) Inventors: **BRAIG, James, R.**; 280 Mountain Avenue, Piedmont, CA 94611 (US). **HEWETT, Gary, E.**; 19979 Santa Maria Avenue, Castro Valley, CA 94546 (US). **MUNROW, Michael, A.**; 2718 Belmont Canyon Road, Belmont, CA 94002 (US). **CORTELLA, Julian, M.**; 2718 Belmont Canyon Road, Belmont, CA 94002 (US). *For two-letter codes and other abbreviations, refer to the "Guidance Notes on Codes and Abbreviations" appearing at the beginning of each regular issue of the PCT Gazette.*

(54) Title: GLUCOSE MONITORING INSTRUMENT HAVING NETWORK CONNECTIVITY

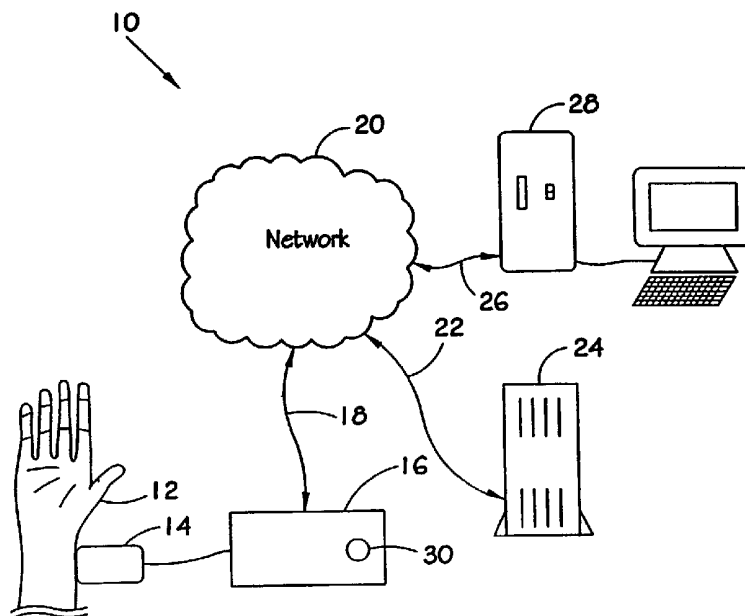

(57) Abstract: A glucose monitoring instrument having network-based communication features which provide a link between patient and practitioner. The glucose monitoring instrument comprises circuitry for communicating data with one or more destination sites on the network which are configured to transmit and receive information to and from the instrument. Instrument measurements are transmitted over the link in addition to information and guidance, to provide increased accuracy, improved program compliance, and patient guidance from a supervisory authority or medical practitioner. In addition, a set of calibration features encourage calibration compliance.



WO 02/43585 A1

GLUCOSE MONITORING INSTRUMENT HAVING NETWORK CONNECTIVITY

BACKGROUND OF THE INVENTION

1. Field of the Invention

This invention pertains generally to medical equipment for measuring blood glucose levels, and more particularly to a blood glucose measuring instrument having internet-based communication features.

2. Description of the Background Art

A patient, having been taught how to use an existing portable glucose monitor is generally required thereafter to independently conduct and record their own measurements. Furthermore, the patient typically is required to both record and assess the measurements without benefit from their practitioner or a supervising authority. Numerous errors can arise from these unsupervised procedures that may result in serious health risks for patients which knowingly, or inadvertently, are not in compliance with medical directives.

Typically, patients using a glucose monitor are given a schedule of measurements to be complied with and a notebook in which to record the measurements. Patients often forget, or in some instances forego, conducting and correctly recording their glucose levels as measured by the instrument. If a patient skips a measurement they may even elect to write down a "likely" number in the notebook as if such a measurement had been taken. Patient interaction with such a manual glucose monitoring instrument therefore provides no assurance of correct measurement and recordation. Furthermore, patients in a myriad of situations may require additional information and assistance with regard to the use and maintenance of their glucose measurement instrument.

In addition, to assure glucose measurement accuracy, a measuring instrument may require periodic calibration and assuring calibration compliance on instruments in the field is burdensome.

Therefore, a need exists for a glucose monitoring system that provides a link between the patient and the practitioner to encourage compliance and facilitate equipment calibration. The present invention satisfies those needs, as well as others, and overcomes deficiencies in current monitoring systems and procedures.

BRIEF SUMMARY OF THE INVENTION

The present invention is a glucose monitoring device with remote communications capabilities. According to an aspect of the invention, a data link is provided between the equipment and a centralized station, or server. The centralized station can monitor important information, such as: equipment calibration, the diligence of a patient taking and recording measurements according to a schedule, and the actual measurements taken by the patient. The centralized station is preferably capable of forwarding information to the patient's physician for evaluation. In addition, the centralized station can have optional capability of locking out the patient if the patient has not paid his or her bills. According to another aspect of the invention, the information is communicated from the glucose monitor directly to the physician. As can be seen, therefore, the invention links the monitoring activities performed by the patient and the assessment of those activities by the physician while reducing the chance of human error introduced into the long-term monitoring and treatment process.

By way of example, and not of limitation, a non-invasive subsurface spectrophotometer instrument equipped with a communications link according to the invention takes the glucose measurements and communicates them over a network, such as the internet. The spectrophotometer instrument comprises data communication circuitry, such as dial-up circuitry, and additional session control protocols which integrate a number of the functions within the instrument for communication over a network connection. A destination site, or sites, on the network are configured to receive information from the instrument and to transmit information and services.

5 An object of the invention is to provide a link from patient to practitioner over which timely communication of pertinent glucose monitoring information can travel.

10 Another object of the invention is to provide for remote monitoring of patient compliance.

Another object of the invention is to provide for remote equipment monitoring and calibration by a central station.

Another object of the invention is to provide for periodic transmission of measurement results.

15 Another object of the invention is to provide network communication over a standardized communications interface.

Another object of the invention is to provide a communications structure which can support data encryption.

Another object of the invention is to aid compliance by alerting the patient, by sound or visual cues, when the time arrives to conduct a measurement.

20 Another object of the invention is to reduce human error in conducting and recording measurements.

Another object of the invention is to eliminate secretive non-compliance, wherein a patient enters fictional measurement data into the measurement log.

Another object of the invention is to provide the capability of generating programmed practitioner warnings when measurements fall outside the bounds of a selected range.

25 Another object of the invention is to provide a panic button which allows a concerned patient to alert their practitioner.

Another object of the invention is to engender practical practitioner guidance to patients.

Another object of the invention is to allow the instrument manufacturer to track compliance and calibration of the glucose monitoring instrument.

30 Another object of the invention is to provide an accurate database that may be used by insurance and pharmaceutical companies.

Further objects and advantages of the invention will be brought out in the following portions of the specification, wherein the detailed description is for the purpose of fully disclosing preferred embodiments of the invention without placing limitations thereon.

BRIEF DESCRIPTION OF THE DRAWINGS

The invention will be more fully understood by reference to the following drawings which are provided for illustrative purposes only:

FIGURE 1 is a functional block diagram showing a glucose monitoring system with network connectivity according to the present invention.

FIGURE 2 is a block diagram of the electronic circuits within the glucose monitoring system of FIG. 1.

FIGURE 3 is a flowchart exemplifying calibration lockout according to one aspect of the present invention.

DETAILED DESCRIPTION OF THE INVENTION

Referring more specifically to the drawings for illustrative purposes, the present invention is embodied in the system generally shown in FIG. 1 through FIG. 3. It will be appreciated that the system may vary as to configuration and as to details of the parts, and that the method may vary as to the specific steps and sequence, without departing from the basic concepts as disclosed herein.

Referring to FIG. 1, a glucose monitoring system 10 is shown connected to remote stations over a network. The hand of a patient 12 is shown positioned to allow a measurement to be performed by glucose detector element 14 which is capable of taking non-invasive measurements of bodily glucose levels. Preferably, measurement element 14 comprises a thermal gradient detector such as a spectrophotometer. A signal processing system 16 of the instrument collects the measurements from detector 14 and processes the data into a set of results. It will be appreciated that the instrument preferably includes input and output devices, such as a display and a set of control inputs (not shown) for communicating information directly to and from the patient.

The combination of detector 14 and processor 16 form a complete non-invasive glucose measuring device that typically would be used in the home of a patient. Examples of glucose monitoring equipment without internet connectivity are described in U.S. Patent Numbers 5,900,632 to Sterling et al. and 5,615,672 to Braig et al., which are both incorporated herein by reference. In accordance with the present invention, however, the signal processing system is equipped with a network interface along with one or more processing elements for processing the measurement signals and for control of network communications.

Data is communicated over the network as determined by the configuration of the system and the state and condition of the measurement being performed. Measurement data may accordingly be communicated to a remote station at the time the measurement is performed, or it may be retained within the instrument and sent to the remote station according to a schedule or other selection criterion. The instrument is capable of comparing each measurement with a set of limits and providing alerts to a supervisory authority regarding excursions therefrom. In FIG. 1 the measurement data is shown being routed through a connection 18 to the internet 20, whose destination is routed through connection 22 to a centralized monitoring computer 24, or a server. The centralized computer is preferably capable of checking the data for emergency conditions and logging the data for later use. In addition, the centralized computer may monitor equipment status for proper operation and calibration. It will be appreciated that multiple servers, or centralized stations, can be provided for communicating

with the blood glucose instruments. Furthermore, the centralized computer may transfer or simultaneously route the data via connection 26 to a computer 28 in the office of a medical practitioner over the internet. Alternatively, the data may be directly sent over the internet to an associated medical practitioner 28 from processor 16. It will be appreciated that the foregoing data routing is provided as an example, and not as a limitation, of the data routing utilized to provide the internet services as described according to the invention. Preferably a panic button 30 provides the patient with a mechanism for alerting a medical practitioner should an important concern arise. In addition, sound and/or visual output is preferably provided by the instrument for signaling the patient when the time arrives to perform a measurement, or of a directive from a supervisory authority as received over the internet.

The present invention, as described herein, provides either a direct or indirect link from the patient to the practitioner. The practitioner is thereby accorded an ability to monitor the status of the patient and may elect to be alerted should deviations in the measurement values or timeliness arise. The system may be configured to transmit measurement data at predetermined intervals, or at the time each measurement is performed. The measurements can be transmitted using various network protocols which include standard internet protocols, encrypted protocols, or email protocols.

In the preferred embodiment of the invention, processor 16 is additionally capable of providing visual or audible cues to the patient when the time arrives to conduct a measurement. These alerts may be augmented by requests, over the internet link of the instrument, from the practitioner. Errors introduced within measurements and recordation within a manual system can thereby be eliminated with the electronically logged measurements. It will be appreciated that the system provides enhanced utility and measurement credibility over the use of an instrument that requires manual logging of the measurements and no practitioner interaction thereof.

Secretive non-compliance may also be eliminated as the patient is not conferred the responsibility of manually logging measurements. In using the instrument according to the present invention, the measurements collected within the instrument by the patient are capable of being transmitted to the practitioner, or centralized station, such that if a patient is not being diligent in conducting measurements, the practitioner may immediately contact the patient to reinforce the need for compliance. In addition, the information provided over the network can be used to warn the practitioner when measurement readings appear abnormal, so that the practitioner may then investigate the situation and verify the status of the patient.

It will be appreciated that the invention has particular utility for patients preferring to receive direct guidance from a practitioner. The information that flows between the patient and the practitioner increases the ability of the practitioner to provide knowledgeable patient guidance.

FIG. 2 illustrates the functional blocks of an embodiment of circuitry 32 for implementing the signal processing hardware 16 shown in FIG. 1. A network connection 34 connects to a network processing circuit, exemplified by an Internet Protocol (IP) circuit or processor 36. Numerous circuits are available for providing internet connectivity, such as the SX-Stack[®] chip from Scenix Semiconductor, and the iChip[®] from Connect One Electronics. These integrated circuit chips and other available chips provide interface layers for supporting a Transmission Control Protocol/Internet Protocol (TCP/IP). The internet protocol chip 36 has an interface 38 with

a control processor section 40, which preferably comprises microcontroller or like. Control processor section 40 in turn has access to conventional memory 42. To provide security and fault tolerance of the instrument it is preferable for the control processor, or the internet protocol circuit, to encrypt and provide verification strings or tokens within the data being sent across the network, and accordingly to decrypt information being received and
5 verify the received strings or tokens. The control processor 40 has an interface 44 with the instrumentation circuits 46, which is in turn configured with an interface 48 to the glucose detection element 14 shown in FIG. 1.

The network link provides a mechanism to facilitate performing and recording glucose measurements under supervision, while it additionally provides for periodic instrument calibration, and the ability to assure both measurement and calibration compliance. Calibration data can be communicated from instruments in the field
10 to the instrument manufacturer, or a service organization, so that instruments and their calibrations may be logged. The disclosed network link can be utilized to provide various mechanisms for assuring calibration compliance. Generally the mechanisms are of two categories, those that provide information or a warning about calibration, and those that prevent use of an instrument which is out of calibration. Preferably instruments which have exceeded their calibration interval, or schedule, are to be locked out from further use until recalibration is
15 performed. For example, the instrument may be set to operate for thirteen months for a given calibration interval of twelve months. The unit preferably issues warnings prior to the expiration of calibration, and warnings of increased severity after the expiration of the calibration interval. If the unit, however, is not properly calibrated by the end of the thirteen months, normal operation ceases, thereby locking out the user after providing an appropriate error message in regard to the expired calibration. Upon recalibration, the calibrated operation interval
20 is restored to provide for another thirteen month period of calibrated operation.

Alternatively, or in addition thereto, a "lockout command" can be sent to the unit over the communication link from the manufacturer which engages a lockout mode of the device, so that continued operation may not be continued until the unit has been serviced. The lockout command could also be sent in the event that the patient has not paid his or her bills, or be sent under other circumstances warranting lockout of the instrument.

Another mode is that of locking out normal instrument use after the expiration of calibration, and allowing limited use thereafter only after a code, or token, has been downloaded from a supervisory site. Although many variations are possible, the code could for instance be provided when a calibration appointment is made for the instrument. To provide continued service and minimize cost, the patient may be allowed to perform calibration checks of the instrument. The patient is supplied with a small set of glucose calibration standards which are read
30 by the instrument once it is put into a calibration mode and preferable connected to a remote site for supervising the process. Should the calibration check pass, wherein the instrument readings fall within normal levels, or be capable of being automatically adjusted thereto, the calibration interval may be extended. Failure of the calibration check would typically necessitate returning the instrument for service.

FIG. 3 illustrates an embodiment of a process 50 for assuring calibration compliance within the glucose measurement instrument by utilizing a lockout mechanism. The programmed instructions associated with the
35 glucose measurement instrument are started at block 52 and initialized at block 54, and a check is made on a

lockout flag at block 56 to determine if it was set during a prior session by a command received from the internet, or due to being out of calibration. Not having been locked out from a prior session, the real-time clock (RTC) of the device is read at block 58 and a calculation is performed at block 60 comparing the current date with the stored calibration date and calibration interval. If upon checking calibration at block 62 the calibration interval has not yet expired, then a calculation is performed at block 64 comparing the current date with the stored calibration date and near-calibration interval. Near-calibration is checked at block 66 and, if calibration is to expire soon, then a user warning is issued at block 68, preferably informing the user of the date of the upcoming expiration of the calibration interval. The lockout flag is cleared at block 70 and processing within the glucose measurement instrument continues with normal instrument functions being accessible at block 72, along with calibration and other limited functions at block 74, until the user shuts down the instrument and processing ends at block 76. If the lockout flag was set from a prior instrument operation, or the calibration interval was exceeded, then a lockout flag would be set at block 78, and the instrument functionality would thereby be restricted to execution of the calibration procedures and other limited functions at block 78 while the normal instrument functionality would not be accessible. The calibration procedure itself may be augmented and improved by providing interaction between the servicing party and the manufacturer, such interaction may include providing guidance information to the servicing party, and the collection of measurement information by the manufacturer.

It will be appreciated that the present invention provides functionality beyond that which can be provided by a stand-alone glucose measurement instrument, as the practitioner, or practitioners office, is brought back into the glucose measurement process to confer a portion of the benefits normally associated with an office visit. It will be recognized that although not providing equivalent results, the features described for the embodiment of a non-invasive glucose monitoring instrument are generally applicable to glucose monitoring hardware in which invasive measurements are taken. The aforesaid description of the invention illustrates how these features provide the capability for two-way data flow which facilitates the conducting and recording of correct measurements while encouraging compliance in regard to both measurements and instrument calibration. Furthermore, the data collected by the system may be utilized by others in addition to the practitioner, such as pharmaceutical companies which may be provided data access to alter or administer medication programs, and insurance companies which may require data regarding patient diligence according to the specified treatment program.

Accordingly, it will be seen that the present invention provides numerous benefits for patients needing to closely monitor blood glucose levels and it can be implemented with numerous variations and alternatives obvious to those skilled in the art.

Although the description above contains many specificities, these should not be construed as limiting the scope of the invention but as merely providing illustrations of some of the presently preferred embodiments of this invention. Thus the scope of this invention should be determined by the appended claims and their legal equivalents. Therefore, it will be appreciated that the scope of the present invention fully encompasses other embodiments which may become obvious to those skilled in the art, and that the scope of the present invention

is accordingly to be limited by nothing other than the appended claims, in which reference to an element in the singular is not intended to mean "one and only one" unless explicitly so stated, but rather "one or more." All structural, chemical, and functional equivalents to the elements of the above-described preferred embodiment that are known to those of ordinary skill in the art are expressly incorporated herein by reference and are intended to be encompassed by the present claims. Moreover, it is not necessary for a device or method to address each and every problem sought to be solved by the present invention, for it to be encompassed by the present claims. Furthermore, no element, component, or method step in the present disclosure is intended to be dedicated to the public regardless of whether the element, component, or method step is explicitly recited in the claims. No claim element herein is to be construed under the provisions of 35 U.S.C. 112, sixth paragraph, unless the element is expressly recited using the phrase "means for."

WHAT IS CLAIMED IS:

1. In a glucose monitoring instrument having a glucose detection element and signal processing circuitry, the improvement comprising:
- 5 (a) means for providing network connectivity of the instrument for the communication of measurements and information between a patient and a supervisory authority, such as a medical practitioner; and
- (b) network protocol associated with said instrument capable of providing said network connectivity.
2. A glucose monitoring instrument, comprising:
- (a) means for collecting glucose readings from a patient; and
- 10 (b) means for communicating said glucose readings over a network to a remote station to allow a supervisory authority, such as a medical practitioner, to oversee data collection and patient treatment.
3. In a glucose measurement instrument having means for measuring patient glucose information and processing that information into one or more readings, the improvement comprising:
- (a) a network communications interface capable of communicating over a connected network; and
- 15 (b) a controller configured for executing a series of programmed instructions which provide for the communication of measurements and information with a remote station to allow a supervisory authority, such as a medical practitioner, to oversee patient data collection and compliance with a treatment program.
4. In a glucose measurement instrument as recited in claim 3, the improvement further comprising communication of measurement data and time of measurement.
5. In a glucose measurement instrument as recited in claim 3, the improvement further comprising
- 20 means for communicating a patient initiated alert to said remote station to allow for practitioner intervention on behalf of said patient.
6. In a glucose measurement instrument as recited in claim 4, the improvement further comprising means for communicating calibration information to a remote station to encourage calibration compliance.
7. An apparatus for monitoring the glucose levels of a patient comprising:
- 25 (a) a glucose detector element capable of taking measurements of bodily glucose levels;
- (b) a network communications interface; and
- (c) a processor operating from programmed instructions capable of controlling measurements from the glucose detector element and of communicating glucose measurement information via the network communications interface to a remote location.
- 30 8. An apparatus as recited in claim 7, wherein the glucose measurement information comprises measurement data, and time of measurement.
9. An apparatus as recited in claim 7, further comprising means for communicating a patient initiated alert to said remote location to allow for practitioner intervention on behalf of said patient.
10. An apparatus as recited in claim 7, further comprising means for communicating calibration
- 35 information to a remote station for monitoring and controlling aspects of instrument calibration to encourage calibration compliance.

11. An apparatus as recited in claim 7, wherein the glucose detector performs non-invasive blood glucose measurements.
12. An apparatus as recited in claim 7, wherein the glucose detector element comprises a thermal gradient spectrophotometer.
- 5 13. An apparatus as recited in claim 7, further comprising programmed instructions for the processor to generate alerts to inform the patient when the time arrives for taking a measurement according to a predetermined schedule or network communicated practitioner directive.
14. An apparatus as recited in claim 7, further comprising programmed instructions for the processor to generate warnings transmitted to a remote location when measured glucose levels exceed the bounds of a
10 preselected range.
15. An apparatus as recited in claim 7, further comprising a panic button which upon activation sends an alert to a remote location over the network communication interface to alert a supervisory authority so that intercession on the patients behalf may be instituted.
16. An apparatus as recited in claim 7, wherein periodic maintenance and calibration information
15 is communicated over the network communication interface to a remote location.
17. An apparatus as recited in claim 16, further comprising a lockout mode that is entered upon receiving commands over the network communication interface, the lockout mode restricting the functionality of the instrument which may be accessed by the user.
18. An apparatus as recited in claim 16, further comprising a lockout mode that is entered upon
20 determining that the calibration interval for the instrument has been exceeded, the lockout mode restricting which functions of the instrument which may currently accessed by the user.
19. A method of providing supervision of blood glucose measurements, comprising the steps of:
- (a) collecting a glucose measurement on a portable blood glucose instrument;
- (b) processing the glucose measurement into a set of data values; and
- 25 (c) communicating said data values over a network to a remote station such that a supervisory authority, such as a medical practitioner, may oversee the data collection and patient treatment program, the communication of said data values being provided by a network communications interface within said blood glucose instrument.

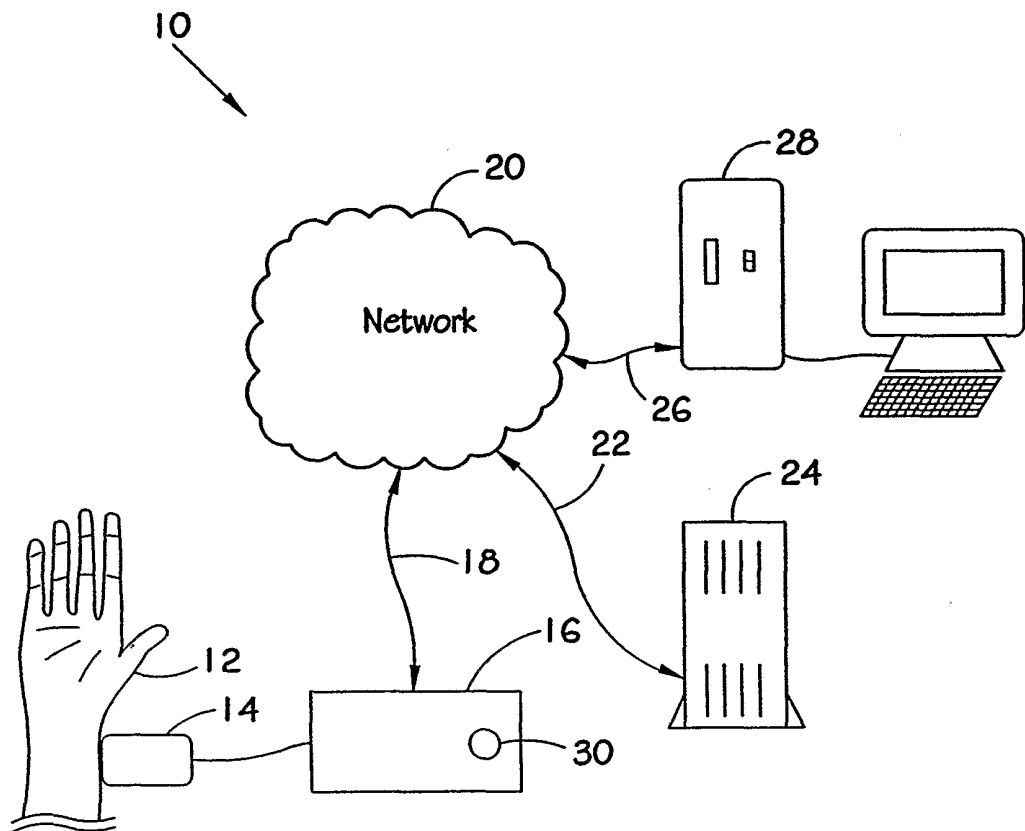

Fig. 1

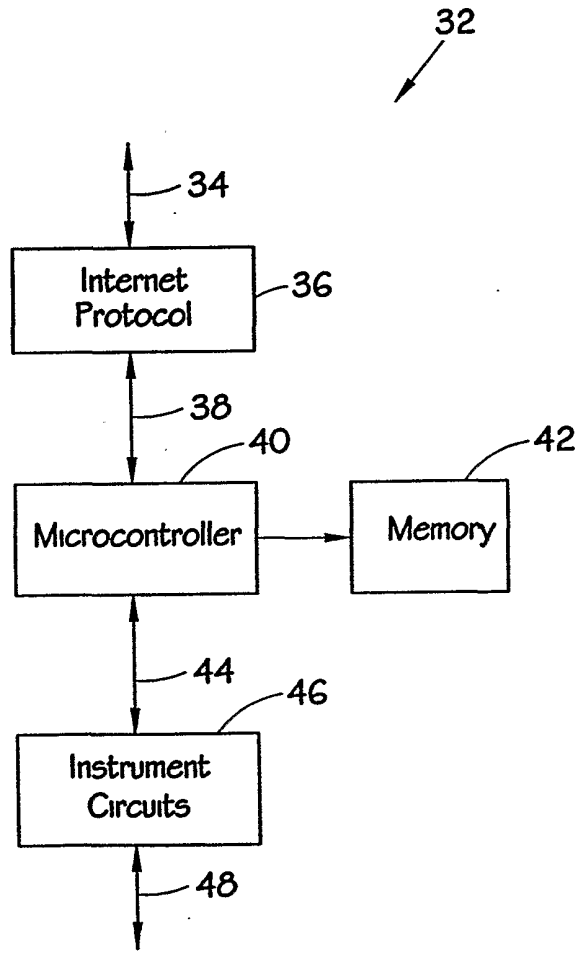
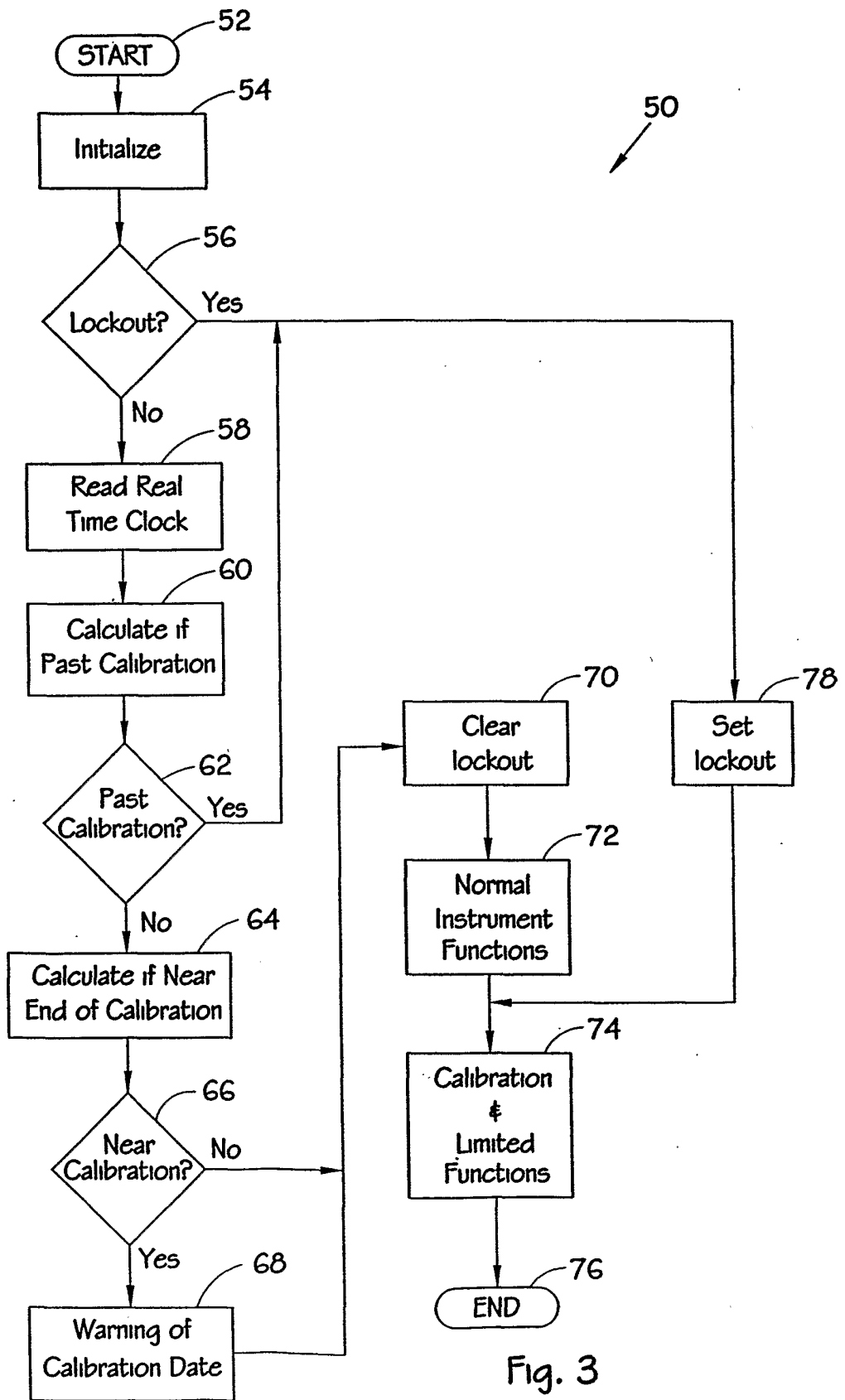

Fig. 2



INTERNATIONAL SEARCH REPORT

In **International Application No**
PCT/US 01/46685

A. CLASSIFICATION OF SUBJECT MATTER
IPC 7 A61B5/00

According to International Patent Classification (IPC) or to both national classification and IPC

B. FIELDS SEARCHED

Minimum documentation searched (classification system followed by classification symbols)
IPC 7 A61B

Documentation searched other than minimum documentation to the extent that such documents are included in the fields searched

Electronic data base consulted during the international search (name of data base and, where practical, search terms used)

WPI Data, PAJ, EPO-Internal

C. DOCUMENTS CONSIDERED TO BE RELEVANT

Category *	Citation of document, with indication, where appropriate, of the relevant passages	Relevant to claim No.
X	WO 00 28460 A (LIFESTREAM TECHNOLOGIES INC; COAD NOAH M (US); MOODY JAMES L (US);) 18 May 2000 (2000-05-18) page 18, line 4 - line 15 page 21, line 24 -page 22, line 22 ---	1-4,6,7, 10,16,19
A		11,12
X	EP 0 970 655 A (CARPE DIEM COMERCIAL SANITARIA) 12 January 2000 (2000-01-12) column 4, line 37 - line 44 column 15, line 20 - line 42 column 20, line 16 - line 21 column 21, line 45 - line 49 column 25, line 40 - line 44 column 30, line 39 - line 43 ---	1-3,5,7, 9,13-15, 19
A		11,12
	-/--	

Further documents are listed in the continuation of box C.

Patent family members are listed in annex.

* Special categories of cited documents:

- *A* document defining the general state of the art which is not considered to be of particular relevance
- *E* earlier document but published on or after the international filing date
- *L* document which may throw doubts on priority claim(s) or which is cited to establish the publication date of another citation or other special reason (as specified)
- *O* document referring to an oral disclosure, use, exhibition or other means
- *P* document published prior to the international filing date but later than the priority date claimed

- *T* later document published after the international filing date or priority date and not in conflict with the application but cited to understand the principle or theory underlying the invention
- *X* document of particular relevance; the claimed invention cannot be considered novel or cannot be considered to involve an inventive step when the document is taken alone
- *Y* document of particular relevance; the claimed invention cannot be considered to involve an inventive step when the document is combined with one or more other such documents, such combination being obvious to a person skilled in the art.
- *&* document member of the same patent family

Date of the actual completion of the international search

26 April 2002

Date of mailing of the international search report

07/05/2002

Name and mailing address of the ISA

European Patent Office, P.B. 5818 Patentlaan 2
NL - 2280 HV Rijswijk
Tel. (+31-70) 340-2040, Tx. 31 651 epo nl,
Fax: (+31-70) 340-3016

Authorized officer

Knüpling, M

INTERNATIONAL SEARCH REPORT

International Application No
PCT/US 01/46685

C.(Continuation) DOCUMENTS CONSIDERED TO BE RELEVANT		
Category °	Citation of document, with indication, where appropriate, of the relevant passages	Relevant to claim No.
X	WO 00 53085 A (OPTISCAN BIOMEDICAL CORP) 14 September 2000 (2000-09-14) page 11, line 18 - line 20 page 18, line 13 - line 16 page 27, line 18 - line 2	1-3,7, 10-12, 16,19
A	----- page 27, line 18 - line 2	6
X	WO 00 32258 A (AASMUL SOEREN; NOVONORDISK AS (DK); CHRISTENSEN LARS HOFMANN (DK);) 8 June 2000 (2000-06-08) page 7, line 32 -page 8, line 7 page 9, line 8 - line 12 page 12, line 15 - line 20 page 14, line 30 -page 15, line 7 page 32, line 5 - line 11 -----	1-5,7-9, 14,19
A	WO 99 25110 A (I FLOW CORP) 20 May 1999 (1999-05-20) page 4, line 19 - line 34 -----	1-3,5-7, 9,10, 15-19

INTERNATIONAL SEARCH REPORT

 In International Application No
 PCT/US 01/46685

Patent document cited in search report		Publication date	Patent family member(s)	Publication date
WO 0028460	A	18-05-2000	AU 2023100	A 29-05-2000
			EP 1133747	A2 19-09-2001
			WO 0028460	A2 18-05-2000
EP 0970655	A	12-01-2000	ES 2124186	A1 16-01-1999
			AU 5561698	A 07-08-1998
			BR 9807497	A 21-03-2000
			EP 0970655	A1 12-01-2000
			CN 1244104	T 09-02-2000
			WO 9831275	A1 23-07-1998
WO 0053085	A	14-09-2000	US 6198949	B1 06-03-2001
			AU 3523000	A 28-09-2000
			EP 1158893	A1 05-12-2001
			WO 0053085	A1 14-09-2000
WO 0032258	A	08-06-2000	AU 1376500	A 19-06-2000
			AU 1503200	A 19-06-2000
			BR 9916142	A 04-09-2001
			BR 9916149	A 04-09-2001
			CN 1329511	T 02-01-2002
			CN 1329471	T 02-01-2002
			CZ 20011702	A3 17-10-2001
			CZ 20011815	A3 16-01-2002
			WO 0032088	A1 08-06-2000
			WO 0032258	A1 08-06-2000
			EP 1144028	A1 17-10-2001
			EP 1135056	A1 26-09-2001
			NO 20012623	A 13-07-2001
			NO 20012655	A 25-07-2001
WO 9925110	A	20-05-1999	AU 1584099	A 31-05-1999
			BR 9814637	A 27-11-2001
			CA 2310243	A1 20-05-1999
			CN 1295754	T 16-05-2001
			EP 1036464	A1 20-09-2000
			HU 0100368	A2 28-05-2001
			JP 2001522674	T 20-11-2001
			NO 20002468	A 11-07-2000
			PL 340546	A1 12-02-2001
			TR 200001711	T2 22-01-2001
			WO 9925110	A1 20-05-1999