



## INTERNATIONAL APPLICATION PUBLISHED UNDER THE PATENT COOPERATION TREATY (PCT)

<b>(51) International Patent Classification <sup>6</sup> :</b>  <b>B64G</b>	<b>A2</b>	<b>(11) International Publication Number:</b> <b>WO 98/33704</b>  <b>(43) International Publication Date:</b> 6 August 1998 (06.08.98)
<b>(21) International Application Number:</b> PCT/US98/01924  <b>(22) International Filing Date:</b> 4 February 1998 (04.02.98)  <b>(30) Priority Data:</b> 60/036,864      4 February 1997 (04.02.97)      US 60/041,465      25 March 1997 (25.03.97)      US 60/044,318      24 April 1997 (24.04.97)      US 60/048,244      2 June 1997 (02.06.97)      US  <b>(71)(72) Applicant and Inventor:</b> BELBRUNO, Edward, A. [US/US]; Suite 502, 500 North Robert Street, St. Paul, MN 55101 (US).  <b>(74) Agents:</b> DONNER, Irah, H. et al.; Pepper Hamilton LLP, 1300 Nineteenth Street, N.W., Washington, DC 20036-1685 (US).		<b>(81) Designated States:</b> AL, AM, AT, AU, AZ, BA, BB, BG, BR, BY, CA, CH, CN, CZ, DE, DK, EE, ES, FI, GB, GE, GH, GM, GW, HU, ID, IL, IS, JP, KE, KG, KR, KZ, LC, LK, LR, LS, LT, LU, LV, MD, MG, MK, MN, MW, MX, NO, NZ, PL, PT, RO, RU, SD, SE, SG, SI, SK, SL, TJ, TM, TR, TT, UA, UG, US, UZ, VN, YU, ZW, ARIPO patent (GH, GM, KE, LS, MW, SD, SZ, UG, ZW), Eurasian patent (AM, AZ, BY, KG, KZ, MD, RU, TJ, TM), European patent (AT, BE, CH, DE, DK, ES, FI, FR, GB, GR, IE, IT, LU, MC, NL, PT, SE), OAPI patent (BF, BJ, CF, CG, CI, CM, GA, GN, ML, MR, NE, SN, TD, TG).  <b>Published</b> <i>Without international search report and to be republished upon receipt of that report.</i>
<b>(54) Title:</b> NEW PROCEDURE FOR GENERATING OPERATIONAL BALLISTIC CAPTURE TRANSFER USING A COMPUTER IMPLEMENTED PROCESS		
<b>(57) Abstract</b>  A method generates an operational ballistic capture transfer for an object emanating substantially at earth or earth orbit to arrive at the moon or moon orbit using a computer implemented process. The method includes the steps of entering parameters including velocity magnitude $V_E$ , flight path angle $\gamma_E$ , and implementing a forward targeting process by varying the velocity magnitude $V_E$ , and the flight path angle $\gamma_E$ for convergence of target variables at the moon. The target variables include radial distance, $r_M$ , and inclination $i_M$ . The method also includes the step of iterating the forward targeting process until sufficient convergence to obtain the operational ballistic capture transfer from the earth or the earth orbit to the moon or the moon orbit.		

**FOR THE PURPOSES OF INFORMATION ONLY**

Codes used to identify States party to the PCT on the front pages of pamphlets publishing international applications under the PCT.

AL	Albania	ES	Spain	LS	Lesotho	SI	Slovenia
AM	Armenia	FI	Finland	LT	Lithuania	SK	Slovakia
AT	Austria	FR	France	LU	Luxembourg	SN	Senegal
AU	Australia	GA	Gabon	LV	Latvia	SZ	Swaziland
AZ	Azerbaijan	GB	United Kingdom	MC	Monaco	TD	Chad
BA	Bosnia and Herzegovina	GE	Georgia	MD	Republic of Moldova	TG	Togo
BB	Barbados	GH	Ghana	MG	Madagascar	TJ	Tajikistan
BE	Belgium	GN	Guinea	MK	The former Yugoslav Republic of Macedonia	TM	Turkmenistan
BF	Burkina Faso	GR	Greece	ML	Mali	TR	Turkey
BG	Bulgaria	HU	Hungary	MN	Mongolia	TT	Trinidad and Tobago
BJ	Benin	IE	Ireland	MR	Mauritania	UA	Ukraine
BR	Brazil	IL	Israel	MW	Malawi	UG	Uganda
BY	Belarus	IS	Iceland	MX	Mexico	US	United States of America
CA	Canada	IT	Italy	NE	Niger	UZ	Uzbekistan
CF	Central African Republic	JP	Japan	NL	Netherlands	VN	Viet Nam
CG	Congo	KE	Kenya	NO	Norway	YU	Yugoslavia
CH	Switzerland	KG	Kyrgyzstan	NZ	New Zealand	ZW	Zimbabwe
CI	Côte d'Ivoire	KP	Democratic People's Republic of Korea	PL	Poland		
CM	Cameroon	KR	Republic of Korea	PT	Portugal		
CN	China	KZ	Kazakistan	RO	Romania		
CU	Cuba	LC	Saint Lucia	RU	Russian Federation		
CZ	Czech Republic	LI	Liechtenstein	SD	Sudan		
DE	Germany	LK	Sri Lanka	SE	Sweden		
DK	Denmark	LR	Liberia	SG	Singapore		
EE	Estonia						

NEW PROCEDURE FOR GENERATING OPERATIONAL BALLISTIC  
CAPTURE TRANSFER USING A COMPUTER IMPLEMENTED  
PROCESS

RELATED APPLICATIONS

This patent application claims priority from U.S. provisional patent application serial number 60/036,864, filed February 4, 1997, U.S. provisional patent application serial number 60/041,465, filed March 25, 1997, U.S. provisional patent application serial number 60/044,318 filed April 24, 1997, U.S. provisional patent application serial number 60/048,244, filed June 2, 1997, all to inventor Edward A. Belbruno, and all of which are incorporated herein by reference, including all references cited therein.

BACKGROUND OF THE INVENTION

Field of the Invention

This invention relates in general to methods for space travel, and in particular, to methods for an object, such as a satellite, space craft, and the like, to be placed in lunar orbit around the moon, and/or orbit around other planets including earth.

Background of the Related Art

The study of motion of objects, including celestial objects, originated, in part, with Newtonian mechanics. During the eighteenth and nineteenth centuries, Newtonian mechanics, using a law of motion described by acceleration provided an orderly and useful framework to solve most of the

celestial mechanical problems of interest for that time. In order to specify the initial state of a Newtonian system, the velocities and positions of each particle must be specified.

However, in the mid-nineteenth century, Hamilton recast the formulation of dynamical systems by introducing the so-called Hamiltonian function,  $H$ , which represents the total energy of the system expressed in terms of the position and momentum, which is a first-order differential equation description. This first order aspect of the Hamiltonian, which represents a universal formalism for modeling dynamical systems in physics, implies a determinism for classical systems, as well as a link to quantum mechanics.

By the early 1900s, Poincare understood that the classical Newtonian three-body problem gave rise to a complicated set of dynamics that was very sensitive to dependence on initial conditions, which today is referred to as "chaos theory." The origin of chaotic motion can be traced back to classical (Hamiltonian) mechanics which is the foundation of (modern) classical physics. In particular, it was nonintegrable Hamiltonian mechanics and the associated nonlinear problems which posed both the dilemma and ultimately the insight into the occurrence of randomness and unpredictability in apparently completely deterministic systems.

The advent of the computer provided the tools which were hitherto lacking to earlier researchers, such as Poincare, and which relegated the nonintegrable Hamiltonian mechanics from the mainstream of physics research. With the development of computational methodology combined with deep intuitive insights, the early 1960s gave

rise to the formulation of the KAM theorem, named after A.N. Kolmogorov, V.I. Arnold, and J. Moser, that provided the conditions for randomness and unpredictability for nearly nonintegrable Hamiltonian systems.

Within the framework of current thinking, almost synonymous with certain classes of nonlinear problems is the so-called chaotic behavior. Chaos is not just simply disorder, but rather an order without periodicity. An interesting and revealing aspect of chaotic behavior is that it can appear random when the generating algorithms are finite, as described by the so-called logistic equations.

Chaotic motion is important for astrophysical (orbital) problems in particular, simply because very often within generally chaotic domains, patterns of ordered motion can be interspersed with chaotic activity at smaller scales. Because of the scale characteristics, the key element is to achieve sufficiently high resolving power in the numerical computation in order to describe precisely the quantitative behavior that can reveal certain types of chaotic activity. Such precision is required because instead of the much more familiar spatial or temporal periodicity, a type of scale invariance manifests itself. This scale invariance, discovered by Feigenbaum for one-dimensional mappings, provided for the possibility of analyzing renormalization group considerations within chaotic transitions.

Insights into stochastic mechanics have also been derived from related developments in nonlinear analysis, such as the relationship between nonlinear dynamics and modern ergodic theory. For example, if time averages along a trajectory on an energy surface are equal to the ensemble averages over the

entire energy surface, a system is said to be ergodic on its energy surface. In the case of classical systems, randomness is closely related to ergodicity. When characterizing attractors in dissipative systems, similarities to ergodic behavior are encountered.

An example of a system's inherent randomness is the work of E.N. Lorenz on thermal convection, which demonstrated that completely deterministic systems of three ordinary differential equations underwent irregular fluctuations. Such bounded, nonperiodic solutions which are unstable can introduce turbulence, and hence the appellation "chaos," which connotes the apparent random motion of some mappings. One test that can be used to distinguish chaos from true randomness is through invocation of algorithmic complexity; a random sequence of zeros and ones can only be reproduced by copying the entire sequence, i.e., periodicity is of no assistance.

The Hamiltonian formulation seeks to describe motion in terms of first-order equations of motion. The usefulness of the Hamiltonian viewpoint lies in providing a framework for the theoretical extensions into many physical models, foremost among which is celestial mechanics. Hamiltonian equations hold for both special and general relativity. Furthermore, within classical mechanics it forms the basis for further development, such as the familiar Hamilton-Jacobi method and, of even greater extension, the basis for perturbation methods. This latter aspect of Hamiltonian theory will provide a starting point for the analytical discussions to follow in this brief outline.

As already mentioned, the Hamiltonian formulation basically seeks to describe motion in terms of first-order equations of motion. Generally, the motion of an integrable Hamilton system with  $N$  degrees of freedom is periodic and confined to the  $N$ -torus as shown in FIG. 1. FIG. 1 depicts an integrable system with two degrees of freedom on a torus, and a closed orbit of a trajectory. The KAM tori are concentric versions of the single torus. Hamiltonian systems for which  $N=1$  are all integrable, while the vast majority of systems with  $N$  greater than or equal to 2 become nonintegrable.

An integral of motion which makes it possible to reduce the order of a set of equations, is called the first integral. To integrate a set of differential equations of the order  $2N$ , that same number of integrals are generally required, except in the case of the Hamiltonian equations of motion, where  $N$  integrals are sufficient. This also can be expressed in terms of the Liouville theorem, which states that any region of phase space must remain constant under any (integrable) Hamiltonian formalism. The phase space region can change its shape, but not its phase space volume. Therefore, for any conservative dynamical system, such as planetary motion or pendula that does not have an attracting point, the phase space must remain constant.

Another outcome of the Hamiltonian formulation, which started out as a formulation for regular motion, is the implication of the existence of irregular and chaotic trajectories. Poincare realized that nonintegrable, classical, three-body systems could lead to chaotic trajectories. Chaotic

behavior is due neither to a large number of degrees of freedom nor to any initial numerical imprecision. Chaotic behavior arises from a nonlinearity in the Hamiltonian equations with initially close trajectories that separate exponentially fast into a bounded region of phase space. Since initial conditions can only be measured with a finite accuracy and the errors propagate at an exponential rate, the long range behavior of these systems cannot be predicted.

The effects of perturbations in establishing regions of nonintegrability can be described for a weak perturbation using the KAM theorem. The KAM theorem, originally stated by Kolmogorov, and rigorously proven by Arnold and Moser, analyzed perturbative solutions to the classical many-body problem. The KAM theorem states that provided the perturbation is small, the perturbation is confined to an N-torus except for a negligible set of initial conditions which may lead to a wandering motion on the energy surface. This wandering motion is chaotic, implying a great sensitivity to initial conditions.

The N-tori, in this case, are known as KAM surfaces. When observed as plane sections they are often called KAM curves as illustrated in FIG. 2. These surfaces and curves may be slightly distorted (perturbed). That is, for a sufficiently small conservative Hamiltonian perturbation, most of the nonresonant invariant tori will not vanish, but will undergo a slight deformation, such that in the perturbed system phase space there are also invariant tori, filled by phase curves, which are conditionally periodic.



FIG. 2 illustrates a set of KAM invariant tori on the surface of which lie as elliptic integrable solutions. The nonintegrable solutions, irregular paths, which are hyperbolic in nature lie in between the invariant tori in so-called resonant zones, which are also sometimes referred to as stochastic zones.

The KAM results were extended through the results of J. Mather. KAM theory treats motions and related orbits that are very close to being well behaved and stable. Since KAM theory is basically a perturbation analysis, by its very nature the perturbation constant must be very small. Strong departures from the original operator through the perturbation parameter will invalidate the use of the original eigenfunctions used to generate the set of perturbed eigenfunctions. Mather's work analyzes unstable motions which are far from being well behaved. The perturbation can be relatively strong, and entirely new eigenfunctions (solutions) can be generated.

The practical importance of Mather's work for planetary orbit, escape, and capture is that the dynamics are applicable to those regions in phase space (i.e., Mather regions) associated with three- and four-body problems. Mather proved that for chaotic regions in lower (two) dimensions for any conservative Hamiltonian System, there exists or remains elliptical orbits which are unstable. In terms of NEO (near-Earth object) issues, KAM and Mather regions are important for describing both the orbital motions of comets, as well as for planning fuel conserving ballistic (flyby, rendezvous, and interception) trajectories to comets and other NEOs. The above discussion is a summary of the article by

John L. Remo, entitled "NEO Orbits and Nonlinear Dynamics: A Brief Overview and Interpretations," 822 Annals of the New York Academy of Sciences 176-194 (1997), incorporated herein by reference, including the references cited therein.

Since the first lunar missions in the 1960s, the moon has been the object of interest of both scientific research and potential commercial development. During the 1980s, several lunar missions were launched by national space agencies. Interest in the moon is increasing with the advent of the multi-national space station making it possible to stage lunar missions from low earth orbit. However, continued interest in the moon and the feasibility of a lunar base will depend, in part, on the ability to schedule frequent and economical lunar missions.

A typical lunar mission comprises the following steps. Initially, a spacecraft is launched from earth or low earth orbit with sufficient impulse per unit mass, or change in velocity, to place the spacecraft into an earth-to-moon orbit. Generally, this orbit is a substantially elliptic earth-relative orbit having an apogee selected to nearly match the radius of the moon's earth-relative orbit.

As the spacecraft approaches the moon, a change in velocity is provided to transfer the spacecraft from the earth-to-moon orbit to a moon-relative orbit. An additional change in velocity may then be provided to transfer the spacecraft from the moon-relative orbit to the moon's surface if a moon landing is planned. When a return trip to the earth is desired, another change in velocity is provided which is sufficient to insert the spacecraft into a

moon-to-earth orbit, for example, an orbit similar to the earth-to-moon orbit. Finally, as the spacecraft approaches the earth, a change in velocity is required to transfer the spacecraft from the moon-to-earth orbit to a low earth orbit or an earth return trajectory.

FIG. 3 is an illustration of an orbital system in accordance with a conventional lunar mission in a non-rotating coordinate system wherein the X-axis 10 and Y-axis 12 lay in the plane defined by the moon's earth-relative orbit 36, and the Z-axis 18 is normal thereto. In a typical lunar mission, a spacecraft is launched from earth 16 or low earth orbit 20, not necessarily circular, and provided with sufficient velocity to place the spacecraft into an earth-to-moon orbit 22.

Near the moon 14, a change in velocity is provided to reduce the spacecraft's moon-relative energy and transfer the spacecraft into a moon-relative orbit 24 which is not necessarily circular. An additional change in velocity is then provided to transfer the spacecraft from the moon-relative orbit 24 to the moon 14 by way of the moon landing trajectory 25. When an earth-return is desired, a change in velocity sufficient to place the spacecraft into a moon-to-earth orbit 26 is provided either directly from the moon's surface or through multiple impulses as in the descent. Finally, near the earth 16, a change in velocity is provided to reduce the spacecraft's earth-relative energy and return the spacecraft to low earth orbit 20 or to earth 16 via the earth-return trajectory 27.

FIG. 4 is an illustration of another conventional orbital system, described in U.S.

Patent 5,158,249 to Uphoff, incorporated herein by reference, including the references cited therein. The orbital system 28 comprises a plurality of earth-relative orbits, where transfer therebetween is accomplished by using the moon's gravitational field. The moon's gravitation field is used by targeting, through relatively small mid-orbit changes in velocity, for lunar swingby conditions which yield the desired orbit.

Although the earth-relative orbits in the orbital system 28 may be selected so that they all have the same Jacobian constant, thus indicating that the transfers therebetween can be achieved with no propellant-supplied change in velocity in the nominal case, relatively small propellant-supplied changes in velocity may be required.

Propellant-supplied changes in velocity may be required to correct for targeting errors at previous lunar swingbys, to choose between alternative orbits achievable at a given swingby, and to account for changes in Jacobian constant due to the eccentricity of the moon's earth-relative orbit 36.

In FIG. 4, a spacecraft is launched from earth 16 or low earth orbit into an earth-to-moon orbit 22. The earth-to-moon orbit 22 may comprise, for example, a near minimal energy earth-to-moon trajectory, for example, an orbit having an apogee distance that nearly matches the moon's earth-relative orbit 36 radius. The spacecraft encounters the moon's sphere of gravitational influence 30 and uses the moon's gravitational field to transfer to a first earth-relative orbit 32.

The first earth-relative orbit 32 comprises, for example, approximately one-half revolution of a substantially one lunar month near circular orbit

which has a semi-major axis and eccentricity substantially the same as the moon's earth-relative orbit 36, which is inclined approximately 46.3 degrees relative to the plane defined by the moon's earth-relative orbit 36, and which originates and terminates within the moon's sphere of influence 30. Because the first earth-relative orbit 32 and a typical near minimum energy earth-to-moon orbit 22 have the same Jacobian constant, the transfer can be accomplished by using the moon's gravitational field.

FIG. 5 is an illustration of another orbital system where, for example, satellites orbit the earth. A central station SC is situated at the center of a spherical triangle-shaped covering zone Z. Two geosynchronous satellites S-A and S-B have elliptical orbits with identical parameters. These parameters may be, for example, the following:

- apogee situated at about 50,543.4 km,
- perigee situated at about 21,028.6 km,
- meniscal axis of 42,164 km,
- inclination of 63 degrees,
- perigee argument 270,
- orbit excentricity 0.35.

Each satellite includes an antenna or antennae 11 and 12; each antenna is orientated towards the central station throughout the period when the satellite moves above the covering zone. The central station includes one connection station and one control station. FIG. 5 also shows a mobile unit M (which is situated inside zone Z, but which is shown above the latter for the sake of more clarity). This mobile unit is equipped with an

antenna 14 whose axis continuously points substantially towards the zenith.

In order to station such satellites, a large number of strategies are possible. One exemplary strategy is described with reference to FIG. 6. This strategy uses the ARIANE IV rocket and requires three pulses. At the time of launching, the satellite is accompanied by an ordinary geostationary satellite. The two satellites are placed on the standard transfer orbit of the ARIANE IV rocket, this orbit being situated within a quasi-equatorial plane (inclination of 7 degrees) with a perigee at 200 km, an apogee at 35,975 km and a perigee argument of 178 degrees. The orbit is marked as OST on FIG. 6.

Close to the perigee, a satellite rocket is ignited for a first pulse suitable for raising the apogee to 98,000 km, the orbit remaining within the same plane, orbit 01. This pulse may be broken down into two or three pulses. Close to the apogee of the orbit 01, a new pulse is sent to the satellite to change the plane of its orbit. The inclination of this plane is close to that of the plane of the definitive orbit, namely 63 degrees. This thrust is the largest and may be broken down into two or three thrusts. The orbit then becomes 02.

Finally, at an appropriate point of this orbit, a third thrust is sent to the satellite so as to provide it with a definitive orbit. If this strategy is satisfactory in certain respects, it nevertheless does constitute a drawback. In fact, it requires that the orbital plane be tilted when passing from the orbit 01 to the orbit 02, this resulting in a considerable consumption of propellant.

FIG. 7 is an illustration of another conventional lunar gravitational assistance transfer principle. In FIG. 7, the satellite is firstly transferred onto a standard orbit 01 situated inside a quasi-equatorial plane, which, in practice, is the orbit OST of FIG. 6, known as a Geostationary Transfer Orbit (GTO) orbit. At T1, the satellite is transferred onto a circumlunar orbit 02, still situated in the quasi-equatorial plane.

In practice, an extremely elliptic orbit is selected whose major axis is close to twice the Earth/Moon distance, namely about 768,800 km. The satellite penetrates into the sphere of influence SI of the moon and leaves this sphere on a trajectory 03 whose plane is highly inclined with respect to the equatorial plane. At T2, the satellite is injected onto the definitive orbit 04 inside the same plane as the orbit 03. The above described orbital system is described in detail in U.S. Patent 5,507,454 to Dulck, incorporated herein by reference, including the references cited therein.

Dulck attempts to minimize the thrusters needed, where the standard technique of lunar gravity assist is used. The satellite is first brought to a neighborhood of the moon by a Hohmann transfer. It then flies by the moon in just the right directions and velocities, where it is broken up into two or more maneuvers. This method works, but the size of this maneuver restricts the applications of the method to ellipses whose eccentricities are sufficiently large. This is because to have a savings with this large maneuver, the final maneuver needs to be sufficiently small.

I have determined that all of the above orbital systems and/or methods suffer from the requirement

of substantial fuel expenditure for maneuvers, and are therefore, not sufficiently efficient. I have also determined that the above methods focus on orbital systems that concentrate on the relationship between the earth and the moon, and do not consider possible effects and/or uses beyond this two-body problem.

Accordingly, it is desirable to provide an orbital system and/or method that furnishes efficient use of fuel or propellant. It is also desirable to provide an orbital system and/or method that it not substantially dependent on significant thrusting or propelling forces.

It is also desirable to provide an orbital system and/or method that considers the effects of lunar capture and/or earth capture as more than merely a two body problem. It is also desirable to provide an orbital system and/or method that may be implemented on a computer system that is either onboard the spacecraft or satellite, or located in a central controlling area.

It is also desirable to provide an orbital system and/or method that allows a spacecraft to make repeated close approaches to both the earth and moon. It is also desirable to provide an orbital system and/or method that is sustainable with relatively low propellant requirements, thereby providing an efficient method for cislunar travel.

It is also desirable to provide an orbital system and/or method that does not require large propellant supplied changes in velocity. It is also desirable to provide an orbital system and/or method that renders practical massive spacecraft components. It is also desirable to provide an



orbital system and/or method that may be used for manned and unmanned missions.

SUMMARY OF THE INVENTION

It is a feature and advantage of the present invention to provide an orbital system and/or method that furnishes efficient use of fuel or propellant.

It is another feature and advantage of the present invention to provide an orbital system and/or method that it not substantially dependent on significant thrusting or propelling forces.

It is another feature and advantage of the present invention to provide an orbital system and/or method that considers the effects of lunar capture and/or earth capture as more than merely a two body problem.

It is another feature and advantage of the present invention to provide an orbital system and/or method that may be implemented on a computer system that is either onboard the spacecraft or satellite, or located in a central controlling area.

It is another feature and advantage of the present invention to provide an orbital system and/or method that allows a spacecraft to make repeated close approaches to both the earth and moon.

It is another feature and advantage of the present invention to provide an orbital system and/or method that is sustainable with relatively low propellant requirements, thereby providing an efficient method for cislunar travel.

It is another feature and advantage of the present invention to provide an orbital system and/or method that does not require large propellant supplied changes in velocity.

It is another feature and advantage of the present invention to provide an orbital system and/or method that renders practical massive spacecraft components.

It is another feature and advantage of the present invention to provide an orbital system and/or method that may be used for manned and unmanned missions.

The present invention comprises a system and/or method for cislunar travel which substantially reduces the propellant requirements for lunar missions. The present invention also provides orbital systems useful for earth-to-moon and moon-to-earth travel, which do not directly utilize the moon's gravitational field to achieve orbital transfers and can be sustained with relatively low propellant requirements. The present invention further provides frequent earth return possibilities for equipment and personnel on the moon, or in a moon-relative orbit.

The present invention is based, in part, on my discovery that the conventional methods and/or orbital systems that concentrate or revolve around the relationship between the earth and the moon, and do not consider possible effects and/or uses beyond this two-body problem. More specifically, I have determined a new method and system that considers lunar travel and/or capture at least a three-body problem. This at least three-body problem includes the inter-relationship between the earth, moon and sun, including the inter-relationship of gravitational forces related thereto.

In accordance with one embodiment of the invention, a method generates an operational ballistic capture transfer for an object emanating

substantially at earth or earth orbit to arrive at the moon or moon orbit using a computer implemented process. The method includes the steps of entering parameters including velocity magnitude  $V_E$ , flight path angle  $\gamma_E$ , and implementing a forward targeting process by varying the velocity magnitude  $V_E$ , and the flight path angle  $\gamma_E$  for convergence of target variables at the moon. The target variables include radial distance,  $r_M$ , and inclination  $i_M$ . The method also includes the step of iterating the forward targeting process until sufficient convergence to obtain the operational ballistic capture transfer from the earth or the earth orbit to the moon or the moon orbit.

There has thus been outlined, rather broadly, the more important features of the invention in order that the detailed description thereof that follows may be better understood, and in order that the present contribution to the art may be better appreciated. There are, of course, additional features of the invention that will be described hereinafter and which will form the subject matter of the claims appended hereto.

In this respect, before explaining at least one embodiment of the invention in detail, it is to be understood that the invention is not limited in its application to the details of construction and to the arrangements of the components set forth in the following description or illustrated in the drawings. The invention is capable of other embodiments and of being practiced and carried out in various ways. Also, it is to be understood that the phraseology and terminology employed herein are

for the purpose of description and should not be regarded as limiting.

As such, those skilled in the art will appreciate that the conception, upon which this disclosure is based, may readily be utilized as a basis for the designing of other structures, methods and systems for carrying out the several purposes of the present invention. It is important, therefore, that the claims be regarded as including such equivalent constructions insofar as they do not depart from the spirit and scope of the present invention.

Further, the purpose of the foregoing abstract is to enable the U.S. Patent and Trademark Office and the public generally, and especially the scientists, engineers and practitioners in the art who are not familiar with patent or legal terms or phraseology, to determine quickly from a cursory inspection the nature and essence of the technical disclosure of the application. The abstract is neither intended to define the invention of the application, which is measured by the claims, nor is it intended to be limiting as to the scope of the invention in any way.

These together with other objects of the invention, along with the various features of novelty which characterize the invention, are pointed out with particularity in the claims annexed to and forming a part of this disclosure. For a better understanding of the invention, its operating advantages and the specific objects attained by its uses, reference should be had to the accompanying drawings and descriptive matter in which there is illustrated preferred embodiments of the invention.

BRIEF DESCRIPTION OF THE DRAWINGS

FIG. 1 depicts an integrable system with two degrees of freedom on a torus, and a closed orbit of a trajectory;

FIG. 2 illustrates a set of KAM invariant tori on the surface of which lie as elliptic integrable solutions;

FIG. 3 is an illustration of an orbital system in accordance with a conventional lunar mission in a non-rotating coordinate system;

FIG. 4 is an illustration of another conventional orbital system;

FIG. 5 is an illustration of another orbital system where, for example, satellites orbit the earth;

FIG. 6 is an illustration of another orbital system where, for example, satellites are placed in orbit about earth using the ARIANE IV rocket that requires three pulses;

FIG. 7 is an illustration of another conventional lunar gravitational assistance transfer principle;

FIG. 8 is an illustration of a forward integration method so the end state of the forward integration matches the beginning state determined by the backwards integration;

FIG. 9 is an illustration of an operational BCT determined by the forwards integration in accordance with the present invention;

FIG. 10 is another illustration of an operational BCT determined by the forwards integration in accordance with the present invention;

FIG. 11 is a conceptual illustration of a flowchart of the interaction between the Numerical Integrator and the Initial Condition Generator;

FIG. 11A is a detailed illustration of a flowchart of the interaction between the Numerical Integrator and the Initial Condition Generator;

FIG. 11B is another detailed illustration of a flowchart of the interaction between the Numerical Integrator and the Initial Condition Generator;

FIG. 12 is an illustration of a summary of various lunar missions;

FIG. 13 is an illustration of main central processing unit for implementing the computer processing in accordance with one embodiment of the present invention;

FIG. 14 is a block diagram of the internal hardware of the computer illustrated in FIG. 13; and

FIG. 15 is an illustration of an exemplary memory medium which can be used with disk drives illustrated in FIGs. 13-14.

#### Notations and Nomenclature

The detailed descriptions which follow may be presented in terms of program procedures executed on a computer or network of computers. These procedural descriptions and representations are the means used by those skilled in the art to most effectively convey the substance of their work to others skilled in the art.

A procedure is here, and generally, conceived to be a self-consistent sequence of steps leading to a desired result. These steps are those requiring physical manipulations of physical quantities. Usually, though not necessarily, these quantities take the form of electrical or magnetic signals

capable of being stored, transferred, combined, compared and otherwise manipulated. It proves convenient at times, principally for reasons of common usage, to refer to these signals as bits, values, elements, symbols, characters, terms, numbers, or the like. It should be noted, however, that all of these and similar terms are to be associated with the appropriate physical quantities and are merely convenient labels applied to these quantities.

Further, the manipulations performed are often referred to in terms, such as adding or comparing, which are commonly associated with mental operations performed by a human operator. No such capability of a human operator is necessary, or desirable in most cases, in any of the operations described herein which form part of the present invention; the operations are machine operations. Useful machines for performing the operation of the present invention include general purpose digital computers or similar devices.

The present invention also relates to apparatus for performing these operations. This apparatus may be specially constructed for the required purpose or it may comprise a general purpose computer as selectively activated or reconfigured by a computer program stored in the computer. The procedures presented herein are not inherently related to a particular computer or other apparatus. Various general purpose machines may be used with programs written in accordance with the teachings herein, or it may prove more convenient to construct more specialized apparatus to perform the required method steps. The required structure for a variety of

these machines will appear from the description given.

DESCRIPTION OF THE PREFERRED EMBODIMENTS OF THE INVENTION

When a rocket travels from the earth to the moon on a classical direct route taking only three days called a Hohmann transfer, it must fire its engines in order to slow down to achieve lunar orbit. Otherwise, the rocket will overfly the moon at about 1 km/s. A typical lunar mission comprises the following steps. Initially, a spacecraft is launched from earth or low earth orbit with sufficient impulse per unit mass, or change in velocity, to place the spacecraft into an earth-to-moon orbit. Generally, this orbit is a substantially elliptic earth-relative orbit having an apogee selected to nearly match the radius of the moon's earth-relative orbit.

As the spacecraft approaches the moon, a change in velocity is provided to transfer the spacecraft from the earth-to-moon orbit to a moon-relative orbit. An additional change in velocity may then be provided to transfer the spacecraft from the moon-relative orbit to the moon's surface if a moon landing is planned. When a return trip to the earth is desired, another change in velocity is provided which is sufficient to insert the spacecraft into a moon-to-earth orbit, for example, an orbit similar to the earth-to-moon orbit. Finally, as the spacecraft approaches the earth, a change in velocity is required to transfer the spacecraft from the moon-to-earth orbit to a low earth orbit or an earth return trajectory.



The propellant required at each step above depends on the mass of the spacecraft and the change of velocity required to effect the orbital transfer. The change in velocity at each step is generally provided by burning propellant. A mass of propellant is thereby expelled from the spacecraft at a large spacecraft-relative velocity, and the remaining spacecraft mass changes velocity reactively. As a practical matter, because the orbital transfers in prior art lunar missions are achieved by burning propellant, the number and magnitude of orbital transfers which can be performed in a lunar mission are highly sensitive to the mass of the spacecraft.

It had been always assumed that it was not realistically possible to be captured at the moon without requiring slowing down using the engines. The present invention comprises a system and/or method for cislunar travel which substantially reduces the propellant requirements for lunar missions. The present invention also provides orbital systems useful for earth-to-moon and moon-to-earth travel, which do not directly utilize the moon's gravitational field to achieve orbital transfers and can be sustained with relatively low propellant requirements. The present invention further provides frequent earth return possibilities for equipment and personnel on the moon, or in a moon-relative orbit.

When a spacecraft arrives at the Moon from a Hohmann transfer, it has a hyperbolic excess velocity of approximately 1 km/s. Thus, to be captured into an elliptic lunar orbit, the spacecraft, S/C, must be slowed by the use of the propulsion system. The amount of propellant to do

this can be significant and, moreover, there is a relatively short period of time for the braking maneuver to accomplish the lunar capture. The ability to achieve capture, that is for a S/C to have an elliptic orbital state with respect to the Moon at lunar periapsis, without the use of braking rockets is called *ballistic capture*.

Belbruno first found a way to do this in 1986 for an electric propulsion spacecraft mission study called LGAS (Lunar Get Away Special), Belbruno, E., *Lunar Capture Orbits, a Method of Constructing Earth-Moon Trajectories and the Lunar GAS Mission*, AIAA Paper no. 97-1054, Proceedings of AIAA/DGLR/JSASS Inter. Elec. Propl. Conf., May 1987, incorporated herein by reference including the references cited therein. This was accomplished realizing that in order for ballistic capture to occur, the S/C must arrive at the Moon in a weakly captured state. That is, the S/C must have a velocity at the desired capture radius where it is balancing between capture and escape. A region can be estimated about the Moon where this occurs, and it is called the *Weak Stability Boundary (WSB)* or the *Fuzzy Boundary*, Belbruno, E., *Lunar Capture Orbits, a Method of Constructing Earth-Moon Trajectories and the Lunar GAS Mission*, AIAA Paper no. 97-1054, Proceedings of AIAA/DGLR/JSASS Inter. Elec. Propl. Conf., May 1987; Belbruno, E., *Example of the Nonlinear Dynamics of Ballistic Capture and Escape in the Earth-Moon System*, AIAA Paper No. 90-2896, Proceedings of the Annual AIAA Astrodynamics Conference, August 1990; Belbruno, E.; Miller, J., *Sun-Perturbed Earth-to-Moon Transfers with Ballistic Capture*, *Journal of Guidance, Control, and dynamics*, V.16, No. 4, July-August 1993. pp 770-775;

Belbruno, E., *Ballistic Lunar Capture Transfers using the Fuzzy Boundary and Solar Perturbations: A Survey*, Journal of the British Interplanetary Society, v. 47, Jan. 1994, pp 73-80; Belbruno, E., *The Dynamical Mechanism of Ballistic Lunar Capture Transfers in The Four-Body Problem From The Perspective of Invariant Manifolds and Hill's Regions*, Centre De Recreca Matematica (CRM) Preprint n. 270, December 1994, all of which are hereby incorporated by reference including the references cited therein.

Once the WSB is estimated, the problem of ballistic capture reduces to the problem of reaching this region (i.e. arrive at the Moon at the desired altitude with the correct velocity). Because the WSB lies between capture and escape, the S/C does not have a well defined central body - the Earth or the Moon. Thus its motion is quite sensitive. Because of this, it seemed at the time that a forward Newton targeting search to this region from near the Earth would not be successful. This indeed seemed to be true.

It was solved by the *backwards method*, suggested by D. Byrnes in 1986. This has been used to find precision BCT's for actual missions and mission studies ever since starting with LGAS, then Hiten in 1990, Lunar Observer in 1990, the planned Lunar-A, and, until late 1996, Blue Moon. See, e.g., Yamakawa, H.; Kawaguchi, J.; Ishii, N.; Matsuo, H., *On Earth-Moon Transfer Trajectory with Gravitational Capture*, Proceedings AAS/AIAA Astrodynamics Sp. Conf., Paper No. AAS 93-633, August 1993; Kawaguchi, J.; Yamakowa, H.; Uesugi, T.; Matsuo, H., *On Making Use of Lunar and Solar Gravity Assists in Lunar-A, Planet-B Missions*, Acta.

Astr., V. 35, pp 633-642, 1995; Cook, R.A.; Sergeyevsky, A.B.; Belbruno, E.; Sweetser, T.H.; *Return to the Moon; The Lunar Observer Mission*, Proceedings AIAA/AAS Astrodynamics Conf., Paper No. 90-288, August 1990; Sweetser, T., *Estimate of the Global Minimum DV Needed for Earth-Moon Transfers*, Proceedings AAS/AIAA Spaceflights Mechanics Meeting, Paper No. 91-101, February 1991; Humble, R.W., *Blue Moon; A Small Satellite Mission to the Moon*, Proceedings Int.Symp. on Small Satellite Systems and Services, Annecy, France, June 1996, all of which hereby incorporated by reference herein including all the references cited therein, and references previously incorporated herein.

The backwards method starts at the desired capture position  $y$  with respect to the WSB at the Moon where the osculating eccentricity  $e_M < 1$ . Using this as the initial position, one integrates in backwards time. Because of the sensitivity of the region, a negligible increase in velocity at  $y$  will cause the S/C to escape the Moon in backwards time. It will have a periapsis at a point  $x$  with respect to the Earth where the integration is stopped. In general, this point will be different from the starting point  $x_0$  for the S/C.

The BCT is then found by performing a forward integration from  $x_0$  to  $x$ . The path from  $x$  to the capture point  $y$  is already determined. The gain made in the  $\Delta V$  savings due to ballistic capture is offset by the mismatch in velocity at  $x$  requiring a maneuver  $\Delta V_M$ . This is abstractly shown in FIG. 8. Variation of different parameters are used to try and reduce the  $\Delta V_M$ .

In the case of LGAS,  $x_0$  is at 200 km altitude from the Earth, and  $x$  is at 100,000 km. The point  $y$

is 30,000 km over the north lunar pole. The S/C takes about one year to gradually spiral out to  $x$  using its low thrust ion engines, where  $\Delta V_M$  is zero. The portion of the transfer from  $x$  to  $y$  in the WSB where  $e_M = 0$  takes 14 days.

The method was used again by Belbruno, assisted by J. Miller in 1990 for the Hiten mission of Japan. See previous references incorporated by reference herein. Hiten did not have sufficient propellant to be captured at the Moon by the Hohmann transfer, so the BCT was the only option. It was in elliptic Earth orbit where the periapsis radial distance was 8,900 km at  $x_0$ . The capture position  $y$  in the WSB was 100 km over the north lunar pole, where the osculating value of the eccentricity  $e_M = .94$ .

Under the influence of solar perturbations, backwards integration from  $y$  pulled the S/C out to an Earth periapsis at  $x$ , 1.2 million km from the Earth. A tiny  $\Delta V$  of 14 m/s at  $x_0$  was sufficient to allow Hiten to move to  $x$  where  $\Delta V_M = 30$  m/s. The time of flight was 150 days. This BCT was used in 1991, and Hiten arrived at the Moon on October 2 of that year.

This type of BCT used by Hiten can be used for general lunar missions where injection conditions at the Earth and capture conditions at the Moon are arbitrary. To make it more applicable to general missions, the backwards approach would have to be generalized and made to be more flexible. Joint work from 1992-1993 discovered a way to adapt the backwards approach for general missions, including finding launch periods. Tandon, S., *Lunar Orbit Transfers using Weak Stability Boundary Theory*, McDonnell Douglas Internal Report (Huntington Beach), March 1993. However, it is unwieldy and

seemingly difficult to automate. This is because one has to generally satisfy six orbital elements at the Earth.

We focused on BCT's with no maneuvers at  $x$ . By carefully adjusting the lunar capture WSB conditions at  $y$ , it is not difficult to adjust the backwards integration so that the trajectory comes back to the Earth at any desired altitude  $r_E$ , at  $x_0$ . In fact, variation of  $e_M$  in the WSB in the third and higher decimal places is sufficient for this. The time of flight is only 80 days. However, when doing this, one has no control over the inclination,  $i_E$ . If one starts at  $x_0$  and then tries to walk the inclination over to the desired value, it was seen immediately that it did not seem to be possible. Even a change in  $i_E$  in the thousandths place causes the forward targeting algorithm to diverge when targeting back to the WSB conditions.

This can be solved by a more involved backwards integration where several lunar variables,  $\Omega_M$ ,  $\omega_M$ ,  $e_M$ , have to be varied to achieve both the correct of  $r_E$ ,  $i_E$ . However, the variables  $\Omega_E$ ,  $\omega_E$  remain to be satisfied. The procedure to do this is complicated and involves the comparison of many contour plots of the Earth elements, and backwards integrations. Eventually they can be satisfied. However, the approach is time intensive.

I have found, however, a set of variables with respect to the earth which give rise to a very flexible and well behaved forward targeting to ballistic capture lunar conditions using two variables at the Earth to vary, where the variables do not change in the process. These variables are

1. velocity magnitude,
2. flight path angle.

I have also discovered a way to efficiently find BCT's in a relatively simple forward targeting method from  $x_0$  to  $y$  which is fairly robust. This forward method turns out to be 2X2. That is, two variables at the Earth are varied in a Newton's targeting algorithm to achieve WSB conditions at the Moon using two lunar elements. In carrying it out, most of the variables of interest at the Earth decouple in the process. This gives control on  $r_E$ ,  $i_E$ ,  $\Omega_E$ . Several examples are given below.

In order to have a robust search from the Earth at a given point  $x_0$ , to WSB conditions at the Moon at  $y$ , the algorithm should be able to converge down to a BCT with large initial errors in achieving the desired lunar conditions. The independent variables being varied at  $x_0$  to achieve these lunar conditions should be decoupled from as many angular Earth elements as possible which include  $i_E$ ,  $\Omega_E$ ,  $\omega_E$ . It is assumed that search is done with a time from periapsis,  $T_E$ , approximately equal to zero. All three of these angular variables can be quite constrained depending on the launch vehicle. For example, for an Arienne IV,  $i_E = 7^\circ$ ,  $\Omega_E \approx 8^\circ$  (West),  $\omega_E = 178^\circ$ .

The target variables at the Moon of main interest to satisfy are the radial distance,  $r_M$ , and the inclination,  $i_M$ . For the Blue Moon mission, we assume  $r_M = 2238$  km, representing an altitude of 500km, and  $i_M = 90^\circ$ . It turns out that if the S/C falls towards the Moon from approximately 1 to 1.5 million km from the Earth near an Earth apoapsis in approximately the ecliptic, then it falls into the lunar WSB provided the Earth-Moon-Sun geometry is correct.

The coordinate system at the Earth required for the targeting algorithm at  $x_0$  is spherical coordinates. They are given by  $r_E$ , longitude,  $\alpha_E$ , latitude,  $\delta_E$ , velocity magnitude,  $V_E$ , flight path angle,  $\gamma_E$ , flight path azimuth,  $\sigma_E$ . The flight path azimuth is the angle from the positive z-axis of the local cartesian coordinate system to the velocity vector  $V_E = (x, y, z)$ . More exactly,

$$\sigma_E = \cos^{-1}(z/V_E)$$

We fix  $r_E = 6563.94$  km corresponding to an altitude of 186 km for the Blue Moon. The targeting algorithm is given by varying  $V_E$ ,  $\gamma_E$  to try to achieve  $r_M$ ,  $i_M$ . A standard second order Newton algorithm is used. Symbolically,

$$V_E, \gamma_E \rightarrow r_M, i_M$$

It is checked that  $i_E$ ,  $\Omega_E$  are independent of  $V_E$ ,  $\gamma_E$ . Thus, the 2X2 search defined by (1) does not alter  $i_E$ ,  $\Omega_E$ . As a result, once (1) converges to a BCT, for a given  $i_E$ ,  $\Omega_E$ , these can be changed and (1) can be rerun. This is done by taking the converged values of  $V_E$ ,  $\gamma_E$  together with the other four fixed spherical variables, and transforming them to classical elements. In the classical elements,  $i_E$ ,  $\Omega_E$  are changed as desired.

The classical state is then transformed back to spherical coordinates. The new spherical state will still have the same converged values of  $V_E$ ,  $\gamma_E$  (since  $V_E$ ,  $\gamma_E$  are independent of  $i_E$ ,  $\Omega_E$ ), however,  $\alpha_E$ ,  $\delta_E$ ,  $\sigma_E$  will be changed. If this is not too much, the (1) should converge. In this way  $i_E$ ,  $\Omega_E$  can be systematically walked over to their desired values by rerunning (1) a finite number of times.



The remaining variable that there has been no control over is  $\omega$ . There are several approaches that could be used to adjust this variable. These range from variation of the Earth injection date (I/D), to the use of contours, or the inclusion of a maneuver. It is, in general, a good idea to construct contours of the time of flight ( $T_f$ ),  $i_E$ ,  $\Omega_E$ ,  $\omega_E$  by variation of  $\Omega_M$ ,  $\omega_M$ . The data for these contours is generated by systematically varying  $\Omega_M$ ,  $\omega_M$  and for each different variation, adjusting  $e_M$  so that the trajectory in backward time returns to Earth at the same radial distance. That is, by 1X1 Newton targeting  $e_M \rightarrow r_E$ .

For each value of  $(\Omega_M, \omega_M)$ , the value of  $(T_f, i_E, \Omega_E, \omega_E)$  is recorded. These arrays can be used in any number of contour programs. The contours of these variables can be useful in determining regions of the parameter space, including I/D, where the desired values of  $i_E$ ,  $\Omega_E$ ,  $\omega_E$  can be found.

It is noted that to start the procedure, a good guess for  $V_E$ ,  $\gamma_E$  and the other spherical variables needs to be found so (1) converges. There are many ways to do this. One thing to do is to go to classical elements, and choose  $a_E$ ,  $e_E$  so that the S/C is on an ellipse of an apoapsis between 1 and 1.5 million km, and that the periapsis distance is at the desired altitude. For example, realistic values are  $a = 657,666$  km,  $e = .9900$ . The other variables can be manually tested to see if convergence of (1) results.

The robustness of (1) is illustrated in Table 1 which represents a change of  $i_E$  by two degrees from a previously converged case with  $i_E = 21.56^\circ$  (EME of Date) to  $19.56^\circ$ . Throughout the search,  $\Omega_E = 36.51^\circ$ . Although there is a huge miss distance of 252,243 km

on the first iteration, convergence still results. The resulting time of flight on the converged iteration was 93 days, 5 hours, 13 minutes.

Table 1. Targeting Iterations

Iteration	$V_E$	$Y_E$	$r_M$	$i_M$
1 1.79 .21	10.992708088	1.310755264	252243.45	157.23
2 .21	10.992996382	1.310755164	59489.90	54.70
3 .32	10.992972418	1.310755175	36675.56	56.85
4 .62	10.992950388	1.310755214	11753.77	54.34
5 .80	10.992928540	1.310604119	6286.67	67.74
10 .93	10.992752082	0.906403936	2237.74	89.93
11 .93	10.992751828	0.905723383	2241.06	90.03
12 .93	10.992751819	0.905724637	2238.00	90.00

This section is concluded with the documentation of a BCT for Blue Moon which is designed for an Ariane IV launch vehicle:

1. **Earth Injection**

T: July 16, 1997 06:16:55 (ET)  
 $r_E = 6563.94$  km  
 $V_E = 10.99$  km/s  
 $i_E = 7^\circ$

## 2. Apoapsis

T: August 22, 1997 11:48:08  
 $r_E = 1,370,923$  km  
 $V_E = .215$  km/s

## 3. Lunar Capture

T: October 19, 1997 06:52:47  
 $r_M = 2238.00$  km  
 $V(\text{Moon}) = 2.08$  km/s  
 $a_M = 84,217.12$  km  
 $e_M = .97$   
 $i_M = 90^\circ$

This BCT is plotted in FIG. 9.

FIG. 10 is another illustration of an operational BCT determined by the forwards integration in accordance with the present invention. In FIG. 10, the ballistic lunar capture trajectory is illustrated. Leg 1 of the trajectory begins at the earth, substantially near the earth or at an orbit around the earth and extends until the earth-sun weak stability boundary. Maneuver 1 is associated with leg 1, and may be, for example, 11 meters per second (m/s) at the earth-sun WSB. Alternatively, the thrust may be designed such that at the earth-sun WSB, the object in the trajectory is going faster than 11 m/s or even arrives at the earth-sun WSB at zero m/s.

The object passes the moon area approximately three day later along leg 1. In addition, the object arrives at the end of leg 1 approximately one and a half months later. At the earth-sun WSB, a second maneuver is performed for leg 2 of the journey which takes the object from the earth-sun WSB to lunar capture around the moon. This time period takes approximately another three months for leg 2.

Whereas the backwards integration approach took one month of daily full time work to find an operational BCT, this new procedure with forward targeting, takes a few minutes on a computer. It can easily be automated to walk  $i$ ,  $\Omega$ ,  $\omega$  over to their desired values. However, this is easily done manually. It is noted that the targeting procedure is only a 2 X 2. That is, two control variables and two target variables. Given the nature of the BCT, this is an elegant procedure.

The software required to do this is

1. Numerical integrator with targeting capability,
2. Initial condition generator.

See FIG. 11 for a flowchart of the interaction between the Numerical Integrator 102 and the Initial Condition Generator IGUESS 100 in accordance with the present invention.

The integrator is extremely accurate and is a standard 10th order, or other standard integrator. The targeter is a standard second order Newton's method. This integrator models the solar system as accurately as is scientifically available, and uses a planetary ephemeris. This accuracy is necessary since this procedure produces operational transfers that are suitable for real missions and flight.

The trajectories generated by the integrator are found to be in negligible error with the actual paths of the spacecraft. The integrator-targeter is in stand-alone source code and is written in FORTRAN. This integrator-targeter software is included in U.S. provisional application serial number 60/036,864, incorporated herein by reference. The initial condition generator produces a good initial guess in the desired targeting variables in spherical coordinates, and allows incremental change in  $i$ ,  $\Omega$ ,  $\omega$ . This is needed so that the targeter can converge.

The integrator-targeter requires a precise planetary ephemeris of the motions of the planets. It is the standard data file for the planets produced at JPL and is called DE403, incorporated herein by reference. It is used throughout the world for astronomers and in aerospace.

FIG. 11A is a detailed illustration of a flowchart of the interaction between the Numerical Integrator and the Initial Condition Generator. As illustrated in FIG. 11A, the procedure of the present invention uses two different types of variables in the targeted search, using a second order Newton's method (NM) 104 for the targeter, and a 10th order integrator (I) 106 to numerically propagate an orbit (or trajectory) from the earth to the moon. A 2x2 search is used for the targeter (although other dimensional searches may also be used), i.e., two variables (out of 6) are varied at the earth, and target to two at the moon (out of six).

At the moon, two parameters are enough. They are  $i_M, r_M$ . For the targeter, a special set of 6 variables are preferably used, called spherical coordinates, and two of these are selected to vary to reach  $i_M, r_M$  (of course, the present invention also includes the use of

different variables that are derivable from the present invention). The six variables are  $r_E, \alpha_E, s_E, v_E, \gamma_E, \sigma_E$ . The two that are actually varied are  $v_E, \gamma_E$ . With a good guess for  $v_E, \sigma_E$  the targeter converges. IGESS 100 determines a good initial guess for  $v_E, \gamma_E$ .

The targeter incorporates the integrator as it operates. It needs to use integrator I multiple times as it operates. Its goal is to iteratively determine the accurate value of  $v_E, \gamma_E = v_E^*, \gamma_E^*$  so that a BCT reaches the moon to the desired values of  $r_M, i_M$ . Only one guess from IGESS is required at the very start of the targeting process.

FIG. 11B is another detailed illustration of a flowchart of the interaction between the Numerical Integrator and the Initial Condition Generator. The BCT just produced goes from the Earth at a given orbital state to the moon where  $r_M, i_M$  are achieved to their desired values. In the process described in FIG. 11B, only  $v_E, \gamma_E$  are varied, and the other four variables  $r_E, \alpha_E, s_E, \sigma_E$  are fixed. Our six variables determined are therefore  $r_E, \alpha_E, s_E, v_E^*, \gamma_E^*, \sigma_E$ .

To make an operational BCT, 6 orbital parameters making what's called an orbital state, are required at the earth. They are given ahead of time by a mission, and must all be satisfied. The variables usually need to satisfy another set of variables, related to the above ones, but different. They are called classical elements, and are  $\alpha_E, e_E, i_E, \Omega_E, W_E, T_E$ . The above converged state,  $S = r_E, \alpha_E, s_E, v_E^*, \gamma_E^*, \sigma_E$  will yield a specific set of classical variables  $C = \alpha_E, e_E, i_E, \Omega_E, W_E, T_E$ .

In general, the values of the classical variables will not be what the mission may require. A mission will want a specific  $i_E = i_E^*, \Omega_E, W_E^*$ . These are usually trick to nail down. The others,  $\alpha_E, e_E, T_E,$

are easy to determine, and not really an issue. If, as  $v_E, \gamma_E$  varied in NM,  $i_E, \Omega_E$  varied, that would be a complication. However,  $i_E, \Omega_E$  are independent of  $v_E, \gamma_E$ , so they remain fixed as NM converges. Thus, after NM converges,  $i_E, \Omega_E$  can be updated to a slightly different value, and NM should converge again. By iteratively doing this,  $i_E, \Omega_E$  can be gradually walked over to their desired values, after applying FIG. 11A many times. The best way to vary  $i_E, \Omega_E$  can be guided by knowing the contour space of C, which can be determined by standard contour programs (e.g., CONT commercial program). The final variable left is  $W_E$  which does vary as NM operates. However, it varies little and can also be walked over to its desired value:

In summary, the process described in FIG. 11B is reiterated or reapplied until  $i_E, \Omega_E$  are walked over to desired values. A standard contour program is used to assist in this. Finally, walk over  $W_E$  to its desired value by reapplying the process described in FIG. 11B a sufficient number of times.

FIG. 13 is an illustration of main central processing unit 218 for implementing the computer processing in accordance with one embodiment of the present invention. In FIG. 13, computer system 218 includes central processing unit 234 having disk drives 236 and 238. Disk drive indications 236 and 238 are merely symbolic of the number of disk drives which might be accommodated in this computer system. Typically, these would include a floppy disk drive such as 236, a hard disk drive (not shown either internally or externally) and a CD ROM indicated by slot 238. The number and type of drives varies, typically with different computer configurations. The computer includes display 240 upon which information

is displayed. A keyboard 242 and a mouse 244 are typically also available as input devices via a standard interface. FIG. 14 is a block diagram of the internal hardware of the computer 218 illustrated in FIG. 13. As illustrated in FIG. 14, data bus 248 serves as the main information highway interconnecting the other components of the computer system. Central processing units (CPU) 250 is the central processing unit of the system performing calculations and logic operations required to execute a program. Read-only memory 252 and random access memory 254 constitute the main memory of the computer, and may be used to store the simulation data.

Disk controller 256 interfaces one or more disk drives to the system bus 248. These disk drives may be floppy disk drives such as 262, internal or external hard drives such as 260, or CD ROM or DVD (digital video disks) drives such as 258. A display interface 264 interfaces with display 240 and permits information from the bus 248 to be displayed on the display 240. Communications with the external devices can occur on communications port 266.

FIG. 15 is an illustration of an exemplary memory medium which can be used with disk drives such as 262 in FIG. 14 or 236 in FIG. 13. Typically, memory media such as a floppy disk, or a CD ROM, or a digital video disk will contain, inter alia, the program information for controlling the computer to enable the computer to perform the testing and development functions in accordance with the computer system described herein.

Although the processing system is illustrated having a single processor, a single hard disk drive and a single local memory, the processing system may suitably be equipped with any multitude or combination of processors or storage devices. The processing



system may, in point of fact, be replaced by, or combined with, any suitable processing system operative in accordance with the principles of the present invention, including sophisticated calculators, and hand-held, laptop/notebook, mini, mainframe and super computers, as well as processing system network combinations of the same.

Conventional processing system architecture is more fully discussed in Computer Organization and Architecture, by William Stallings, MacMillan Publishing Co. (3rd ed. 1993); conventional processing system network design is more fully discussed in Data Network Design, by Darren L. Spohn, McGraw-Hill, Inc. (1993), and conventional data communications is more fully discussed in Data Communications Principles, by R.D. Gitlin, J.F. Hayes and S.B. Weinstein, Plenum Press (1992) and in The Irwin Handbook of Telecommunications, by James Harry Green, Irwin Professional Publishing (2nd ed. 1992). Each of the foregoing publications is incorporated herein by reference.

In alternate preferred embodiments, the above-identified processor, and in particular microprocessing circuit, may be replaced by or combined with any other suitable processing circuits, including programmable logic devices, such as PALs (programmable array logic) and PLAs (programmable logic arrays). DSPs (digital signal processors), FPGAs (field programmable gate arrays), ASICs (application specific integrated circuits), VLSIs (very large scale integrated circuits) or the like.

It is remarked that the starting position from the earth for a BCT computed with this procedure can be at any altitude, suitable for any launch vehicle, the international space station Alpha, under

development, the revolutionary single stage to orbit vehicle called Venture Star using a new type of rocket engine under development by Lockheed. Utilization of the FB region yields other low energy transfers to asteroids, Mars, and from these locations, using so called resonance hopping.

In summary, this forward targeting procedure to produce operational BCT's is substantially easier to use and faster than the backwards approach. It is a 2 X 2 procedure and makes the computation of BCT's a straight forward process, and it is robust. The BCT's can be computed for any starting positions with respect to the earth or arrival conditions at the moon.

Recent planned missions for the remainder of this decade show that the BCT is becoming the route of choice. Japan plans to use it again in 1998 on the so called Lunar-A mission, and the US Air Force Academy plans to use it in 1998-1999 for the so called Blue Moon mission. In fact, components of the Blue Moon mission will be tested in space on a launch of an Atlas rocket on October 21, 1997 from Cape Canaveral. Of the five lunar missions from 1991-1999, three are using the BCT.

The future for lunar development looks very promising. In the next 10 years, there is projected to be billions of dollars spent on lunar missions. Use of the BCT can cut this cost in half, or equivalently, potentially be the transfer of choice and be responsible for billions of dollars in lunar missions.

There have been three very important developments which imply that from 1999 on, there should be regular and frequent lunar missions, a small lunar base in

about 10 years and then large scale commercial projects.

1. In July 1996, Lockheed was awarded a 1 billion dollar contract to develop a 1/3 scale version of a single stage to orbit rocket using the aerospike engine. This is the so called X-33 rocket. It will revolutionize space travel and make flying into space as routine as flying a jet. The smaller version is to be ready in 1998, and the full scale version in 2002. It is called the Venture Star, and NASA has said it plans to replace its shuttle fleet with them. Smaller versions will no doubt be commercially available and open up space for the public.

2. In November 1996, water in large easily accessible quantities was discovered on the moon in the south polar regions. This means that development of the moon is very likely. This is because water gives a self-sustaining capability.

3. The international space station Alpha starts to go up in Fall of 1997, and is to be completed in 2001. This will give a large scale permanent presence in space, and the station can be used as a launching platform.

There are already two lunar missions being planned for 2000, 2001 to investigate the lunar water further, and a lot of talk about a small lunar base. After the Venture Star gets rolling, commercial lunar development is sure to follow with hotels, etc. In fact, Mitsubishi, and other large Japanese corporations have discussed large hotel complexes. See FIG. 12 for a summary of the various lunar missions.

The many features and advantages of the invention are apparent from the detailed specification, and thus, it is intended by the appended claims to cover

all such features and advantages of the invention which fall within the true spirit and scope of the invention. Further, since numerous modifications and variations will readily occur to those skilled in the art, it is not desired to limit the invention to the exact construction and operation illustrated and described, and accordingly, all suitable modifications and equivalents may be resorted to, falling within the scope of the invention.

What is claimed is:

1. A method of generating operational ballistic capture transfer for an object emanating substantially at earth or earth orbit to arrive at the moon or moon orbit using a computer implemented process, comprising the steps of:

(a) entering parameters including velocity magnitude  $V_E$ , flight path angle  $\gamma_E$  for said method of generating operational ballistic capture transfer;

(b) implementing a forward targeting process by varying the velocity magnitude  $V_E$ , and the flight path angle  $\gamma_E$  for convergence of target variables at the moon, the target variables including radial distance,  $r_M$ , and inclination  $i_M$ ; and

(c) iterating step (b) until sufficient convergence to obtain the operational ballistic capture transfer from the earth or the earth orbit to the moon or the moon orbit.

2. A method of generating operational ballistic capture transfer for an object emanating substantially at earth or earth orbit to arrive at the moon or moon orbit according to claim 1, wherein the forward targeting process is a second order Newton algorithm.

3. A method of generating operational ballistic capture transfer for an object emanating substantially at earth or earth orbit to arrive at the moon or moon orbit according to claim 1, wherein the second order Newton algorithm utilizes two control variables including the velocity magnitude  $V_E$ , and the flight path angle  $\gamma_E$ , and two target variables including the radial distance,  $r_M$ , and the inclination  $i_M$ .

4. A method of generating operational ballistic capture transfer for an object emanating substantially at earth or earth orbit to arrive at the moon or moon orbit according to claim 1, wherein the second order Newton algorithm utilizes two control variables including the velocity magnitude  $V_E$ , and the flight path angle  $\gamma_E$  that are varied to achieve weak stability boundary (WSB) conditions at the moon or the moon orbit using the two target variables including the radial distance,  $r_M$ , and the inclination  $i_M$ .

5. A method of generating operational ballistic capture transfer for an object emanating substantially at earth or earth orbit to arrive at the moon or moon orbit according to claim 1, wherein the velocity magnitude  $V_E$ , and the flight path angle  $\gamma_E$  are decoupled from the moon or the moon orbit in the method of generating operational ballistic capture transfer.

6. A method of generating operational ballistic capture transfer for an object emanating substantially at earth or earth orbit to arrive at the moon or moon orbit according to claim 5, wherein the decoupling of the velocity magnitude  $V_E$ , and the flight path angle  $\gamma_E$  provides control of radial distance  $r_E$ , inclination  $i_E$ , and node  $\Omega_E$  at the earth or the earth orbit.

7. A method of generating operational ballistic capture transfer for an object emanating substantially at earth or earth orbit to arrive at the moon or moon orbit according to claim 1, wherein the velocity magnitude  $V_E$ , and the flight path angle  $\gamma_E$  are decoupled from angular earth elements including inclination  $i_E$ , ascending node relative to earth  $\Omega_E$ , and argument of periapsis relative to earth  $\omega_E$ , in the method of generating operational ballistic capture transfer.

8. A method of generating operational ballistic capture transfer for an object emanating substantially at earth or earth orbit to arrive at the moon or moon orbit according to claim 1, wherein the  $\omega_E$  is adjusted via at least one of variation of earth injection date (I/D), use of contours, and inclusion of a maneuver.

9. A method of generating operational ballistic capture transfer for an object emanating substantially at earth or earth orbit to arrive at the moon or moon orbit according to claim 1, further comprising the steps of:

(d) transforming converged values of  $V_E$ ,  $\gamma_E$  into classical elements;

(e) transforming the classical elements to spherical coordinates, wherein the spherical coordinates include the converged values of  $V_E$ ,  $\gamma_E$ , and longitude  $\alpha_E$ , latitude  $\delta_E$ , flight path azimuth/angle with vertical  $\sigma_E$  are changed.

10. A method of generating operational ballistic capture transfer for an object emanating substantially at earth or earth orbit to arrive at the moon or moon orbit according to claim 1, wherein said entering step (a) comprises the step of entering the parameters including the velocity magnitude  $V_E$ , the flight path angle  $\gamma_E$  using contours to facilitate initial selection of the parameters for said method of generating operational ballistic capture transfer.

11. A method of generating operational ballistic capture transfer for an object emanating substantially at earth or earth orbit to arrive at the moon or moon orbit according to claim 1, wherein said entering step (a) comprises the step of entering the parameters using an initial guess in spherical, flightpath coordinates to facilitate initial selection of the parameters for said method of generating operational ballistic capture transfer.

12. A method of generating operational ballistic capture transfer for an object emanating substantially



at earth or earth orbit to arrive at the moon or moon orbit according to claim 1, wherein said implementing step (b) comprises the step of implementing the forward targeting process utilizing a precise planetary ephemeris of the motions of planets.

13. A method of traveling from substantially at earth or earth orbit to the moon or moon orbit in a space vehicle or rocket using an operational ballistic capture transfer, comprising the steps of:

(a) generating the operational ballistic capture transfer by implementing a forward targeting process by varying velocity magnitude  $V_E$ , and flight path angle  $\gamma_E$  until convergence of target variables at the moon, the target variables including radial distance,  $r_M$ , and inclination  $i_M$ ; and

(b) traveling from substantially at the earth or the earth orbit to the moon or the moon orbit using the operational ballistic capture transfer by the space vehicle or the rocket.

14. A method of traveling from substantially at earth or earth orbit to the moon or moon orbit in a space vehicle or rocket using an operational ballistic capture transfer according to claim 13, wherein said traveling step (b) further comprises the step of traveling from substantially at the earth or the earth orbit to the moon or the moon orbit using the operational ballistic capture transfer dynamically generated in the space vehicle or the rocket.

15. A method of traveling from substantially at earth or earth orbit to the moon or moon orbit in a space vehicle or rocket using an operational ballistic capture transfer according to claim 13, wherein said

traveling step (b) further comprises the step of traveling from substantially at the earth or the earth orbit to the moon or the moon orbit using the operational ballistic capture transfer dynamically generated in a central controller remote from the space vehicle or the rocket.

16. A navigational system for generating operational ballistic capture transfer for an object emanating substantially at earth or earth orbit to arrive at the moon or moon orbit using a computer,

wherein the computer implements the functions of:

(a) entering parameters including velocity magnitude  $V_E$ , flight path angle  $\gamma_E$  for generating the operational ballistic capture transfer;

(b) implementing a forward targeting process by varying the velocity magnitude  $V_E$ , and the flight path angle  $\gamma_E$  for convergence of target variables at the moon, the target variables including radial distance,  $r_M$ , and inclination  $i_M$ ; and

(c) iterating step (b) until sufficient convergence to obtain the operational ballistic capture transfer from the earth or the earth orbit to the moon or the moon orbit, and

wherein the object is navigated from the earth or the earth orbit to the moon or the moon orbit using the operational ballistic capture transfer.

17. A computer program memory, storing computer instructions to generate an operational ballistic capture transfer for an object emanating substantially at earth or earth orbit to arrive at the moon or moon orbit using a computer, the computer instructions including:

(a) entering parameters including velocity magnitude  $V_E$ , flight path angle  $\gamma_E$  for said method of generating operational ballistic capture transfer;

(b) implementing a forward targeting process by varying the velocity magnitude  $V_E$ , and the flight path angle  $\gamma_E$  for convergence of target variables at the moon, the target variables including radial distance,  $r_M$ , and inclination  $i_M$ ; and

(c) iterating step (b) until sufficient convergence to obtain the operational ballistic capture transfer from the earth or the earth orbit to the moon or the moon orbit.

18. A method of generating operational ballistic capture transfer for an object emanating substantially at earth or earth orbit to arrive at the moon or moon orbit using a computer implemented process, comprising the steps of:

(a) entering parameters for said method of generating operational ballistic capture transfer;

(b) implementing a forward targeting process by varying the parameters for convergence of target variables at the moon; and

(c) iterating step (b) until sufficient convergence to obtain the operational ballistic capture transfer from the earth or the earth orbit to the moon or the moon orbit.

19. A method of traveling from substantially at earth or earth orbit to the moon or moon orbit in a space vehicle or rocket using an operational ballistic capture transfer, comprising the steps of:

(a) generating the operational ballistic capture transfer by implementing a forward targeting process by varying parameters for said method until convergence of target variables at the moon; and

(b) traveling from substantially at the earth or the earth orbit to the moon or the moon orbit using the operational ballistic capture transfer by the space vehicle or the rocket.

20. A method of generating operational ballistic capture transfer for an object emanating substantially at earth or earth orbit to arrive at the moon or moon orbit using a computer implemented process, comprising the steps of:

(a) entering at least two spherical parameters for said method of generating operational ballistic capture transfer;

(b) implementing a forward targeting process by varying the at least two spherical parameters for convergence of target variables at the moon, while maintaining at least one classical variable used in said forward targeting process fixed; and

(c) iterating step (b) until sufficient convergence to obtain the operational ballistic capture transfer from the earth or the earth orbit to the moon or the moon orbit.

21. A method of traveling from substantially at earth or earth orbit to the moon or moon orbit in a space vehicle or rocket using an operational ballistic capture transfer, comprising the steps of:

(a) generating the operational ballistic capture transfer by implementing a forward targeting process by varying at least two spherical parameters for said method until convergence of target variables at the moon, while maintaining at least one classical variable used in said forward targeting process fixed; and

(b) traveling from substantially at the earth or the earth orbit to the moon or the moon orbit using

the operational ballistic capture transfer by the space vehicle or the rocket.

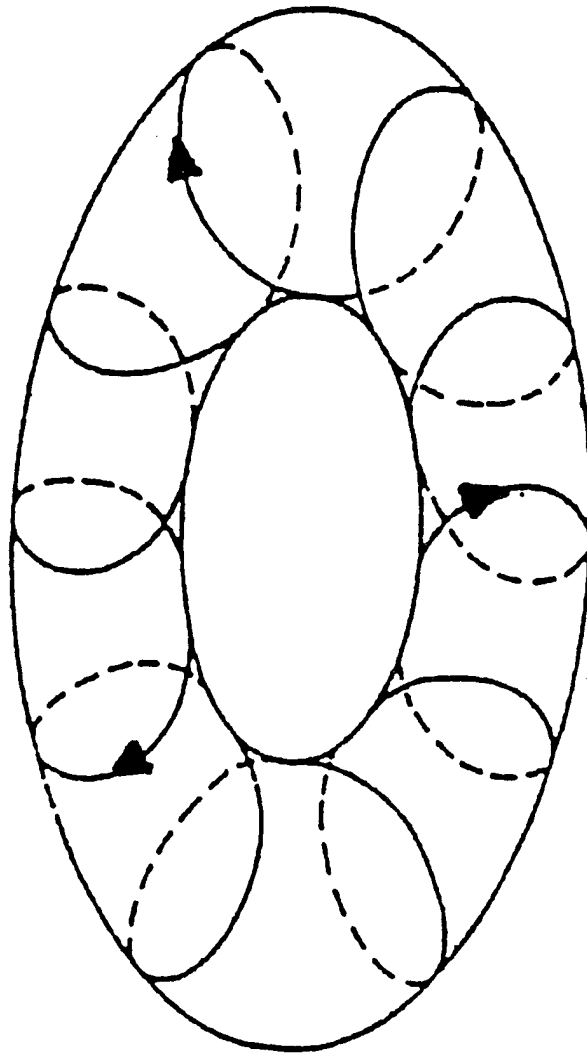

PRIOR ART

FIGURE 1.

PRIOR ART

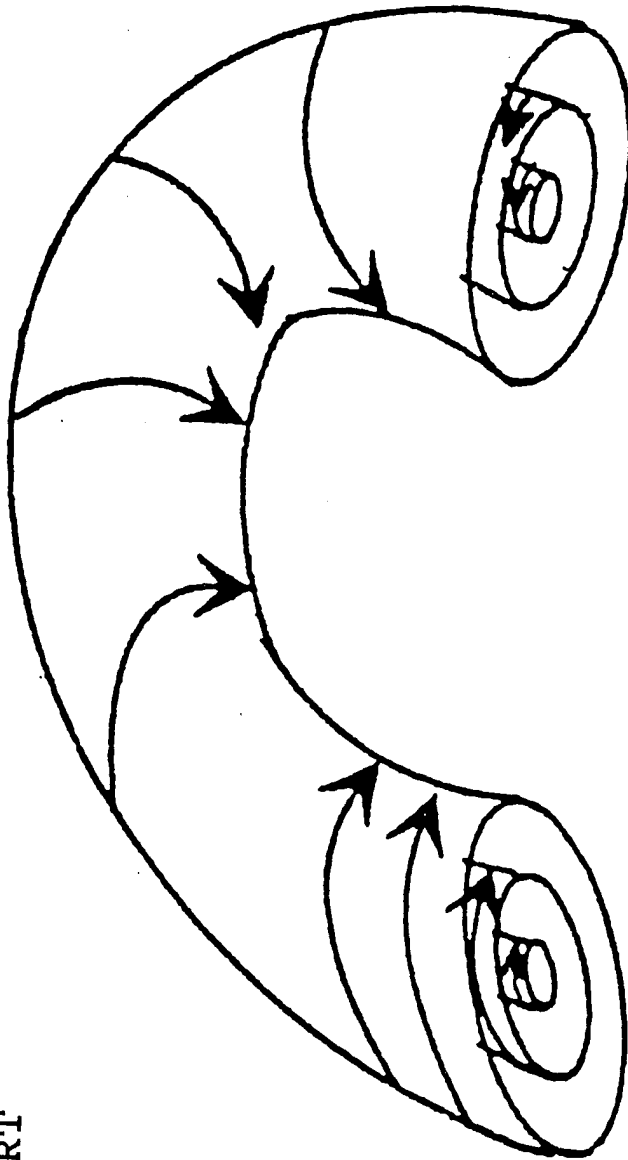

FIGURE 2.

PRIOR ART

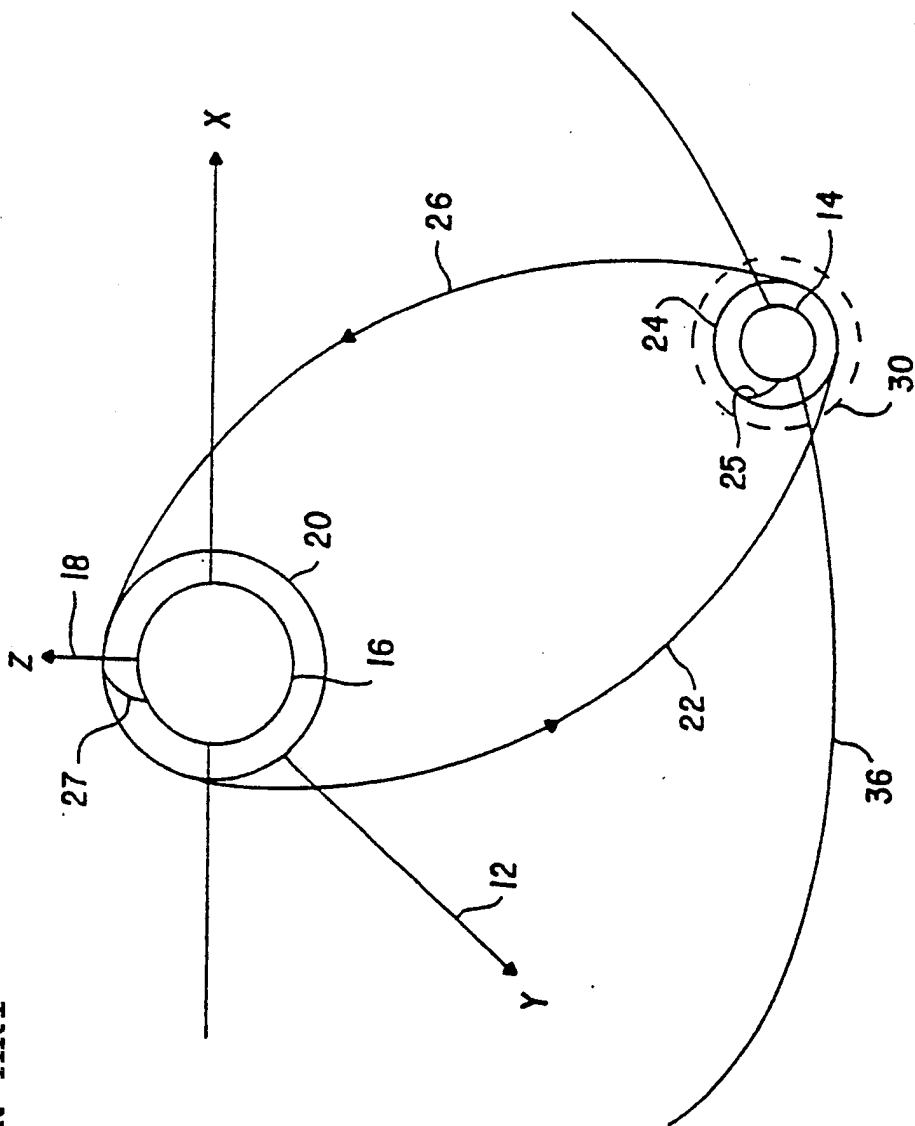

FIG. 3



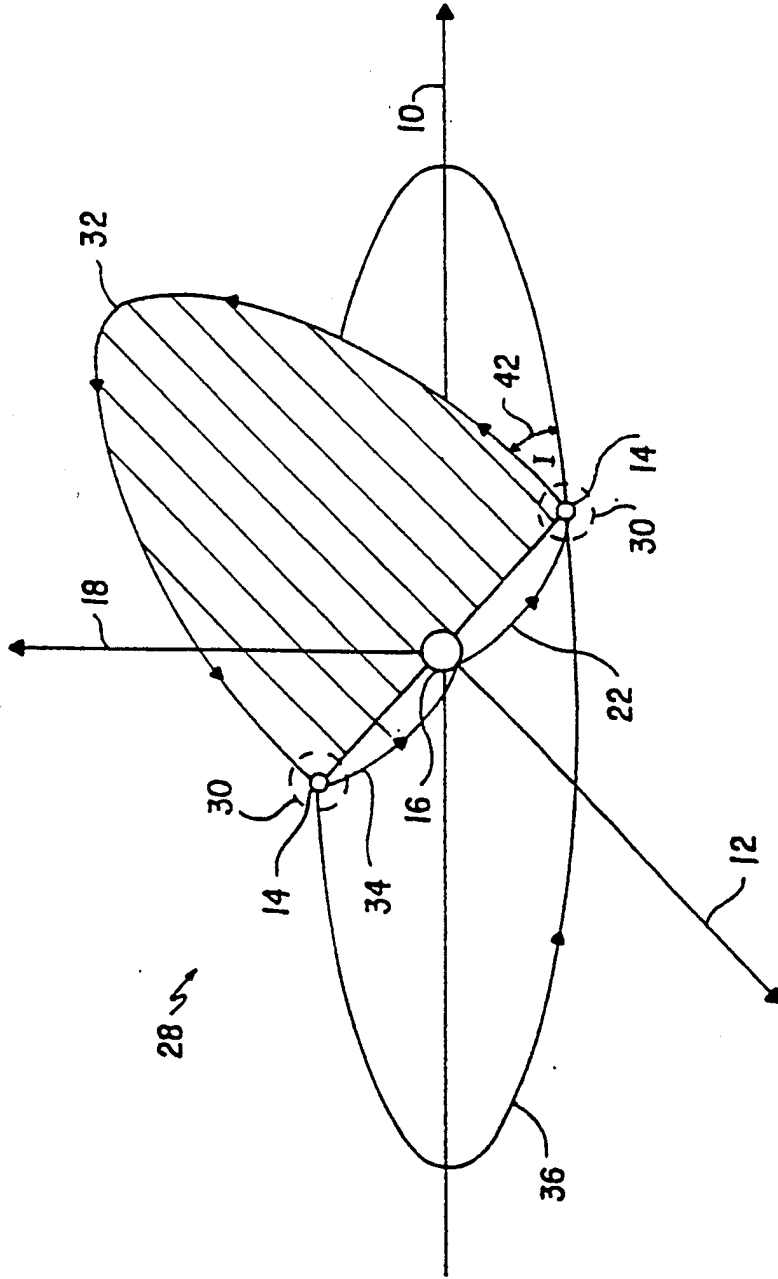
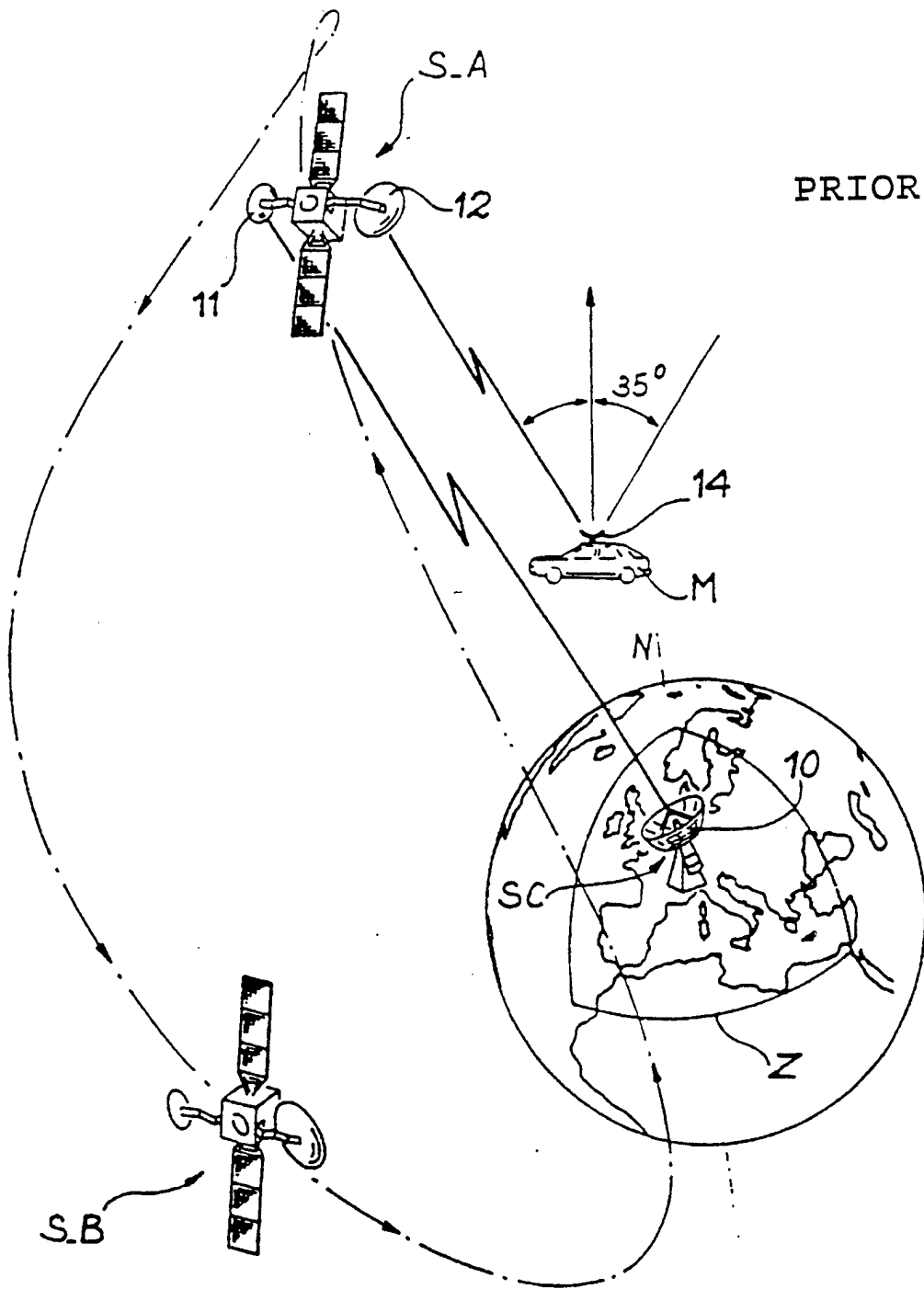

FIG. 4

PRIOR ART



PRIOR ART

FIG. 5

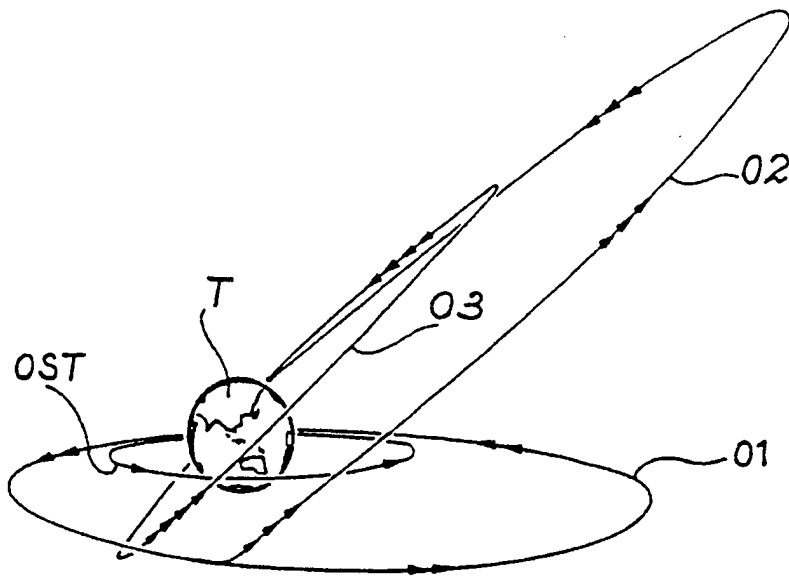
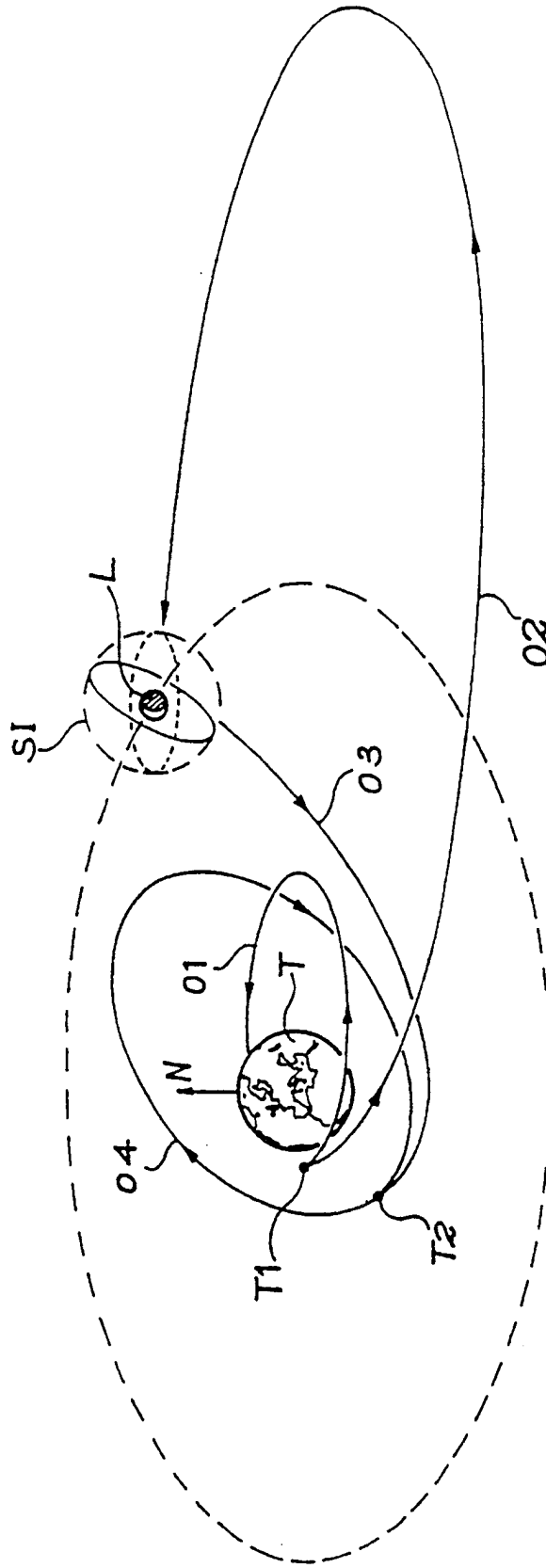

FIG. 6

PRIOR ART

FIG. 7



PRIOR ART

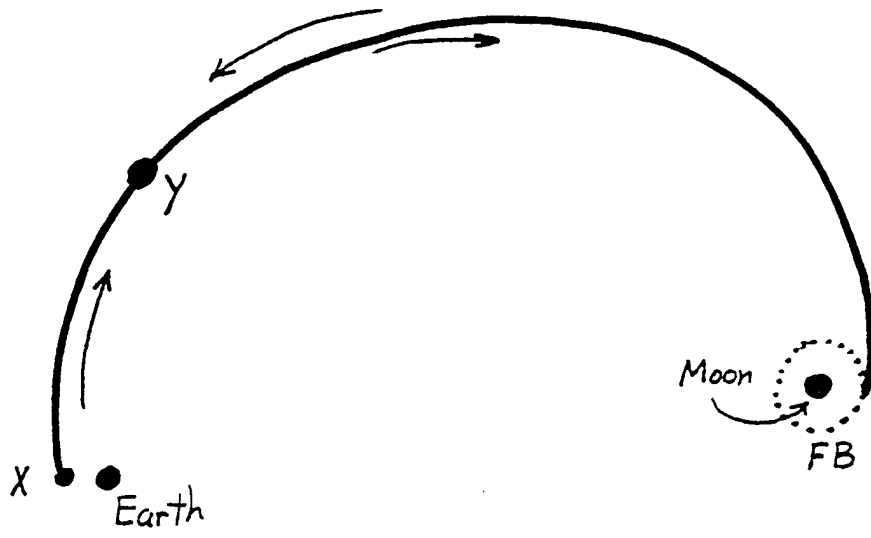

Figure 8

7

Figure 9

Ballistic Capture Transfer

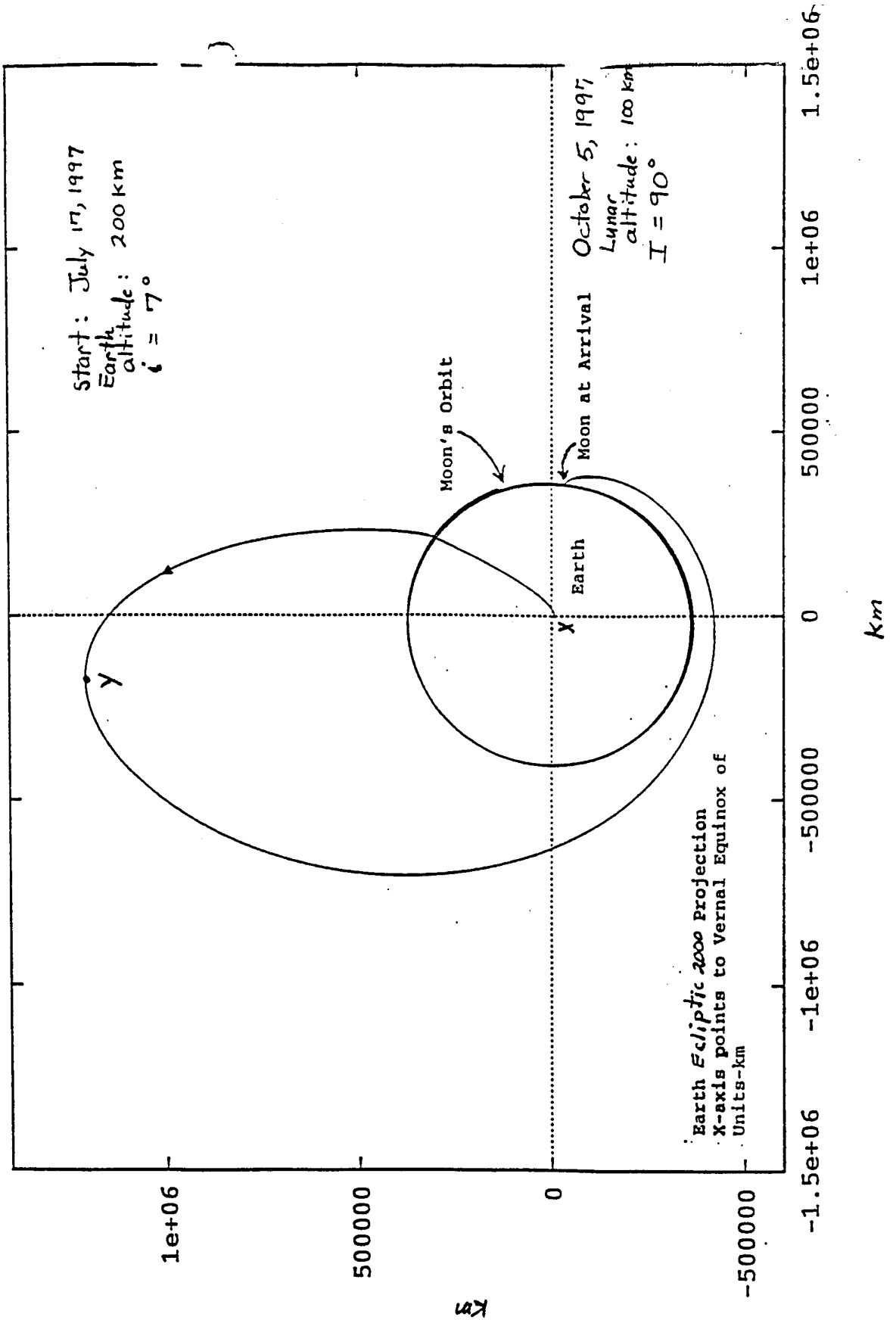
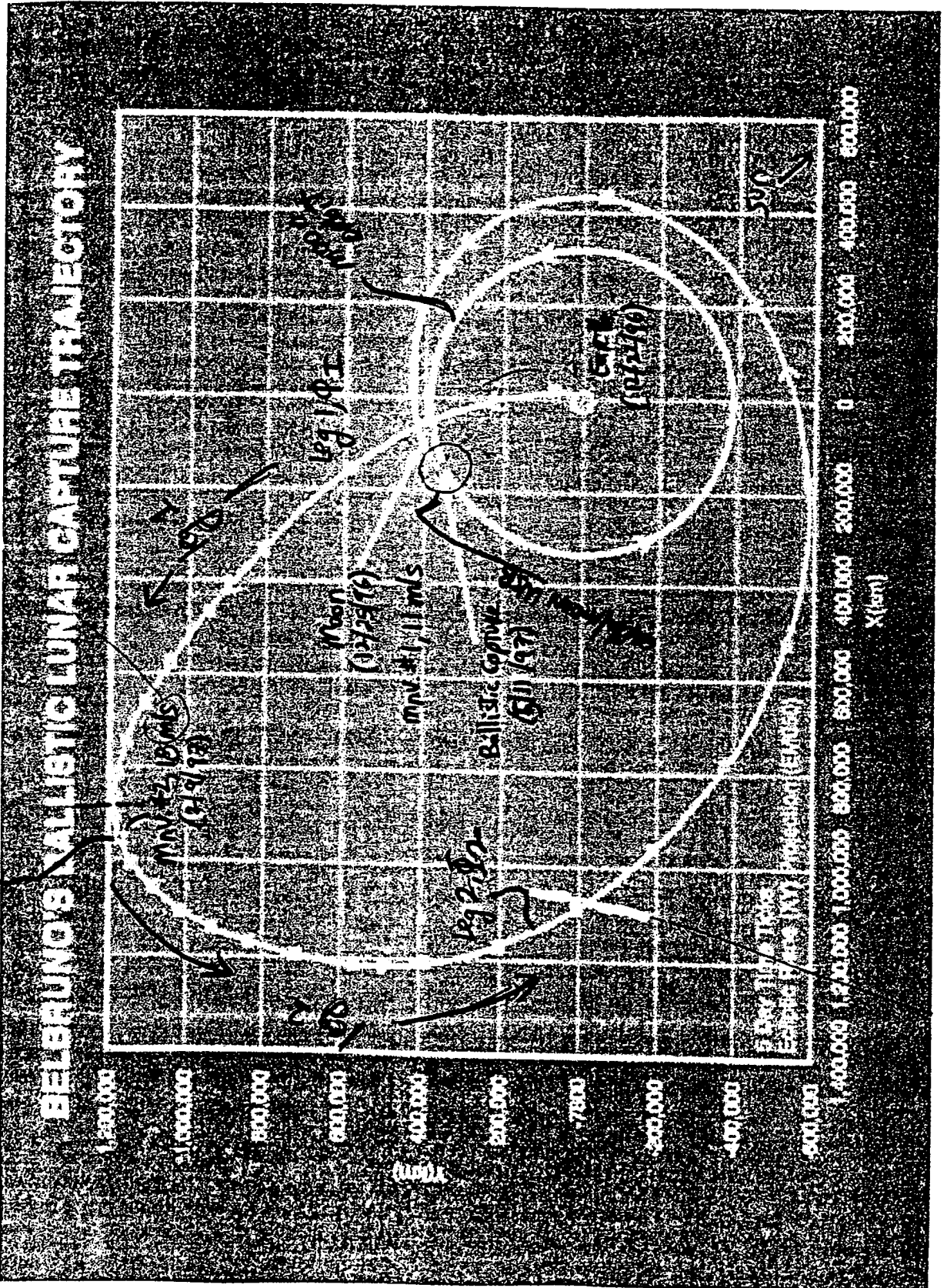
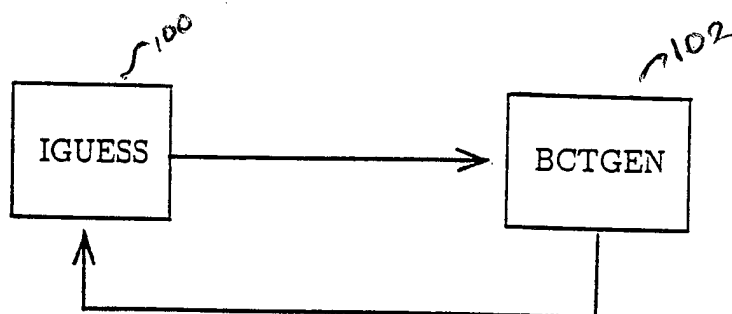

FIG. 10

*egh/sun' wsb*





IGUESS estimates an initial guess in spherical, flightpath coordinates for a BCT transfer. BCTGEN is a targeting-integrating program setup to do a 2X2 search for a BCT transfer.

The parameters  $i$ ,  $\Omega$ ,  $\omega$  are manually walked over to desired given mission parameters. This could be facilitated by an intermediate program which constructs contours..

FIG. 11



So far, we have

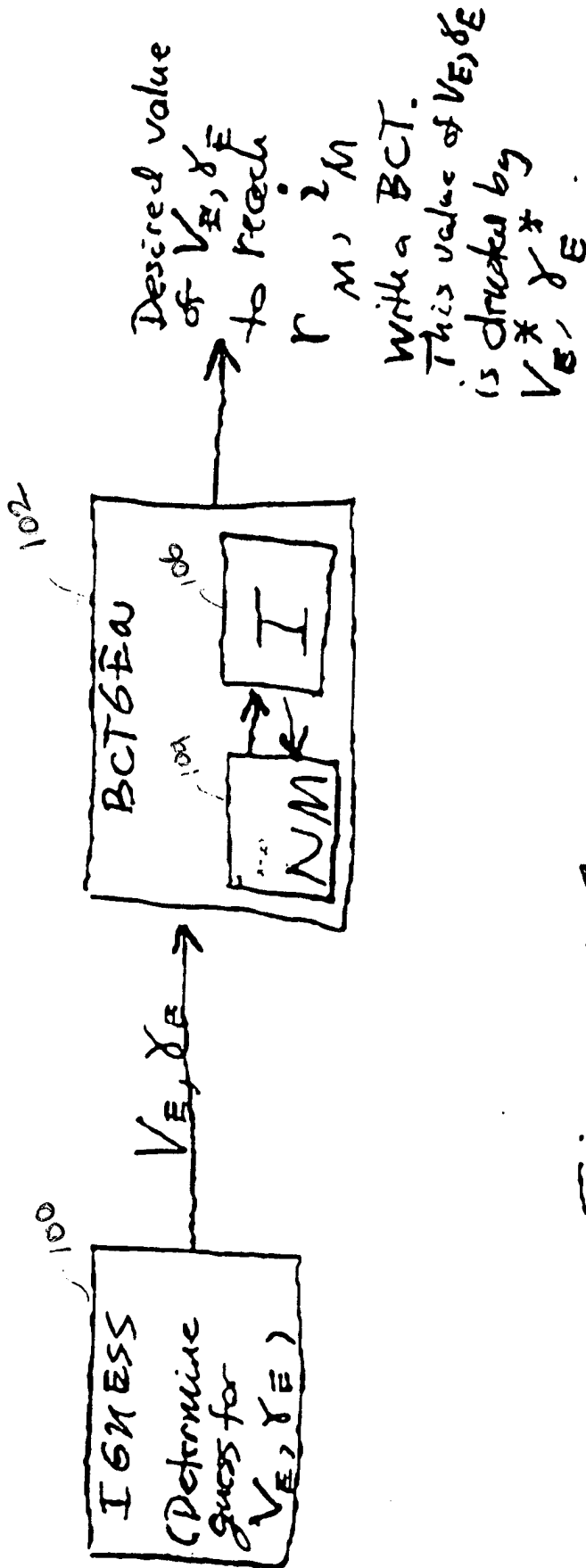
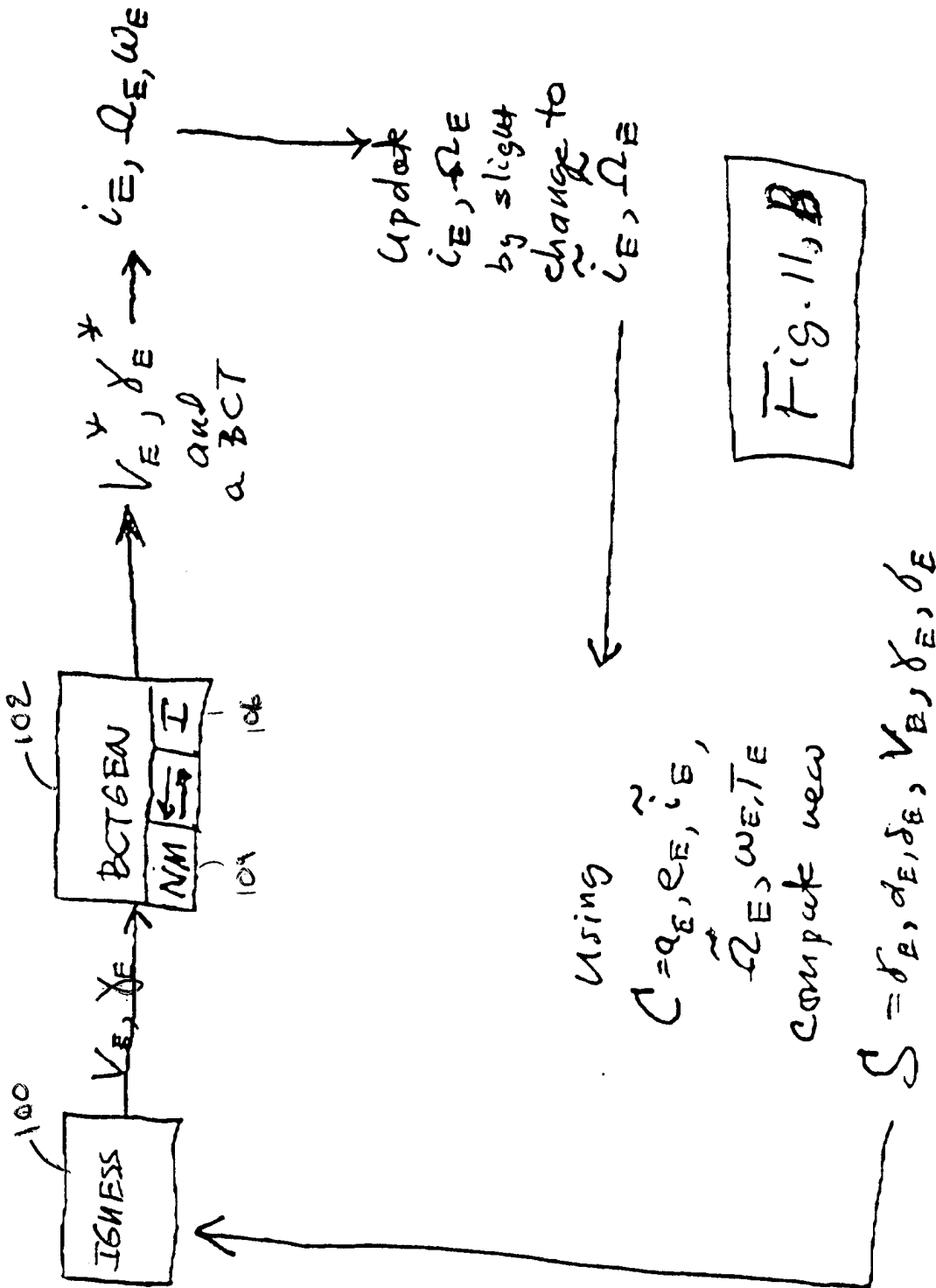

Figure 11A



CURRENT AND PROJECTED UNMANNED LUNAR MISSIONS

Date	No. Lunar Missions	Transfer	Mission Name	Purpose	Country	Mass (KG)	Cost
1991	1	BCT	Hiten	RS	Japan	200	100M
92	0						
93	1	H	Clementine	RS	US	200	50M
94	0						
95	0						
96	0						
97	1	H	Lunar Prospector	RS	US	200	40M
98	1	BCT	Lunar A	RS	Japan	2000	400M
99	1	BCT	Blue Moon	RS	US	50	10M
2000	2		Clementine2	RS (H2O)	US	200	40M
1	2		-----	RS (H2O)	US	400	80M
				RS		400	80M
2	2			RS		400	80M
				RS		400	80M
3	2			RS		600	120M
				RS		600	120M
4	2			RS		600	120M
				RS		600	120M
5	2			RS		600	120M
				RS		600	120M
6	2			RS		600	120M
				RS		600	120M
7	2			RS		600	120M
				RS		600	120M
8	2			LB		22,500	4.5B
9	2			LB		22,500	4.5B
10	4			S		400	80M
11	4			S		400	80M
12	4			S		400	80M
13	4			S		400	80M
14	6			RS, S		600	120M
						Total	11.608 B

Rule - 200 kg to the moon equivalent to 40 M.  
 H=Hohmann, BCT = Ballistic Capture Transfer  
 RS = Robotic Science, LB = Lunar Base, C = Commercial, S = Supplies  
 LB = 1 habitat(40 tons), 1 H2O Converter(4 tons), 1 Dish Antennae(.5 tons),  
 M = Million, B = Billion . 1 Rover, Supplies(.5 tons)

FIG. 12

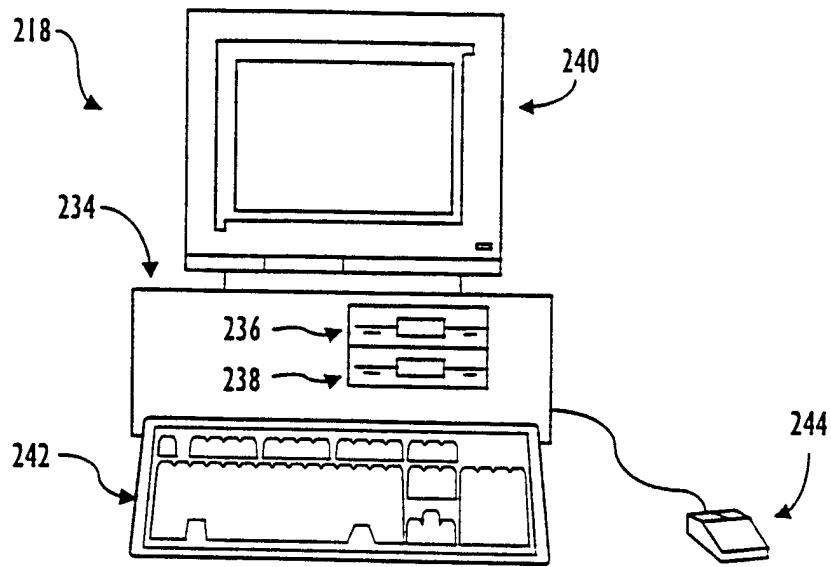

FIG. 13

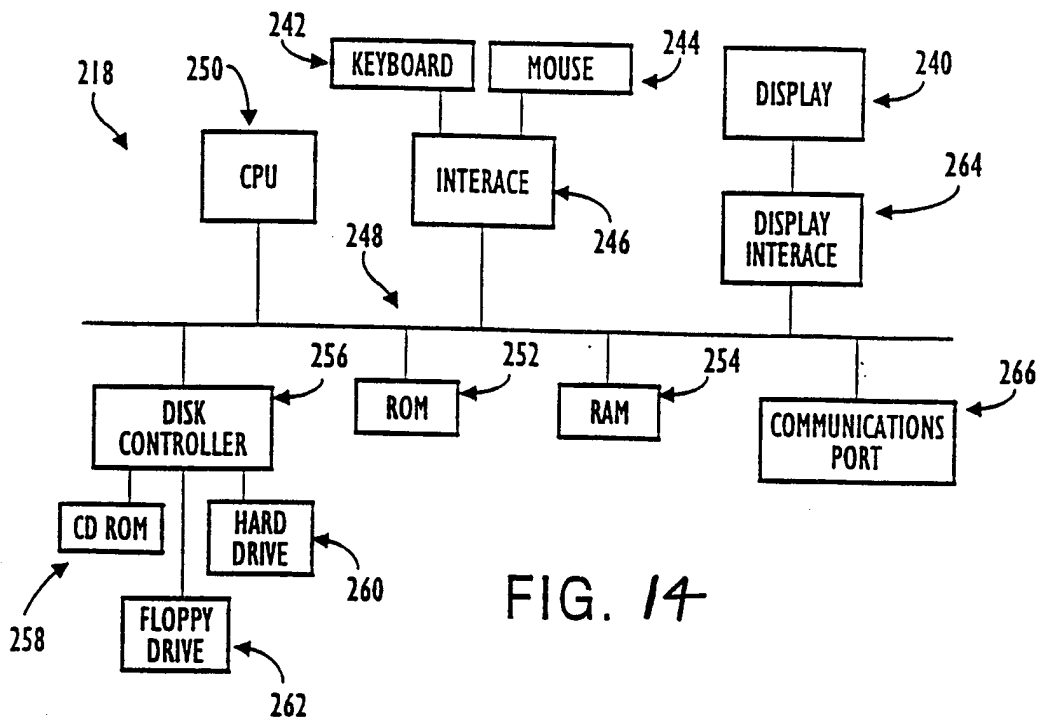

FIG. 14

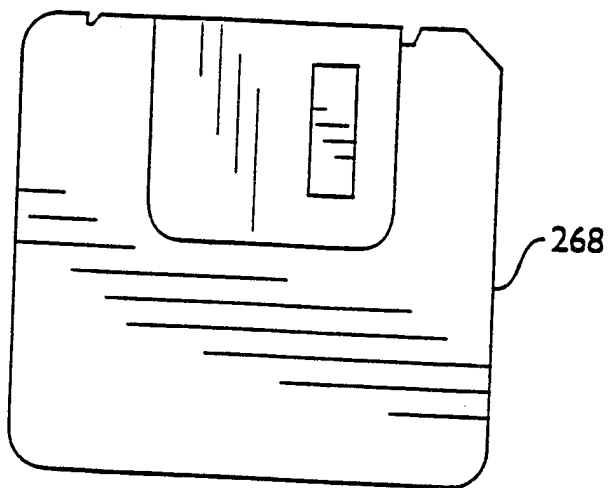

FIG. 15