



HU000028636T2

(19) **HU**(11) Lajstromszám: **E 028 636**(13) **T2****MAGYARORSZÁG**
Szellemi Tulajdon Nemzeti Hivatala**EURÓPAI SZABADALOM**
SZÖVEGÉNEK FORDÍTÁSA

- (21) Magyar ügyszám: **E 08 737558** (51) Int. Cl.: **B65B 5/10** (2006.01)
(22) A bejelentés napja: **2008. 04. 28.** **A61J 1/03** (2006.01)
B65B 61/06 (2006.01)
(96) Az európai bejelentés bejelentési száma: **B65D 75/34** (2006.01)
EP 20080737558
(97) Az európai bejelentés közzétételi adatai: (86) A nemzetközi (PCT) bejelentési szám:
EP 2150464 A2 **2008. 11. 13.** **PCT/IB 08/001049**
(97) Az európai szabadalom megadásának meghirdetési adatai: (87) A nemzetközi közzétételi szám:
EP 2150464 B1 **2015. 12. 09.** **WO 08135825**

(30) Elsőbbségi adatok: 1033806 2007. 05. 04. NL 1033807 2007. 05. 04. NL	(73) Jogosult(ak): Unit Dose Pack B.V., 5571 SL Bergeijk (NL)
(72) Feltaláló(k): VAN ESCH, Jos, J., J., M., NL-5561 TP Riethoven (NL)	(74) Képvisező: SBGK Szabadalmi Ügyvivői Iroda, Budapest

- (54) **Információs kártyának egy buborékfóliába csomagolt tárgyhoz való csatlakoztatására szolgáló eljárás, információs kártya, valamint az információs kártyát használó rendszer**

Az európai szabadalom ellen, megadásának az Európai Szabadalmi Közlönyben való meghirdetésétől számított kilenc hónapon belül, felszólalást lehet benyújtani az Európai Szabadalmi Hivatalnál. (Európai Szabadalmi Egyezmény 99. cikk(1))

A fordítást a szabadalmas az 1995. évi XXXIII. törvény 84/H. §-a szerint nyújtotta be. A fordítás tartalmi helyességét a Szellemi Tulajdon Nemzeti Hivatala nem vizsgálta.



(11) **EP 2 150 464 B1**

(12) **EUROPEAN PATENT SPECIFICATION**

(45) Date of publication and mention
of the grant of the patent:
09.12.2015 Bulletin 2015/50

(51) Int Cl.:
B65B 5/10 ^(2006.01) **B65B 61/06** ^(2006.01)
A61J 1/03 ^(2006.01) **B65D 75/34** ^(2006.01)

(21) Application number: **08737558.0**

(86) International application number:
PCT/IB2008/001049

(22) Date of filing: **28.04.2008**

(87) International publication number:
WO 2008/135825 (13.11.2008 Gazette 2008/46)

(54) **METHOD FOR ATTACHING AN INFORMATION CARD TO AN ITEM PACKAGED IN A BLISTER,
AN INFORMATION CARD AND A SYSTEM USING THE INFORMATION CARD**

VERFAHREN ZUR BEFESTIGUNG EINER INFORMATIONSKARTE AN EINEM IN EINEM BLISTER
VERPACKTEN OBJEKT, INFORMATIONSKARTE UND DIE INFORMATIONSKARTE
VERWENDENDEN SYSTEM

PROCÉDÉ POUR FIXER UNE FICHE D'INFORMATION SUR UN ARTICLE SOUS PLAQUETTE
ALVÉOLÉE, FICHE D'INFORMATION, ET SYSTÈME UTILISANT CETTE FICHE D'INFORMATION

(84) Designated Contracting States:
**AT BE BG CH CY CZ DE DK EE ES FI FR GB GR
HR HU IE IS IT LI LT LU LV MC MT NL NO PL PT
RO SE SI SK TR**

(30) Priority: **05.05.2007 NL 1033806**
05.05.2007 NL 1033807

(43) Date of publication of application:
10.02.2010 Bulletin 2010/06

(73) Proprietor: **Unit Dose Pack B.V.**
5571 SL Bergeijk (NL)

(72) Inventor: **VAN ESCH, Jos, J., J., M.**
NL-5561 TP Riethoven (NL)

(74) Representative: **Griebing, Onno et al**
Octrooibureau Griebing BV
Sportweg 10
5037 AC Tilburg (NL)

(56) References cited:
EP-A- 0 210 820 US-A- 1 816 542
US-A- 4 362 000

EP 2 150 464 B1

Note: Within nine months of the publication of the mention of the grant of the European patent in the European Patent Bulletin, any person may give notice to the European Patent Office of opposition to that patent, in accordance with the Implementing Regulations. Notice of opposition shall not be deemed to have been filed until the opposition fee has been paid. (Art. 99(1) European Patent Convention).

Description

Technical field of the invention.

[0001] The invention relates to a method of attaching an information card to an item packaged in a blister, comprising the step of attaching an information card to the blister. The invention further relates to an information card for attaching to a blister holding a dose of a pharmaceutical.

Background art.

[0002] Pharmaceuticals are being offered in various kinds of packaging. In many cases such packaging holds several doses, such as pills, individually packed but physically interconnected. Each dose can be removed from the packaging at the moment the dose is to be administered. See for example US4362000 and US1816542.

[0003] The packaging has to meet many requirements. The packaging must for instance contain information about the application of the pharmaceutical, and must have a registration number to identify the pharmaceutical, expiration date for quality control, a charge or lot number to allow traceability and often also a barcode for machine readability. The packaging also often provides protection of the pharmaceutical against environmental influences to prevent deterioration between the moment of production and the moment of application (administering).

[0004] Because the individual doses of the pharmaceuticals are often small and to allow standardization of production the information is often applied to the external packaging instead of the actual packaging of the dose.

[0005] It is desirable, as evident from efforts by pharmacists, to be able to provide the information about the pharmaceutical with each individual dose in order to ensure the correct administering of the pharmaceutical to the patient.

[0006] A common type of packaging for one or more doses is a cavity formed around the dose by two layers that are meet around the dose and form a seal where they meet. The dose can be removed from the cavity by applying pressure to one side of the cavity and either forcing the seal apart or fracturing one of the two layers.

[0007] Pharmaceuticals are known to be repackaged. In such a repackaging operation either the entire non-severed blister with multiple doses is being inserted into a new external package or the dose is being removed from the blister and put into another blister or a container of another kind.

[0008] Attempts have been made to add the desired information to the blister of the individual dose. The amount of information that can be added is directly linked to the area available to apply the sticker to and as such often severely limited. Attempts to solve this problem by repackaging the dose into a larger blister result in problems with quality control requirements since the origin of

the pharmaceutical can no longer be established beyond doubt. This further results in liability issues in case of problems arising from the use of the pharmaceutical.

[0009] It is an objective of the present invention to provide a method of applying additional information to a pharmaceutical in a blister according to claim 1 and a corresponding assembly according to claim 3.

Disclosure of Invention.

[0010] By using an information card with an opening, the size of the information card is no longer limited by the size of the blister surrounding the individual dose.

[0011] As much additional information as desired can be applied to the information card by choosing an appropriately sized information card. This allows the information to be complete which ensures the administering of the correct pharmaceutical to the correct patient.

[0012] The blister with the dose is positioned in the opening and is attached to the information card. The opening allows the original functionality and integrity of the blister to be maintained. The information card effectively forms a pas par tout in which the blister is mounted. The blister consequently continues to provide protection of the pharmaceutical against environmental influences to prevent deterioration between the moment of production and the moment of application.

[0013] There is no need for severing the blister to remove the dose but instead the blister's integrity and functionality is maintained.

[0014] The opening further allows inspection of the blister's side that would otherwise be covered by the label and thus the original labeling applied by the manufacturer to the blister remains accessible allowing optimal quality control. Furthermore the blister's predefined way for severing the blister in order to remove the dose is unaffected, i.e. the patient can remove the dose in the familiar way. The blister is a blister sub section of a multi-dose blister obtained by dividing the multi-dose blister comprising multiple individually packed doses into blister subsections.

[0015] Pharmaceutical doses are often individually presented to the patient in order to prevent the patient from taking more than the prescribed doses. A blister comprising multiple doses thus poses a risk in that the patient might take more doses than allowed or desired.

[0016] By cutting up the blister holding multiple doses into subsection holding fewer doses this risk is greatly reduced.

This is also desirable in hospitals etc since the pharmaceuticals are stored by the hospital and only the required doses are presented to the patient. In case of a blister comprising multiple doses the blister must be returned to the storage location after one or more doses have been removed for administering to the patient. This is not only a burden to the staff but also introduces an additional risk of mixing up two patient's pharmaceuticals.

[0017] The method thus allows the addition of the in-

formation card to a single dose, still in its subsection of the blister, cut from the blister.

Since the subsection of the blister still provides the full protection to the dose, no special environment or special room is needed as would be the case when the cavity in the blister holding the dose would be severed. If the dose is delivered in a single dose blister from the factory, the division of the blister is of course not required.

[0018] A rim of the opening of the information card is provided with glue for attaching the information card to the blister.

[0019] Only the rim needs to be provided with glue for gluing the information card to the blister or blister subsection. This provides a defined zone where the blister is bonded to the information card which saves material relative to a situation where a sticker is applied to the blister since a sticker usually has glue applied to its entire back surface.

[0020] In another embodiment of the method the information card is attached to a side of the blister designed for releasing the dose from the blister.

Applying pressure to the blister severs that side of the blister designed for releasing the dose from the blister. When the information card is attached to the side designed for releasing the dose it helps in holding and stabilizing the blister when pressure is to be applied to the other side of the blister.

(Surface is better than side)

[0021] In another embodiment of the method at least two information cards are connected to each other.

[0022] Having two or more information cards connected allows the construction of a strip of information cards that can be handled as one item. This simplifies the use in automated machines for executing the method according to the invention.

It also simplifies the use in a care environment such as a hospital.

[0023] In another embodiment of the method the information cards can be disconnected by tearing.

[0024] Two information cards can be separated by tearing.

This can be achieved by perforating the section between two cards where they are joined or by other means of weakening this section, such as thinning the information card material.

[0025] In another embodiment of the method the two information cards are different and are attached to blisters holding different pharmaceuticals or different sized doses of the same pharmaceutical.

[0026] Besides of having the same pharmaceutical in all information cards that are connected, the method also allows the placement of doses of different pharmaceuticals in the information cards. For instance in the case of two information cards being connected, the first information card is attached to a dose of the first pharmaceutical and the second information card is attached to a dose of

the second pharmaceutical. The first information card displays the information about the first pharmaceutical and the second information card displays the information about the second pharmaceutical. This allows the strip of information cards to be designed to reflect a sequence of administering of pharmaceuticals, for instance a sequence followed from patient to patient in a ward.

[0027] In another embodiment of the method the information card comprises a barcode.

[0028] A barcode allows the positive electronic identification of the attached pharmaceutical. The barcode can be read using a barcode reader in or attached to a handheld device and be compared to information in a bar code on a bracelet on the patient's arm, read by the same barcode reader. If a mismatch is detected, for instance by comparing medication data linked to a particular patient and the information card of the medication intended to be administered, and an alarm can be sounded and the administering of the wrong pharmaceutical to the patient can be prevented.

[0029] In another embodiment of the method each information card displays the name of the patient to whom the dose in the attached blister is to be administered.

[0030] In addition to the barcode, or as a substitute, the name of the patient is printed on the information card. This allows a final check of the correctness of the administering by the member of the medical staff, the physician or the patient himself. This enhances the safety of the medication. Having the name of the patient on the information card, as well as information that is normally only found on the external box in which the blisters are shipped, and still being able to check the manufacturers print on the blister itself provides a very secure system to ensure that the patient only receives the correct pharmaceuticals.

[0031] The information card can also show how the pharmaceutical should look making identification by the patient easy. Other information to be displayed include the pharmacist's name and instructions, the physician's name, prescription and instructions, and side effect information so that in an emergency situation all information is available.

[0032] In another embodiment of the method all pharmaceuticals in blisters attached to the information cards connected to each other are to be administered to the same patient.

[0033] When multiple information cards, and thus pharmaceutical doses, are connected forming a strip of information cards, the strip can be customized for a particular patient.

[0034] The strip can contain doses of different pharmaceuticals, which can be placed in the strip in an order that matches the prescribed sequence of administering. Since the sequence and combination of pharmaceuticals is unique for every patient, placing different pharmaceuticals into a multi dose blister cannot be easily achieved in a pharmaceutical plant. The present invention allows personal and unique combinations of pharmaceutical

doses to be placed in a strip of information cards for each patient. Providing information about each dose on the information card allows verification of the correctness of the compilation of the strip.

[0035] In another embodiment of the method a pick and place machine is used to position the blister in the opening of the information card.

[0036] In order to compile such a personal strip for a patient often multiple pharmaceuticals have to be included in the strip. A pick and place machine as known from electronic circuit board assembly can be used to position the doses in the corresponding openings in the information cards. The pick and place machine is able to retrieve different doses from feeding rails, just as it is able to retrieve electronic components from feeding rails.

[0037] To increase the safety of the medication, optical recognition, as is already used to verify correct component selection and orientation during assembly of electronic circuit boards, can be used to verify that the picked blister is the correct blister and orientated correctly. After placement in the opening of the information card the optical recognition can also verify the correctness of the placement.

The blister is provided to the pick and place machine temporarily attached to a tape ordinarily used for providing Surface Mount Technology components to the pick and place machine. By using a temporary adhesive to attach the blister to a normal SMT machine supply tape as commonly used with SMT machines there is no need for extensive modifications to the SMT machine.

[0038] Just as in a hospital or member with members of the medical staff, the invention can also be used in a home setting or nursing home where the patient, or another person, can within the framework of the invention perform the tasks described in this document as being performed by the member of the technical staff.

The invention will now be described based on figures.

Brief Description of Drawings.

[0039]

Figure 1 shows a multi-dose blister.

Figure 2 shows rectangular blister sub sections obtained by cutting the multi-dose blister.

Figure 3 shows circular blister sub section obtained by cutting the multi-dose blister.

Figure 4 shows a strip of connected empty information cards.

Figure 5 shows a strip for a single patient containing a mix of pharmaceuticals.

Figure 6 shows a strip for multiple patients.

Figure 7 shows the loading of the strip of information cards with blister subsections.

Figure 8 shows a cross section of an information card attached to the top of a blister sub section.

Figure 9 shows a cross section of an information card attached to the bottom of a blister subsection.

Figure 10 shows a dose dispenser for use with the present invention.

Figure 11 shows a container for holding strips of information cards.

Figure 12 shows a closed loop system in which the information cards are used.

Modes for Carrying Out the Invention.

[0040] Figure 1 shows a multi-dose blister.

[0041] The multi-dose blister 1 is known from the prior art. It contains multiple doses of a pharmaceutical (14 shown). The blister 1 can be divided into 14 blister sub sections 2a, 2b, 2c, 2d, 2e, 2f, 2g, 2h, 2i, 2j, 2k, 2l, 2m, 2n where each blister subsection 2a, 2b, 2c, 2d, 2e, 2f, 2g, 2h, 2i, 2j, 2k, 2l, 2m, 2n comprises a single dose. In the first blister sub section 2a the single dose 4 is located in a cavity 3.

The cavity 3 provides a protection of the dose both from mechanical damage and environmental influences such as humidity. Pharmaceuticals such as the dose 4 are often packaged in the cavity 3 in a strictly controlled environment. This is to ensure that the right pharmaceutical is packaged in the right blister 1 and that the packaging is properly sealed, and that all other requirements and goals commonly known from quality control in the pharmaceutical industry are met. When the multi-dose blister 1 leaves the factory and it's strictly controlled environment a print on one surface of the multi-dose blister 1 allows the identification of the pharmaceutical contained in the blister 1.

[0042] Figure 1 also shows straight dashed lines 6, 7 that indicate perforation lines along which a single dose blister sub section 2a, 2b, 2c, 2d, 2e, 2f, 2g, 2h, 2i, 2j, 2k, 2l, 2m, 2n can be separated from the rest of the multi dose blister 1. Often multi-dose blisters 1 have such perforated lines but in the case of the present invention both the straight dashed lines 6,7 and the dashed circles 5 indicate how the multi-dose blister 1 can be divided into single dose blister sub section 2a, 2b, 2c, 2d, 2e, 2f, 2g, 2h, 2i, 2j, 2k, 2l, 2m, 2n before being attached to an information card. Other shapes are of course also possible as long as the cavity 3 is not severed and sufficient surface area remains for attaching the single dose blister sub section 2a, 2b, 2c, 2d, 2e, 2f, 2g, 2h, 2i, 2j, 2k, 2l, 2m, 2n to an information card.

[0043] Figure 2 shows rectangular blister sub sections obtained by cutting the multi-dose blister.

[0044] When the multi-dose blister 1 is divided along the straight dashed lines 6,7 of figure 1 the single dose blister sub sections 2a, 2b, 2c, 2d, 2e, 2f, 2g, 2h, 2i, 2j, 2k, 2l, 2m, 2n as shown in figure 2 result. The area of the single dose blister sub sections 2a, 2b, 2c, 2d, 2e, 2f, 2g, 2h, 2i, 2j, 2k, 2l, 2m, 2n minus the area of the cavity 3 can be used to attach the single dose blister sub sections 2a, 2b, 2c, 2d, 2e, 2f, 2g, 2h, 2i, 2j, 2k, 2l, 2m, 2n to the information card (not shown).

[0045] Figure 3 shows circular blister sub section ob-

tained by cutting the multi-dose blister.

[0046] When the single dose blister sub sections are obtained by punching out circles from the multi-dose blister 1 along the circular dashed lines 5 of figure 1, the single dose blister sub sections 2o, 2p, 2q, 2r, 2s, 2t, 2u, 2v, 2w, 2x, 2y, 2z, 2aa, 2ab as shown in figure 3.

[0047] The area between the outer edge 5 and the cavity 3 is available for attaching the single dose blister sub sections 2o, 2p, 2q, 2r, 2s, 2t, 2u, 2v, 2w, 2x, 2y, 2z, 2aa, 2ab to the information card (not shown).

[0048] Figure 4 shows a strip of connected empty information cards.

[0049] For clarity reason the strip 10 of connected empty information cards is shown against a background 11 so that it becomes clear what areas are cut-outs 13, 17. The strip comprises multiple information cards 12a, 12b, 12c, 12d, 12e, 12f that are inter-connected to form a single strip 10. Each information card 12a, 12b, 12c, 12d, 12e, 12f has an opening 13 (shown in all information card but only labeled on the first information card 12a) where a single dose blister sub section (or, of course, a single dose blister that was manufactured as a single dose blister in the first place instead of being cut-out from a multi-dose blister) can be attached to the information card 12a. Each information card 12a, 12b, 12c, 12d, 12e, 12f is also provided with a labeling area 15 (again, only shown for the first information card 12a for clarity reasons) where information about the pharmaceutical or the patient can be printed to be displayed.

[0050] As shown, the information can comprise the name of the pharmaceutical, tracking information, expiry date, name of the target patient to whom the dose is to be administered, and a bar code to allow machine reading of the information for tracking from the factory until dose reaches the patient.

[0051] Often the surface of multi-dose blisters does not provide sufficient room to display all this information. In addition the surface is often unsuitable for adding information outside the factory due to poor ink adhesion etc, regardless of the available area.

[0052] By attaching an information card 12a, 12b, 12c, 12d, 12e, 12f to the blister sub section, not only the useable area can be increased as desired to accommodate any information needed, but also a material can be chosen that allows information to be printed on the information cards using common inks and printers because the material of which the information card is made does not provide to protection to the single dose sub section, hence allowing a greater degree of freedom in selecting the information card material.

[0053] Other information that can be included on the information card 12a, 12b, 12c, 12d, 12e, 12f includes instructions for use or predetermined times and dates the pharmaceutical should be administered, all individually catered to a particular patient. Alternatively to printing directly on the information card 12a, 12b, 12c, 12d, 12e, 12f the information can be printed on a label, e.g. a sticker, which is in turn attached to the information card.

[0054] The individual information cards 12a, 12b, 12c, 12d, 12e, 12f can be separated from the strip 10 by reducing the information card's material strength and thus creating a tear-off or break-off line 18. For use in drug dispensers the strip 10 can be provided with a series of sprocket holes 17 or other means for the drug dispenser to engage the strip 10.

[0055] Figure 5 shows a strip for a single patient containing a mix of pharmaceuticals.

[0056] The information cards 12a, 12b, 12c, 12d, 12e, 12f are labeled in figure 5 to receive different pharmaceuticals. The information 20a, 20b, 20c, 20d, 20e, 20f displayed by each information card 12a, 12b, 12c, 12d, 12e, 12f is allowed to differ but the patient's name stay the same. Such a strip allows the distribution of a strip of pharmaceuticals to the patient for instance in the morning, containing all the pharmaceuticals he needs to take during the day, further allowing the sequence and time for administering to be prescribed by the label on each information card 12a, 12b, 12c, 12d, 12e, 12f and/or by the physical sequence of the pharmaceuticals in the strip.

[0057] The strip can thus be individually prepared for the patient, which cannot be achieved in a large pharmaceutical factory.

[0058] Figure 6 shows a strip for multiple patients.

[0059] The information cards 12a, 12b, 12c, 12d, 12e, 12f are labeled in figure 6 to receive the same pharmaceuticals. The information 20a, 20b, 20c, 20d, 20e, 20f displayed by each information card 12a, 12b, 12c, 12d, 12e, 12f shows the same pharmaceutical to be attached to the information card 12a, 12b, 12c, 12d, 12e, 12f but shows different patient names. Such a strip allows the distribution of a strip of pharmaceuticals to a ward with multiple patients receiving the same medication. The member of the medical staff in the ward can then take the strip and distribute the individual sections to the appropriate patients or use the strip and expel the pharmaceutical at the patient's bed side. When returning from her round the empty positions in the strip form positive evidence that patient received the pharmaceutical. Also, having the patient's name on the information card 12a, 12b, 12c, 12d, 12e, 12f allows verification by the patient that he is being administered the correct pharmaceutical. The strip can thus be individually prepared for a ward, which cannot be achieved in a large pharmaceutical factory. It enhances the efficiency of the work in the ward and provides additional checks against incorrect administering of drugs in the ward.

It is self evident that various combinations can be made beyond figure 4, 5 and 6, for instance a strip can be tailored for a ward like in figure 6 while at the same time allowing different pharmaceuticals to be included in the strip for the same patient as in figure 5. The sequence of patients on the strip can be matched to the sequence in which the member of the medical staff makes her round in the ward.

[0060] Figure 7 shows the loading of the strip of information cards with blister subsections.

[0061] The strip shown in figure 7 has the same configuration as the strip shown in figure 5. Different types of pharmaceuticals in their blister sub sections 2o, 2p, 2n, 2q, 2r, 2b are shown separately as obtained by separating the blister sub sections 2o, 2p, 2n, 2q, 2r, 2b from the multi-dose blister as explained in figure 1, 2 and 3. In addition, the same blister sub sections 2o, 2p, 2n, 2q, 2r, 2b are shown when attached to the corresponding information cards 12a, 12b, 12c, 12d, 12e, 12f.

The blister sub section 2o, 2p, 2q and 2r contain a dose of aspirin and are attached into the corresponding information cards 12a, 12b, 12d, 12e, while the blister sub sections 2b, 2n contain codeine and are attached to their corresponding information cards 12c, 12f.

[0062] A sequence of administering the pharmaceuticals for Mr. J. Doe as indicated by the strip is aspirin, aspirin, codeine, aspirin, aspirin, codeine.

It is clear from figure 7 that the information card 12a, 12b, 12c, 12d, 12e, 12f provides an additional advantage in that it allows differently shaped blister sub section 2o, 2p, 2n, 2q, 2r, 2b to be attached to the same information cards. It is evident that the opening 13 must be large enough to accommodate the pharmaceutical and any part of the blister sub section 2o, 2p, 2n, 2q, 2r, 2b that has an elevated profile and that there must be some overlap between the rim of the opening 13 and the blister sub section 2o, 2p, 2n, 2q, 2r, 2b in order to be able to attach the blister sub section 2o, 2p, 2n, 2q, 2r, 2b to the information card 12a, 12b, 12c, 12d, 12e, 12f. As is shown in figure 7 both circular cut out blister sub sections 2o, 2p, 2q, 2r, as well as rectangular cut out blister sub sections 2b, 2n can be accommodated by the same opening.

[0063] Strips with differently shaped openings can be provided so that various blister sub section shapes and sizes can be accommodated.

The first information card 12a with the attached blister sub section 2o indicates how the blister sub section 2o is attached to the information card 12a.

The cavity 3 holding the pharmaceutical dose 4 is positioned in the opening 13. The outer edge 5 of the blister sub section 2o overlaps with the information card 12a, i. e. the hole 13 is smaller than the blister sub section 2o, but large enough to either let pressure be applied to the dose (for instance pill or capsule) or to let the dose pass through the opening when being expelled from the cavity.

[0064] Figure 8 shows a cross section of an information card attached to the top of a blister sub section.

[0065] Typical blisters for packing pharmaceutical doses have two surfaces 30, 33 of which typically a first surface 33 is designed to exercise force on the dose 4 to expel the dose 4 through the second surface 30. Figure 8 shows a first option to attach the information card 12a to the top of blister sub section 2o. In order to attach the information card 12a the rim around the hole 13 is provided with an adhesive 31. Figure 8 further shows the sprocket hole 17 for use of the strip in a medication dispenser. Also shown is a sticker 32 attached to the information card 12a carrying the information about patient

and pharmaceutical. Instead of using a sticker 32 the area indicated can also be used for printing the information directly on the information card 12a.

[0066] It is self evident that the label 32 can also be affixed to the opposite site of the information card 12a, preferably taking care not to cover the blister sub section surface 30 through which the dose 4 is to be expelled from the cavity 3.

[0067] Affixing the label 32 on that side of the information card 12a where the information on the blister 2o is visible has the advantage of easy comparison of the information on the information card 12 and the information on the blister 2o.

[0068] Affixing the label 32 such that the dose 4 cannot be expelled without damaging the label 32 and at the same time proving the label 32 with an adhesive that allows the label to be removed from the information card 12a, improves traceability of the administering of the dose 4 as the member of the medical staff is obliged to remove the label 32 before expelling the dose 4, after which the label can be affixed to a report list proving that the dose 4 has actually been presented to the patient. Positioning the label 32 in this way also assists in attaching the blister sub section 2o to the information card 12a.

[0069] Figure 9 shows a cross section of an information card attached to the bottom of a blister subsection.

[0070] Figure 9 shows a second option to attach the information card 12a to the bottom of blister sub section 2o. In order to attach the information card 12a the rim around the hole 13 is provided with an adhesive 31.

[0071] This second option has the advantage of using the structural strength of the information card 12a to support the blister sub section when applying force to the cavity 3 to expel the dose 4. The adhesive 31 does not have to provide as much adhesion as in the first option which allows a cheaper adhesive, or alternative mechanical means to be used. Figure 9 further shows the sprocket hole 17 for use of the strip in a medication dispenser. Also shown is a label 32 attached to the information card 12a carrying the information about patient and pharmaceutical. Instead of using a label 32 the area indicated can also be used for printing the information directly on the information card 12a.

[0072] It is self evident that the label 32 can also be affixed to the opposite site of the information card 12a.

[0073] Affixing the label 32 such that the dose 4 cannot be expelled without damaging the label 32 and at the same time proving the label 32 with an adhesive that allows the label 32 to be removed, improves traceability of the administering of the dose 4 as the member of the medical staff is obliged to remove the label 32 before expelling the dose 4, after which the label 32 can be affixed to a report list proving that the dose 4 has actually been presented to the patient.

[0074] The original manufacturer's protection of the medical dose remains intact by punching or cutting the individual cavities holding the doses from the multi-dose blister. The integrity of the cavity and consequently the

protection is maintained.

[0075] Because of the division into blister sub sections the present invention does not repackaged the dose as the dose remains in it's original protective cavity, it merely changes the size and shape of the multi-dose blister. The result is that the manufacturer's traceability and warranty are unaffected and expensive investigations into possible changes in expiration date are avoided. The division of the multi-dose blister and the attachment of the blister sub sections to the information cards can be performed in a standard room without expensive investments in air treatment.

[0076] The blister sub sections are transported by means of vibration to a Surface Mount Technology pick and place machine. Using the SMT pick and place machine the blister sub sections are positioned in the opening of the information card.

[0077] Figure 10 shows a dose dispenser for use with the present invention.

[0078] The dose dispenser 109 comprises a container 110 holding the strip of information cards 106, or another suitable carrier 106 such as interconnected bags or blisters, in a rolled-up form to be dispensed through a dispenser opening 116. The container 110 simplifies the insertion of the roll containing the pharmaceutical packaging into the dose dispenser 109. The dose dispenser 109 further comprises a lid 101 for access to the innards of the dose dispenser and can be provided with a lock 102 for preventing removal of or tampering with the container 110.

[0079] An optional digital scanner 103 allows one form of control of the dispensing process by scanning the information on the carrier 106, for instance of the bar code on the information card of the present invention. The carrier 106 is advanced so that it emerges from the dose dispenser 109 and becomes accessible for the user, for instance member of the medical staff or patient. The advancement of the carrier 106 can be achieved by manual operation or by means of gear 112 coupled to an electric motor 117. The gear 112 engages with a container gear 114 comprised in the container 110 which in turn is coupled to a sprocket 111 for driving the carrier 106. For this, the carrier 106 is provided with openings as shown in the description of the information cards. The sprocket 111 engages with the openings in the carrier 106, allowing the electric motor to drive the carrier 106 forward or backward.

[0080] The dose dispenser 109 can be provided with a display/keyboard unit 104 and a speaker 105 for interacting with the user. The display 104 can display the patients name, name of pharmaceutical or indicate when the dispensed pharmaceutical has to be administered.

[0081] The container gear and the sprocket 111 are positioned inside the container and are exchanged together with the container 109.

[0082] The gear 112 and the container gear 114 can be replaced by other drive means that can be easily decoupled such as two wheels that are coupled by friction.

[0083] The motor, digital scanner 103 and the display/keyboard unit 104 are coupled to and controlled by the controller 107. The controller 107 comprises an interface 108 which can be connected to a network for interfacing to a computer which comprises for instance a database of pharmaceuticals and/or patients.

[0084] Figure 11 shows a container for holding strips of information cards

[0085] The container 110 comprises a storage area 113 where the carrier 106 is stored, for instance rolled up in order to save space and to facilitate orderly dispensing of the carrier 106.

[0086] The container 110 comprises means to drive the carrier 106 forward and backward. The backward motion is used when the dose dispenser detects that the carrier 106 has not been taken by the user. Backward motion allows the carrier section exposed outside the dose dispenser to be retracted into the dose dispenser to reduce the opportunity for other persons to take the carrier 106.

[0087] The drive means can comprise a sprocket 111 for engaging with the carrier 106 and a container gear 114, the sprocket 111 being coupled to the container gear 114 for instance via an axle 115. The axle 115, in addition to coupling the container gear 114 and the sprocket 111, also positions the container gear/sprocket assembly in the container. For this the container has holes of cavities in which the axle is held and positioned.

[0088] In order to ensure positive engagement between the sprocket 111 and the carrier 106 the container comprises a curved area forming an arc 116 of which the center coincides with the center of the sprocket 111. This ensures that more than one sprocket tooth / sprocket hole engagement is achieved.

[0089] The container can be provided with a lock 117 that prevents access to the pharmaceuticals in the container by providing a tamperproof seal. Another lock 117 envisaged prevents the rotation of the container gear 114 / sprocket 111 assembly until the container 109 will be used. Even if the dispensing opening 116 is accessible, the sprocket 111 being locked ensures that no carrier 106 can be retrieved from the container 1009 until the lock 117 is removed. Removal of the lock 117 can be detected and the container 109 can be rejected based on potential tampering.

[0090] Figure 12 shows the front view of the cross section A-A indicated in figure of figure 11. It show the possible positioning of the Axle 115, sprocket 111, container gear 114 and lock 117, and also indicates the electric motor 112 and the engagement between the drive gear 112 and the container gear 114.

[0091] Figure 13 shows a closed loop system in which the information cards are used.

[0092] The closed loop system comprises 6 states.

At state 1 the physician writes a prescription for patient A. At state 2 the pharmacist checks the prescription At stage 3 the ward plans the distribution of pharmaceuticals and orders the pharmaceuticals from the pharma-

cist.

At stage 4 the pharmaceutical is packaged, for instance using the information cards of the present invention. The corresponding data, such as patient information and prescription information is stored in a data base on a server. At stage 5 the member of the medical staff takes the pharmaceuticals to the patient.

At stage 6 the administering is registered using a barcode (or RFID means), linking administered pharmaceutical and patient and verifying using the data base whether the administering is correct.

At stage 7 the correct administering is verified by comparing data in the database to the data obtained during the administering of the pharmaceutical.

[0093] Consequently the process of prescribing and administering drug, i.e. pharmaceuticals forms a closed loop including verification.

The loop is closed by feedback about the administering to the database.

As an extension of this, the feedback information in the database is also available to the physician and the pharmacist, allowing further verification that the process was executed correctly. This enhances the safety of the administering process.

Instead of pharmaceuticals, other small packaged items can be attached to the information card of the present invention. Small electronic parts are often provided by the manufacturer on large rolls comprising thousands of parts. This may be satisfactory for use in large scale assembly but is very cumbersome for use in a development laboratory environment. The labeling on the components are very small or even absent while the blister in which they are packaged is also too small for part numbers, resulting in only the spool carrying the data about the type of component. The information card of the present invention allows an appropriate labeling of small quantities of components and at the same time allows the components to be retrieved from the blister cavity in the usual manner.

Claims

1. A method of applying additional information to a pharmaceutical (4) sealed in cavity (3) of a blister (2), wherein the blister (2) is a monoblister having precisely one single cavity (3) that contains a single dose of the pharmaceutical (4), the monoblister (2) having an outer edge (5), a first surface (33) and a second surface (30), the first surface (33) being designed to exercise force on the pharmaceutical (4) to expel the pharmaceutical (4) through the second surface (30), and wherein the method comprises the step of:

providing an individual information card (12) having precisely one blister reception opening (13) and a labelling area (15), wherein the rim around the blister reception opening (13) is pro-

vided with an adhesive (31);
aligning the blister cavity (3) with the blister reception opening (13) of the information card (12), so that there is some overlap between the rim around the blister reception opening (13) and the area of the monoblister between its outer edge (5) and the cavity (3);
attaching the information card (12) to the thus aligned monoblister (2);
and wherein the monoblister is obtained by:

providing a multi-dose blister (1) with multiple cavities (3) containing respective individually packed doses of the pharmaceutical;
dividing the multi-dose blister (1) into a plurality of blister subsections (2), each blister subsection (2) being a monoblister having precisely one single cavity (3) that contains a single dose of the pharmaceutical (4)

and wherein the information card (12) is **either** exclusively attached to the second surface (30) of the monoblister (2), **or** wherein the cavity (3) is placed in the opening (13) and the information card (12) is exclusively attached to the first surface (33) of the monoblister (2);
wherein one surface of the monoblister (2) contains printed information, and wherein the labelling area (15) of the information card (12) carries information at that side where the information on the monoblister (2) is visible; **characterised in that** the labelling area (15) of the information card (12) is provided with a label (32), wherein the label (32) is affixed with an adhesive that allows removal of the label, at a location such that the pharmaceutical (4) can not be expelled without damaging the label (32).

2. A method according to claim 1, wherein the step of aligning the blister cavity (3) with the blister reception opening (13) of the information card (12) is performed with a pick-and-place machine.

3. Assembly of an information card (12) and a blister (2) having a cavity (3) holding a pharmaceutical (4), **characterized in that** the blister is a monoblister having precisely one single cavity (3) that contains a single dose of the pharmaceutical (4), the monoblister (2) having an outer edge (5), a first surface (33) and a second surface (30), the first surface (33) being designed to exercise force on the pharmaceutical (4) to expel the pharmaceutical (4) through the second surface (30);
the information card is an individual information card (12) having precisely one blister reception opening (13) and a labelling area (15)], wherein the rim around the blister reception opening (13) is provided

with an adhesive (31);
 wherein the blister cavity (3) is aligned with the blister reception opening (13) of the information card (12), so that there is some overlap between the rim around the blister reception opening (13) and the area of the monoblister between its outer edge (5) and the cavity (3);
 wherein the area of the monoblister between the outer edge (5) and the cavity (3) is attached to the rim area around said blister reception opening (13) in the information card;
 and wherein the monoblister is obtained by:

providing a multi-dose blister (1) with multiple cavities (3) containing respective individually packed doses of the pharmaceutical;
 dividing the multi-dose blister (1) into a plurality of blister subsections (2), each blister subsection (2) being a monoblister having precisely one single cavity (3) that contains a single dose of the pharmaceutical (4);

and wherein the information card (12) is **either** exclusively attached to the second surface (30) of the monoblister (2), **or** wherein the cavity (3) is placed in the opening (13) and the information card (12) is exclusively attached to the first surface (33) of the monoblister (2);

wherein one surface of the monoblister (2) contains printed information, and wherein the labelling area (15) of the information card (12) carries information at that side where the information on the monoblister (2) is visible; **characterised in that** the labelling area (15) of the information card (12) is provided with a label (32), wherein the label (32) is affixed with an adhesive that allows removal of the label, at a location such that the pharmaceutical (4) can not be expelled without damaging the label (32).

4. Assembly according to claim 3, wherein the information card comprises a barcode or the information card comprises an RFID device.

Patentansprüche

1. Verfahren zum Anbringen von zusätzlichen Informationen an einem Arzneimittel (4), das in einem Hohlraum (3) eines Blisters (2) versiegelt ist, wobei der Blister ein Monoblister (2) ist, der genau einen einzelnen Hohlraum (3) aufweist, der eine einzelne Dosis des Arzneimittels (4) enthält, wobei der Monoblister (2) eine äußere Kante (5), eine erste Oberfläche (33) und eine zweite Oberfläche (30) aufweist, wobei die erste Oberfläche (33) dafür ausgelegt ist, auf das Arzneimittel (4) eine Kraft auszuüben, um das Arzneimittel (4) durch die zweite Oberfläche (30) hindurch auszustoßen,

und wobei das Verfahren die folgenden Schritte umfasst:

Bereitstellen einer einzelnen Informationskarte (12), die genau eine Blisteraufnahmeöffnung (13) und einen Kennzeichnungsbereich (15) aufweist, wobei der Rand um die Blisteraufnahmeöffnung (13) mit einem Klebstoff (31) versehen ist;

Ausrichten des Blisterhohlraums (3) auf die Blisteraufnahmeöffnung (13) der Informationskarte (12), so dass es eine gewisse Überlappung zwischen dem Rand um die Blisteraufnahmeöffnung (13) und dem Bereich des Monoblisters zwischen seiner äußeren Kante (5) und dem Hohlraum (3) gibt;

Befestigen der Informationskarte (12) an dem auf diese Weise ausgerichteten Monoblister (2); und wobei der Monoblister durch Folgendes erhalten wird:

Bereitstellen eines Multi-Dosisblisters (1) mit mehrfachen Hohlräumen (3), die die jeweiligen einzeln verpackten Dosen des Arzneimittels enthalten;

Teilen des Multi-Dosisblisters (1) in mehrere Blisterunterabschnitte (2), wobei jeder Blisterunterabschnitt (2) ein Monoblister mit genau einem einzelnen Hohlraum (3) ist, der eine Einzeldosis des Arzneimittels (4) enthält,

und wobei die Informationskarte (12) **entweder** ausschließlich an der zweiten Oberfläche (30) des Monoblisters (2) befestigt wird, **oder** wobei der Hohlraum (3) in der Öffnung (13) angeordnet wird und wobei die Informationskarte (12) ausschließlich an der ersten Oberfläche (33) des Monoblisters (2) befestigt wird;

wobei eine Oberfläche des Monoblisters (2) gedruckte Informationen enthält, und wobei der Kennzeichnungsbereich (15) der Informationskarte (12) Informationen an der Seite trägt, an der Informationen auf dem Monoblister (2) sichtbar sind;

dadurch gekennzeichnet, dass der Kennzeichnungsbereich (15) der Informationskarte (12) mit einer Kennzeichnung (32) versehen ist, wobei die Kennzeichnung (32) mit einem Klebstoff, der eine Entfernung der Kennzeichnung ermöglicht, an einem Ort derart befestigt wird, dass das Arzneimittel (4) nicht ohne Beschädigung der Kennzeichnung (32) ausgestoßen werden kann.

2. Verfahren nach Anspruch 1, wobei der Schritt des Ausrichtens des Blisterhohlraums (3) auf die Blisteraufnahmeöffnung (13) der Informationskarte (12) mit

einem Bestückungsmaschine durchgeführt wird.

3. Anordnung einer Informationskarte (12) und eines Blisters (2) mit einem Hohlraum (3), der ein Arzneimittel (4) aufnimmt und hält, **dadurch gekennzeichnet, dass**

der Blister ein Monoblister ist, der genau einen einzelnen Hohlraum (3) aufweist, der eine einzelne Dosis des Arzneimittels (4) enthält, wobei der Monoblister (2) eine äußere Kante (5), eine erste Oberfläche (33) und eine zweite Oberfläche (30) aufweist, wobei die erste Oberfläche (33) dafür ausgelegt ist, auf das Arzneimittel (4) eine Kraft auszuüben, um das Arzneimittel (4) durch die zweite Oberfläche (30) hindurch auszustoßen;

die Informationskarte eine einzelne Informationskarte (12) ist, die genau eine Blisteraufnahmeöffnung (13) und einen Kennzeichnungsbereich (15)] aufweist, wobei der Rand um die Blisteraufnahmeöffnung (13) mit einem Klebstoff (31) versehen ist; wobei der Blisterhohlraum (3) auf die Blisteraufnahmeöffnung (13) der Informationskarte (12) ausgerichtet wird, so dass es eine gewisse Überlappung zwischen dem Rand um die Blisteraufnahmeöffnung (13) und dem Bereich des Monoblister zwischen seiner äußeren Kante (5) und dem Hohlraum (3) gibt; wobei der Bereich des Monoblister zwischen der äußeren Kante (5) und dem Hohlraum (3) an dem Randbereich um die Blisteraufnahmeöffnung (13) in der Informationskarte befestigt wird; und wobei der Monoblister durch Folgendes erhalten wird:

Bereitstellen eines Multi-Dosisblisters (1) mit mehrfachen Hohlräumen (3), die die jeweiligen einzeln verpackten Dosen des Arzneimittels enthalten;

Teilen des Multi-Dosisblisters (1) in mehrere Blisterunterabschnitte (2), wobei jeder Blisterunterabschnitt (2) ein Monoblister mit genau einem einzelnen Hohlraum (3) ist, der eine Einzeldosis des Arzneimittels (4) enthält;

und wobei die Informationskarte (12) **entweder** ausschließlich an der zweiten Oberfläche (30) des Monoblister (2) befestigt wird, **oder** wobei der Hohlraum (3) in der Öffnung (13) angeordnet wird und wobei die Informationskarte (12) ausschließlich an der ersten Oberfläche (33) des Monoblister (2) befestigt wird;

wobei eine Oberfläche des Monoblister (2) gedruckte Informationen enthält, und wobei der Kennzeichnungsbereich (15) der Informationskarte (12) Informationen an der Seite trägt, an der Informationen auf dem Monoblister (2) sichtbar sind;

dadurch gekennzeichnet, dass der Kennzeichnungsbereich (15) der Informationskarte (12) mit einer Kennzeichnung (32) versehen ist, wobei die

Kennzeichnung (32) mit einem Klebstoff, der eine Entfernung der Kennzeichnung ermöglicht, an einem Ort derart befestigt wird, dass das Arzneimittel (4) nicht ohne Beschädigung der Kennzeichnung (32) ausgestoßen werden kann.

4. Anordnung nach Anspruch 3, wobei die Informationskarte einen Barcode umfasst oder wobei die Informationskarte eine RFID-Vorrichtung umfasst.

Revendications

1. Procédé pour apporter des informations supplémentaires sur un produit pharmaceutique (4) enfermé hermétiquement dans une cavité (3) d'une coque (2), la coque (2) étant une coque unique comportant exactement une seule cavité (3) qui contient une dose unique du produit pharmaceutique (4), la coque unique (2) comportant un bord extérieur (5), une première surface (33) et une deuxième surface (30), la première surface (33) étant conçue pour appliquer une force sur le produit pharmaceutique (4) de manière à expulser le produit pharmaceutique (4) à travers la deuxième surface (30), et le procédé comportant l'étape qui consiste à :

prendre une carte individuelle d'information (12) qui présente exactement une ouverture (13) de réception de coque et une zone d'étiquetage (15), le bord entourant l'ouverture (13) de réception de coque étant doté d'un adhésif (31) ; aligner la cavité (3) de la coque sur l'ouverture (13) de réception de coque de la carte d'information (12) de manière à obtenir une certaine superposition entre le bord entourant l'ouverture (13) de réception de coque et la zone de la coque unique située entre son bord extérieur (5) et la cavité (3) ; fixer la carte d'information (12) à la coque unique (2) ainsi alignée ; et la coque unique étant obtenue en :

prenant une coque multidose (1) comportant une pluralité de cavités (3) contenant des doses emballées individuellement respectives du produit pharmaceutique ; divisant la coque multidose (1) en une pluralité de sous-sections de coque (2), chaque sous-section de coque (2) constituant une coque unique comportant précisément une seule cavité (3) qui contient une dose unique du produit pharmaceutique (4) ;

et la carte d'information (12) étant exclusivement fixée à la deuxième surface (30) de la coque unique (2), **ou** la cavité (3) étant placée dans l'ouverture (13) et la carte d'information (12)

- étant exclusivement fixée à la première surface (33) de la coque unique (2) ;
 une surface de la coque unique (2) contenant des informations imprimées,
 et la zone d'étiquetage (15) de la carte d'information (12) présentant des informations sur le côté sur lequel les informations présentes sur la coque unique (2) sont visibles ;
caractérisé en ce que la zone d'étiquetage (15) de la carte d'information (12) est dotée d'une étiquette (32), l'étiquette (32) étant collée au moyen d'un adhésif qui permet le retrait de l'étiquette, au niveau d'un emplacement tel que le produit pharmaceutique (4) ne peut être expulsé sans endommager l'étiquette (32).
2. Procédé selon la revendication 1, l'étape d'alignement de la cavité (3) de la coque sur l'ouverture (13) de réception de coque de la carte d'information (12) étant exécutée à l'aide d'une machine de saisie et de positionnement.
3. Ensemble constitué d'une carte d'information (12) et d'une coque (2) comportant une cavité (3) qui contient un produit pharmaceutique (4), **caractérisé en ce que** la coque est une coque unique comportant exactement une seule cavité (3) qui contient une dose unique du produit pharmaceutique (4), la coque unique (2) comportant un bord extérieur (5), une première surface (33) et une deuxième surface (30), la première surface (33) étant conçue pour appliquer une force sur le produit pharmaceutique (4) de manière à expulser le produit pharmaceutique (4) à travers la deuxième surface (30), la carte d'information est une carte individuelle d'information (12) qui présente exactement une ouverture (13) de réception de coque et une zone d'étiquetage (15), le bord entourant l'ouverture (13) de réception de coque étant doté d'un adhésif (31) ;
 la cavité (3) de la coque étant alignée sur l'ouverture (13) de réception de coque de la carte d'information (12) de manière à obtenir une certaine superposition entre le bord entourant l'ouverture (13) de réception de coque et la zone de la coque unique située entre son bord extérieur (5) et la cavité (3) ;
 la zone de la coque unique située entre le bord extérieur (5) et la cavité (3) étant fixée à la zone de bord située autour de ladite ouverture (13) de réception de coque dans la carte d'information ;
 et la coque unique étant obtenue en :
- prenant une coque multidose (1) comportant une pluralité de cavités (3) contenant des doses emballées individuellement respectives du produit pharmaceutique ;
 divisant la coque multidose (1) en une pluralité de sous-sections de coque (2), chaque sous-

- section de coque (2) constituant une coque unique comportant précisément une seule cavité (3) qui contient une dose unique du produit pharmaceutique (4) ;
- et la carte d'information (12) étant exclusivement fixée à la deuxième surface (30) de la coque unique (2), ou la cavité (3) étant placée dans l'ouverture (13) et la carte d'information (12) étant exclusivement fixée à la première surface (33) de la coque unique (2) ;
 une surface de la coque unique (2) contenant des informations imprimées, et la zone d'étiquetage (15) de la carte d'information (12) présentant des informations sur le côté sur lequel les informations présentes sur la coque unique (2) sont visibles ;
caractérisé en ce que la zone d'étiquetage (15) de la carte d'information (12) est dotée d'une étiquette (32), l'étiquette (32) étant collée au moyen d'un adhésif qui permet le retrait de l'étiquette, au niveau d'un emplacement tel que le produit pharmaceutique (4) ne peut être expulsé sans endommager l'étiquette (32).
4. Ensemble selon la revendication 3, la carte d'information comprenant un code à barres ou la carte d'information comprenant un dispositif d'identification par radiofréquence.

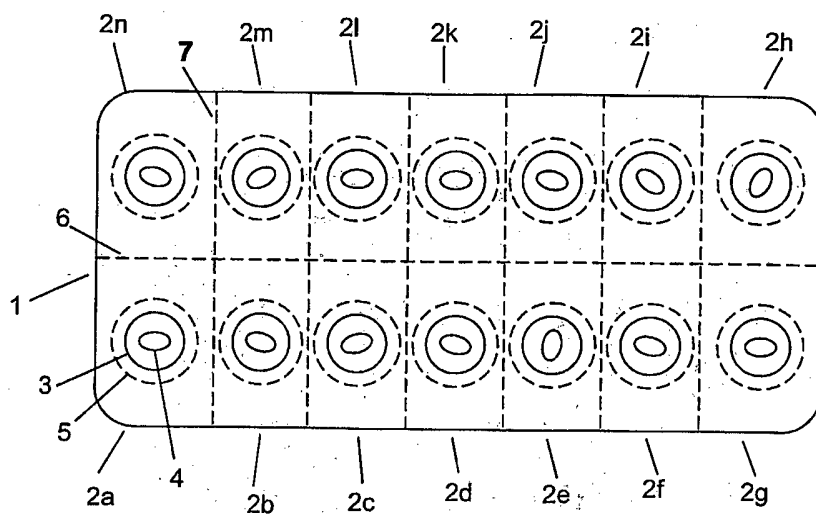

Fig. 1

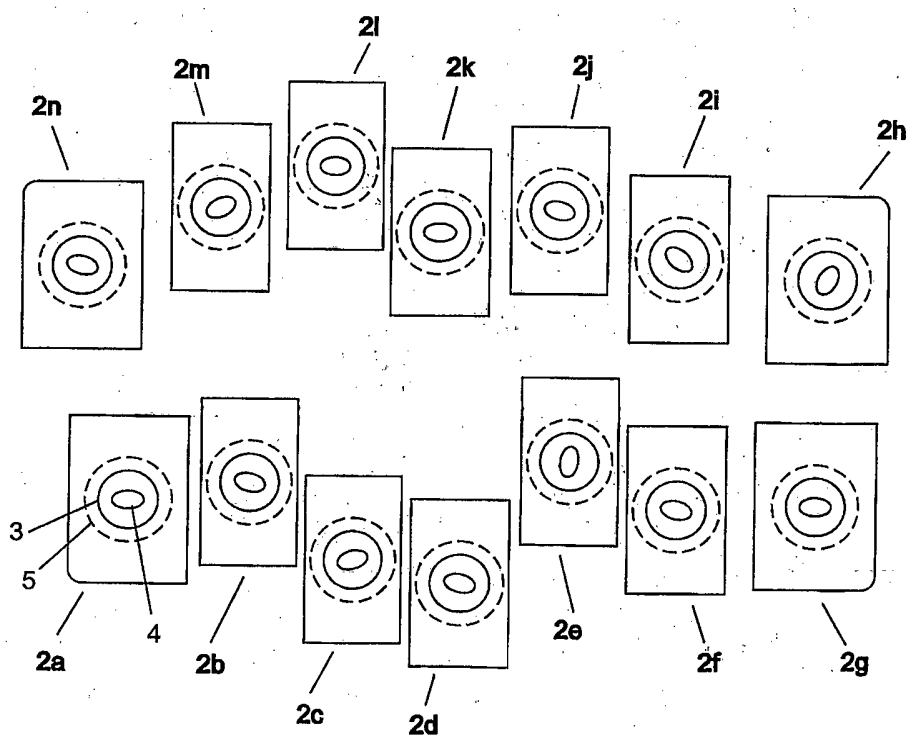

Fig. 2

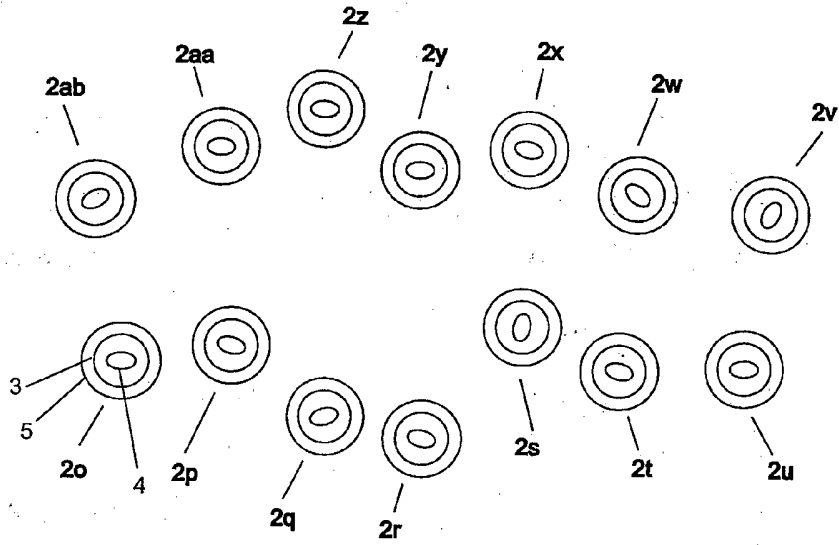

Fig. 3

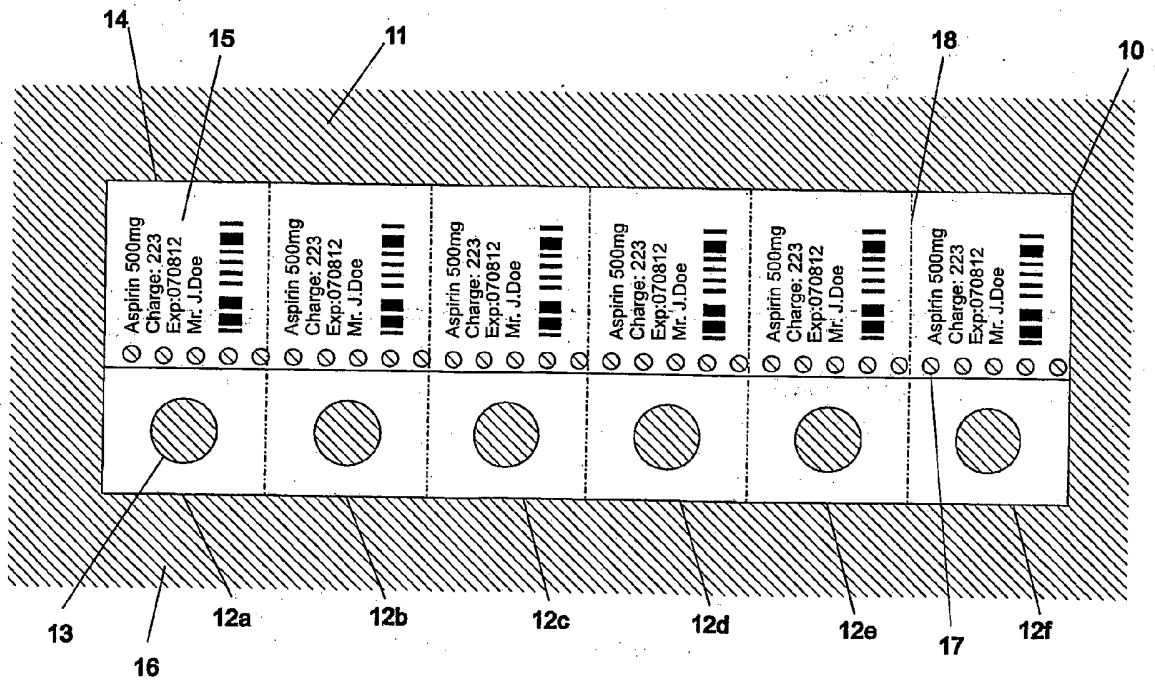

Fig. 4

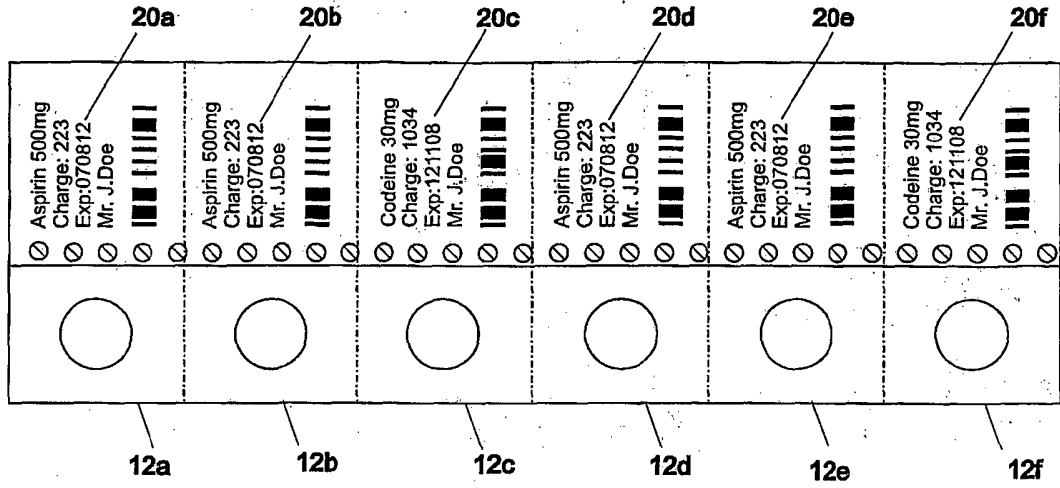

Fig. 5

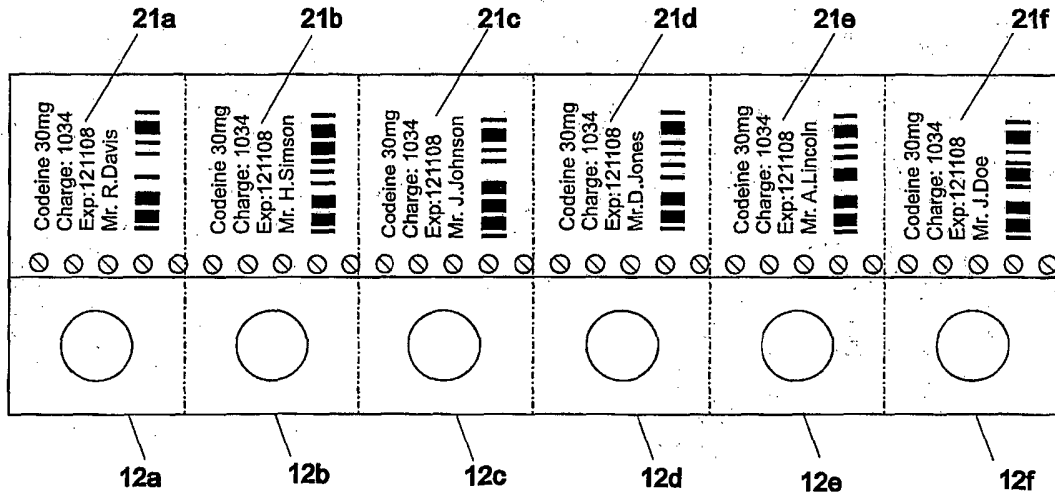

Fig. 6

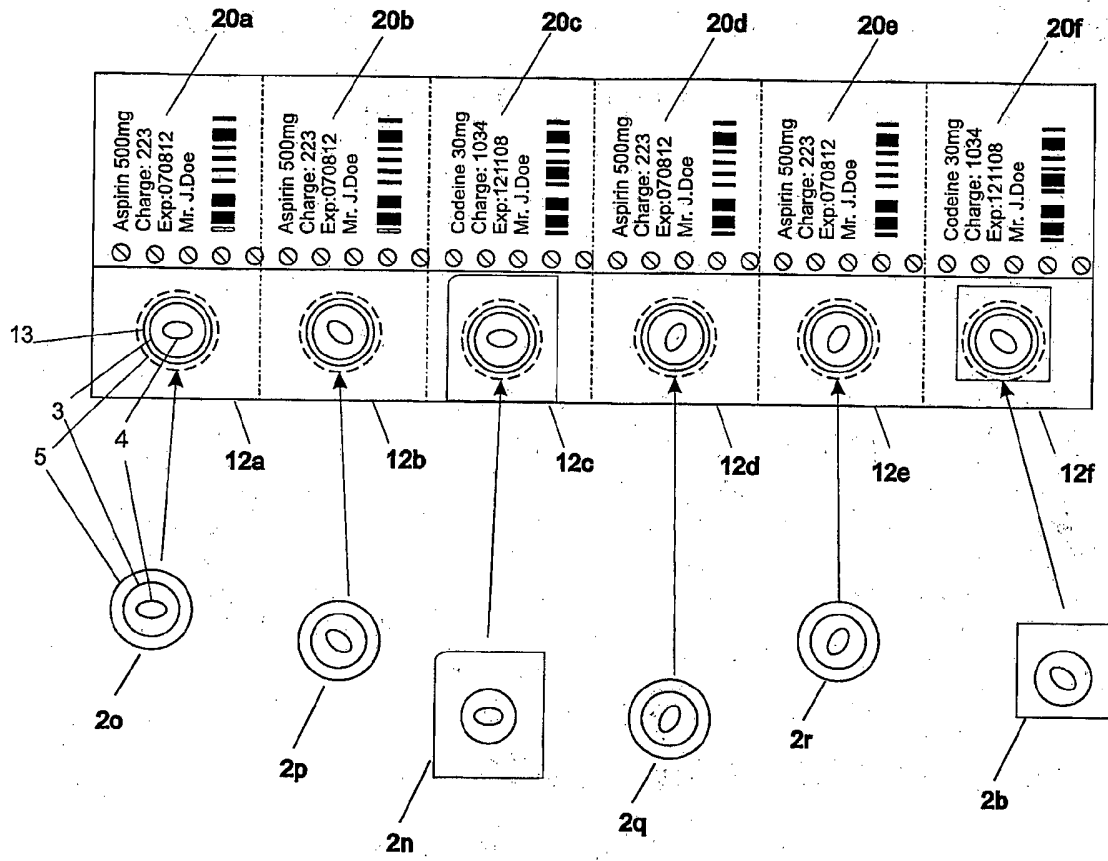

Fig. 7

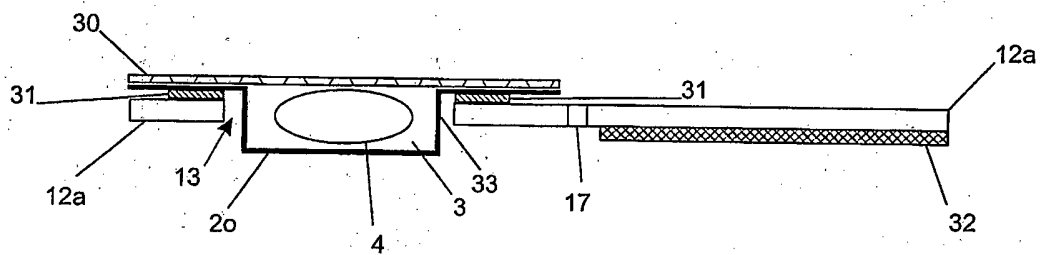

Fig. 8

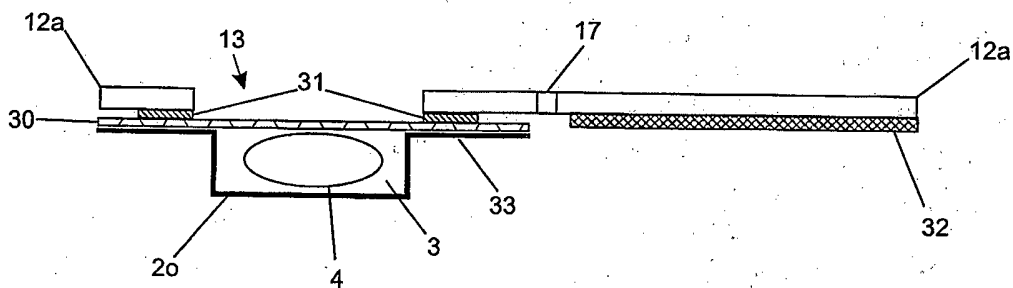

Fig. 9

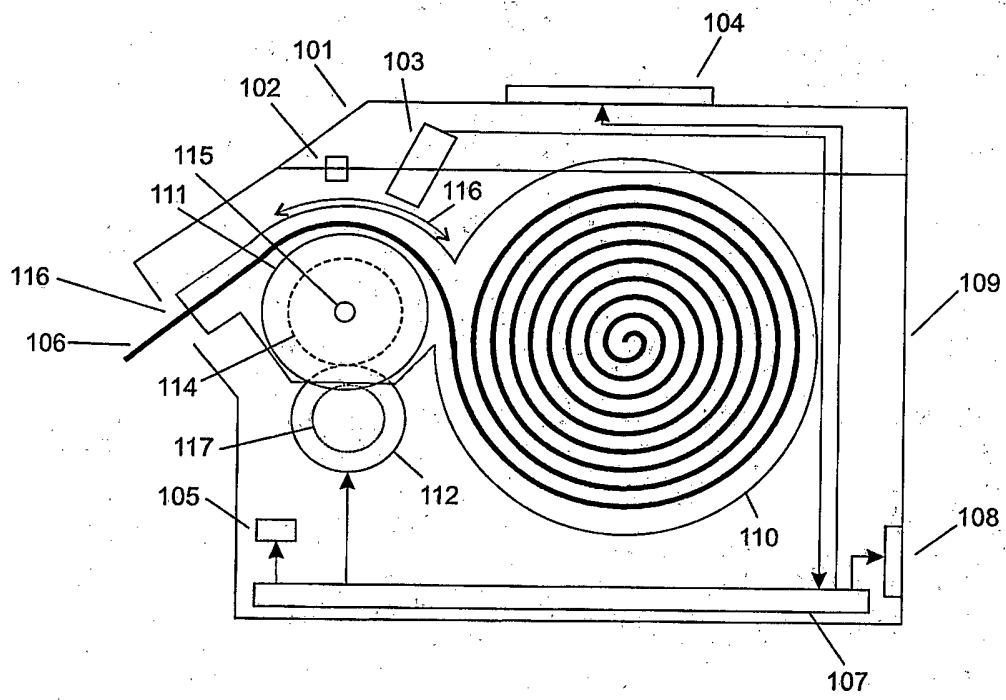

Fig. 10

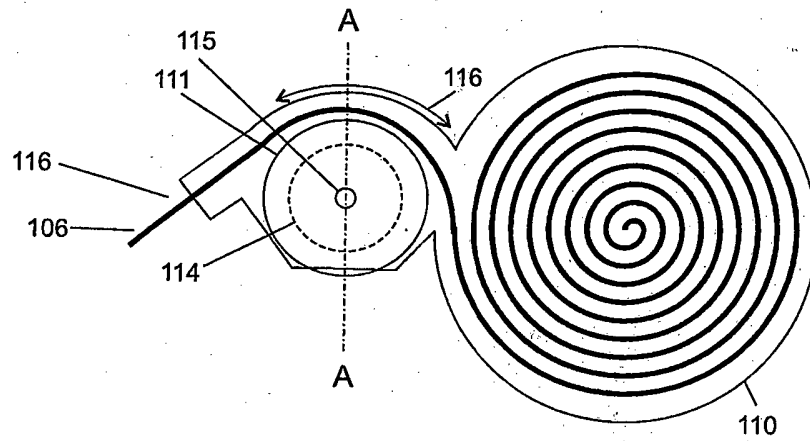

Fig. 11

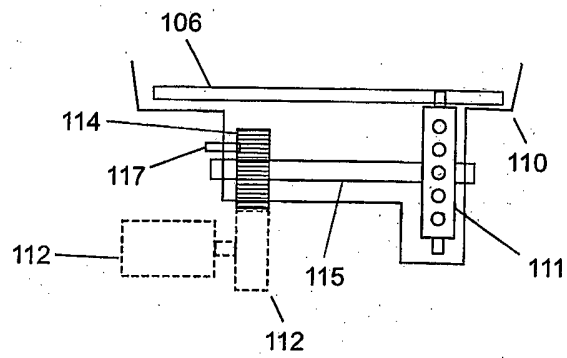

Fig. 12

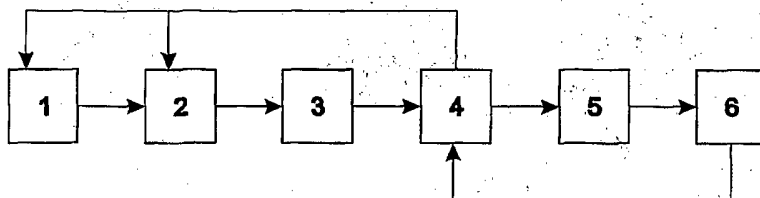

Fig. 13

REFERENCES CITED IN THE DESCRIPTION

This list of references cited by the applicant is for the reader's convenience only. It does not form part of the European patent document. Even though great care has been taken in compiling the references, errors or omissions cannot be excluded and the EPO disclaims all liability in this regard.

Patent documents cited in the description

- US 4362000 A [0002]
- US 1816542 A [0002]

714549/DO

INFORMÁCIÓS KÁRTYÁNAK EGY BUBORÉKFÓLIÁBA CSOMAGOLT TÁRGYHOZ VALÓ
CSATLAKOZTATÁSÁRA SZOLGÁLÓ ELJÁRÁS, INFORMÁCIÓS KÁRTYA, VALAMINT AZ
INFORMÁCIÓS KÁRTYÁT HASZNÁLÓ RENDSZER

SZABADALMI IGÉNYPONTOK

1. Eljárás kiegészítő információk hozzáadására egy buborék (2) üregébe (3) zárt gyógyszerkészítményhez (4),

amely buborék (2) egy egyesbuborék, amelynek pontosan egyetlen ürege (3) van, amely egyetlen adag gyógyszerkészítményt (4) tartalmaz, az egyesbuboréknak (2) van egy külső szegélye (5), egy első felülete (33) és egy második felülete (30), az első felület (33) úgy van kialakítva, hogy erőt gyakoroljon a gyógyszerkészítményre (4) a gyógyszerkészítménynek (4) a második felületen (30) keresztül történő kilökése céljából,

továbbá az eljárás magában foglalja azt a lépést, hogy:

kialakítunk egy egyedi információs kártyát (12), amely rendelkezik pontosan egy buborékbefogadó nyílással (13) és egy címkézési területtel (15), amely buborékbefogadó nyílás (13) körül a perem ragasztóval (31) van ellátva;

hozzáigazítjuk a buboréküreget (3) az információs kártya (12) buborékbefogadó nyílásához (13) úgy, hogy átfedés van a buborékbefogadó nyílás (13) körüli perem és az egyesbuboréknak a külső szegélye (5) és az ürege (3) közötti területe között;

csatlakoztatjuk az információs kártyát (12) az így beigazított egyesbuborékhoz (2);

azonkívül az egyesbuboréket úgy kapjuk, hogy:

kialakítunk egy több üreggel (3) rendelkező, többadagos buboréket (1), amely üregek a gyógyszerkészítmény külön-külön csomagolt adagjait tartalmazzák;

felosztjuk a többadagos buboréket (1) több buborékos alrészre (2), mindegyik buborékos alrész (2) egy olyan egyesbuborék, amelynek pontosan egyetlen ürege (3) van, amely egyetlen adag gyógyszerkészítményt (4) tartalmaz;

azonkívül az információs kártya (12) vagy kizárólag az egyesbuborék (2) második felületéhez (30) van csatlakoztatva, vagy egy üreg (3) van elhelyezve a nyílásban (13), és az információs kártya (12) kizárólag az egyesbuborék (2) első felületéhez (33) van csatlakoztatva;

azonkívül az egyesbuborék (2) egyik felülete nyomtatott információt tartalmaz, és az információs kártya (12) címkézési területe (15) azon az oldalon hordozza az információkat, ahol az egyesbuborékon (2) lévő információk láthatók;

azzal jellemezve, hogy az információs kártya (12) címkézési területe (15) el van

látva egy címkével (32), amely címke (32) a címke eltávolítását lehetővé tevő ragasztóval van rögzítve egy olyan helyen, hogy a gyógyszerkészítmény (4) nem vehető ki a címke (32) károsítása nélkül.

2. Az 1. igénypont szerinti eljárás, amelynél azt a lépést, amelyben hozzáigazítjuk a buboréküreget (3) az információs kártya (12) buborékbefogadó nyílásához (13), beültető (pick-and-place) géppel hajtjuk végre.

3. Egység, amely egy információs kártyából (12) és egy olyan buborékból (2) áll, amelynek van egy gyógyszerkészítményt (4) tartó ürege (3), azzal jellemezve, hogy

a buborék egy egyesbuborék, amelynek pontosan egyetlen ürege (3) van, amely egyetlen adag gyógyszerkészítményt (4) tartalmaz, az egyesbuboréknak (2) van egy külső szegélye (5), egy első felülete (33) és egy második felülete (30), az első felület (33) úgy van kialakítva, hogy erőt gyakoroljon a gyógyszerkészítményre (4) a gyógyszerkészítménynek (4) a második felületen (30) keresztül történő kilökése céljából;

az információs kártya egy egyedi információs kártya (12), amely rendelkezik pontosan egy buborékbefogadó nyílással (13) és egy címkézési területtel (15), amely buborékbefogadó nyílás (13) körül a perem ragasztóval (31) van ellátva;

továbbá a buboréküreg (3) hozzá van igazítva az információs kártya (12) buborékbefogadó nyílásához (13) úgy, hogy átfedés van a buborékbefogadó nyílás (13) körüli perem és az egyesbuboréknak a külső szegélye (5) és az ürege (3) közötti területe között;

azonkívül az egyesbuboréknak a külső szegély (5) és az üreg (3) közötti területe csatlakoztatva van az információs kártyában lévő buborékbefogadó nyílás (13) körüli peremrészhez;

és az egyesbuborék úgy jön létre, hogy:

kialakítunk egy több üreggel (3) rendelkező, többadagos buborékot (1), amely üregek a gyógyszerkészítmény külön-külön csomagolt adagjait tartalmazzák;

a többadagos buborék (1) felosztásra kerül több buborékos alrészre (2), mindegyik buborékos alrész (2) egy olyan egyesbuborék, amelynek pontosan egyetlen ürege (3) van, amely egyetlen adag gyógyszerkészítményt (4) tartalmaz;

azonkívül az információs kártya (12) vagy kizárólag az egyesbuborék (2) második felületéhez (30) van csatlakoztatva, vagy egy üreg (3) van elhelyezve a nyílásban (13), és az információs kártya (12) kizárólag az egyesbuborék (2) első felületéhez (33) van csatlakoztatva;

azonkívül az egyesbuborék (2) egyik felülete nyomtatott információt tartalmaz, és az információs kártya (12) címkézési területe (15) azon az oldalon hordozza az információkat, ahol az egyesbuborékon (2) lévő információk láthatók;

azzal jellemezve, hogy az információs kártya (12) címkézési területe (15) el van látva egy címkével (32), amely címke (32) a címke eltávolítását lehetővé tevő

ragasztóval van rögzítve egy olyan helyen, hogy a gyógyszerkészítmény (4) nem vehető ki a címke (32) károsítása nélkül.

4. A 3. igénypont szerinti egység, amelyben az információs kártya magában foglal egy vonalkódot, vagy az információs kártya magában foglal egy rádiófrekvenciás azonosító eszközt (RFID).

(A meghatalmazott)

Mészárosné Dónusz Katalin
Gyógyszerügyosztály
NEMK Széchenyi Utcai Iroda
1053 Budapest, Széchenyi út 112.
Telefon: 461-1000 / 461-1099
Email: gyugy@nemk.hu