

E. THUNBERG.

METHOD AND MEANS FOR WORKING ECCENTRICALLY ROTATING PARTS.

APPLICATION FILED DEC. 21, 1907.

923,732.

Patented June 1, 1909.

Fig: 1.

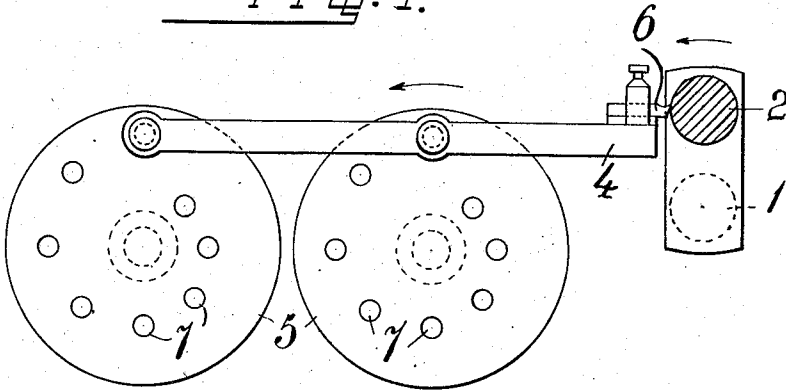
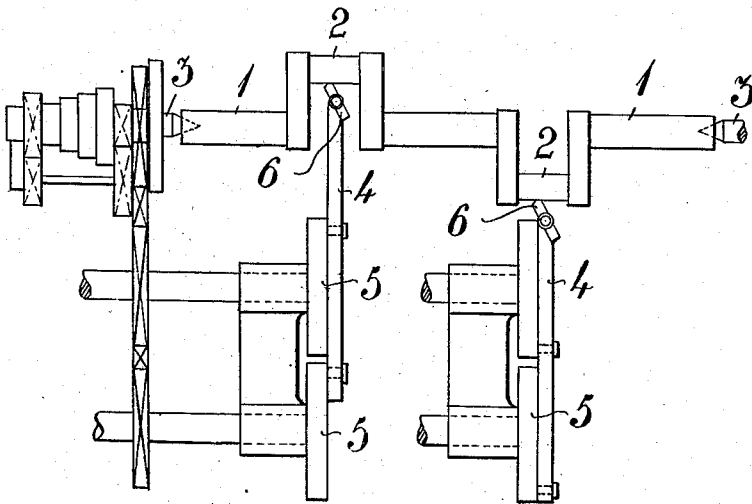

Fig: 2.



WITNESSES

W. P. Burks
W. H. Kennedy

INVENTOR

Einst Thunberg
E. Thunberg

UNITED STATES PATENT OFFICE.

ERNST THUNBERG, OF BOFORS, SWEDEN.

METHOD AND MEANS FOR WORKING ECCENTRICALLY-ROTATING PARTS.

No. 923,732.

Specification of Letters Patent.

Patented June 1, 1909.

Application filed December 21, 1907. Serial No. 407,560.

To all whom it may concern:

Be it known that I, ERNST THUNBERG, mechanical engineer, subject of Sweden, residing at Bofors, in the county of Wermland, Sweden, have invented new and useful Improvements in Means for Working Eccentrically-Rotating Parts, of which the following is a specification.

In working, for instance turning, grinding and polishing eccentrically rotating parts such as the cranks on crank shafts the method hitherto employed has been either, that the shaft has been mounted in a fixed position and the tool been rotated around the crank, or in most cases that on the ends of the shaft have been fixed pieces, that have been mounted between the centers of a lathe so that the axis of the crank has coincided with the axis of said centers whereupon the crank has been turned or ground in the usual manner. This, however, has caused several inconveniences and difficulties. The whole shaft with exception only of the crank being worked will rotate eccentrically with relation to the axis of the centers and thus cause an uneven motion and an extremely inconvenient strain on the machine, this strain being especially important in working large and consequently heavy pieces. The eccentrically rotating masses also will make the working with a great speed difficult, what otherwise would be possible with rapidly cutting steel. A third inconvenience is, that if several cranks are situated on the same shaft only one can be worked at a time. It has also been proposed to mount the shaft in the machine in such a way, that its center-line coincides with that one of the machine, or in the same way as in turning a shaft without cranks, and to provide a milling tool around the crank pin, whereupon the shaft is set in rotation, so that the pin is being cut by the tool, the motion of said tool then being not quite independent and positive but in some way controlled by the pin itself. This method, however, is unpractical, because only the shape of the pin, but not the crank radius thus will be exactly determined by the tool.

According to the present invention, the shaft is mounted in the last mentioned way,

that is, coaxially with the centers, and is worked by a tool that is moved in a vertical and horizontal direction together with the crank-pin, but such motion of the tool in this case is fully and positively determined by a special gear so that the tool can work the rotating part (*e. g.* the pin) in a manner that is not dependent upon the motion of the pin.

The method is illustrated in the accompanying drawing, where it is shown as employed on a shaft with two cranks.

Figure 1 illustrates the device for causing the motion of the tool in elevation and Fig. 2 in a reduced scale the shaft in position together with two working tools.

1 is the shaft, 2 the cranks, 3 the centers of the lathe and 4 the tool-holders, each of which is mounted in the example illustrated in the same way as a connecting-rod on two plates 5, such plates having a rotating motion so adapted, that the tool 6 will describe a circle around the crank-pin during the rotation of the latter. The plates are provided with holes 7 or other securing devices on different distances from the center, so that the motion of the connecting-rods can be varied according to the radius of the crank to be worked. The plates 5 are driven by a suitable gearing from the same source of power as the lathe or grinding machine itself.

Having now particularly described and ascertained the nature of my invention and in what manner the same is performed, I declare that what I claim is:

1. In a device for turning the crank pins of crank shafts and the like, means for supporting the crank shaft, a pair of rotatable elements, arranged in line with each other and said crank pin, a bar, journals connecting the bar with said rotatable elements, a tool carried by the end of the bar in contact with the crank pin to be turned, and means for rotating the crank shaft and said elements synchronously.

2. In a device for turning the crank pins of crank shafts and the like, means for supporting the crank shaft, a pair of rotatable disks arranged in line with each other and said crank pin, a bar, a pair of pivots car-

ried by said bar, said disks having holes therein with which the pivots of the bar are adapted to engage whereby the position of the bar may be adjusted, a tool carried by
5 the end of the bar in contact with the crank pin, and means for rotating the crank shaft and said disks synchronously.

In testimony whereof I have signed my name to this specification in the presence of two subscribing witnesses.

ERNST THUNBERG.

Witnesses:

JOHN EDBERG,
H. TELANDER.