

No. 703,207.

Patented June 24, 1902.

D. KNOWLTON.

COIN CONTROLLED MECHANISM FOR VENDING MACHINES.

(Application filed Jan. 20, 1902.)

(No Model.)

2 Sheets—Sheet 1.

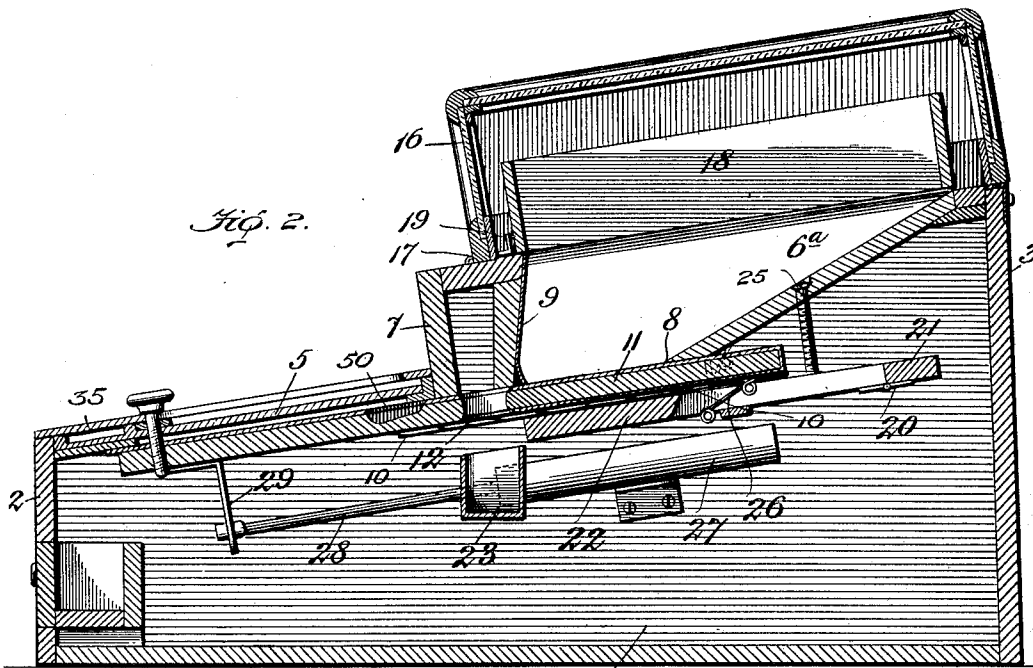
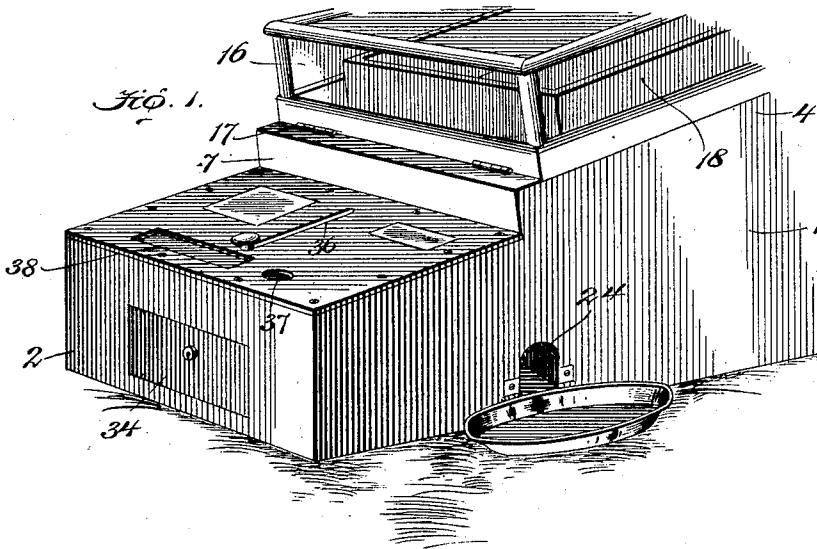

Witnesses:

[Signature]
C. F. Duwall

by

Inventor:

Dallas Knowlton

[Signature]
Attorney

D. KNOWLTON.

COIN CONTROLLED MECHANISM FOR VENDING MACHINES.

(Application filed Jan. 20, 1902.)

(No Model.)

2 Sheets—Sheet 2.

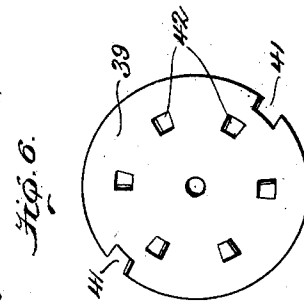
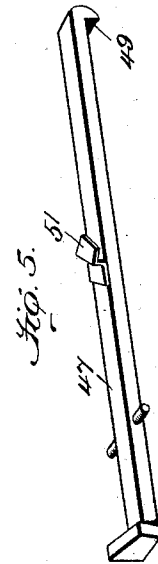
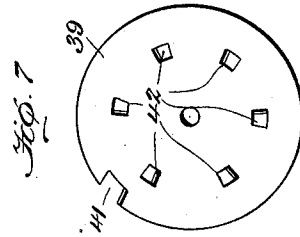
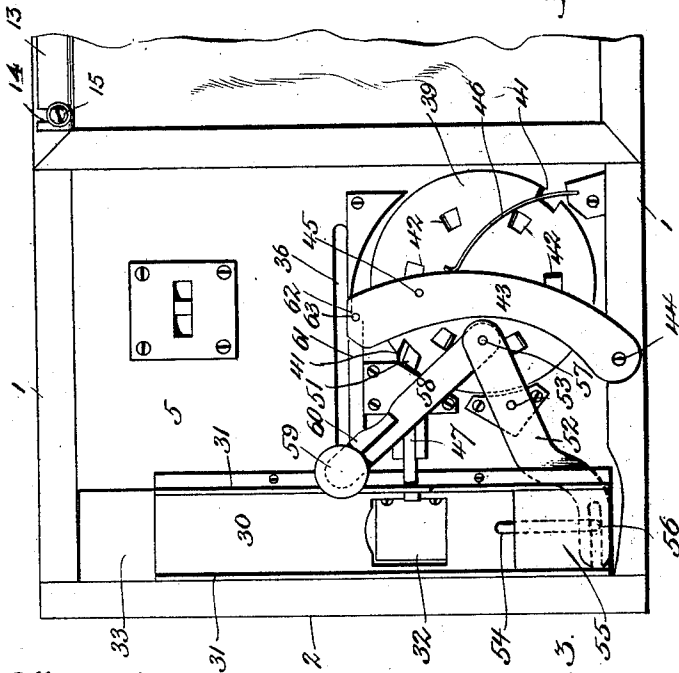
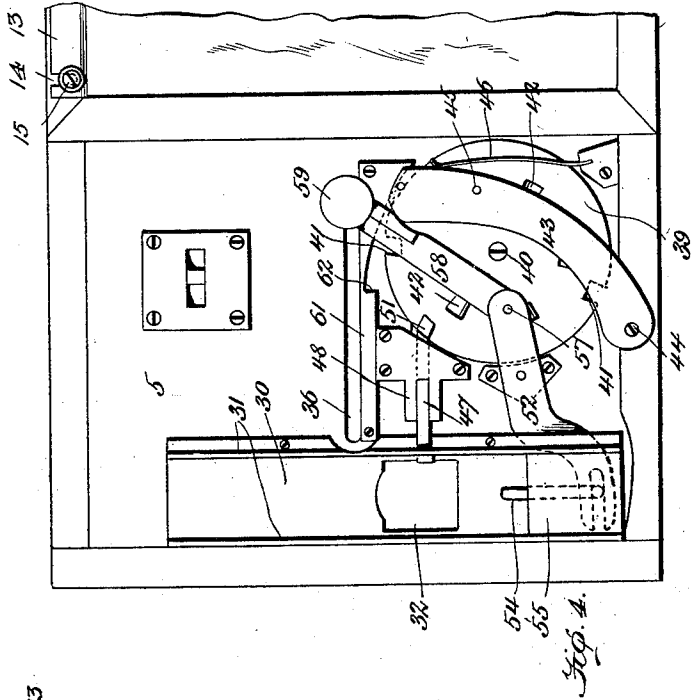

Witnesses:

Wm. C. ...
C. F. Duvall

by Fig. 5.

Inventor:
Dallas Knowlton
M. Duvall
 Attorney

UNITED STATES PATENT OFFICE.

DALLAS KNOWLTON, OF WASHINGTON, DISTRICT OF COLUMBIA.

COIN-CONTROLLED MECHANISM FOR VENDING-MACHINES.

SPECIFICATION forming part of Letters Patent No. 703,207, dated June 24, 1902.

Application filed January 20, 1902. Serial No. 90,503. (No model.)

To all whom it may concern:

Be it known that I, DALLAS KNOWLTON, a citizen of the United States, residing at Washington, District of Columbia, have invented 5 new and useful Improvements in Coin-Controlling Mechanisms for Vending-Machines, of which the following is a specification.

This invention relates to improvements in coin-controlled mechanisms for vending-ma- 10 chines.

The main objects of the invention are to provide a simple, efficient, and positive coin-controlled mechanism, the same being adapted to permit of one or a plurality of succes- 15 sive operations of the delivery devices, whereby for the single coin introduced into the machine a given number of articles may be vend- ed or delivered before the delivery devices are again locked.

I have illustrated the invention in connec- 20 tion with a vending apparatus forming the subject-matter of a contemporaneously-pending application—to wit, Serial No. 61,099, filed May 20, 1901—which is primarily intended for 25 the vending of cigars; but it is to be understood that the present invention is not to be limited to the application shown, but may be used in connection with other vending-machines that deliver by the operation of a slide 30 or its equivalent.

Other objects and advantages of the inven- tion will hereinafter appear, and the novel features of the same will be particularly point- ed out and claimed.

Referring to the drawings, Figure 1 is a per- 35 spective view of the front portion of a vend- ing-machine employing my coin-controlled mechanism. Fig. 2 is a longitudinal central section of the same. Fig. 3 is a plan view of 40 the machine with the cover-plate removed, showing the coin-controlled mechanism as the same appears when the machine is locked. Fig. 4 is a similar view showing the parts in the position they assume after the introduc- 45 tion of a coin and an upward movement of the free end of the operating-lever. Figs. 5, 6, and 7 are details of parts hereinafter referred to.

Similar numerals of reference indicatesimi- 50 lar parts in all the figures of the drawings.

The machine when viewed in plan is of a general oblong shape and comprises opposite

side walls 1, preferably inclined toward their rear edges, as shown, and from about their middles being slightly and abruptly elevated, 55 as indicated at 4, thereby forming the side walls of a superimposed hopper 6. As will hereinafter appear, the hopper 6 contains the articles to be vend- ed. The frame of the machine also comprises the front wall 2 and the 60 rear wall 3. A platform 5, supported by the side walls 1 and front wall 2, supports the coinway and coin-controlled and tripping mechanisms hereinafter described.

Located in the hopper 6 is an inclined feed- 65 bottom 6^a, which extends possibly a little over one-half the distance from the rear wall 3 toward a transverse front wall 7, that connects the two side walls of the hopper 6. The feed-bottom, as before stated, is inclined, 70 and terminating, as it does, short of the wall 7, combines with the latter to produce a feed-open- ing 8, the adjacent edge of the feed-opening being beveled on its under side, as shown. The front end of this feed-opening is formed 75 by what may be termed a "fixed" cut-off 9, the lower edge of which is substantially in line with the beveled edge of the feed-bottom, and said cut-off may be vertical and straight in cross-section or inclined and curved slightly, 80 the latter being preferable for reasons hereinafter apparent.

Below the bottom of the feed-opening of the hopper 6 and the platform 5 and in close 85 proximity to the former and in opposite paral- lel inclined ways 10, affixed to the side walls 1, is a sliding cut-off 11, the same being provided with a transverse delivery slot or slots 12, the upper edges of which may be slightly 90 rounded. The delivery-slot may be, but prefer- ably is not, made adjustable in width; but in the latter event, as herein, is of a width sufficient to cause it to readily receive the largest size (in diameter) of merchantable 95 articles the machine will be called upon to vend—as, for instance, a cigar. Also the length of the slot is such as will adapt it to readily accommodate the longest of such arti- 100 cles. It being intended when the machine is employed to vend cigars, for which it is primarily designed, to adapt said machine to vend successfully the largest, the smallest, or any intermediate size or length of cigar ordinarily made and sold it would be natural

to suppose that the width of this slot or the cut-off must be necessarily made adjustable; but practical demonstration proves that the cigars will vary so slightly in diameter that a slot sufficiently wide to receive the largest cigar will successfully receive and manipulate the smallest.

A false, preferably L-shaped, side wall 13 is applied to one wall of the hopper 6, in this instance the said false wall being provided with any suitable well-known means of adjustment. It is preferred to slot the upper horizontal portion of the wall, as indicated at 14, and the same overlying the upper edge of the hopper-wall may be held in any of its laterally-adjusted positions by set-screws 15. The lower edge of the false wall and its front end are so shaped as to escape both the bottom of the hopper and the stationary cut-off 9, and thus, as will be apparent, a manipulation of the adjusting means will result in either an increase or decrease of the width of the hopper as a whole, and consequently the feed-opening. In this manner it will be seen that cigars or other articles to be vended can be readily accommodated as to length.

A suitable display-case 16 may have its front wall hinged, as at 17, to the front wall of the hopper and its rear wall adapted to be secured by a lock, whereby only authorized persons may have access. If the machine is employed for the vending of cigars, for which it is primarily intended, the cigars may be loosely dumped into the hopper and the display-case closed and locked. To better display the cigars, however, it is preferable to remove the bottom of the cigar-box 18, and place said box over the hopper, the contents of the box readily falling into the hopper and fed toward the feed-opening 8 thereof. For the purpose of retaining the box immovably in position, suitable clamps—for example, as 19—may be employed upon the upper edge of the hopper-wall.

Hinged, as at 20, to a cross-bar 21 or other support is a gage-plate 22, the same being located immediately under and in close proximity to the sliding cut-off 11. This gage-plate preferably terminates at the front edge of the opening 8 of the hopper, and therefore immediately in rear of the delivery-opening 12 of the sliding cut-off and above an inclined delivery-chute 23, the delivery end of which communicates with an opening 24 in the side wall of the machine. Through the instrumentality of a screw 25 or any other simple contrivance the said gage-plate can be raised and lowered, whereby the depth of the delivery-opening in the cut-off can be regulated to adapt the machine to handle cigars of various diameters. A spring 26, mounted on a convenient cross-bar, may have its upper free end bearing against the under side of the cut-off for the purpose of giving the same a tendency toward returning to its locked position. It will of course be understood that the cut-off is capable of being operated by any

coin-controlled mechanism; but the one which I will now proceed to describe is the preferred form, for the reason that it may be regulated to vend a plurality of articles with the introduction of but a single coin. I may also provide some retarding device for the cut-off for the purpose of preventing the latter being moved too suddenly to receive and discharge a cigar. One very simple form of such retarding device I have herein illustrated. The same consists of an air-cylinder 27, suitably supported within the casing, and a piston 28, the front end of which is connected by an arm 29 with the sliding cut-off 11. The cylinder, it will be observed, acts as an air-cushion in a manner well understood.

30 designates a coinway mounted on the platform 5 and against the front wall 2 of the casing, by the upper edge of which latter it is surrounded. This coinway is provided along its opposite edges with vertical flanges 31 and may be provided between its ends with an opening 32 of less width than the distance between the said flanges. The coinway extends from one side of the machine to a point near the opposite side, but terminates short of the latter, at which point the platform 5 is provided with a discharge-opening 33, immediately below which and the opening 32 is located a coin-receiving drawer 34, provided with a suitable lock. Mounted upon the sides of the casing, and therefore above and combining with the platform 5 to form an intermediate space, is a protecting-plate 35, the same having at a point above the coinway a circular hole 37, the diameter of which agrees with the width of the coinway. This protecting-plate is further provided with a longitudinally-disposed slot 36 and for the purpose of giving sight to the contents of the coinway may be provided with a glass-covered opening 38.

To the right of the slot 36 of the coinway, which I might also state is continued in the platform 5 and countersunk within said platform, is a disk 39, mounted for free rotation on an axis 40. For a purpose hereinafter apparent the present disk is provided at diametrically opposite sides with two corresponding notches 41, formed in the periphery thereof, and within its edge with a series of six indentations or openings 42, one edge of each of which is beveled. A segmental arm 43 overlies the disk 39 and has its outer end pivoted, as at 44, to the side wall of the casing, its free or opposite end extending to the opposite side of the said disk. On its under side a detent 45 is located, and the same is designed to successively engage with the openings 42 of the disk. A light spring 46, affixed to a convenient point of the casing, has its free end bearing on the rear or curved side of the segmental arm.

A trip-lever 47 is fulcrumed in a plate 48, let into the platform 5, the forward end of said lever passing through a convenient opening formed in one of the flanges 31 of the coin-

way, and therefore terminating slightly beyond said flange in said coinway. If the opening 32 is employed in the way, the trip-lever terminates immediately above the same.

5 The tripping end of this lever is preferably beveled, so that a coin of the proper denomination and which would accurately fit between the flanges 31 may ride over and depress said lever, and smaller denominations of coin will
10 of course drop through the opening 32 and be of no effect so far as operating the machine is concerned. Of course if the machine is intended to operate with a dime there will be no necessity of the opening 32 in the coinway, as the dime represents the smallest coin
15 of our currency. The opposite or rear end of the lever 47 terminates in a depending tooth 49, and said end being the heaviest is normally lowered, so that the aforesaid tooth is
20 in engagement with a notch 50, formed in the upper side of the sliding cut-off 11, whereby until said trip-lever is tripped by a coin the cut-off cannot be moved to the rear to effect a delivery. In rear of its fulcrum-point, but
25 intermediate its ends, the trip-lever is provided with an L-shaped shoulder 51, which when the said lever is in its normal position—that is, with its rear end depressed—engages with either one of the notches 41 of the disk,
30 whereby, as will be obvious, the disk is held against rotation. It will be clear, however, that by depressing the front end of the trip-lever, as by a coin in the coinway, the lever will be elevated at its front end and the L-shaped catch be brought to a position that
35 will permit the disk to rotate.

52 designates a lever mounted to vibrate upon a pin 53. The forward end of the lever may carry a follower-plate or, as shown, be
40 formed with a bifurcation extending under the coinway and at an angle to a longitudinal slot 54, formed in said way. Mounted in the way in the latter instance, which is the one herein shown and preferred, is a loose
45 reciprocating follower-plate 55, the same having a pin 56 depending from its under side through the slot 54 of the coinway and engaging with the bifurcation of the lever 52. Pivotaly connected to the opposite or rear
50 end of the lever 52, as at 57, is a link 58, the opposite end of which is loosely connected to a knob 59, the stem of which depends through the slots 36 in the protecting-plates and platform and is connected with the sliding cut-off 11. In the path of the link 58 lies the
55 front or free end of the segmental arm 43, and at the point where the two come in contact when the link is moved forward the latter is provided with a flanged recess 60, adapted to receive and take over the said free
60 end of the segmental arm. For the support of the free end of the segmental arm above the surface of the disk there may be employed a track 61, the edge of which is formed on
65 the arc of a circle concentric with the pivot of the arm and may be provided with a shoulder 62, and thus form a stop to limit the for-

ward movement of the arm, a pin 63 being formed on the under side of the arm for abutting against the said shoulder.

The operation of the machine may be briefly
70 described as follows: A coin of the proper denomination being placed in the coin-opening 37, the operating-knob 59 is pushed to the rear. The length of the slot 50 permits the
75 knob to have a limited movement notwithstanding the engagement of the same by the rear end of the trip-lever 47. This preliminary movement of the operating-knob moves the coin along the coinway until it has de-
80 pressed the front end of the trip-lever, the rear end of which is thus disengaged from the slot 50 of the sliding cut-off, whereby the latter is released. The manner of advancing the coin along the way will be obvious, in
85 that the link 58, moving in a fixed line at one end, through the guidance of the slots 36 will serve to vibrate the lever 52, thus forcing the follower 55 along the coinway. The cut-off being thus forced to the rear, an article—
90 in this instance a cigar—will fall into the opening 12 thereof, so that a subsequent return movement of the cut-off will cause such article to drop into the inclined discharge-chute 23 and be delivered at the side
95 of the machine through the opening 24 or at any point to which said chute may lead. In this manner it will be obvious that the machine is adapted for single delivery. It will of course be understood that when the ma-
100 chine is thus used—that is, as a single-delivery machine—the segmental arm 43, its spring 46, and the disk 39 are omitted or removed. When, however, these parts thus enumerated are in position, it will be seen that the rear-
105 ward movement of the link 58 will cause the same to contact with the free end of the segmental arm 43, so that the latter is carried to the rear. Rotation of the disk is permitted, it will be understood, by the elevating of the rear
110 end of the trip-lever 47, the catch 51 thereof being raised so as to disengage from the peripheral opening or notch 41. The movement of the link 58 is sufficient to cause the segmental lever, through its catch 45, to advance or rotate
115 the disk the distance of one hole 42. As the knob is returned and the cigar or other article delivered the segmental lever through its spring 46 is likewise returned to the position shown in Fig. 3, where its catch 45 is en-
120 gaged with the next succeeding opening 42. The peripheral notch 41 having passed beyond the catch 51 of the trip-lever the latter will not reengage this time with the former, and therefore the catch at the rear end of the
125 lever cannot engage with the sliding cut-off; but the trip-lever will be supported by the disk in an elevated position. The knob can now be moved to the rear, a second article, such as a cigar, caught by the sliding cut-off
130 and delivered, the disk being again rotated the distance between its openings 42. Still the parts will remain in the unlocked position, and a third movement of the knob and

a third delivery may take place. Upon the return of the knob to its initial position for the third time (by which time three articles will have been delivered for the single coin inserted) the opposite peripheral notch 41 will have arrived opposite or in line with the catch 51 of the trip-lever, whereupon the lever will drop at its rear end, thereby throwing the catch 49 into engagement with the slot or recess 50 of the cut-off and the catch 51 into engagement with the notch 41 of the disk. In this manner after the delivery of the three articles for the one coin the parts immediately become locked and can only be unlocked and the machine again operated successively for the delivery of three additional articles by the insertion of another coin. In this manner it will be observed that, for instance, three cigars for a quarter, three for a half, or three for a dollar may be vended, as well as three for a dime or a nickel. It will be obvious that this system may be carried out so as to deliver any given number of articles for a single coin. For instance, as I have illustrated in Fig. 7, by employing but one peripheral notch and the six openings 42 the machine may be operated six times before locking. It will also be obvious that the single notch 41 may be used in connection with a disk only having three openings, and thus only three deliveries made before the parts again become locked, or, again, by employing only two openings 42 but two deliveries may take place, and so on, all of which is within the scope of my invention.

What I claim is—

1. In a vending-machine, the combination with a delivery mechanism, of means for operating said delivery mechanism, a coin-advancing mechanism operated by said delivery-operating means, and means operated by said coin-advancing mechanism to allow a plurality of operations of the delivery mechanism upon the insertion of each single coin, whereby a plurality of articles may be vended.

2. In a vending-machine, the combination with a delivery mechanism, of means for operating said delivery mechanism, a coin-advancing mechanism operated by said delivery-operating means, and means operated by said coin-advancing mechanism to allow a plurality of successive operations of the delivery mechanism whereby a plurality of successive deliveries upon the insertion of each single coin will occur.

3. In a vending-machine, the combination with a delivery mechanism, of means for operating said delivery mechanism, a coin-advancing mechanism operated by said delivery-operating means, and a removable mechanism operated by said coin-advancing mechanism to allow said delivery mechanism to operate a plurality of times upon the insertion of each single coin, whereby a plurality of articles will be vended.

4. In a vending-machine, the combination with a delivery mechanism comprising a slid-

ing cut-off, of means for operating the sliding cut-off, a coin-advancing mechanism operated by said cut-off-operating means, and means operated by said coin-advancing mechanism to allow a plurality of successive operations of said cut-off upon the insertion of a single coin, whereby a plurality of articles will be vended.

5. In a vending-machine, the combination with a delivery mechanism, and a trip-lever for locking said delivery mechanism and adapted to be unlocked upon the insertion of a coin, of means for retaining the trip-lever in an unlocked position upon the insertion of a coin and during a given number of successive operations of the said delivery mechanism, whereby a plurality of vendable articles may be successively delivered.

6. In a vending-machine, the combination with a cut-off and a trip-lever for locking said cut-off and adapted to be unlocked upon the insertion of a coin, of means for retaining the trip-lever in an unlocked position upon the insertion of a coin and during a given number of successive operations of said cut-off, whereby a plurality of vendable articles may be successively delivered.

7. In a vending-machine, the combination with a delivery mechanism, a trip-lever for engaging and locking the same and adapted to be disengaged therefrom by a coin and a coin-advancing mechanism, of a rotatable disk adapted to engage and retain said trip-lever in either its engaged or disengaged positions and lock said coin-advancing mechanism, and means for rotating said disk so as to cause the same to engage said trip-lever.

8. In a vending-machine, the combination with a delivery mechanism, a trip-lever for engaging and holding the same and for disengaging from the same, a coinway adapted to guide a coin to unlock or disengage the trip-lever, and a coin-advancing mechanism, of a rotatable disk notched to engage the trip-lever when in its locked position with relation to the delivery mechanism, and means operated by the coin-advancing mechanism for rotating the disk a predetermined distance at each successive reciprocation of the coin-advancing mechanism.

9. In a vending-machine, the combination with a delivery mechanism comprising a sliding cut-off, a trip-lever engaging the same and provided with an L-shaped catch, a coinway adapted to guide the coin to depress the lever, and a coin-advancing mechanism, of a rotatable disk provided with a peripheral notch adapted to receive said L-shaped catch when the trip-lever is in its engaged position, and means for advancing or rotating the disk a predetermined distance upon each disengagement of the trip-lever and movement of the delivery mechanism.

10. In a vending-machine, the combination with a delivery mechanism comprising a sliding cut-off, a trip-lever engaging the same and provided with an L-shaped catch, a coin-

way adapted to guide a coin to depress the lever, and a coin-advancing mechanism, of a rotatable disk provided with a peripheral notch adapted to receive said L-shaped catch when the trip-lever is in its engaged position and when moved to support said lever, and means operated by the coin-advancing mechanism for advancing said disk at each movement thereof.

10 11. In a vending-machine, the combination with a delivery mechanism comprising a sliding cut-off, of a trip-lever engaging the same and adapted to be thrown out of engagement therewith upon the insertion of a coin, a disk mounted for rotation adjacent to the trip-lever and provided with depressions and adapted to engage at certain points with said trip-lever, an arm pivoted over the disk and adapted to engage the depressions, a spring for throwing the arm in one direction, and a coin-advancing device connected with the cut-off and adapted to come in contact with and operate the said arm.

25 12. In a vending-machine, the combination with a delivery mechanism comprising a sliding cut-off, a trip mechanism engaging the cut-off and adapted to be operated upon the advancement of a coin, a coin-advancing mechanism, a rotatable disk adapted to engage the trip mechanism at predetermined points, and means for advancing or partially rotating the disk upon each movement of the coin-advancing mechanism and the cut-off.

35 13. In a vending-machine, the combination with a delivery mechanism comprising a slid-

ing cut-off, of a trip mechanism engaging the cut-off and adapted to be operated by a coin, a coin-advancing mechanism connected with the trip mechanism, a disk mounted for rotation at one side of the trip mechanism, a yielding vibratory arm adapted to engage with and advance or partially rotate said disk, said arm being adapted to be operated by said coin-advancing mechanism.

45 14. In a vending-machine, the combination with a delivery mechanism comprising a sliding cut-off, a trip-lever at its rear end engaging said cut-off and between its ends provided with a lug at its front end adapted to be depressed by a coin, a coin-advancing mechanism connected with the cut-off a disk mounted for rotation above the trip-lever and having peripheral notches at predetermined points for engaging the same, and between said notches adapted to support said lever in an elevated position, a vibratory arm pivoted at one side of and extending over the disk and provided with a detent adapted to engage openings in the disk, and a spring for throwing said arm in one direction, said arm being adapted to be operated in the opposite direction by the movement of the coin-advancing mechanism.

In testimony whereof I affix my signature in presence of two witnesses.

DALLAS KNOWLTON.

Witnesses:

H. O. FRENCH,
W. S. DUVAL.