

(No Model.)

3 Sheets—Sheet 1.

C. H. DRIVER.
SANDPAPERING MACHINE.

No. 598,671.

Patented Feb. 8, 1898.

Fig. 1.

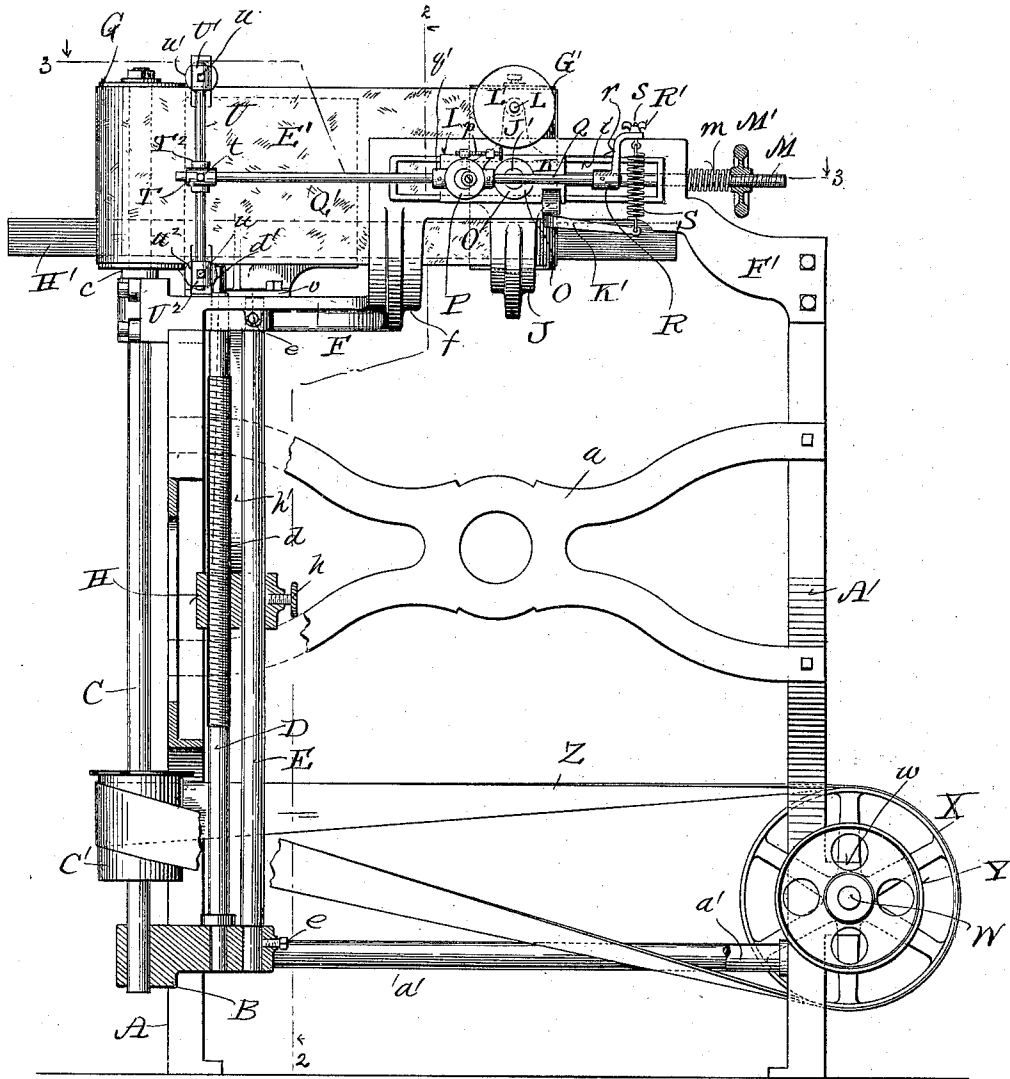

Witnesses:
Geo. W. Young,
B. C. Roloff

Inventor
Charles H. Driver
By H. G. Underwood,
Attorney

(No Model.)

3 Sheets—Sheet 2.

C. H. DRIVER.
SANDPAPERING MACHINE.

No. 598,671.

Patented Feb. 8, 1898.

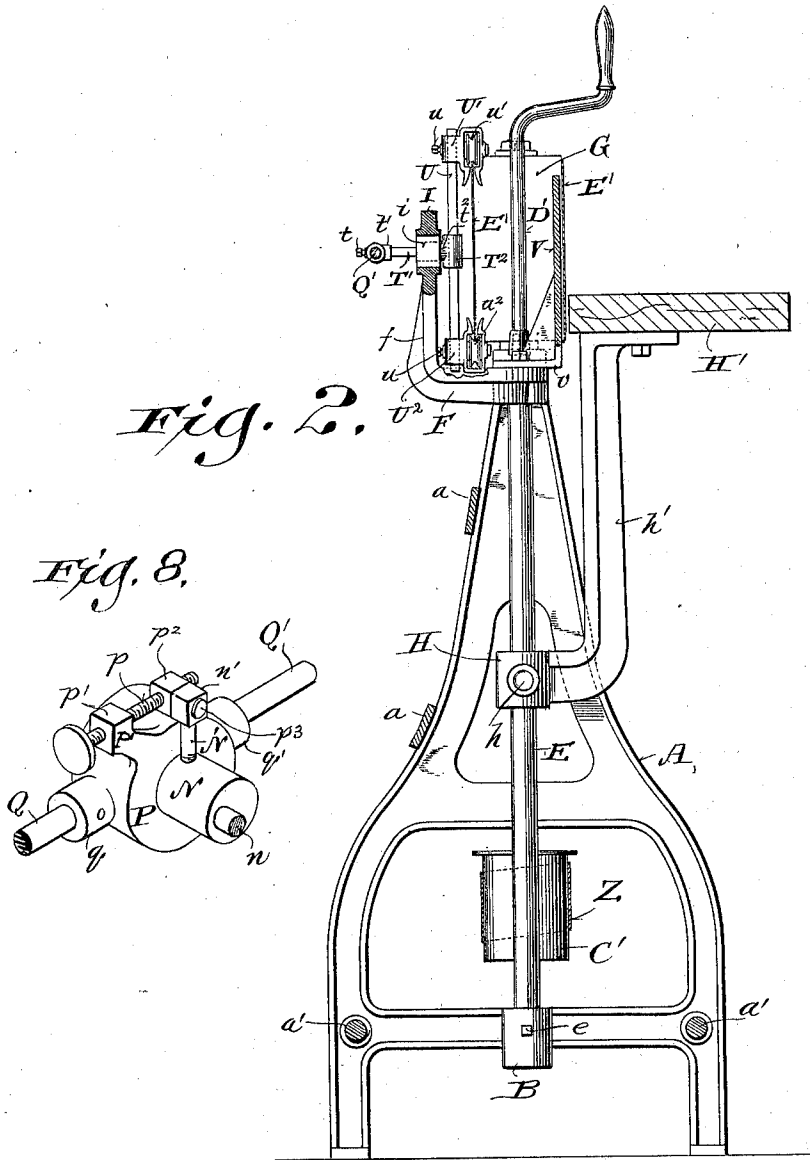

Witnesses:
 Geo. W. Young,
 B. C. Roloff

Inventor
 Charles H. Driver,

By H. G. Underwood
 Attorney

(No Model.)

3 Sheets—Sheet 3.

C. H. DRIVER. SANDPAPERING MACHINE.

No. 598,671.

Patented Feb. 8, 1898.

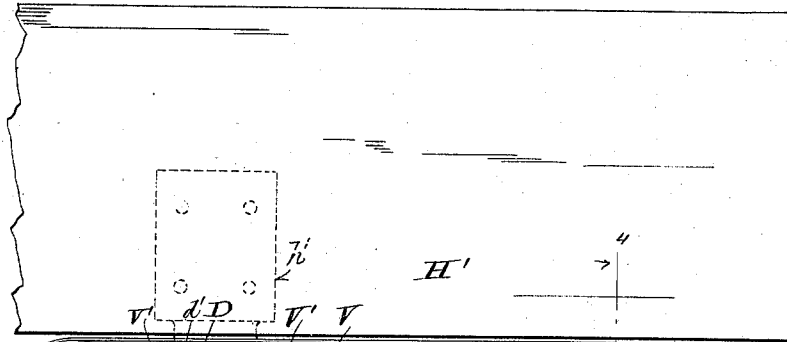

Fig. 3.

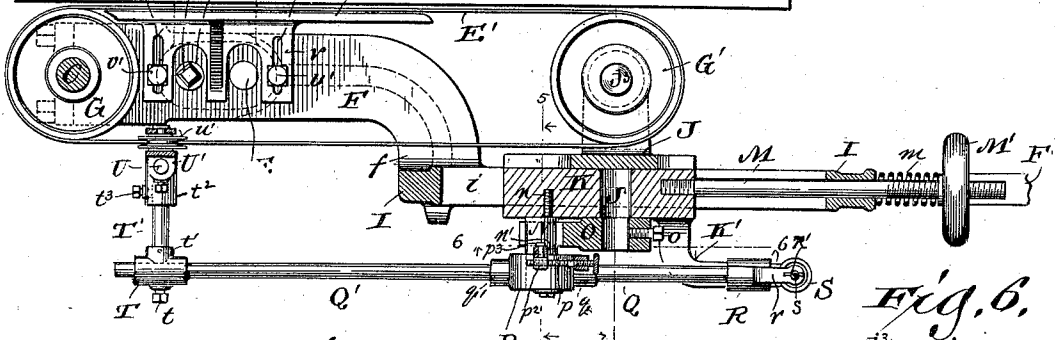

Fig. 4.

Fig. 5.

Fig. 6.

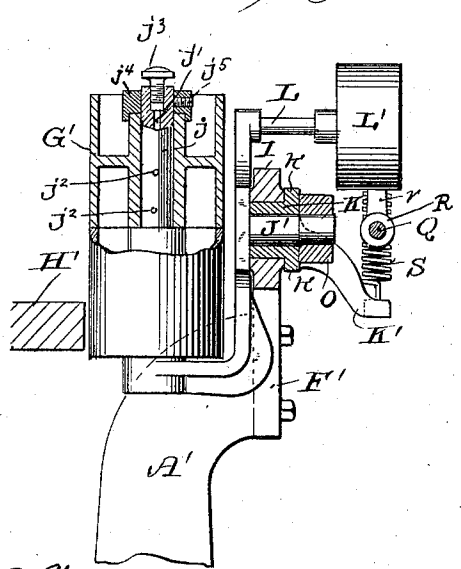

Fig. 7.

Witnesses:
 Geo. W. Young
 B. C. Roloff

Inventor
 Charles H. Driver,
 By H. G. Underwood
 Attorneys

UNITED STATES PATENT OFFICE.

CHARLES H. DRIVER, OF RACINE, WISCONSIN.

SANDPAPERING-MACHINE.

SPECIFICATION forming part of Letters Patent No. 598,671, dated February 8, 1898.

Application filed April 29, 1897. Serial No. 634,340. (No model.)

To all whom it may concern:

Be it known that I, CHARLES H. DRIVER, a citizen of the United States, and a resident of Racine, in the county of Racine and State of Wisconsin, have invented certain new and useful Improvements in Sandpapering-Machines; and I do hereby declare that the following is a full, clear, and exact description thereof.

My invention relates to that class of sandpapering-machines which employ an endless sandpapering-belt revolving around rollers or drums, and has special reference to means for keeping the sandpapering-belt in a true position or for restoring it to such position automatically whenever it starts to run off the drums; and to that end it consists of certain peculiarities of construction and combination of parts, as will be fully set forth hereinafter and subsequently claimed.

In the drawings, Figure 1 is a side elevation of my said machine, partially broken away or in section to better illustrate certain details of construction. Fig. 2 is a transverse vertical section on the line 2 2 of Fig. 1. Fig. 3 is a horizontal section on the line 3 3 of Fig. 1 and drawn to an enlarged scale. Figs. 4, 5, and 6 are detail sectional views on the lines 4 4, 5 5, and 6 6, respectively, of Fig. 3. Fig. 7 is a detail sectional view on the line 7 7 of Fig. 5, and Fig. 8 is a detail perspective view.

Referring to the drawings, A A' represent the side pieces or standards, and a a' the cross-pieces, of the frame of my machine.

B is a bearing block or box at the lower end of one of the standards for receiving the lower ends of the vertical shafts C D and rod E, whose upper ends are journaled or supported in one end F of a casting F F', which forms the top of the frame. The shaft C has a shoulder c just above the upper surface of the box formed on the end of the casting F, above which shoulder the said shaft carries a vertical drum G, properly secured to the shaft, and there is another drum C' fast on the lower part of this shaft. The shaft D is provided with exterior screw-threads, as shown at d, and its upper projecting end d' is squared to receive an operating-crank D',

the latter being shown in Fig. 2. The rod E is held stationary on its bearings by set-screws e e.

H is a nut-block on the screw-shaft D, having besides its screw-threaded bore which receives said shaft a smooth vertical bore through which the rod E passes, and h is a set-screw passing through said nut-block H and bearing against said rod E. Rising from this nut-block H is an arm h', on the upper flanged end of which the work-table H' rests and to which it is bolted.

The ends F F' of the top casting are united by a raised central portion I, having a longitudinal slot therein, which receives a slide-block K. The raised part I of the casting is connected to the inner part of the end F by a curved transverse arm f, so that the part I and end F' of the casting are considerably farther away from the line of the work-table H' than the end F of said casting.

J is a hanger having a stud J' projecting therefrom and extending through an opening in the slide-block K, whereby said hanger is swiveled to said block, and this hanger supports a vertical drum G' in the space between the part I of the top casting and the work-table H' and in line with the heretofore-named vertical drum G, these two drums being connected by an endless sandpapering-belt E', formed, preferably, of a strip of paper covered with sand or emery. The drum G' revolves on a vertical spindle j, which projects upward from the lower horizontal part of the hanger J. This spindle j has a vertical oil-channel j' therethrough, with openings j² j², so as to lubricate the hub of the drum, which drum is made in two parts, as shown in Fig. 4, and the oil-channel is closed at top by a screw j³ to keep it free from the sandpaper-dust, and there is a cap j⁴ fitting around the spindle j and bearing on the top of the hub of the upper part of the drum G' for a like purpose, the cap being held in place by a set-screw j⁵, all as shown in Fig. 4.

The central part of the hanger J is longitudinally extended on each side, as shown in Fig. 3, and from the upper part of this hanger there projects outwardly a rod L, carrying at its outer end a counterweight L' to counter-

balance the drum G'. The outer end of the block K has a screw-threaded bore therein to receive the inner screw-threaded end of a rod M, which passes through a smooth-bored opening in the outer end wall of the part I of the casting, and the outer end of this rod M is also screw-threaded to receive a hand-wheel M', and between said hand-wheel and the outer end wall of the casting I there is interposed a spiral spring *m*, encircling said rod.

From the lower outer end of the block K there projects a curved arm K', said arm projecting first transversely and downwardly and thence longitudinally with said block, and the said block has upper and lower longitudinal outer flanges *k k*, extending above and below the line of the slot *i*, within which the body of said block moves. The outer end of the stud J', which passes through the block K, is preferably somewhat reduced in diameter beyond the line of said block, and this reduced end passes through the hub of a forked lever O, held to said stud by a set-screw *o*, and the forks of this lever embrace an eccentric stud N, movably secured to the slide-block K, as by screw *n*. P is a collar on this eccentric stud N, having socketed couplings *q q'* integral therewith and projecting from the opposite sides thereof.

P' is an arm projecting angularly from the collar P and terminating in a block *p'*, said block being provided with a screw-threaded bore for the passage of a regulating-screw *p* therethrough.

N' is a pin screwed into the stud N and rising therefrom and terminating in a block *n'*. The screw *p* also passes through a screw-threaded bore in another block *p''*, and a headed bolt *p'''* passes through a smooth bore in the block *n'* and screws into the block *p''*, whereby the said block *p''* is swiveled to the block *n'*, or, if preferred, the bolt *p'''* may be rigid with the block *p''*, and after passing through the smooth bore in block *n'* the end may be upset or headed or a nut or head screwed thereon. By this construction the correct relative positions of the eccentric stud N and collar P can be secured by manipulating the regulating-screw *p*.

From the socketed coupling *q* there extends a rod Q, and on the outer end of this rod there is a head R, having an upward-extending curved arm *r*, through which extends a screw-eye *s*, to the eye in the under side of which there is connected one end of a spiral spring S, whose other end is connected to the end of the arm K', which projects from the slide-block K, and the tension of this spring is regulated by a thumb-nut R' on top of the arm *r* in engagement with the screw-eye *s*.

Q' is a rod extending from the socketed coupling *q'* and at its other end passing through a tubular coupling T, to which it is secured by set-screw *t*, this coupling having also a socketed coupling *t'*, to which is secured

one end of a transverse rod T', whose other end is received within a socketed coupling *t''*, projecting from a vertical tubular coupling T² and held therein by set-screw *t'''*.

U is a vertical rod passing through the coupling T² and having secured to its upper and lower ends the sheave-blocks U' U² by means of set-screws *u u*, said sheave-blocks carrying vertically-disposed grooved pulleys *u' u''*, whose grooves take in the upper and lower edges, respectively, of the sandpapering-belt E', as best shown in Fig. 2.

V is a vertical presser-plate rising from a horizontal base portion *v*, which latter rests upon the end F of the top casting and is adjustably secured thereto, so as to be moved nearer to or farther from the belt E', by means of slots V' in the horizontal base part *v* of said plate and bolts *v'*, passing through said slots and through said casting F, as best shown in Fig. 3.

The standard A' of the frame has a box or bearing *w*, in which is journaled a transverse shaft W, on one end of which is a belt-pulley X and on the other end of which is the power-pulley Y, which receives the belt (not shown) from the source of power. There is, of course, a fast and a loose pulley at this point Y, one being concealed by the other in Fig. 1, and from the pulley X a belt Z runs to the drum C' on vertical shaft C, as best shown in Fig. 1.

The operation of my device is as follows: Power being communicated to the power-pulley Y, this revolves shaft W and pulley X, and the latter through belt Z and drum C' revolves shaft C, thereby revolving the vertical drum G on the upper end of said shaft C, sandpapering-belt E', and drum G'. The article to be sandpapered rests on the work-table H' and is held against the belt E', pressing the latter against the vertical plate V, which latter is needed to take the strain off the said belt. The tendency of a vertically-arranged sandpapering-belt is to run up or down on its carrying-drums, and the chief object of my present invention is to counteract this and keep the said belt in a true position, so that it will revolve in a horizontal line. For example, let it be understood that the belt E' begins to rise. As it does this it will carry rod U up with it, (by reason of the engagement of the pulleys *u' u''* with the upper and lower edges of the belt,) and this will raise the outer end of rod Q' and turn the collar P, coupled to the inner end of rod Q', and this movement of rod Q' and collar P will turn the eccentric stud N, so as to raise the forked end of lever O, and this, acting through stud J', to which said lever is made fast, will tilt the hanger J and carry the inner drum G' to an angle, with the lower part of said drum projected toward the drum G, and hence loose and away from the sandpapering-belt E', and with the upper part of said inner drum G' tight against the upper part of the belt E', and the belt as it continues to revolve around

its drums will work down automatically, and as it does so all the parts will resume their normal positions (illustrated in the drawings) and the belt will run true. Similarly if the belt starts to run downward this will carry the rod U and outer end of rod Q' downward and turn the eccentric stud in the opposite direction, carrying the forked end of the lever O down and thereby tilting the hanger J, and with it the drum G', in the opposite direction to that first described, so that the belt E' will be tightened at the bottom and the drum G', loose and away from the belt at the top, and as this happens the belt E', continuously revolving around its drums, will at once begin to work upward until the normal condition is restored.

By means of the slotted portion I of the top casting and the described slide-block K and hanger J, I am enabled to use my device with sandpapering-belts of different lengths, the rod M, with the wheel M', serving as an adjusting device and belt-tightener, and at the same time, as these belts are fragile, the spring m on the rod M permits a slight yield and prevents injury to the belt from any sudden or unexpected strain.

My device may be readily adjusted to belts of different widths also by loosening the set-screws *uu* and moving the sheave-blocks U' U² on the rod U until the grooved pulleys *u' u²* just receive the edges of the belt E' and then tightening the set-screws. Further, if with a small belt it is desired to use smaller drums G G' both the rod T' and presser-plate V are adjustable, as described, and the height of the work-table H' is regulated by a simple revolution of the screw-shaft D in either direction by the crank D', which raises or lowers the nut-block H, and with it the arm *h'* and work-table, the rod E serving to insure the vertical movement of said nut-block and prevent cramping. The weight of the rods Q' and U and their attachments is counter-balanced by the action of the spring S, connecting the shorter rod Q to the arm K', which overcomes any tendency of the rod Q' to drop at its outer end and keeps said rod always in a horizontal position, the tension of the spring S being regulated by the thumb-nut R', as described.

Having thus described my invention, what I claim as new, and desire to secure by Letters Patent, is—

1. In a sandpapering-machine, the combination of a drum revolving on a fixed axis, another drum revolving on an obliquely-movable axis, an endless sandpapering-belt on said drums, and means for automatically changing the axis of the second drum from a line parallel with that of the first drum to a line oblique thereto whenever the belt begins to move off said drums.

2. In a sandpapering-machine, the combination of a revolving shaft, a drum rigid on said shaft, another drum supported on a tilting hanger, a lever rigidly connected to said

hanger, an endless sandpapering-belt on said drums, grooved pulleys engaging the opposite edges of said belt, and a connecting device between said pulleys and said lever for tilting the hanger, and tightening one end of the drum carried thereby against the belt, whenever said belt begins to move off said drums.

3. In a sandpapering-machine, the combination of a revolving shaft, a drum rigid on said shaft, a tilting hanger, a stud rigid therewith journaled in said machine, a second drum supported on said hanger, an endless sandpapering-belt on said drums, a lever rigidly secured to said stud, an eccentric stud movably secured to the machine and in engagement with said lever, a movable collar on said stud, a link connection between said collar and stud, a rod coupled to said collar, a transverse rod rigidly connected to the outer end of the last-named rod, and grooved rollers connected to the opposite ends of the transverse rod and in engagement with the opposite edges of the endless sandpapering-belt.

4. In a sandpapering-machine, the combination of a revolving shaft, a drum rigid on said shaft, a tilting hanger having a stud rigid therewith pivotally attached to said machine, a second drum supported on said hanger, an endless sandpapering-belt on said drums, a lever rigidly secured to the hanger-stud and having a forked free end, an eccentric stud movably secured to the machine and in engagement with the forked end of said lever, a movable collar on said stud, an arm projecting from said collar and terminating in a block, a pin rising from said eccentric stud and terminating in a block, another block swiveled to the last-named block, a regulating-screw extending through the block on the collar-arm and through the said swiveled block, a rod coupled to said collar, a transverse rod rigidly connected to the outer end of the last-named rod, and grooved rollers connected to the opposite sides of the transverse rod and in engagement with the opposite edges of the endless sandpapering-belt.

5. In a sandpapering-machine, the combination of a revolving shaft, a drum rigid on said shaft, a slotted supporting-frame, a slide-block movable in the slot in said frame, an arm projecting from said slide-block, a tilting hanger having a stud rigid therewith journaled in said slide-block, a spindle on said hanger, a second drum on said spindle, an endless sandpapering-belt on said drums, a lever rigidly secured to the hanger-stud and having a forked free end, an eccentric stud movably secured to the slide-block and in engagement with the forked end of the lever, a movable collar on said stud, a link connection between said collar and stud, two rods of unequal length coupled to said collar and extending in opposite directions, a spiral spring connecting the outer end of the shorter rod with the arm on the slide-block, a transverse rod rigidly connected to the outer end of the longer rod, and grooved rollers con-

ned to the opposite ends of the transverse rod and in engagement with the opposite edges of the endless sandpapering-belt.

5 6. In a sandpapering-machine, the combination with a slotted supporting-frame, of a revolving shaft, a drum rigid on said shaft, a slide-block movable in the slot in said frame, a hanger pivoted in said slide-block, a second drum carried by said hanger, an endless sand-
10 papering-belt on said drums, a screw-rod secured to said slide-block and projecting through the end of the slotted frame, a movable hand-wheel on the projecting end of said
15 screw-rod, and a spring on said rod interposed between said hand-wheel and the outer end of said slotted frame.

7. In a sandpapering-machine, the combination with a supporting-frame, of a revolving vertical shaft, a drum rigid on the upper
20 end of said shaft, another drum vertically

suspended from a hanger on said frame, a vertically-disposed endless sandpapering-belt on said drums, a vertically-arranged screw-shaft and a vertical guide-rod, a nut-
25 block vertically movable on the said screw-shaft and guide-rod, an arm projecting up from said nut-block, a work-table secured to said arm just outside the line of travel of said sandpapering-belt, and a vertical presser-
30 plate adjustably secured to said frame inside of said sandpapering-belt, and in line with said work-table.

In testimony that I claim the foregoing I have hereunto set my hand, at Milwaukee, in the county of Milwaukee and State of Wis-
35 consin, in the presence of two witnesses.

CHARLES H. DRIVER.

Witnesses:

H. G. UNDERWOOD,
B. C. ROLOFF.