



(51) International Patent Classification:

B28B 1/00 (2006.01) B28C 5/08 (2006.01)
B28C 7/02 (2006.01)

(21) International Application Number:

PCT/EP2024/067273

(22) International Filing Date:

20 June 2024 (20.06.2024)

(25) Filing Language:

English

(26) Publication Language:

English

(30) Priority Data:

23382655.1 27 June 2023 (27.06.2023) EP
23193159.3 24 August 2023 (24.08.2023) EP

(71) Applicants: UNIVERSITAT POLITÈCNICA DE
CATALUNYA [ES/ES]; C/ Jordi Girona, 31, 08034

Barcelona (ES). FUNDACIÓ CENTRE CIM [ES/ES]; C/
Llorens i Artigas, 12, 08028 Barcelona (ES).

(72) Inventors: FENOLLOSA ARTÉS, Felip; C/ Roger de
Flor 73, 6è 1a, 08013 Barcelona (ES). POUDELET, Loui-
son; C/ Carretes, 57 1r 1a, 08001 Barcelona (ES). CALVO
DUARTE, Laura; C/ Molist, 3, Baixos 2, 08024 Barcelona
(ES). UCEDA MOLERA, Roger; C/ Roureda, 36, 08849
Sant Climent de Llobregat (ES).

(74) Agent: TORNER, JUNCOSA I ASSOCIATS, SL; C/ Pau
Clarís, 108, 1r 1a, 08009 Barcelona (ES).

(81) Designated States (unless otherwise indicated, for every
kind of national protection available): AE, AG, AL, AM,
AO, AT, AU, AZ, BA, BB, BG, BH, BN, BR, BW, BY, BZ,
CA, CH, CL, CN, CO, CR, CU, CV, CZ, DE, DJ, DK, DM,
DO, DZ, EC, EE, EG, ES, FI, GB, GD, GE, GH, GM, GT,
HN, HR, HU, ID, IL, IN, IQ, IR, IS, IT, JM, JO, JP, KE, KG,

(54) Title: SYSTEM AND METHOD FOR EXTRUDING CEMENTITIOUS MATERIAL AND SYSTEM FOR ADDITIVE MANUFACTURING OF A CEMENTITIOUS MATERIAL BASED STRUCTURE

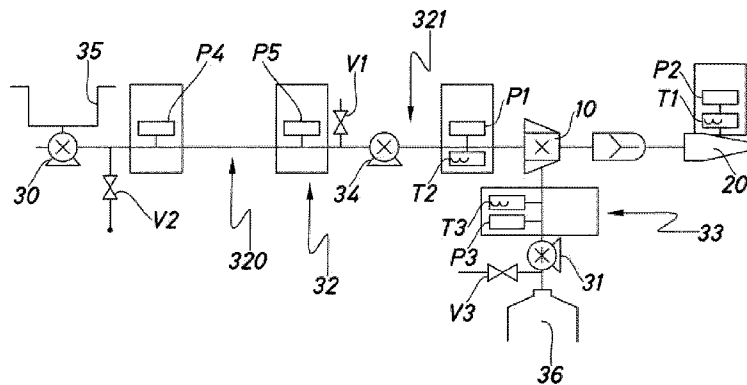

Fig.4

(57) Abstract: It is disclosed a system for extruding cementitious material comprising: - at least one pump (30, 34) of cementitious material; - at least one pump (31) of additive for cementitious material; - a mixing chamber (10) comprising a cementitious material inlet (11) and an inlet (12) of additive for cementitious material; and being configured to mix the cementitious material with the additive for cementitious material forming a printing composition; - an extruder (20) for extruding at least one layer of the printing composition; - a control unit; wherein the extruder (20) comprises at least one temperature sensor (T1), and the mixing chamber (10) comprises at least one pressure sensor (P1) at the cementitious material inlet (11), each sensor being operatively connected to the control unit, which is configured to adjust the amount of additive for cementitious material in the printing composition. It is also disclosed a method for



KH, KN, KP, KR, KW, KZ, LA, LC, LK, LR, LS, LU, LY,
MA, MD, MG, MK, MN, MU, MW, MX, MY, MZ, NA,
NG, NI, NO, NZ, OM, PA, PE, PG, PH, PL, PT, QA, RO,
RS, RU, RW, SA, SC, SD, SE, SG, SK, SL, ST, SV, SY, TH,
TJ, TM, TN, TR, TT, TZ, UA, UG, US, UZ, VC, VN, WS,
ZA, ZM, ZW.

(84) Designated States (*unless otherwise indicated, for every kind of regional protection available*): ARIPO (BW, CV, GH, GM, KE, LR, LS, MW, MZ, NA, RW, SC, SD, SL, ST, SZ, TZ, UG, ZM, ZW), Eurasian (AM, AZ, BY, KG, KZ, RU, TJ, TM), European (AL, AT, BE, BG, CH, CY, CZ, DE, DK, EE, ES, FI, FR, GB, GR, HR, HU, IE, IS, IT, LT, LU, LV, MC, ME, MK, MT, NL, NO, PL, PT, RO, RS, SE, SI, SK, SM, TR), OAPI (BF, BJ, CF, CG, CI, CM, GA, GN, GQ, GW, KM, ML, MR, NE, SN, TD, TG).

Published:

— *with international search report (Art. 21(3))*

extruding cementitious material and a system for additive manufacturing of a cementitious material-based structure.

DESCRIPTION

SYSTEM AND METHOD FOR EXTRUDING CEMENTITIOUS MATERIAL AND SYSTEM
FOR ADDITIVE MANUFACTURING OF A CEMENTITIOUS MATERIAL BASED
STRUCTURE

5

Technical field

The present invention is directed to a system and a method for extruding cementitious material. The present invention also discloses a system for additive manufacturing of a cementitious material based structure.

10 Background of the Invention

EP 3260258 A1 discloses a method of placing a flowable construction material comprising a hydraulic binder for building structural components layer by layer.

WO 2018/229419 A1 discloses a system for extruding cementitious material beads for a robot used for the additive manufacturing of architectural structures, the system comprising a safety pressure sensor of said cementitious material upstream of a mixing enclosure, said safety pressure sensor being configured to measure the pressure upstream of said mixing enclosure so as to be able to prevent the risk of clogging of the mixing enclosure or of an outlet nozzle.

WO 2018/115166 A1 relates to a method for producing a shaped body from a curable material, in particular from a mineral binder composition, wherein the curable material is applied layer by layer in an additive method, in particular in an additive free-space method, by means of a printing head that can be moved in at least one spatial direction and wherein an application rate of the curable material and the temporal development of strength of the curable material are coordinated with each other.

EP 3708320 A1 discloses a system for applying a building material including: a mixing device for mixing individual components of the building material into a curable building material; a pressure head which can be moved in at least one spatial direction and by means of which the workable building material can be applied; a delivery line, with which the curable building material can be conveyed from the mixing device to the pressure head; at least one delivery device for delivering the curable building material from the mixing device through the delivery line to the pressure head; a feed device, which is designed in such a manner that at least two separate components of the building material can be fed via at least two separate inlets into the mixing device, more particularly into a mixing chamber of the mixing device.

CN 116122584 A discloses a feeding device for concrete printing comprising a feeding port, a liquid material bin, a stirrer, a plunger pump, a control module and a box shell used for fixing and supporting. The stirrer comprises a motor and a stirring box, the motor is connected with the stirring box by a rotating shaft, the feeding port and the liquid material bin are both
5 connected with the stirring box, the plunger pump comprises a hydraulic box and a plunger cavity, the hydraulic box is connected with the plunger cavity, the stirring box is connected with the plunger cavity by a pipeline, and an outlet of the plunger cavity is connected with a discharging pipeline. A first temperature sensor and a viscosity sensor are fixed in the stirring
10 box, the first temperature sensor and the viscosity sensor are both connected to a control module, a second temperature sensor and a pressure sensor are arranged at the joint of the plunger cavity and the discharging pipeline, and the second temperature sensor and the pressure sensor are connected to the control module.

FR 3125458 A1 discloses a three-dimensional printing head comprising a dynamic mixer including a mixer housing, which defines a mixing chamber, a supply inlet configured to supply
15 the mixing chamber with a mineral composition and a discharge outlet; and an injector for injecting a building material additive into the mixing chamber. The injector comprises a tubular injection member which is flexible and has an injection outlet, the tubular injection member being elastically deformable between a first state in which the tubular injection member is configured to allow flow of building material additive through the tubular injection member and
20 towards the injection outlet, and a second state in which the tubular injection member is configured to prevent flow of the mineral composition from the mixing chamber and through the tubular injection member.

FR 3088569 A1 discloses a system for extruding strands of building material system for a robot for additive manufacturing of architectural structures comprising: an extrusion head for strands
25 of building material moved along a predetermined trajectory; a circuit for supplying building material to said extrusion head; and a device for fluidizing extruded strands adapted to fluidize a previously extruded lower strand, prior to extrusion of said upper strand onto this lower strand, so as to maximize adhesion between an upper strand being extruded and a lower strand previously extruded and fluidized by this fluidizing device.

30 Description of the Invention

The present invention concerns to a system and to a method for extruding cementitious material, as defined in the appending claims.

The proposed system comprises, in a manner already known, the following:

- at least one pump of cementitious material;
- at least one pump of additive for cementitious material;
- a mixing chamber comprising a cementitious material inlet connected to the at least one pump of cementitious material via a cementitious material supply line, and an inlet of additive for cementitious material connected to said least one pump of additive for cementitious material via a supply line of additive for cementitious material; said mixing chamber being configured to mix the cementitious material with the additive for cementitious material, thereby forming a printing composition;
- an extruder for extruding at least one layer of the printing composition through an outlet thereof;
- a control unit for controlling the aforementioned elements of the system.

A cementitious material refers to a substance or mixture that has the ability to set and harden through a chemical reaction resulting in a solid, durable product. The cementitious material primarily consists of cement, which is a fine powder made from a combination of minerals, typically including calcium silicates, aluminates, and ferrites and may include other aggregates such as sand and gravel, in combination with water, forming concrete or mortar. The addition of water to the mix triggers the chemical reaction known as hydration leading to the hardening of the cementitious material. Cementitious materials exhibit several desirable characteristics, including good compressive strength, durability once hardened, and the ability to adhere well to other materials, especially porous materials.

A pump of cementitious material is a device adapted for pumping the cementitious material, which is a dense material, with a viscosity much higher than that of water, through a supply line to the cementitious material inlet. The pump provides the necessary pressure and flow rate to move the cementitious material from its source to the mixing chamber.

The additive for a cementitious material refers to a substance or chemical compound that, incorporated into the cementitious mixture, enhances or modifies its properties. These additives are typically introduced in small quantities and serve specific functions during the cementitious material's production, application, or performance.

Additives for cementitious materials can have various purposes and may include, for example, water reducers, also known as plasticizers or superplasticizers, used to reduce the amount of water needed in the cementitious mixture while maintaining workability improving the flowability and rheological properties of the mixture, set modifiers, such as accelerators that
5 influence the setting time of the cementitious material shortening the setting time, air-entraining agents which stabilize microscopic air bubbles within the cementitious material enhancing the workability, freeze-thaw resistance, and durability of the material, and many others.

The pump of additive for cementitious material functions similarly to the pump of cementitious material but is specifically designed for pumping the additives that enhance or modify the
10 properties of the cementitious material.

The mixing chamber is a chamber or vessel where the cementitious material feed from the pump of cementitious material is mixed with the additive for cementitious materials feed from the pump of additive for cementitious material. The cementitious material enters the chamber through a supply line, while the additive enters through a separate supply line. The mixing
15 chamber is designed to thoroughly mix the two components, resulting in a homogenous printing composition. It can be achieved, for example, by including static or movable blades or deflectors within the mixing chamber designed to produce turbulences in the flow of materials passing through the mixing chamber.

The extruder is responsible for extruding or depositing the printing composition onto a desired
20 surface, typically in layers. It takes the homogenously mixed printing composition from the mixing chamber and pushes it through an outlet. The extruder can be equipped with a nozzle or other shaping tools to control the shape and thickness of the extruded layer.

The control unit is an electronic system or device that controls and coordinates the operation of the entire system. The control unit receives input from various sensors and user interfaces
25 and uses this information to regulate the pumps, mixing chamber, and extruder. It ensures precise control over different operational parameters, for example flow rates and/or pressure of the cementitious material and/or of the additives of the cementitious materials, mixing ratios, and extrusion speed. An example of a control unit is a programmable logic controller (PLC).

The proposed invention also comprises, in a manner not known, that the extruder comprises
30 at least one temperature sensor, and in that the mixing chamber comprises at least one pressure sensor at the cementitious material inlet, each sensor being operatively connected in

closed loop to the control unit, which is configured to adjust the amount of additive for cementitious material in the printing composition based on the pressure and temperature measured by said sensors.

5 The system of the present invention allows a better control of the properties of the printing composition, which results in an increased quality of the printed material and an increased efficiency of the printing process as the controlled printing composition allows for a faster set of the printing composition, which allows to deposit a subsequent layer of printed composition faster.

10 According to the present invention, the mixing chamber may further comprise at least one temperature sensor at the cementitious material inlet, said temperature sensor being operatively connected in closed loop to the control unit, which is configured to determine a temperature differential between the temperature read at the extruder and the temperature read at the cementitious material inlet, and to adjust the amount of additive for cementitious material in the printing composition based on the pressure at the cementitious material inlet
15 and said temperature differential.

According to the present invention, the extruder may further comprise at least one pressure sensor operatively connected in closed loop to the control unit, which is configured to adjust the amount of additive for cementitious material in the printing composition also based on the reading of said pressure sensor.

20 According to the present invention, the system may further comprise a temperature and/or a pressure sensor at the supply line of additive for cementitious material, said temperature and/or pressure sensor being operatively connected in closed loop to the control unit, which is configured to adjust the amount of additive for cementitious material in the printing composition also based on the reading of said temperature and/or pressure sensor at the supply line of
25 additive for cementitious material.

According to the present invention, the mixing chamber may further comprise a motor-driven mixer. Preferably, the mixer comprises at least one blade for mixing the additive for cementitious material with the cementitious material to form the printing composition and to drive the printing composition towards the outlet of the extruder. Preferably, the at least one
30 blade is fixed in a removable manner to a driving shaft.

According to the present invention, the at least one pressure and the at least one temperature sensor of the extruder may be located downstream of the motor-driven mixer and upstream of the outlet of the extruder.

5 According to the present invention, the motor driven mixer may be configured to rotate with a variable rotation speed and the control unit may be configured to adjust the rotation speed of the motor driven mixer based on the pressure and temperature measured by the at least one pressure sensor and the at least one temperature sensor. Said at least one pressure sensor is preferably the at least one pressure sensor at the cementitious material inlet of the mixing chamber and said at least one temperature sensor is preferably the at least one temperature
10 sensor at the extruder.

According to the present invention, the mixing chamber and the extruder may be part of a printhead. Preferably, said printhead comprises two halves joined together in a non-permanent manner. This eases the cleaning and maintenance operations of the mixing chamber and the extruder, and components thereof.

15 According to the present invention, the inner surface of the mixing chamber and/or of the extruder may be substantially covered by a layer of an elastomeric material. Said layer of elastomeric material is preferably configured to prevent adhesion of the cementitious material, the additive for cementitious material and/or the printing composition to the inner walls of the mixing chamber and/or the extruder, so that maintenance and cleaning of the mixing chamber
20 and/or of the extruder is eased and correct operation of them is ensured during longer periods of time. Adhesion and/or setting of the cementitious material, the additive for cementitious material and/or the printing composition to the inner surfaces of the mixing chamber and/or the extruder should be avoided as it could affect the operation of the system, and in particular, it could affect the quality of the printed printing composition.

25 Preferably, said elastomeric material comprises polyurethane. Polyurethane maximizes the effect of prevention of adhesion of the cementitious material, the additive for cementitious material and/or the printing composition to the inner walls of the mixing chamber and/or of the extruder.

30 According to the present invention, the mixing chamber and/or the extruder may be made of stainless steel. In embodiments of the present invention wherein the mixing chamber and the extruder are part of a printhead, said printhead is preferably made of stainless steel.

According to the present invention, the at least one pump of cementitious material may comprise at least one progressive cavity pump. However, the at least one pump of cementitious material can also comprise other suitable kinds of pumps.

5 According to the present invention, the at least one pump of additive for cementitious material may comprise at least one peristaltic pump. Peristaltic pumps allow precise dosing of the additive for cementitious material. However, the at least one pump of additive for cementitious material can also comprise other suitable kinds of pumps.

10 According to the present invention, the system may comprise a first and a second pump of cementitious material, the first pump being connected to the second pump by a first section of the cementitious material supply line, and the second pump being connected to the cementitious material inlet of the mixing chamber by a second section of the cementitious material supply line. Preferably, the first section of the cementitious material supply line is configured to act as a buffer of cementitious material for the second pump, which is configured to dose cementitious material to the mixing chamber. This allows for a better control of the printing composition and, thus, for a better quality of the extruded cementitious material.

15 According to the present invention, the mixing chamber may comprise a second inlet of additive for cementitious material connected to a corresponding pump of additive for cementitious material.

20 According to the present invention, the system may further comprise a valve for opening and closing the outlet of the extruder. Preferably, said valve is a pinch valve.

The present invention also discloses a method for extruding cementitious material comprising the following steps:

- providing a system for extruding cementitious material as described in this document;
- pumping cementitious material to the mixing chamber with the at least one pump of cementitious material via the cementitious material supply line;
- pumping additive for cementitious material to the mixing chamber with the at least one pump of additive for cementitious material via the supply line of additive for cementitious material;

- mixing the cementitious material with the additive for cementitious material in the mixing chamber to form a printing composition;
- extruding at least one layer of the printing composition through an outlet of the extruder;
- measuring the temperature of the printing composition at the extruder with the at least one temperature sensor;
- measuring the pressure of the cementitious material at the cementitious material inlet with the at least one pressure sensor; and
- adjusting the amount of additive for cementitious material in the printing composition based on the temperature of the printing composition in the extruder and on the pressure of the cementitious material in the cementitious material inlet.

According to the present invention, the method may further comprise the steps of:

- measuring the temperature of the cementitious material at the cementitious material inlet with at least one temperature sensor;
- determining a temperature differential between the temperature of the printing composition in the extruder and the cementitious material in the cementitious material inlet;

wherein the step of adjusting the amount of additive for cementitious material in the printing composition is based on the temperature differential and on the pressure of the cementitious material in the cementitious material inlet.

- 20 According to the present invention, the method may further comprise the step of measuring the pressure of the printing composition at the extruder with at least one pressure sensor; and adjusting the amount of additive for cementitious material in the printing composition also based on the pressure of the printing composition at the extruder.

- 25 According to the present invention, the method may further comprise the steps of measuring the temperature and/or pressure of the additive for cementitious material at the supply line of additive for cementitious material with a temperature sensor and/or a pressure sensor; and adjusting the amount of additive for cementitious material in the printing composition also

based on the temperature and/or pressure of the additive at the supply line of additive for cementitious material.

According to the present invention, the step of mixing the cementitious material with the additive for cementitious material may comprise the step of turning a motor driven mixer of the
5 mixing chamber.

According to the present invention, the step of pumping cementitious material to the mixing chamber may comprise:

- pumping cementitious material with a first pump connected to a second pump by a first section of the cementitious material supply line; and
- 10 - pumping cementitious material with the second pump connected to the cementitious material inlet of the mixing chamber by a second section of the cementitious material supply line.

According to the present invention, the step of pumping cementitious material to the mixing chamber may further comprise:

- 15 - stretching the first section of the cementitious material supply line so that it acts as a buffer of cementitious material for the second pump; and
- dosing the cementitious material to the mixing chamber with the second pump.

According to the present invention, the step of pumping additive for cementitious material to the mixing chamber may comprise the steps of:

- 20 - pumping a first additive for cementitious material to the mixing chamber with a first pump of additive for cementitious material via a first supply line of additive for cementitious material connected to the first pump of additive for cementitious material and to a first inlet of additive for cementitious material of the mixing chamber.

According to the present invention, the step of pumping additive for cementitious material to
25 the mixing chamber may further comprise the steps of:

- pumping a second additive for cementitious material to the mixing chamber with a second pump of additive for cementitious material via a second supply line of additive for cementitious material connected to the second pump of additive for cementitious

material and to a second inlet of additive for cementitious material of the mixing chamber.

According to the present invention, the step of adjusting the amount of additive for cementitious material in the printing composition may comprise the step of adjusting the amount of additive
5 for cementitious material pumped by the at least one pump of additive for cementitious material.

According to the present invention, the step of adjusting the amount of additive for cementitious material in the printing composition may comprise the step of adjusting the amount of cementitious material pumped by the at least one pump of cementitious material.

10 According to the present invention, the step of adjusting the amount of additive for cementitious material in the printing composition may comprise the step of adjusting the rotation speed of the motor driven mixer.

The present invention also discloses a system for additive manufacturing of a cementitious material based structure comprising:

- 15
- a system for extruding cementitious material as described in this document;
 - a displacing unit for displacing at least the extruder of the system for extruding cementitious material along a printing path; and
 - a control unit for coordinating the system for extruding cementitious material with the displacing unit.

20 It will be understood that references to geometric position, such as parallel, perpendicular, tangent, etc. allow deviations up to $\pm 5^\circ$ from the theoretical position defined by this nomenclature.

It will also be understood that any range of values given may not be optimal in extreme values and may require adaptations of the invention to these extreme values are applicable, such
25 adaptations being within reach of a skilled person.

Brief description of the Figures

The foregoing and other advantages and features will be more fully understood from the following detailed description of an embodiment with reference to the accompanying drawings, to be taken in an illustrative and non-limitative manner, in which:

FIG. 1 shows a perspective view of an exemplary embodiment of a printhead of a system for
5 extruding cementitious material according to the present invention.

FIG. 2 shows a front view of the printhead shown in FIG. 1 but with its front half removed.

FIG. 3 shows a perspective view of the printhead shown in FIGS. 1 and 2 with its front half removed, as in FIG. 2.

FIG. 4 shows a diagram of a first exemplary embodiment of a system for extruding cementitious
10 material according to the present invention.

FIG. 5 shows a perspective view of a first exemplary embodiment of a system for additive manufacturing of a cementitious material based structure according to the present invention.

Detailed Description of the Invention and of particular embodiments

15 In FIG. 1 can be seen a perspective view of a printhead 1 of an exemplary embodiment of a system for extruding cementitious material according to the present invention. Said printhead 1 comprises in a single operating unit a mixing chamber 10 and an extruder 20 of a system for extruding cementitious material according to the present invention. However in other
20 embodiments said mixing chamber 10 and extruder 20 may not be part of a printhead 1, that is to say, both elements may be operatively connected, but physically separated. In particular, the mixing chamber 10 and the extruder 20 may be different elements of a system for extruding cementitious material according to the present intention, wherein the outlet of the mixing chamber 10 is fluidly connected to the inlet of the extruder 20 so that the printing composition coming out of the mixing chamber 10 can enter the extruder 20.

25 The arrangement of the mixing chamber 10 and the extruder 20 in a printhead 1 provides for a more compact arrangement, among other benefits.

The printhead 1 shown is preferably arranged in a vertical position (see for example, FIG. 5), that is to say, with its longitudinal axis perpendicular to the ground. However, it can also be arranged in other positions, for example, inclined.

Reference to positions like above, below, side, vertical, etc. will be referred with the printhead 1 in its position shown in the corresponding FIGS.

Upstream of the mixing chamber 10, and in the present exemplary embodiment, above it, the printing head 1 comprises a cementitious material inlet 11. The cementitious material is the
5 main component of the printing composition that will subsequently be extruded by the extruder 20. The inlet 12 of additive for cementitious material is located downstream the inlet 11 for cementitious material (see FIGS. 2 and 3).

The printhead 1, and in particular the outer casing thereof, comprises two halves 1A, 1B that are closed in a non-permanent manner by closing means 13, which can also be referred to as
10 closing mechanism. Having two halves 1A, 1B closed in a non-permanent manner allows for easier cleaning and maintenance of the printhead, and in particular, allows for an easier cleaning and maintenance of the inner surfaces and components of the mixing chamber 10 and extruder 20.

Even though the two parts of the of the printhead 1 are described with the nouns halves 1A, 1B, this does not mean that each part is exactly 50% of the printhead 1. For example, it is
15 possible that the removable half 1B represents less than half of the volume of the printhead 1 (e.g. 40%), or the opposite, that is to say, that the non-removable half 1A represents less than 50% of the volume of the printhead 1 (e.g. 45%).

In the exemplary embodiment shown, the closing means 13 comprise four threaded rods
20 hinged to the half 1A and corresponding nuts that press and hold both halves 1A, 1B, one against the other. However, in other embodiments said closing means 13 may be different than the ones of the exemplary embodiment shown, for example, said closing means 13 can comprise clamps, screws, etc.

Downstream the extruder 20, and in particular, downstream the outlet 21 thereof (see FIGS. 2
25 and 3), the printhead 1 of the exemplary embodiment shown comprises a valve 22 for opening and closing said outlet 21 of the extruder. In this exemplary embodiment, said valve 22 is a pinch valve, although other suitable kinds of valves can also be used. Said valve 22 is optional and other embodiments of a system for extruding cementitious material according to the present invention can lack it.

30 Downstream the valve 22, the printhead 1 of the exemplary embodiment shown comprises an outlet pipe 23 of the extruder 20 configured to guide the printing composition from the extruder

20 to the place where the printing composition is extruded. Said outlet pipe 23 is optional and other embodiments of a system for extruding cementitious material according to the present invention can lack it.

Protruding from the upper part of the mixing chamber 10, the printhead 1 of this exemplary
5 embodiment comprises a motor 41 that drives a motor driven mixer 40 (see FIGS. 2 and 3).

FIGS. 2 and 3 show a front and a perspective view, respectively, of the printhead 1 shown in FIG. 1, but with its front half 1B removed, so that inner components of the printhead 1 are visible. In this exemplary embodiment, the cementitious material inlet 11 is fluidly connected with a mixing space 15 of the mixing chamber 10 by an intake duct 14. In this exemplary
10 embodiment, said intake duct 14 comprises an inlet 12 for additive for cementitious material, a pressure sensor P1 at the cementitious material inlet 11 and a temperature sensor T2 at the cementitious material inlet 11. Even though said sensors P1, T2 are not located exactly at the cementitious material inlet 11, the pressure and temperature differential between their actual location shown in FIGS. 2 and 3 and the inlet 11 for cementitious material as such is negligible.

15 In operation of the exemplary embodiment shown, the cementitious material entering the mixing chamber 10 by the inlet 11 already encounters at the intake duct the additive for cementitious material entering by the inlet 12, and thus, both components start mixing. However, the mixture of the cementitious material with the additive for cementitious material substantially takes place in the mixing space 15. In order to enhance and homogenize the
20 mixture of cementitious material with additive for cementitious material, which is also known as printing composition, the exemplary embodiment shown further comprises a motor driven mixer 40 that comprises a driving shaft 43, driven by a motor 41, that comprises one or more blades 42 for mixing the additive for cementitious material with the cementitious material to form the printing composition and to drive the printing composition towards the outlet 21 of the
25 extruder 20. In this exemplary embodiment, the blades 42 are removable, that is to say, can be removed from the driving shaft 43, so that the blades 42 and the driving shaft can be easily cleaned. Using removable blades 42 also allows changing the geometry of the blades 42 depending on the desired properties of the printing composition and/or on the properties of the cementitious material and/or of the additive for cementitious material. In other embodiments
30 comprising a motor driven mixer 40 having blades 42, said blades may be non-removable. It is also possible that a motor driven mixer 40 comprises both removable and non-removable blades 42.

The mixture of the cementitious material with the additive for cementitious material can also be enhanced by the geometry of the mixing chamber, and in particular, by the geometry of the mixing space 15, among others.

In the exemplary embodiment shown, the extruder 20 comprises a temperature sensor T1 and a pressure sensor P2. Moreover, as stated above, in this exemplary embodiment, the mixing chamber 10 comprises a temperature sensor T2 and a pressure sensor P1 at the cementitious material inlet 11. The temperature sensor T1, the pressure sensor P1, the temperature sensor T2 and the pressure sensor P2 are operatively connected in closed loop to a control unit (not shown), which is configured to adjust the amount of additive for cementitious material in the printing composition based on the readings of said sensors. In order to do so, the control unit can adjust the flow rate and pressure of the cementitious material entering by the inlet 11 of cementitious material, the flow rate and pressure of the additive for cementitious material entering by the inlet 12 of additive for cementitious material and the rotation speed of the motor driven mixer 40. Although the printhead 1 of this exemplary embodiment comprises said four sensors T1, T2, P1, P2, in other embodiments, the temperature sensor T1 and the pressure sensor P1 can suffice. However, the greater the number of sensors, the greater the adjustment of the properties of the printing composition that can be obtained.

As can be seen, in this particular exemplary embodiment, the mixing space 15 and the extruder 20 are shaped substantially similar to an inverted bottle. In particular, the mixing space 15 is of a substantially cylindrical shape and the extruder 20 located downstream and contiguous to said mixing space 15 narrows towards the outlet 21 of the extruder 20. This shape aids in the mixing of the cementitious material with the additive for cementitious material and in driving the printing composition, resulting from mixing the cementitious material with the additive for cementitious material, towards the outlet 21 of the extruder 20.

In the exemplary embodiment shown, the inner surfaces of the mixing chamber 10 and the extruder 20 are covered by a layer 50 of elastomeric material. In the particular embodiment shown, the layer 50 comprises polyurethane, although in other embodiments the layer 50 can comprise other suitable materials. Said layer 50 of elastomeric material can be made of a single material or comprise two or more layers of different materials. The layer 50 of this exemplary embodiment is removable, although in other embodiments may be fixed. A removable layer 50 has the advantage of being easier to clean and that the maintenance time can be reduced as it can be replaced by another, clean or new, one while the one that was in use is being cleaned.

The layer 50 is configured to prevent adhesion of the cementitious material, the additive for cementitious material and/or the printing composition to the inner walls of the mixing chamber 10 and the extruder 20. The mixing chamber 10 and the extruder 20 of the exemplary embodiment shown are preferably made of stainless steel.

- 5 Said layer 50 has orifices, cut-outs, etc, so as not to block the sensors T1, P1, T2, P2 or the inlets 11, 12 or outlet 21.

At the peripheral regions thereof, and in particular, at its longitudinal borders, the layer 50 of elastomeric material comprises a sealing protrusion 51, that together with a corresponding sealing recess in the layer 50 of the other half of the printhead 1, provide a sealing arrangement
10 preventing leakage of the printing composition, cementitious material and/or additive for cementitious material. The sealing protrusion 51 and the corresponding sealing recess are preferably of matching shapes. Although they are preferred, in other embodiments having a layer 50 of elastomeric material said layer can lack such protrusions 51 and recesses.

FIG. 4 shows a schematic view of a first exemplary embodiment of a system for extruding
15 cementitious material according to the present invention. In this exemplary embodiment, a first pump 30 of cementitious material pumps cementitious material from a storage 35 of cementitious material to the mixing chamber 10 via a cementitious material supply line 32.

Said cementitious material supply line 32 comprises a first section 320, from the first pump 30 of cementitious material to a second pump 34 of cementitious material, and a second section
20 321, from the second pump 34 of cementitious material to the mixing chamber 10, and in particular, its inlet 11 for cementitious material. With this arrangement of two pumps 30, 34 defining two sections 320, 321 of the supply line 32 of cementitious material, if the supply line is a flexible tube or hose, the first section 320 can be stretched, i.e. the first section 320 can be contracted or expanded, thereby acting as a buffer of cementitious material for the second
25 pump 34 which is configured to provide the exact dose of cementitious material determined by the control unit (not shown) of the system. In order to ensure optimal operation of the first section 320 as a buffer, in this first exemplary embodiment said first section 320 comprises two pressure sensors P4, P5, although they are optional. This particular embodiment further comprises two valves V1, V2, that are also optional and, for example, can relieve pressure of
30 the first section 320 if one of the sensors P4, P5 detects an overpressure.

Although the exemplary embodiment shown has been depicted with two pumps 30, 34 of cementitious material and two sections of cementitious material supply line 32, other embodiments can comprise a single pump 30, 34 of cementitious material and a single section 320, 321 of cementitious material supply line 32.

- 5 Downstream the second pump 34 of cementitious material, the embodiment shown comprises a pressure sensor P1 and a temperature sensor T2 at the cementitious material inlet 11 (see FIGS. 1 to 3). Said temperature sensor T2 is optional and other embodiments of the present invention may lack it.

The pressure of the printing composition at the outlet 21 of the extruder 20 (see FIGS. 2 and
10 3) can be adjusted by adjusting the at least one pump 30, 34 of cementitious material and/or the rotation speed of the motor driven mixer 40, in embodiments having these elements. The combination of the at least one pump 30, 34 of cementitious material with the motor driven mixer 40 provides a finer adjustment of the pressure of the printing composition at the outlet 21 of the extruder 20. In embodiments lacking a motor driven mixer 40 the pressure of the
15 printing composition at the outlet 21 of the extruder 20 is regulated by adjusting the at least one pump 30, 34 of cementitious material.

FIG. 4 also illustrates a storage 36 of additive for additive of cementitious material from which a pump 31 for additive of cementitious material pumps said additive to the mixing chamber 10 by a supply line 33 of additive for cementitious material so that it is mixed with the cementitious
20 material thereby forming the printing composition. In this exemplary embodiment, downstream the pump 31, the supply line 33 comprises a temperature T3 and a pressure sensor P3 of said supply line 33 of additive for cementitious material. Downstream the storage 36, and upstream the pump 31, the supply line 33 of this exemplary embodiment comprises a valve V3 for purging said supply line 33, among other possibilities. The temperature sensor T3, the
25 pressure sensor P3 and the valve V3 are optional elements of the system and other embodiments of the present invention may lack one, two or the three of them.

In embodiments like the one shown in FIG. 4 wherein the system comprises a temperature sensor T1 at the extruder 20 and a temperature sensor T2 at the cementitious material inlet 11, the control unit can determine a temperature differential between both sensors and adjust
30 the amount of additive for cementitious material in the printing composition, i.e. the mixture of cementitious material with additive for cementitious material, in order to obtain the desired properties of the printing composition.

By adjusting the amount of additive for cementitious material in the printing composition, and in particular embodiments, even the type or types of additive, it is possible to adjust the properties of the printing composition. Ideally, the printing composition should have a high degree of extrudability, which is known as the capacity of a material to continuously pass
5 through the different elements of the system and, in particular, through the mixing chamber and extruder. Also ideally, the printing composition should have a high degree of buildability, which is known as the ability of a material to retain its extruded shape under self-weight and pressure from upper layers. The extruded printing composition should have sufficient
10 buildability to enable it to be extruded or deposited accurately, keep the form after extrusion or deposition and have sufficient strength to sustain the weight of further layers without collapsing and still provide a good bond between layers.

Typically, printing materials require a long setting time to maintain a consistent flow rate for good extrudability, where appropriate retarders are needed to control the setting time of the printing material. However, printing material also requires a short setting time to allow the
15 material to acquire enough strength after being deposited or extruded so that it is able to sustain the weight of further layers.

Although extrudability and buildability appear to be mutually exclusive, that is to say, a printing material having good buildability should have a low extrudability, and vice versa, with the use of appropriate additives, the present invention allows to obtain a control of the properties of the
20 printing composition so that a good balance between extrudability and buildability can be obtained and the additive manufacturing of a cementitious material based structure can be optimised.

FIG. 5 shows a perspective view of a first exemplary embodiment of a system 100 for additive manufacturing of a cementitious material based structure according to the present invention.
25 This system 100 for additive manufacturing comprises a system for extruding cementitious material according to the present invention, for example, the one schematically depicted in FIG. 4, a displacing unit 110 for displacing along a printing path at least the extruder 20 of the system for extruding cementitious material, and a control unit (not shown) for coordinating the system for extruding cementitious material with the displacing unit.

30 Said control unit for coordinating the system for extruding cementitious material with the displacing unit may be the same control unit of the system for extruding cementitious material or a different one.

In order to simplify the drawing, in FIG. 5 only a printhead 1, similar to the one depicted in FIGS. 1 to 3, is shown from the system for extruding cementitious material. In other embodiments, the system for additive manufacturing of a cementitious material based structure can comprise any system for extruding cementitious material according to the present invention.

- 5 In this exemplary embodiment, the displacing unit 110 of the system 100 comprises a pair of longitudinal guides 111 that allow movement of the printhead 1, or at least of the extruder, along the X axis; one transversal guide 112 that allows movement of the printhead 1, or at least of the extruder, along the Y axis; and a pair of vertical guides 113 that allow movement of the printhead 1, or at least of the extruder, along the Z axis. This particular arrangement of
10 longitudinal 111, transversal 112 and vertical 113 guides may be different in other embodiments of the present invention.

Thanks to the displacing unit 110 shown, the printhead 1 can be moved along the space, that is to say, in a three-dimensional volume, depositing at least one layer of cementitious material or printing composition to form a cementitious material based structure.

- 15 Unless otherwise provided, features described in relation to a certain exemplary embodiment are also applicable to other embodiments of the present invention.

CLAIMS

1. System for extruding cementitious material comprising:

- at least one pump (30, 34) of cementitious material;
 - at least one pump (31) of additive for cementitious material;
- 5 - a mixing chamber (10) comprising a cementitious material inlet (11) connected to the at least one pump (30, 34) of cementitious material via a cementitious material supply line (32), and an inlet (12) of additive for cementitious material connected to the at least one pump (31) of additive for cementitious material via a supply line (33) of additive for cementitious material; said mixing chamber (10) being configured to mix the
- 10 cementitious material with the additive for cementitious material, thereby forming a printing composition;
- an extruder (20) for extruding at least one layer of the printing composition through an outlet (21) thereof;
 - a control unit for controlling the aforementioned elements of the system;
- 15 wherein the extruder (20) comprises at least one temperature sensor (T1), and in that the mixing chamber (10) comprises at least one pressure sensor (P1) at the cementitious material inlet (11), each sensor being operatively connected in closed loop to the control unit, which is configured to adjust the amount of additive for cementitious material in the printing composition based on the pressure and temperature measured by said sensors;
- 20 characterized in that the system comprises a first (30) and a second pump (34) of cementitious material, the first pump (30) being connected to the second pump (34) by a first section (320) of the cementitious material supply line (32), and the second pump (34) being connected to the cementitious material inlet (11) of the mixing chamber (10) by a second section (321) of the cementitious material supply line (32), and wherein the first section (320) of the
- 25 cementitious material supply line (32) is configured to act as a buffer of cementitious material for the second pump (34), which is configured to dose cementitious material to the mixing chamber (10).

2. System, according to claim 1, wherein the mixing chamber (10) further comprises at least one temperature sensor (T2) at the cementitious material inlet (11), said temperature sensor

(T2) being operatively connected in closed loop to the control unit, which is configured to determine a temperature differential between the temperature read at the extruder (20) and the temperature read at the cementitious material inlet (11), and to adjust the amount of additive for cementitious material in the printing composition based on the pressure at the cementitious material inlet (11) and said temperature differential.

3. System, according to claim 1 or 2, wherein the extruder (20) further comprises at least one pressure sensor (P2) operatively connected in closed loop to the control unit, which is configured to adjust the amount of additive for cementitious material in the printing composition also based on the reading of said pressure sensor (P2).

4. System, according to any one of the preceding claims, further comprising a temperature (T3) and/or a pressure sensor (P3) at the supply line (33) of additive for cementitious material, said temperature (T3) and/or pressure sensor (P3) being operatively connected in closed loop to the control unit, which is configured to adjust the amount of additive for cementitious material in the printing composition also based on the reading of said temperature (T3) and/or pressure sensor (P3) at the supply line (33) of additive for cementitious material.

5. System, according to any one of the preceding claims, wherein the mixing chamber (10) further comprises a motor-driven mixer (40), which comprises at least one blade (42) for mixing the additive for cementitious material with the cementitious material to form the printing composition and to drive the printing composition towards the outlet (21) of the extruder (20), and wherein the motor driven mixer (40) is configured to rotate with a variable rotation speed and the control unit is configured to adjust the rotation speed of the motor driven mixer (40) based on the pressure and temperature measured by the at least one pressure sensor (P1) and the at least one temperature sensor (T1).

6. System, according to any one of the preceding claims, wherein the mixing chamber (10) and the extruder (20) are part of a printhead (1), which comprises two halves (1A, 1B) joined together in a non-permanent manner.

7. System, according to any one of the preceding claims, wherein the inner surface of the mixing chamber (10) and/or of the extruder (20) is substantially covered by a layer of an elastomeric material.

8. Method for extruding cementitious material comprising the steps of:

- providing a system for extruding cementitious material according to any one of claims 1 to 7;
- 5 - pumping cementitious material to the mixing chamber (10) with the at least one pump (30, 34) of cementitious material via the cementitious material supply line (32);
- pumping additive for cementitious material to the mixing chamber (10) with the at least one pump (31) of additive for cementitious material via the supply line (33) of additive for cementitious material;
- 10 - mixing the cementitious material with the additive for cementitious material in the mixing chamber (10) to form a printing composition;
- extruding at least one layer of the printing composition through an outlet (21) of the extruder (20);
- measuring the temperature of the printing composition at the extruder (20) with the at least one temperature sensor (T1);
- 15 - measuring the pressure of the cementitious material at the cementitious material inlet (11) with the at least one pressure sensor (P1); and
- adjusting the amount of additive for cementitious material in the printing composition based on the temperature of the printing composition in the extruder (20) and on the pressure of the cementitious material in the cementitious material inlet (11);
- 20 characterized in that the step of pumping cementitious material to the mixing chamber (10) comprises:
 - pumping cementitious material with a first pump (30) connected to a second pump (34) by a first section (320) of the cementitious material supply line (32);
 - 25 - stretching the first section (320) of the cementitious material supply line (32) so that it acts as a buffer of cementitious material for the second pump (34);

- pumping cementitious material with the second pump (34) connected to the cementitious material inlet (11) of the mixing chamber (10) by a second section (321) of the cementitious material supply line (32); and
- dosing the cementitious material to the mixing chamber (10) with the second pump (34).

9. Method, according to claim 8, further comprising the steps of:

- measuring the temperature of the cementitious material at the cementitious material inlet (11) with at least one temperature sensor (T2);
- determining a temperature differential between the temperature of the printing composition in the extruder (20) and the cementitious material in the cementitious material inlet (11);

wherein the step of adjusting the amount of additive for cementitious material in the printing composition is based on the temperature differential and on the pressure of the cementitious material in the cementitious material inlet (11).

10. Method, according to claim 8 or 9, further comprising the step of measuring the pressure of the printing composition at the extruder (20) with at least one pressure sensor (P2); and adjusting the amount of additive for cementitious material in the printing composition also based on the pressure of the printing composition at the extruder (20).

11. Method, according to any one of claims 8 to 10, further comprising the steps of measuring the temperature and/or pressure of the additive for cementitious material at the supply line (33) of additive for cementitious material with a temperature sensor (T3) and/or a pressure sensor (P3); and adjusting the amount of additive for cementitious material in the printing composition also based on the temperature and/or pressure of the additive at the supply line (33) of additive for cementitious material.

12. Method, according to any one of claims 8 to 11, wherein the step of mixing the cementitious material with the additive for cementitious material comprises the step of turning a motor driven mixer (40) of the mixing chamber (10); and wherein the step of adjusting the amount of additive for cementitious material in the printing composition comprises the step of adjusting the rotation speed of the motor driven mixer (40).

13. System (100) for additive manufacturing of a cementitious material based structure comprising:

- a system for extruding cementitious material according to any one of claims 1 to 7;
- a displacing unit (110) for displacing at least the extruder (20) of the system for extruding cementitious material along a printing path; and
- a control unit for coordinating the system for extruding cementitious material with the displacing unit (110).

DRAWINGS

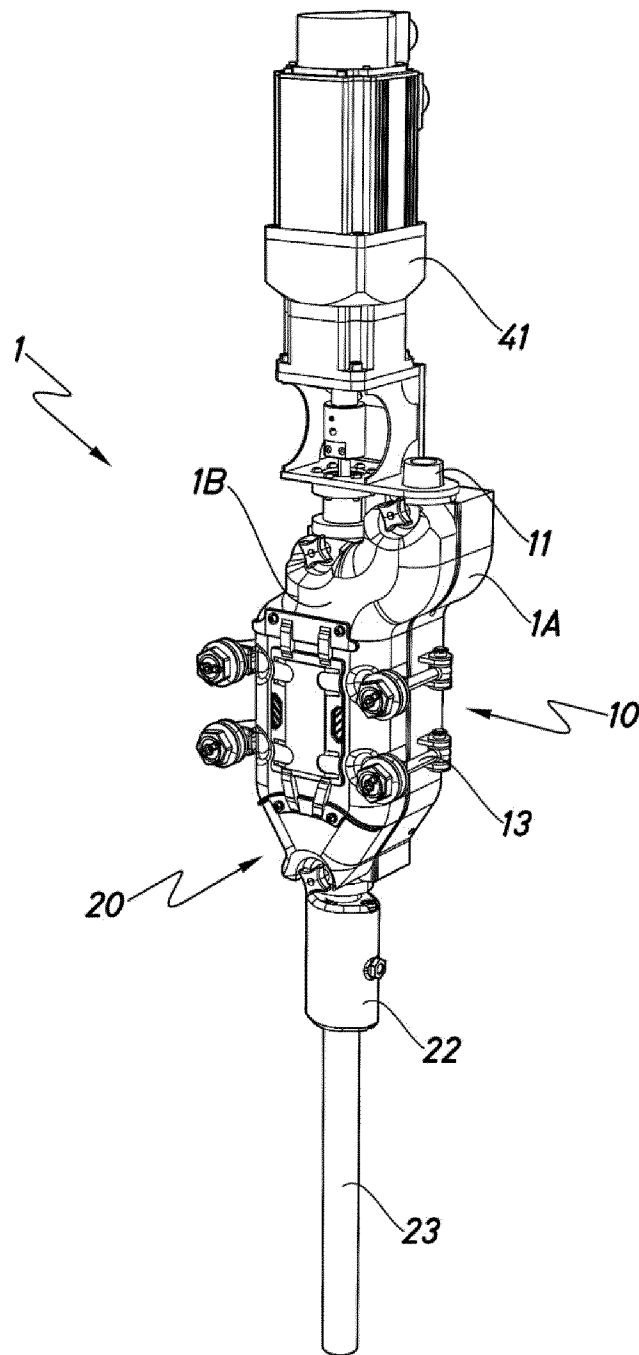

Fig.1

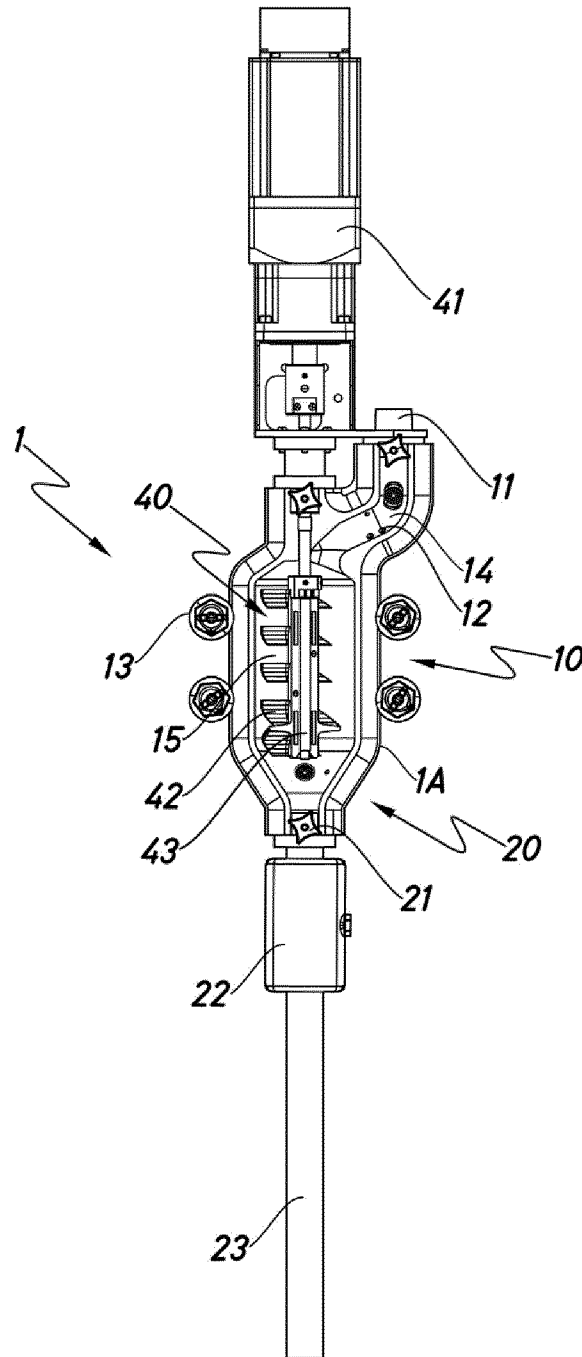

Fig.2

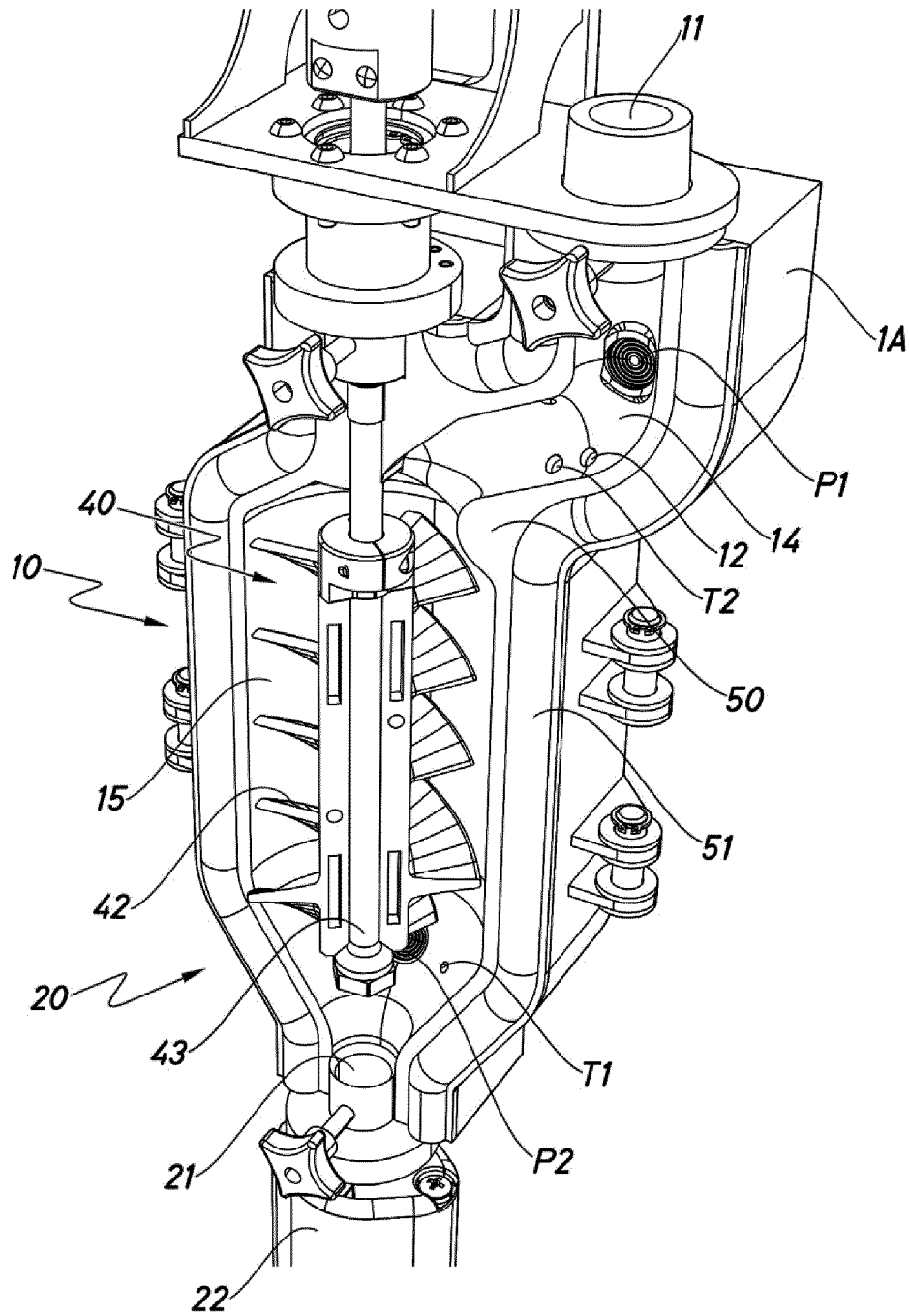

Fig.3

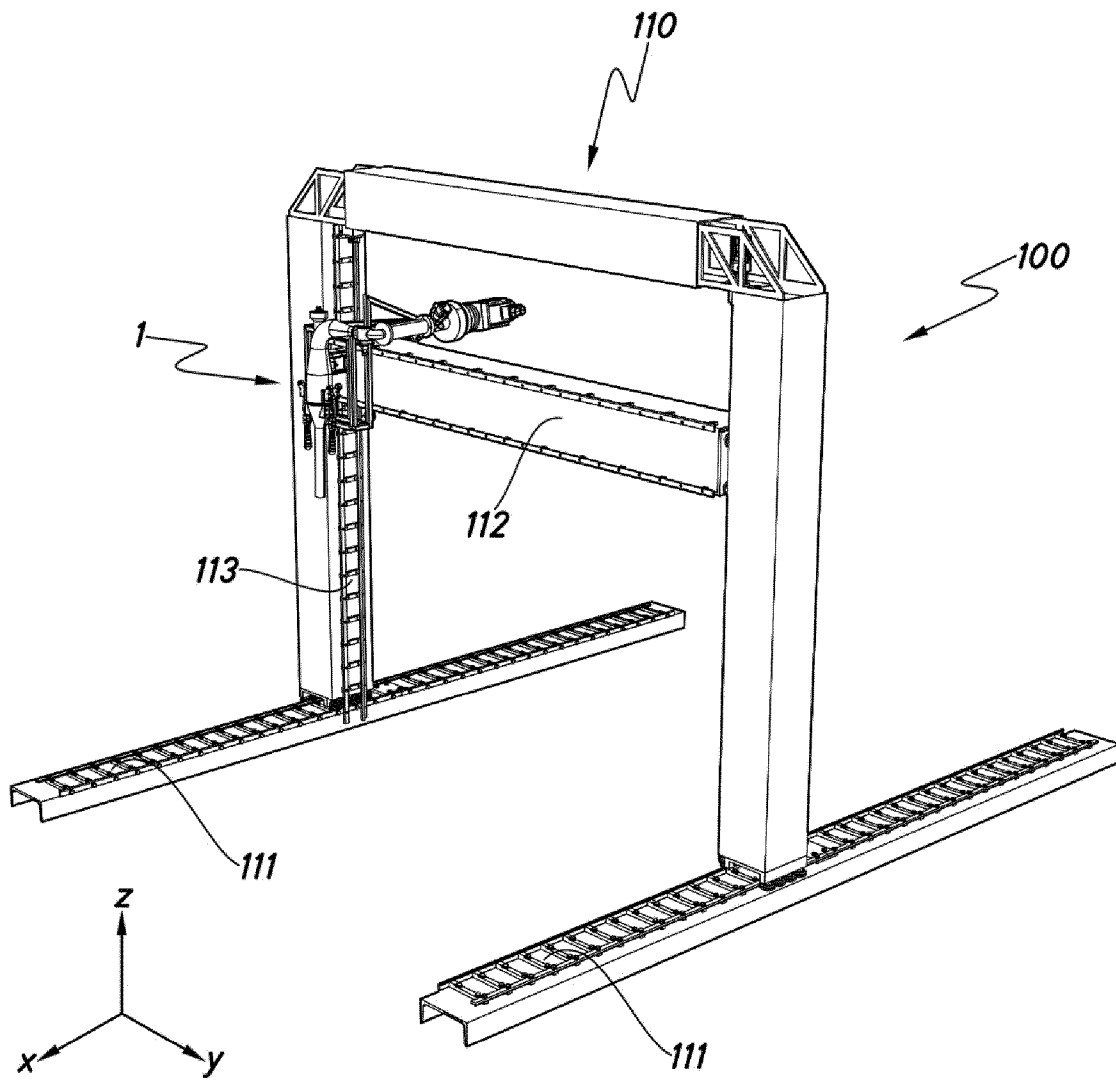

Fig.5

INTERNATIONAL SEARCH REPORT

International application No
PCT/EP2024/067273

A. CLASSIFICATION OF SUBJECT MATTER
 INV. B28B1/00 B28C7/02 B28C5/08
 ADD.

According to International Patent Classification (IPC) or to both national classification and IPC

B. FIELDS SEARCHED
 Minimum documentation searched (classification system followed by classification symbols)
B28B B28C

Documentation searched other than minimum documentation to the extent that such documents are included in the fields searched

Electronic data base consulted during the international search (name of data base and, where practicable, search terms used)
EPO- Internal

C. DOCUMENTS CONSIDERED TO BE RELEVANT

Category*	Citation of document, with indication, where appropriate, of the relevant passages	Relevant to claim No.
A	EP 3 708 320 A1 (SIKA TECH AG [CH]) 16 September 2020 (2020-09-16) paragraph [0080] - paragraph [0085] paragraphs [0093], [0103] paragraph [0197] - paragraph [0238]; claims; figure 1 -----	1 - 13
A	CN 116 122 584 A (UNIV TONGJI) 16 May 2023 (2023-05-16) the whole document -----	1 - 13
A	FR 3 125 458 A1 (VICAT [FR]) 27 January 2023 (2023-01-27) paragraph [0068] - paragraph [0074]; figures paragraph [0121] - paragraph [0125] ----- - / - -	1 - 13

Further documents are listed in the continuation of Box C. See patent family annex.

* Special categories of cited documents :

"A" document defining the general state of the art which is not considered to be of particular relevance	"T" later document published after the international filing date or priority date and not in conflict with the application but cited to understand the principle or theory underlying the invention
"E" earlier application or patent but published on or after the international filing date	"X" document of particular relevance; the claimed invention cannot be considered novel or cannot be considered to involve an inventive step when the document is taken alone
"L" document which may throw doubts on priority claim(s) or which is cited to establish the publication date of another citation or other special reason (as specified)	"Y" document of particular relevance; the claimed invention cannot be considered to involve an inventive step when the document is combined with one or more other such documents, such combination being obvious to a person skilled in the art
"O" document referring to an oral disclosure, use, exhibition or other means	"&" document member of the same patent family
"P" document published prior to the international filing date but later than the priority date claimed	

Date of the actual completion of the international search 5 September 2024	Date of mailing of the international search report 12/09/2024
--	---

Name and mailing address of the ISA/ European Patent Office, P.B. 5818 Patentlaan 2 NL - 2280 HV Rijswijk Tel. (+31-70) 340-2040, Fax: (+31-70) 340-3016	Authorized officer Orij, Jack
--	---

INTERNATIONAL SEARCH REPORT

International application No
PCT/EP2024/067273

C(Continuation). DOCUMENTS CONSIDERED TO BE RELEVANT		
Category*	Citation of document, with indication, where appropriate, of the relevant passages	Relevant to claim No.
A	FR 3 088 569 A1 (XTREEE [FR]) 22 May 2020 (2020-05-22) page 12, line 25 - page 14, line 21; figures 1,2 -----	1 - 13

INTERNATIONAL SEARCH REPORT

Information on patent family members

International application No

PCT/EP2024/067273

Patent document cited in search report	Publication date	Patent family member(s)	Publication date
EP 3708320	A1	16-09-2020	BR 112021013972 A2
			CL 2021001900 A1
			CO 2021013338 A2
			EP 3708320 A1
			EP 3938160 A1
			EP 4316760 A2
			SG 11202107330S A
			US 2022152868 A1
			WO 2020187635 A1

CN 116122584	A	16-05-2023	NONE

FR 3125458	A1	27-01-2023	EP 4373648 A1
			FR 3125458 A1
			WO 2023002247 A1

FR 3088569	A1	22-05-2020	EP 3674045 A1
			ES 2894236 T3
			FR 3088569 A1
