



(51) International Patent Classification:

C07C 255/51 (2006.01) C09K 11/06 (2006.01)
C07D 235/18 (2006.01) H01L 51/50 (2006.01)

(21) International Application Number:

PCT/JP2013/070127

(22) International Filing Date:

18 July 2013 (18.07.2013)

(25) Filing Language:

English

(26) Publication Language:

English

(30) Priority Data:

2012-174880 7 August 2012 (07.08.2012) JP

(71) Applicant: CANON KABUSHIKI KAISHA [JP/JP]; 30-2, Shimomaruko 3-chome, Ohta-ku, Tokyo, 1468501 (JP).

(72) Inventors: TAGAMI, Kei; C/O CANON KABUSHIKI KAISHA, 30-2, Shimomaruko 3-chome, Ohta-ku, Tokyo, 1468501 (JP). OHRUI, Hiroki; C/O CANON KABUSHIKI KAISHA, 30-2, Shimomaruko 3-chome, Ohta-ku, Tokyo, 1468501 (JP). IWAWAKI, Hironobu; C/O CANON KABUSHIKI KAISHA, 30-2, Shimomaruko 3-chome, Ohta-ku, Tokyo, 1468501 (JP). ITABASHI, Masumi; C/O CANON KABUSHIKI KAISHA, 30-2, Shimomaruko 3-chome, Ohta-ku, Tokyo, 1468501 (JP). TAKAHASHI, Tetsuo; C/O CANON KABUSHIKI KAISHA, 30-2, Shimomaruko 3-chome, Ohta-ku, Tokyo, 1468501 (JP). IKARI, Kenichi; C/O CANON KABUSHIKI KAISHA, 30-2, Shimomaruko 3-chome, Ohta-ku, Tokyo, 1468501 (JP). ISHII, Ryuji; C/O CANON KABUSHIKI KAISHA, 30-2, Shimomaruko 3-chome,

Ohta-ku, Tokyo, 1468501 (JP). MURATSUBAKI, Masanori; C/O CANON KABUSHIKI KAISHA, 30-2, Shimomaruko 3-chome, Ohta-ku, Tokyo, 1468501 (JP).

(74) Agents: ABE, Takuma et al.; C/O CANON KABUSHIKI KAISHA, 30-2, Shimomaruko 3-chome, Ohta-ku, Tokyo, 1468501 (JP).

(81) Designated States (unless otherwise indicated, for every kind of national protection available): AE, AG, AL, AM, AO, AT, AU, AZ, BA, BB, BG, BH, BN, BR, BW, BY, BZ, CA, CH, CL, CN, CO, CR, CU, CZ, DE, DK, DM, DO, DZ, EC, EE, EG, ES, FI, GB, GD, GE, GH, GM, GT, HN, HR, HU, ID, IL, IN, IS, KE, KG, KN, KP, KR, KZ, LA, LC, LK, LR, LS, LT, LU, LY, MA, MD, ME, MG, MK, MN, MW, MX, MY, MZ, NA, NG, NI, NO, NZ, OM, PA, PE, PG, PH, PL, PT, QA, RO, RS, RU, RW, SC, SD, SE, SG, SK, SL, SM, ST, SV, SY, TH, TJ, TM, TN, TR, TT, TZ, UA, UG, US, UZ, VC, VN, ZA, ZM, ZW.

(84) Designated States (unless otherwise indicated, for every kind of regional protection available): ARIPO (BW, GH, GM, KE, LR, LS, MW, MZ, NA, RW, SD, SL, SZ, TZ, UG, ZM, ZW), Eurasian (AM, AZ, BY, KG, KZ, RU, TJ, TM), European (AL, AT, BE, BG, CH, CY, CZ, DE, DK, EE, ES, FI, FR, GB, GR, HR, HU, IE, IS, IT, LT, LU, LV, MC, MK, MT, NL, NO, PL, PT, RO, RS, SE, SI, SK, SM, TR), OAPI (BF, BJ, CF, CG, CI, CM, GA, GN, GQ, GW, KM, ML, MR, NE, SN, TD, TG).

Published:

— with international search report (Art. 21(3))

(54) Title: NOVEL FUSED POLYCYCLIC COMPOUND AND ORGANIC LIGHT-EMITTING DEVICE, DISPLAY APPARATUS, IMAGE INFORMATION PROCESSING APPARATUS, LIGHTING SYSTEM, AND IMAGE FORMING APPARATUS HAVING THE COMPOUND

FIG. 1

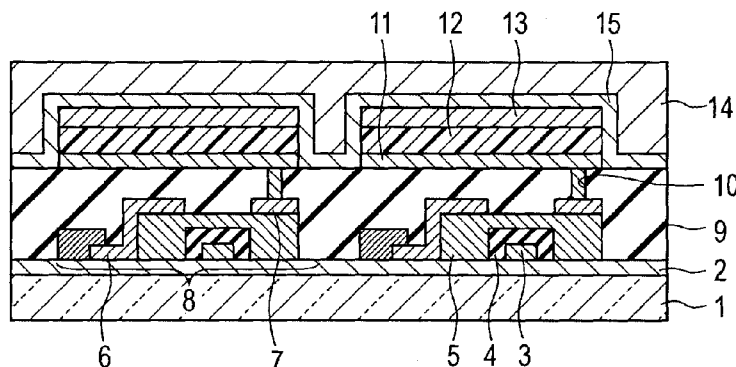

(57) Abstract: A novel organic compound suitable for blue-light-emitting devices and an organic light-emitting device including the compound are provided. An organic compound represented by Formula [1] according to Claim 1 is provided. In Formula [1], R₁ to R₁₆ each independently represent a group selected from a hydrogen atom, a cyano group, substituted or unsubstituted alkyl groups, substituted or unsubstituted aryl groups, and substituted or unsubstituted heterocyclic groups.



DESCRIPTION

NOVEL FUSED POLYCYCLIC COMPOUND AND ORGANIC LIGHT-EMITTING DEVICE, DISPLAY APPARATUS, IMAGE INFORMATION PROCESSING APPARATUS, LIGHTING SYSTEM, AND IMAGE FORMING APPARATUS HAVING THE COMPOUND

Technical Field

[0001] The present invention relates to a novel fused polycyclic compound and an organic light-emitting device, a display apparatus, an image information processing apparatus, a lighting system, and an image forming apparatus each including the compound.

Background Art

[0002] Organic light-emitting devices each have a pair of electrodes and an organic compound layer containing a fluorescent or phosphorescent organic compound disposed between the electrodes, generate excitons of the fluorescent or phosphorescent organic compound by injection of electrons and holes from the electrodes, and utilize the light emitted when the excitons return to the ground state.

[0003] In recent organic light-emitting devices, low driving voltages, high luminance, various emission wavelengths, rapid response, and reductions in size and weight are possible, and wide application of the light-

emitting devices is suggested.

[0004] PTL 1 describes naphtho[2,3-k]fluoranthene as a compound for organic EL devices. PTL 2 describes naphthofluoranthene as a light-emitting material for organic electroluminescent devices.

[0005] Naphtho[2,3-k]fluoranthene described in PTL 1 has a peak emission wavelength of 470 nm, which is the longer wavelength side as a blue light, and is therefore an undesirable compound as a blue light-emitting material.

[0006] Naphthofluoranthene described in PTL 2 has a small difference between the first and second peak emission wavelengths, resulting in a low color purity of light emission.

[0007] The organic compounds and the organic light-emitting devices using the compounds described in these patent documents need to be further improved, from the viewpoint of practical application.

[0008] Specifically, application to practical use requires a further increase in luminance of optical output or in conversion efficiency. Furthermore, in application to, for example, a full color display, the organic light-emitting device is required to emit blue light with a high color purity and a high efficiency. These issues have not sufficiently been resolved yet.

[0009] Though PTL 1 and PTL 2 describe light-emitting

materials used in organic light-emitting devices, there is a demand for a light-emitting material having a further high color purity and a further high efficiency.

Citation List

Patent Literature

[0010] PTL 1 Japanese Patent Laid-Open No. 2005-53806

PTL 2 Japanese Patent Laid-Open No. 10-294177

Summary of Invention

[0011] The present invention provides a novel fused polycyclic compound that emits blue light with a high color purity and a high luminous efficiency. The present invention provides an organic light-emitting device, a display apparatus, an image information processing apparatus, a lighting system, and an image forming apparatus each including the compound.

[0012] The present invention provides a fused polycyclic compound represented by the following Formula [1]:

[Chem. 1]

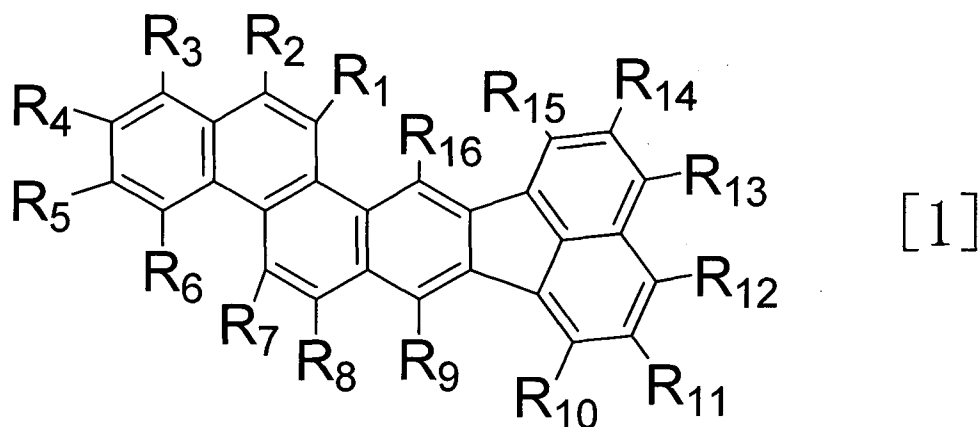

wherein R_1 to R_{16} each independently represent a group selected from a hydrogen atom, a cyano group, substituted or unsubstituted alkyl groups, substituted or unsubstituted aryl groups, and substituted or unsubstituted heterocyclic groups.

[0013] Further features of the present invention will become apparent from the following description of exemplary embodiments with reference to the attached drawings.

Advantageous Effects of Invention

[0014] The present invention can provide a novel fused polycyclic compound that emits blue light having a high color purity with a high luminous efficiency and also can provide an organic light-emitting device including the compound so as to have a high luminous efficiency and a long life.

Brief Description of Drawings

[0015] Fig. 1 is a schematic cross-sectional view illustrating an example of a display apparatus including an organic light-emitting device of the present invention and an active device connected to the organic light-emitting device.

Fig. 2 is a graph showing photoluminescence spectra of Example Compound D16 and Comparative Compound R_1 .

Description of Embodiment

[0016] The present invention relates to a fused polycyclic

compound represented by the following Formula [1]:

[Chem. 2]

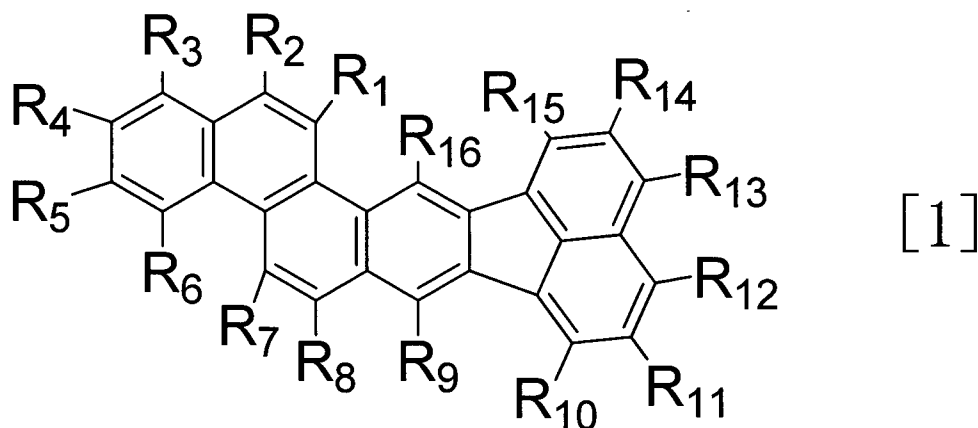

wherein R_1 to R_{16} each independently represent a group selected from a hydrogen atom, a cyano group, substituted or unsubstituted alkyl groups, substituted or unsubstituted aryl groups, and substituted or unsubstituted heterocyclic groups.

[0017] The fused polycyclic compound of the present invention is also called a acenaphtho[1,2-b]chrysene compound. Hereinafter, the fused polycyclic compound of the present invention is also called an acenaphtho[1,2-b]chrysene compound in the embodiment.

[0018] In Formula [1], at least two of R_2 , R_4 , R_8 , R_{12} , and R_{13} can be electron-withdrawing substituents.

[0019] In Formula [1], examples of the substituted or unsubstituted alkyl group include, but not limited to, methyl, ethyl, n-propyl, n-butyl, n-pentyl, n-hexyl, n-heptyl, n-octyl, n-decyl, iso-propyl, iso-butyl, sec-butyl,

tert-butyl, iso-pentyl, neopentyl, tert-octyl, fluoromethyl, difluoromethyl, trifluoromethyl, 2-fluoroethyl, 2,2,2-trifluoroethyl, perfluoroethyl, 3-fluoropropyl, perfluoropropyl, 4-fluorobutyl, perfluorobutyl, 5-fluoropentyl, 6-fluorohexyl, cyclopropyl, cyclobutyl, cyclopentyl, cyclohexyl, cyclopentylmethyl, cyclohexylmethyl, cyclohexylethyl, 4-fluorocyclohexyl, norbornyl, and adamantyl groups.

[0020] In Formula [1], examples of the aryl group include, but not limited to, phenyl, naphthyl, indenyl, biphenyl, terphenyl, fluorenyl, anthryl, phenanthryl, pyrenyl, tetracenyl, pentacenyl, triphenyl, and perylenyl groups.

[0021] In Formula [1], examples of the heterocyclic group include, but not limited to, thienyl, pyrrolyl, pyridyl, pyrazyl, pyrimidyl, pyridazinyl, quinolinyl, isoquinolinyl, oxazolyl, oxadiazolyl, phenanthridinyl, acridinyl, naphthyridinyl, quinoxalinyl, quinazolinyl, cinnolinyl, phthalazinyl, phenanthrolyl, phenazinyl, dibenzofuranyl, dibenzothiophenyl, carbazolyl, benzofuranyl, benzothiophenyl, indolyl, cycloazyl, benzoimidazolyl, benzothiazolyl, and benzothiadiazolyl groups.

[0022] In Formula [1], examples of the substituent, i.e., the substituent possessed by the alkyl group, the aryl group, or the heterocyclic group, include, but not limited to, alkyl groups such as methyl, ethyl, propyl, and butyl

groups; aralkyl groups such as a benzyl group; aryl groups such as phenyl and biphenyl groups; heterocyclic groups such as pyridyl, pyrrolyl, benzoimidazolyl, and benzothiazolyl groups; amino groups such as dimethylamino, diethylamino, dibenzylamino, diphenylamino, and ditolylamino groups; alkoxy groups such as methoxy, ethoxy, propoxy, and phenoxy groups; a cyano group; and halogen atoms such as fluorine, chlorine, bromine, and iodine.

[0023] In Formula [1], examples of the electron-withdrawing substituent include, but not limited to, cyano, nitro, alkylsulfonyl, halogenated alkyl, acyl, alkoxy carbonyl, sulfamoyl, carbamoyl, halogenated alkoxy, sulfonyloxy, halogenated alkylthio, benzoxazolyl, benzothiazolyl, benzimidazolyl, and oxazolopyridyl groups and halogen atoms.

[0024] In this embodiment, a basic skeleton refers to a structure formed of only fused rings. In the acenaphtho[1,2-b]chrysene compound of the present invention, the structure of the compound represented by Formula [1] and having all of R₁ to R₁₆ being hydrogen atoms corresponds to the basic skeleton of the present invention.

[0025] The luminous efficiency of an organic light-emitting device can be enhanced by increasing the light emission quantum efficiency of an organic compound of an emission center.

[0026] An organic compound having a high quantum efficiency is required to satisfy the following two requirements:

1. the oscillator strength is high, and
2. the number of oscillating portion of a skeleton involved in light emission is small.

Satisfaction of the requirement 1, i.e., a high oscillator strength leads to a high quantum efficiency.

[0027] In a skeleton having a high oscillator strength, the symmetry of the skeleton involved in light emission of a molecule is high. However, such a highly symmetric molecule may not emit light under the forbidden transition condition peculiar to the molecule.

[0028] The oscillator strength can also be improved by increasing the dipole moment of a molecule, the dipole moment being increased by further extending the conjugate using the longer direction of the conjugate plane as an axis.

[0029] The acenaphtho[1,2-b]chrysene compound of the present invention has a structure having a fused-ring in the direction extending the conjugate from the 10-position to the 11-position of naphtho[1,2-k]fluoranthene.

[0030] This structure allows the [1,2-b]chrysene compound of the present invention to have a further larger dipole moment than that of naphtho[1,2-k]fluoranthene and is a structure having a higher oscillator strength than that of

naphtho[1,2-k]fluoranthene.

[Chem. 3]

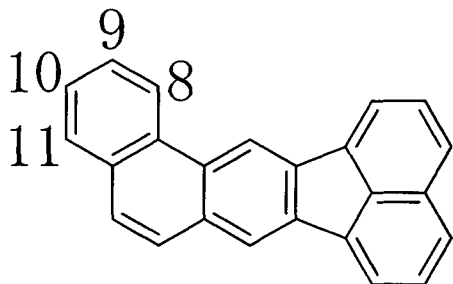

Naphtho[1,2-k]fluoranthene

[0031] The oscillator strengths of structures having benzene rings fused to the 8- and 9-positions, 9- and 10-positions, or 10- and 11-positions of a naphtho[1,2-k]fluoranthene skeleton, a naphtho[2,3-k]fluoranthene skeleton, and a naphtho[1,2-k]fluoranthene skeleton were calculated.

[0032] Based on the density functional theory, quantum chemical calculation at a B3LYP/6-31G* level was used.

[0033] The results are shown in Table 1.

[Table 1]

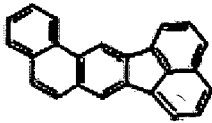
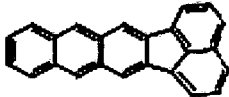
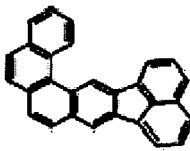
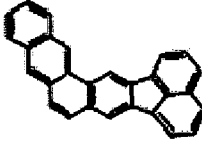
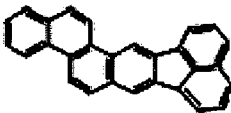
	Structure	Oscillator strength
Naphtho[1,2-k]fluoranthene		0.140
Naphtho[2,3-k]fluoranthene		0.236
Phenanthro[3,4-k]fluoranthene		0.199
Acenaphtho[1,2-b]tetraphene		0.046
Acenaphtho[1,2-b]chrysene		0.252

[0034] The oscillator strength of the acenaphtho[1,2-b]chrysene skeleton of the present invention is the highest among those of the three structures each having a benzene ring fused to the naphtho[1,2-k]fluoranthene skeleton and is higher than that of naphtho[2,3-k]fluoranthene.

[0035] Satisfaction of the requirement 2 means that the skeleton involved in light emission does not have any rotational structure, leading to suppression of a decrease in quantum efficiency due to rotational oscillation.

[0036] The basic skeleton of the acenaphtho[1,2-b]chrysene compound of the present invention does not have any rotational structure, and the quantum efficiency is therefore prevented from being decreased due to rotational oscillation.

[0037] Incidentally, physical properties required in materials suitable for blue light emission as an organic EL display are emission peaks. That is, the blue-light-emitting material is required to have an emission peak of 460 nm or less, in particular, an emission peak of 450 nm or less as a blue-light-emitting material with a high color purity.

[0038] A blue-light-emitting material having an emission peak of 450 nm or less can be provided by appropriately selecting the position of a substituent and the type of the substituent introduced into the acenaphtho[1,2-b]chrysene skeleton of the basic skeleton of the fused polycyclic compound according to the present invention.

[0039] The basic skeleton of the fused polycyclic compound of the present invention has high flatness and easily forms excimers due to intermolecular stacking when it is unsubstituted.

[0040] Accordingly, in order to inhibit the formation of excimers, the fused polycyclic compound of the present invention has a substituent, such as an aryl group, a

heterocyclic group, or an alkyl group, at R₂, R₄, R₈, R₁₂, or R₁₃ in Formula [1].

[0041] The present invention was made through molecular design based on the consideration above.

[0042] The fused polycyclic compound of the present invention has a high color purity and a high quantum efficiency and can therefore be used as a light-emitting material for organic light-emitting devices.

[0043] In particular, the compound can be used as a material that emits blue light.

[0044] In the embodiment, light in a blue region refers to emission of light with a wavelength of 425 nm or more and 460 nm or less.

[0045] Examples of structural formula of the acenaphtho[1,2-b]chrysene compound of the present invention are specifically shown below:

[Chem. 4]

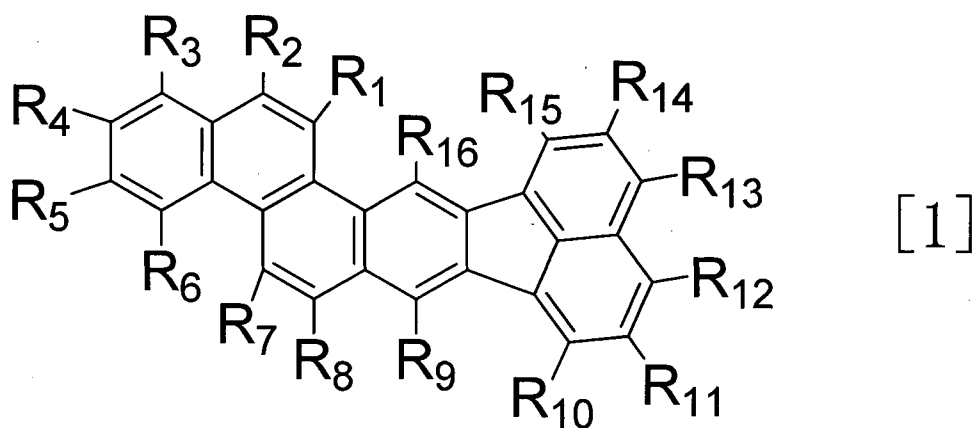

[0046] The following Formulae D1 to D3 show examples of

the compound represented by Formula [1], wherein R_1 to R_{16} are each selected from a hydrogen atom and substituted or unsubstituted alkyl groups.

[Chem. 5]

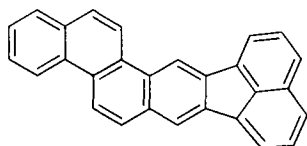

D1

[Chem. 6]

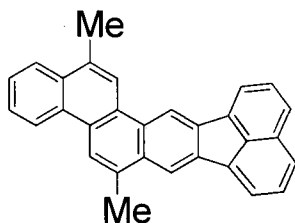

D2

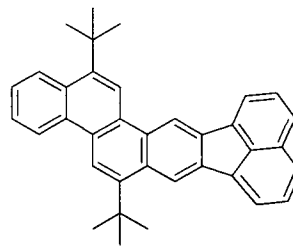

D3

[0047] The following Formulae D4 to D11 show examples of the compound represented by Formula [1], wherein two of R_1 to R_{16} are each an unsubstituted aryl group.

[Chem. 7]

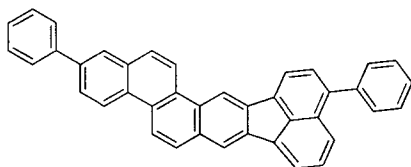

D4

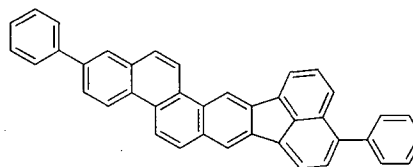

D5

[Chem. 8]

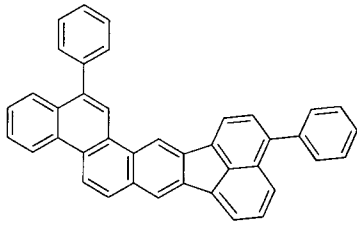

D6

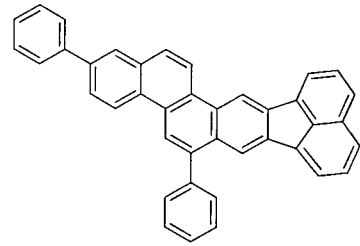

D7

[Chem. 9]

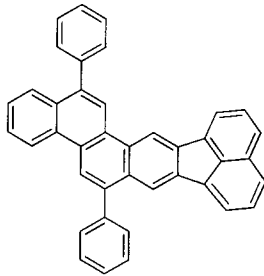

D8

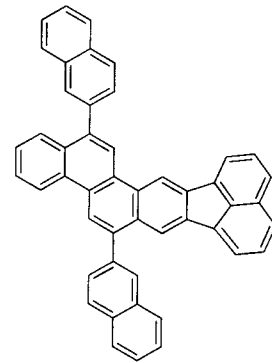

D9

[Chem. 10]

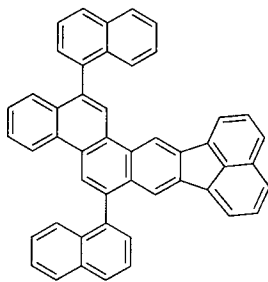

D10

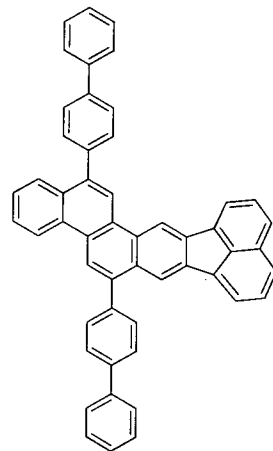

D11

[0048] The acenaphtho[1,2-b]chrysene compound according to the present invention can be a fused polycyclic compound represented by the following Formula [2]:

[Chem. 11]

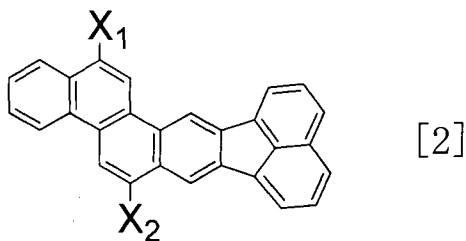

wherein X₁ and X₂ each independently represent a group selected from a substituted aryl groups, and substituted or unsubstituted heterocyclic groups.

[0049] The substituents optionally possessed by the aryl groups, and the heterocyclic groups are the same as those optionally possessed by the substituents in Formula [1].

[0050] The following Formulae D12 to D15 show examples of the compound represented by Formula [2], wherein X₁ and X₂ are each an aryl group substituted with an alkyl group such as a methyl or butyl group.

[Chem. 12]

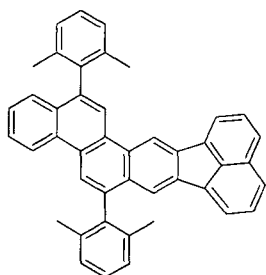
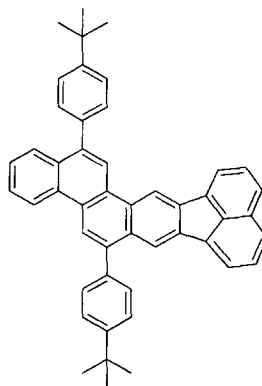
**D12****D13**

[Chem. 13]

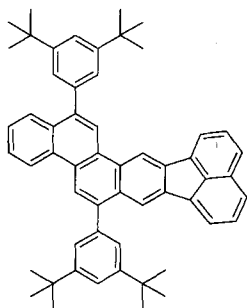
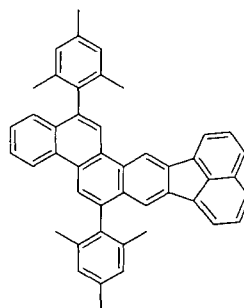
**D14****D15**

[0051] The following Formulae D16 to D21 show examples of the compound represented by Formula [2], wherein X_1 and X_2 are each an aryl group substituted with a cyano group or an alkyl group such as a methyl group.

[Chem. 14]

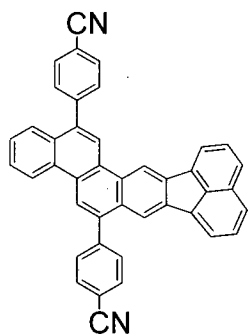
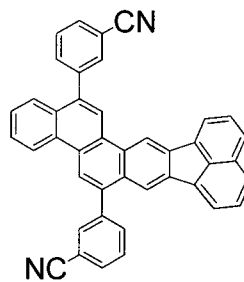
**D16****D17**

[Chem. 15]

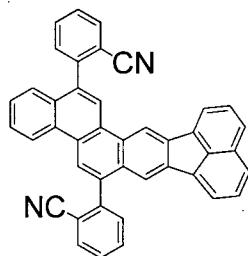
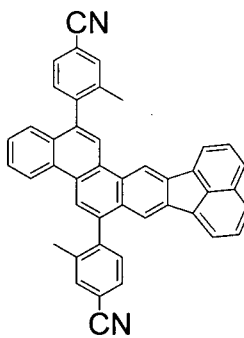
**D18****D19**

[Chem. 16]

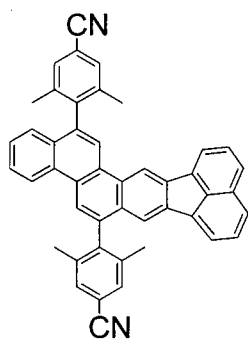
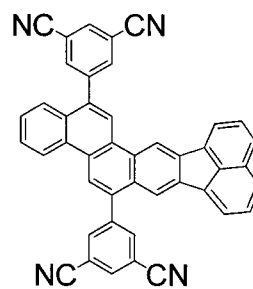
**D20****D21**

[0052] The following Formulae D22 to D29 show examples of the compound represented by Formula [2], wherein X_1 and X_2

are each a substituted or unsubstituted heterocyclic group.

[Chem. 17]

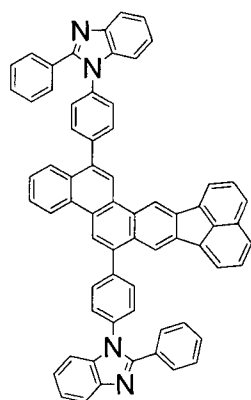

D22

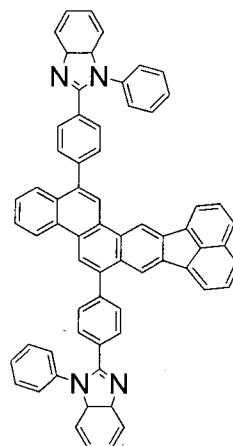

D23

[Chem. 18]

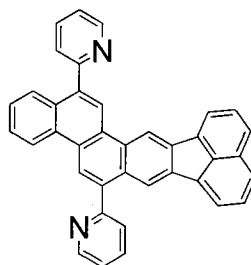

D24

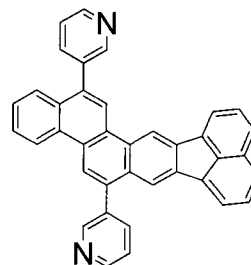

D25

[Chem. 19]

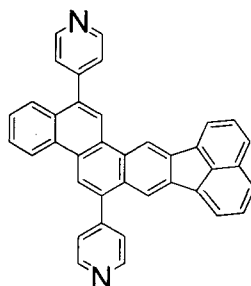

D26

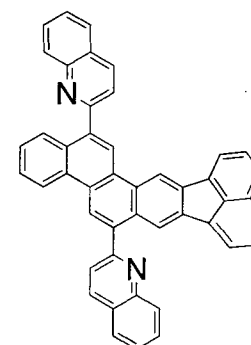

D27

[Chem. 20]

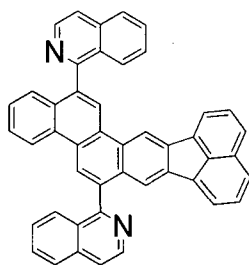

D28

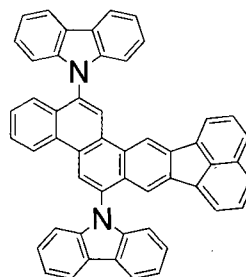

D29

[0053] The fused polycyclic compound of the present invention can be a compound represented by the following Formula [3] or [4]:

[Chem. 21]

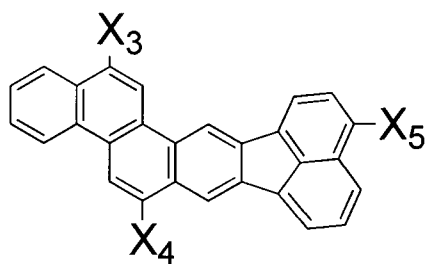

[3]

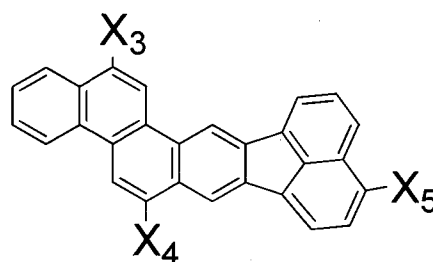

[4]

wherein X_3 to X_5 each independently represent a group selected from substituted or unsubstituted aryl groups, and substituted or unsubstituted heterocyclic groups.

[0054] The substituents optionally possessed by the aryl groups, and the heterocyclic groups are the same as those optionally possessed by the substituents in Formula [1].

[0055] The following Formulae D30 and D31 show examples of the compound represented by Formula [3] or [4], wherein X_3 to X_5 are each an unsubstituted aryl group.

[Chem. 22]

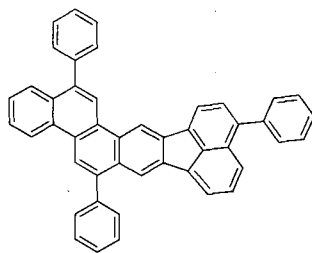
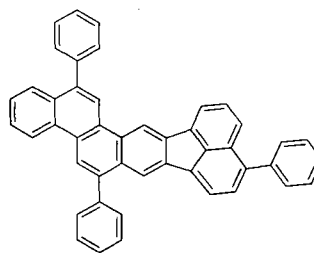
**D30****D31**

[0056] The following Formulae D32 and D33 show examples of the compound represented by Formula [3] or [4], wherein X_3 and X_4 are each an unsubstituted aryl group; and X_5 is a substituted or unsubstituted heterocyclic group.

[Chem. 23]

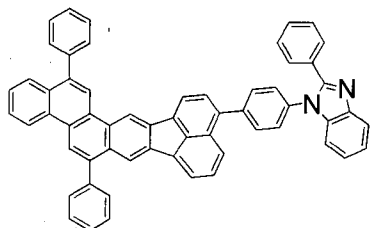
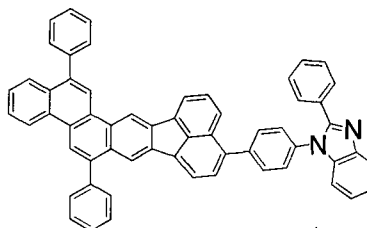
**D32****D33**

[0057] The following Formulae D34 to D51 show examples of the compound represented by Formula [3] or [4], wherein X_3 and X_4 are each an aryl group substituted with a cyano group or a methyl group; and X_5 is an aryl group substituted with a methyl group or an unsubstituted aryl group.

[Chem. 24]

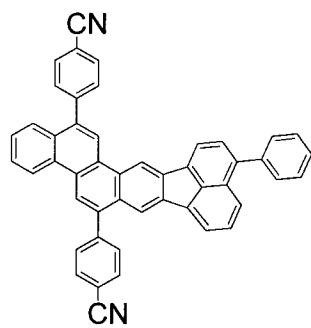

D34

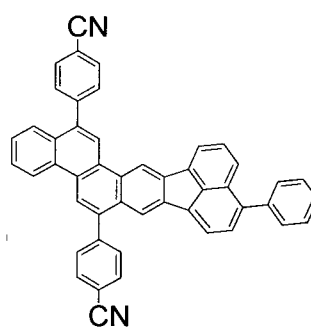

D35

[Chem. 25]

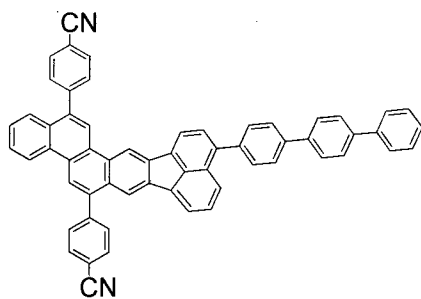

D36

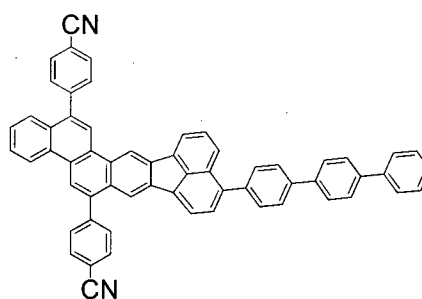

D37

[Chem. 26]

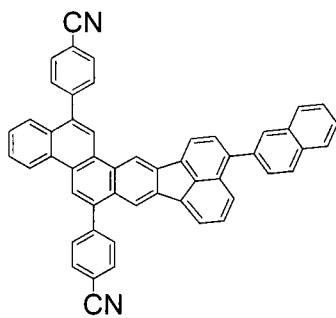

D38

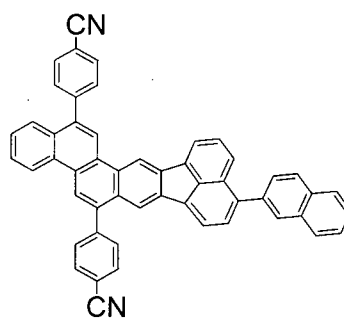

D39

[Chem. 27]

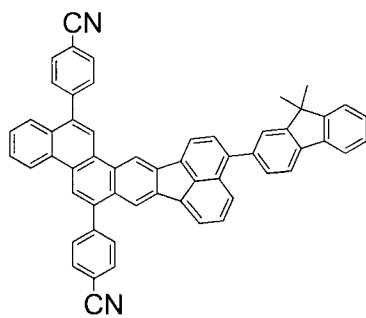

D40

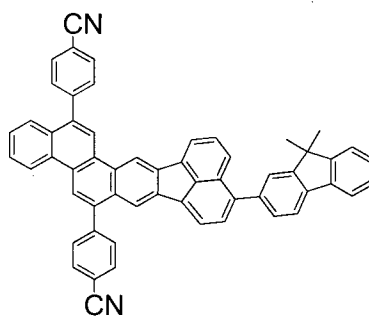

D41

[Chem. 28]

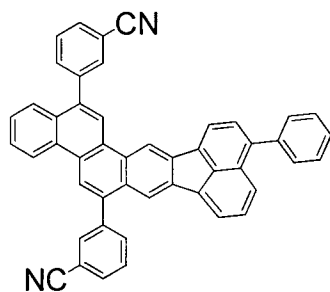

D42

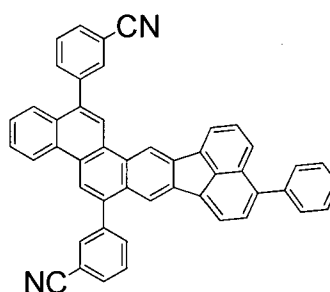

D43

[Chem. 29]

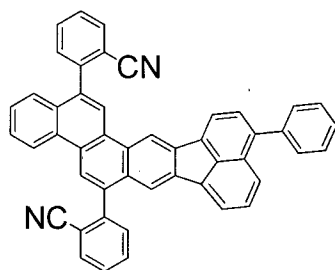

D44

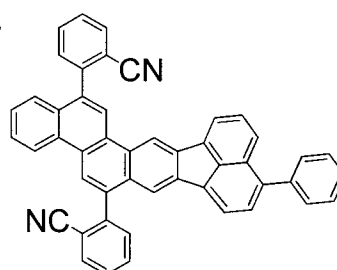

D45

[Chem. 30]

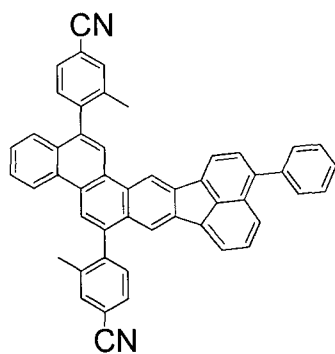

D46

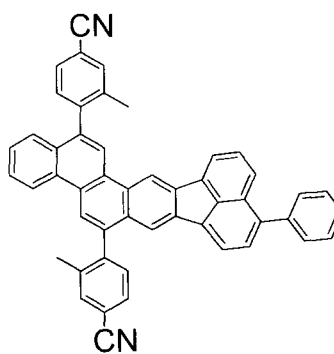

D47

[Chem. 31]

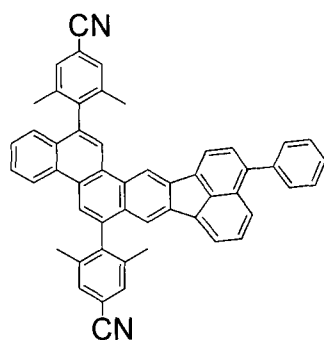

D48

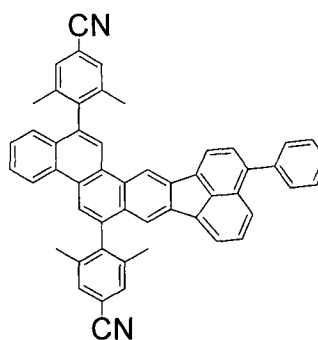

D49

[Chem. 32]

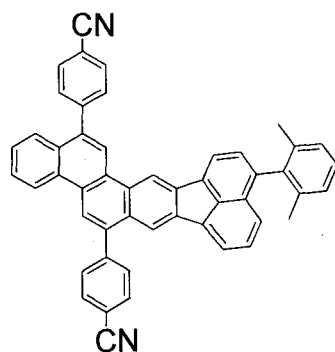

D50

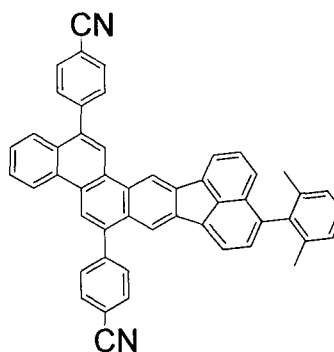

D51

[0058] The following Formulae D52 to D69 show examples of the compound represented by Formula [3] or [4], wherein X₃

to X₅ are each an aryl group substituted with a cyano group or a methyl group.

[Chem. 33]

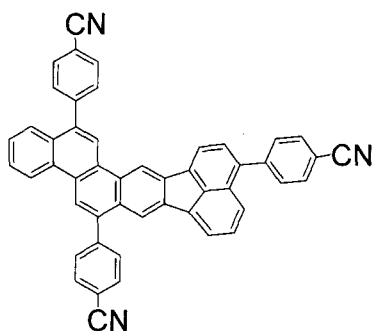

D52

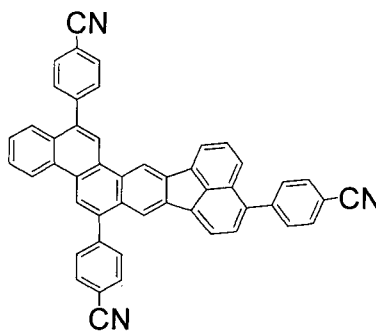

D53

[Chem. 34]

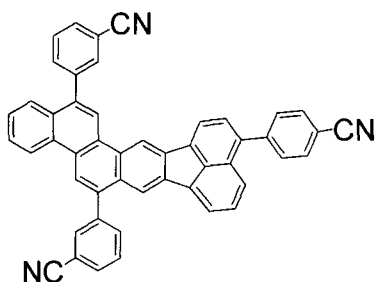

D54

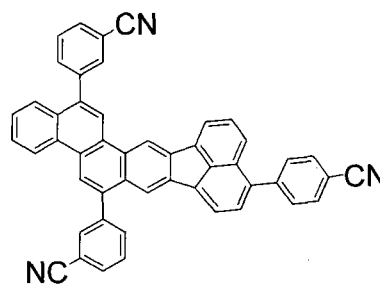

D55

[Chem. 35]

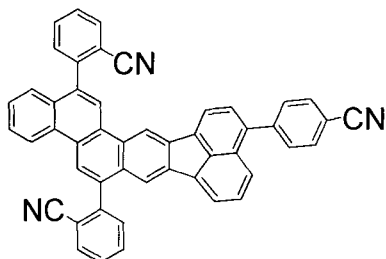

D56

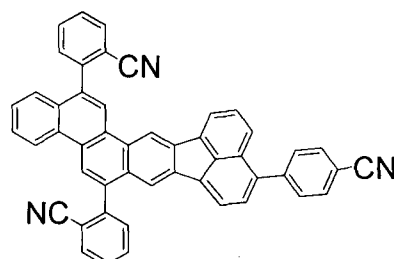

D57

[Chem. 36]

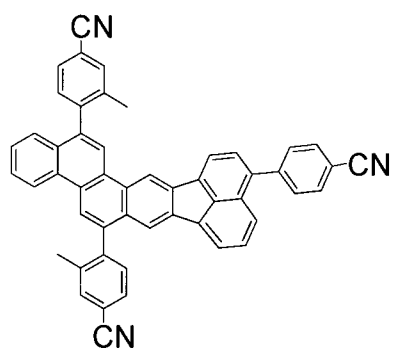
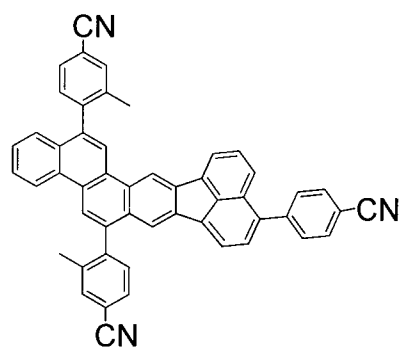
**D58****D59**

[Chem. 37]

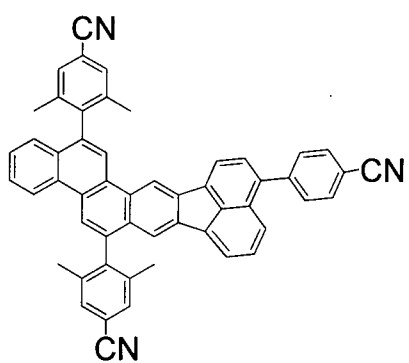
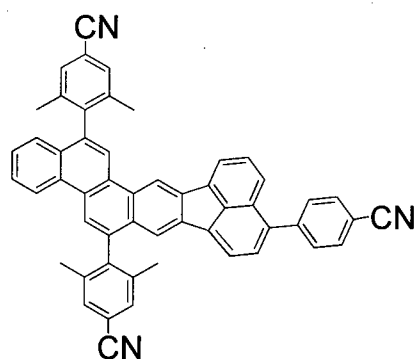
**D60****D61**

[Chem. 38]

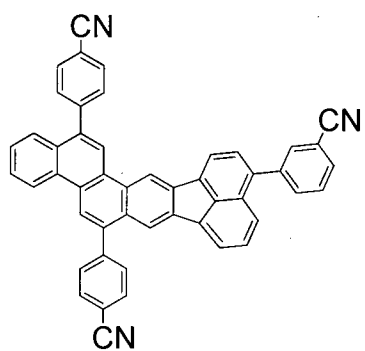
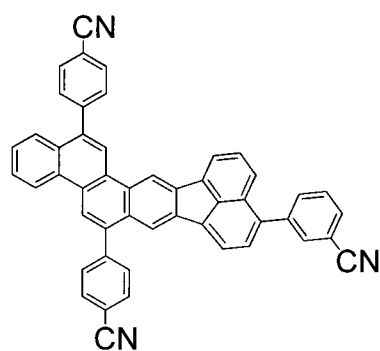
**D62****D63**

[Chem. 39]

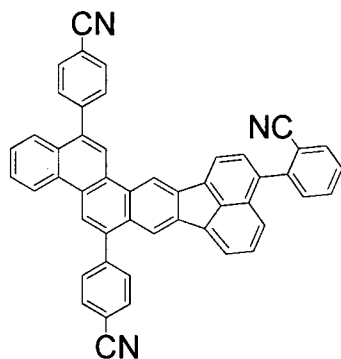

D64

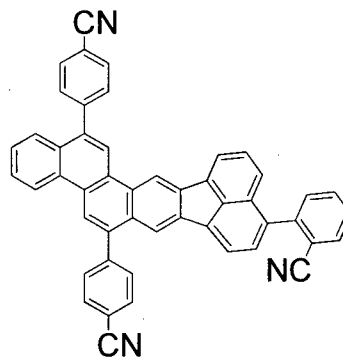

D65

[Chem. 40]

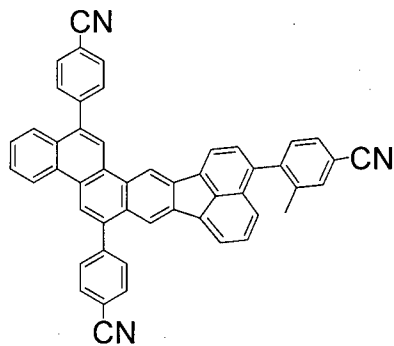

D66

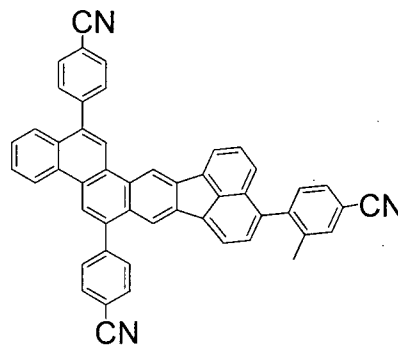

D67

[Chem. 41]

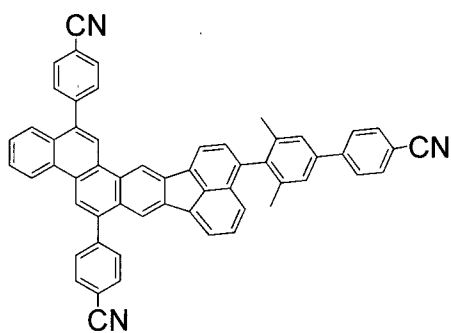

D68

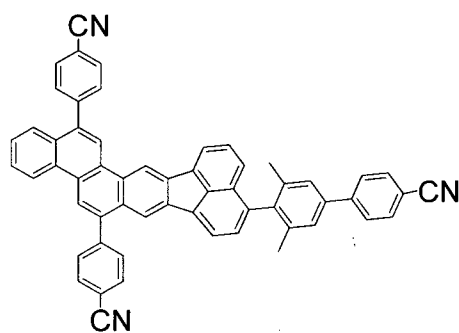

D69

[0059] The following Formulae D70 to D81 show examples of the compound represented by Formula [3] or [4], wherein X_3 and X_4 are each an aryl group substituted with a cyano group or a methyl group; and X_5 is a substituted or unsubstituted heterocyclic group.

[Chem. 42]

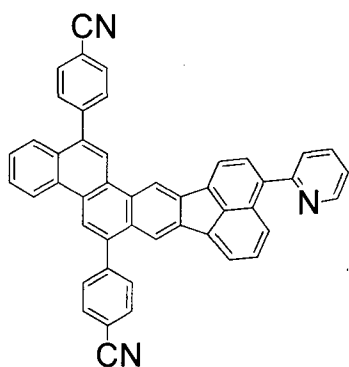

D70

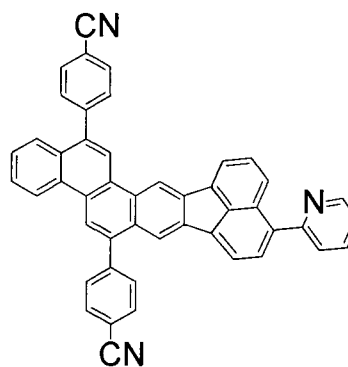

D71

[Chem. 43]

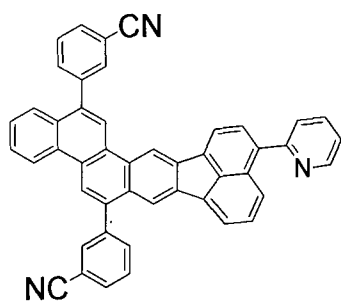

D72

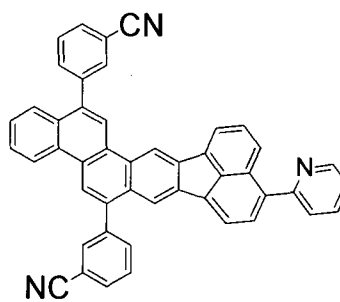

D73

[Chem. 44]

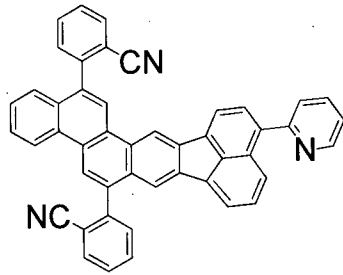

D74

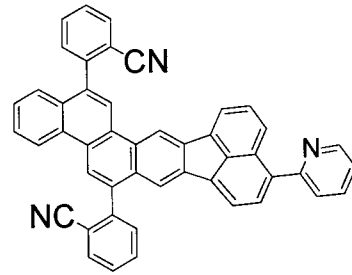

D75

[Chem. 45]

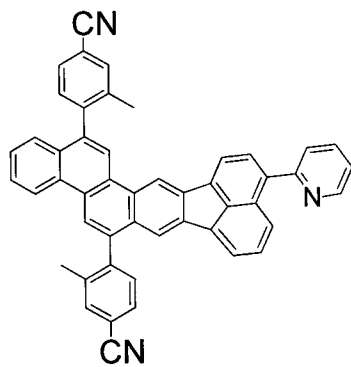

D76

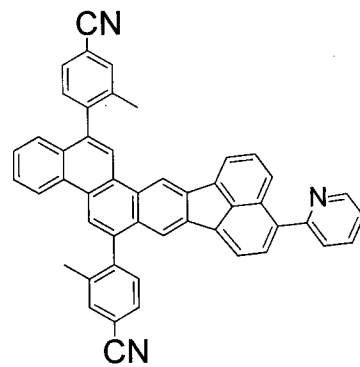

D77

[Chem. 46]

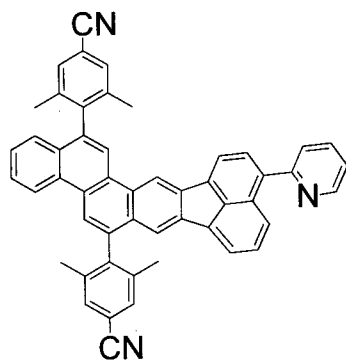

D78

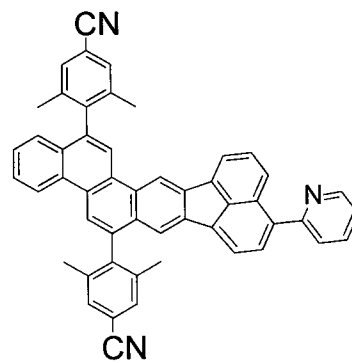

D79

[Chem. 47]

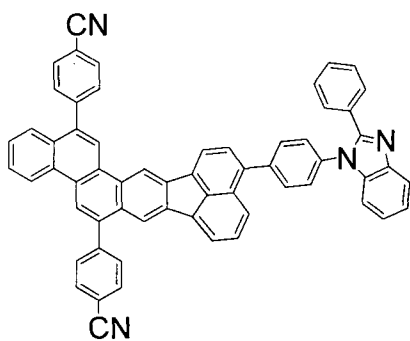

D80

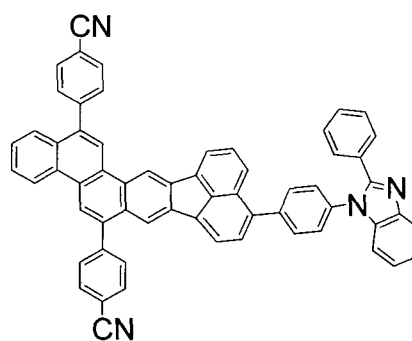

D81

[0060] The fused polycyclic compound of the present invention can be a compound represented by the following Formula [5]:

[Chem. 48]

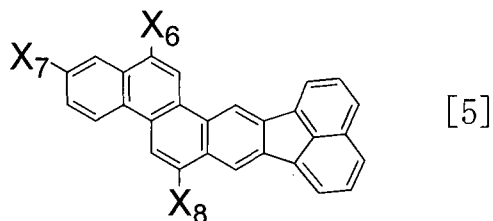

[5]

wherein X_6 to X_8 each independently represent a group selected from a cyano group, substituted or unsubstituted alkyl groups, substituted or unsubstituted aryl groups, and substituted or unsubstituted heterocyclic groups.

[0061] The substituents optionally possessed by the alkyl groups, the aryl groups, and the heterocyclic groups are the same as those optionally possessed by the substituents in Formula [1].

[0062] The following Formulae D82 to D91 show examples of

the compound represented by Formula [5], wherein X_6 and X_8 are each an aryl group substituted with a cyano group or a methyl group; and X_7 is an aryl group substituted with a cyano group or a trifluoromethyl group, an alkyl group, or an cyano group.

[Chem. 49]

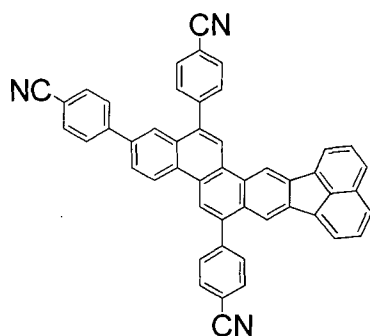

D82

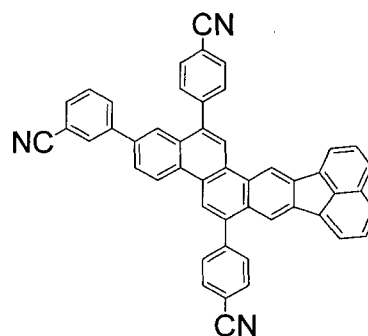

D83

[Chem. 50]

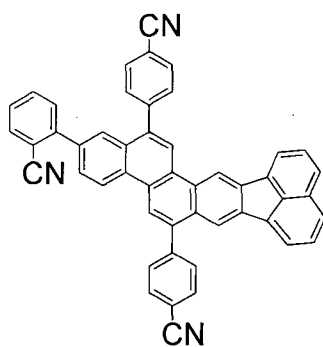

D84

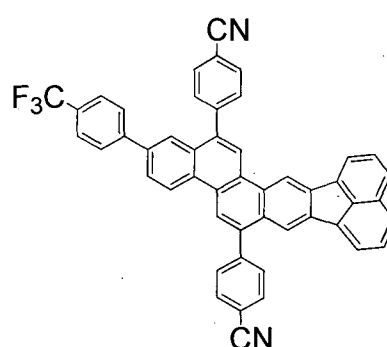

D85

[Chem. 51]

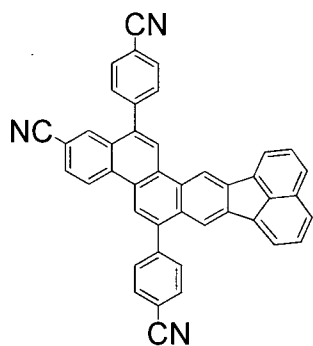

D86

[Chem. 52]

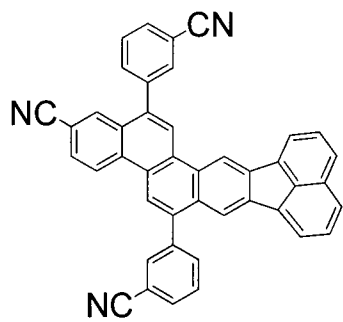

D88

[Chem. 53]

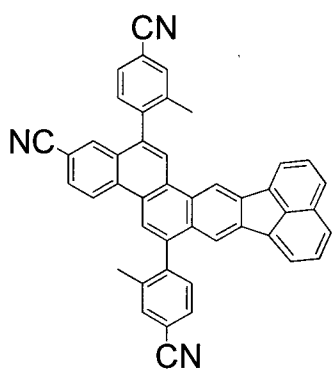

D90

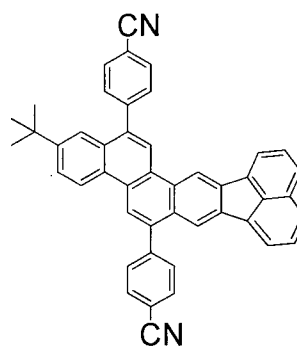

D87

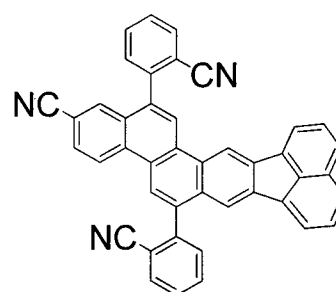

D89

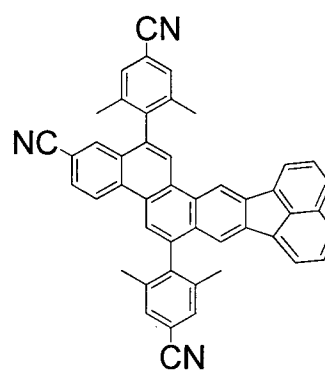

D91

[0063] The following Formulae D92 and D93 show examples of

the compound represented by Formula [5], wherein X_6 and X_8 are each a heterocyclic group; and X_7 is a cyano group.

[Chem. 54]

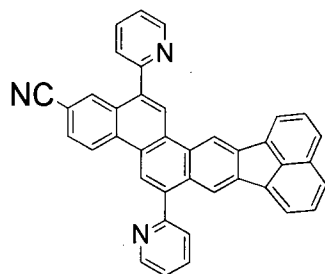

D92

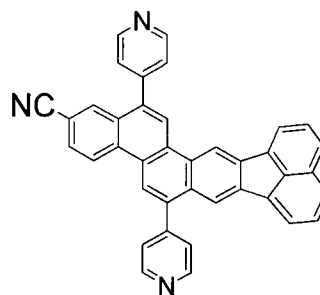

D93

[0064] The fused polycyclic compound of the present invention can be a compound represented by the following Formula [6] or [7]:

[Chem. 55]

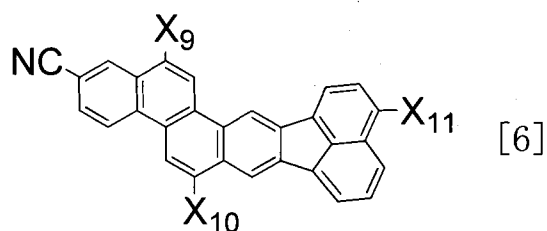

[6]

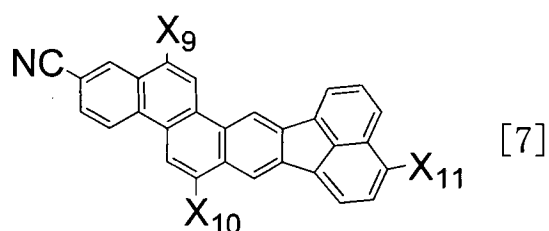

[7]

wherein X_9 to X_{11} each independently represent a group selected from a cyano group, substituted or unsubstituted aryl groups, and substituted or unsubstituted heterocyclic groups.

[0065] The substituents optionally possessed by the alkyl groups, the aryl groups, and the heterocyclic groups are the same as those optionally possessed by the substituents in

Formula [1].

[0066] The following Formulae D94 and D95 show examples of the compound represented by Formula [6] or [7], wherein X_9 and X_{10} are each an aryl group substituted with a cyano group or a methyl group; and X_{11} is a cyano group.

[Chem. 56]

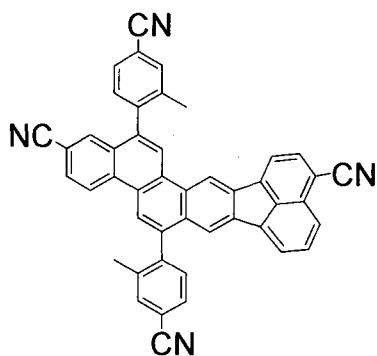

D94

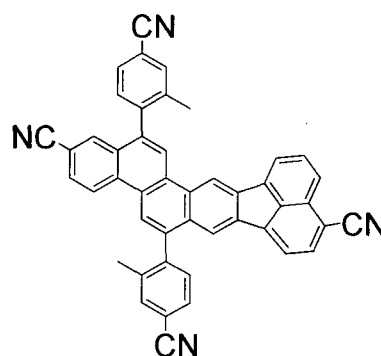

D95

[0067] The following Formulae D96 to D103 show examples of the compound represented by Formula [6] or [7], wherein X_9 and X_{10} are each an aryl group substituted with a cyano group or a methyl group; and X_{11} is an unsubstituted aryl group or an aryl group substituted with an alkyl group.

[Chem. 57]

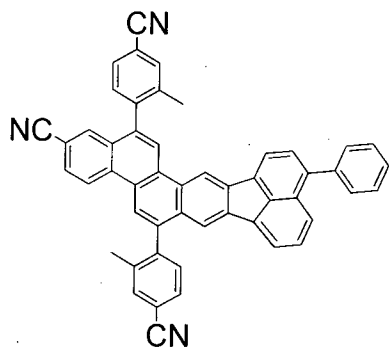

D96

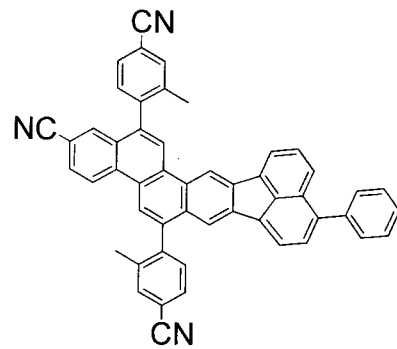

D97

[Chem. 58]

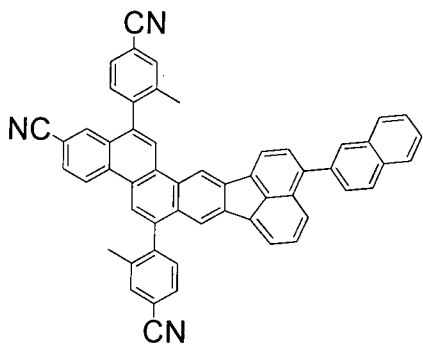

D98

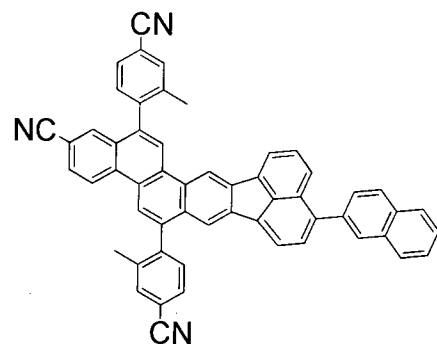

D99

[Chem. 59]

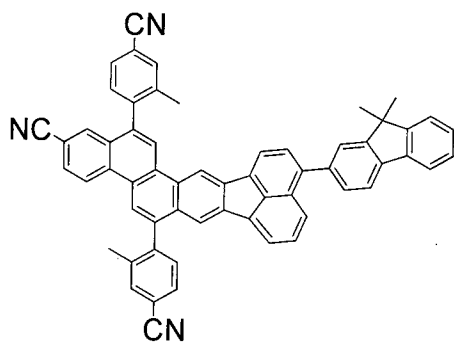

D100

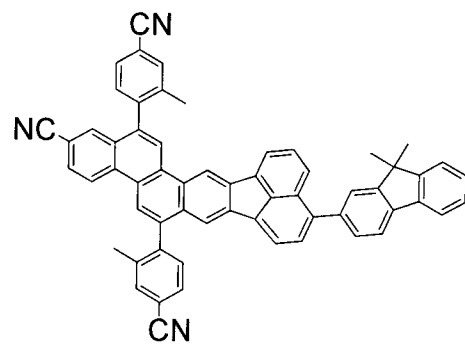

D101

[Chem. 60]

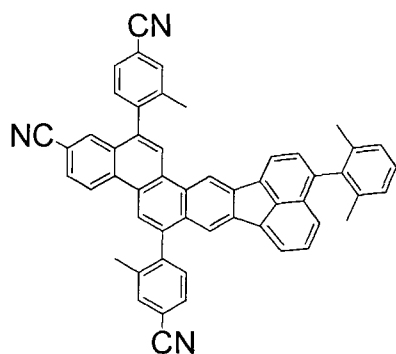
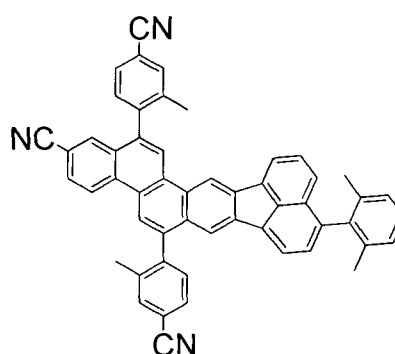
**D102****D103**

[0068] The following Formulae D104 to D115 show examples of the compound represented by Formula [6] or [7], wherein X_9 to X_{11} are each an aryl group substituted with a cyano group, a methyl group, or a trifluoromethyl methyl group.

[Chem. 61]

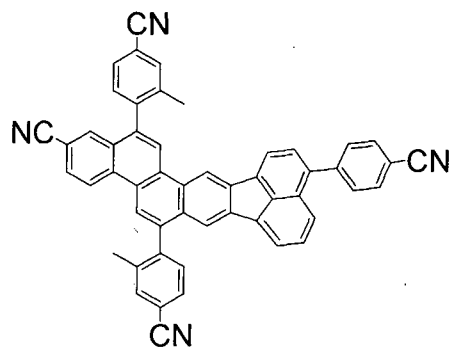
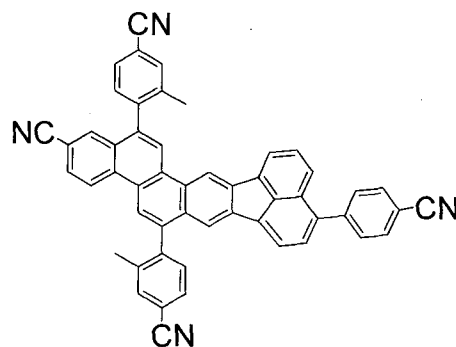
**D104****D105**

[Chem. 62]

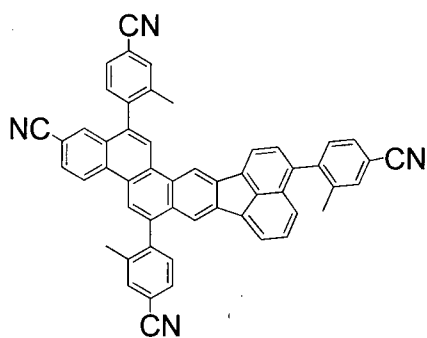

D 106

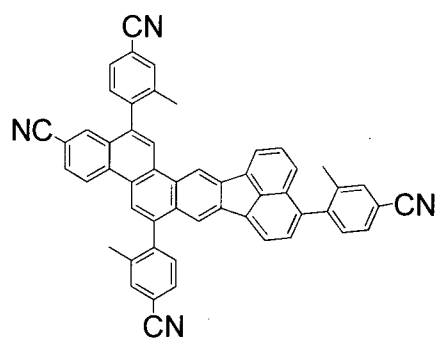

D 107

[Chem. 63]

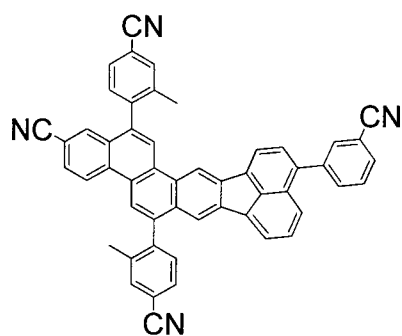

D 108

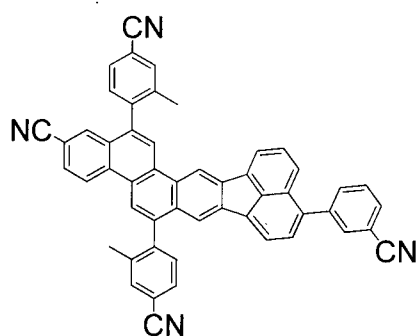

D 109

[Chem. 64]

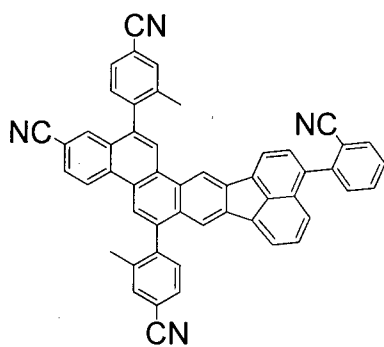

D 110

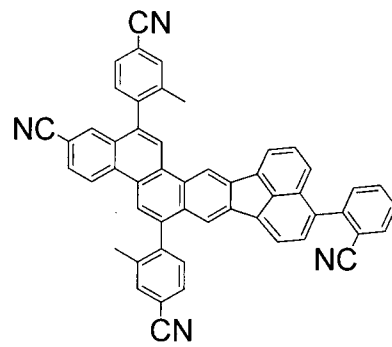

D 111

[Chem. 65]

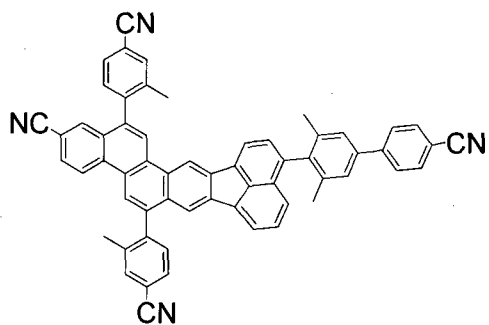

D112

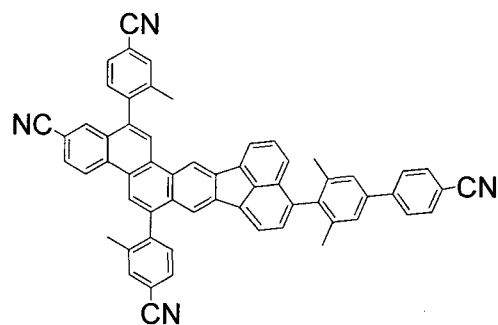

D113

[Chem. 66]

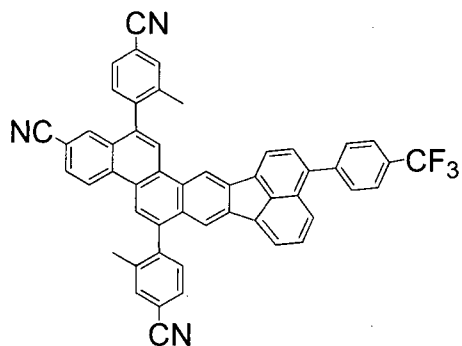

D114

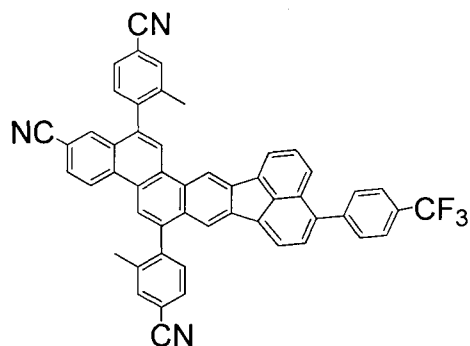

D115

[0069] The following Formulae D116 and D117 show examples of the compound represented by Formula [6] or [7], wherein X_9 and X_{10} are each an aryl group substituted with a cyano group or a methyl group; and X_{11} is a substituted or unsubstituted heterocyclic group.

[Chem. 67]

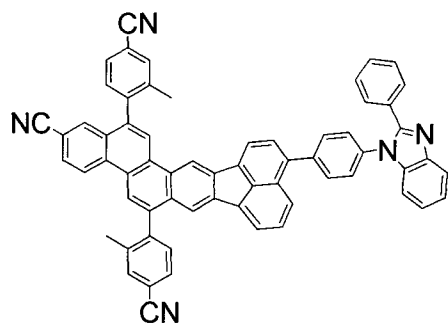

D116

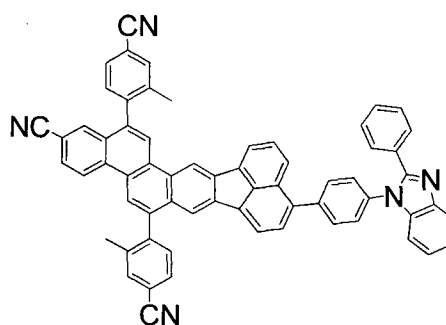

D117

[0070] The following Formulae D118 to D121 show examples of the compound represented by Formula [6] or [7], wherein X_9 and X_{10} are each an unsubstituted aryl group or an aryl group substituted with an alkyl group; and X_{11} is an aryl group substituted with a cyano group.

[Chem. 68]

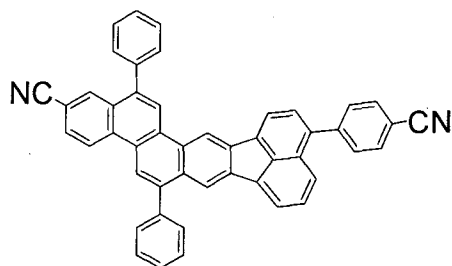

D118

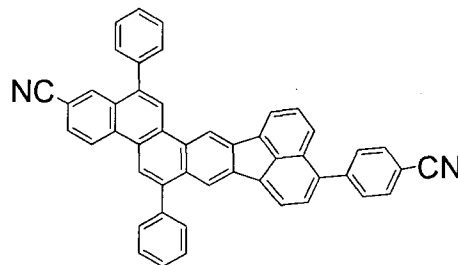

D119

[Chem. 69]

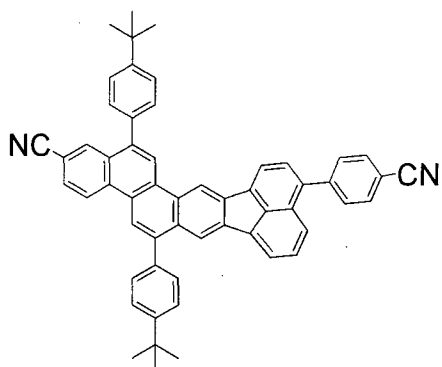

D120

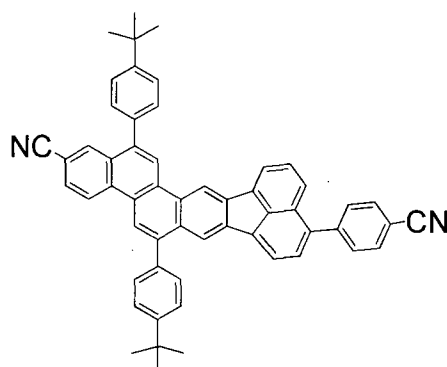

D121

[0071] The fused polycyclic compound of the present invention can be a compound represented by the following Formula [8] or [9]:

[Chem. 70]

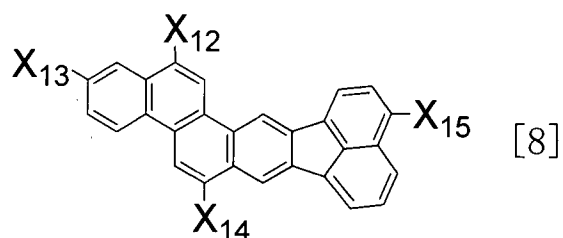

[8]

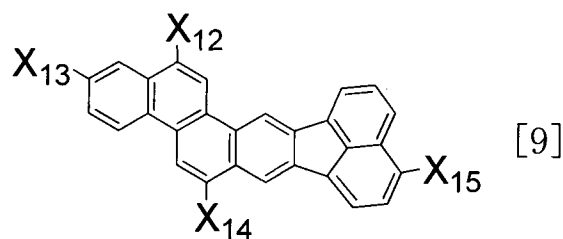

[9]

wherein X_{12} to X_{15} each independently represent a group selected from substituted or unsubstituted alkyl groups, substituted or unsubstituted aryl groups, and substituted or unsubstituted heterocyclic groups.

[0072] The substituents optionally possessed by the alkyl groups, the aryl groups, and the heterocyclic groups are the same as those optionally possessed by the substituents in Formula [1].

[0073] The following Formulae D122 to D125 show examples of the compound represented by Formula [8] or [9], wherein

X₁₂ to X₁₄ are each an unsubstituted aryl group; and X₁₅ is an alkyl group.

[Chem. 71]

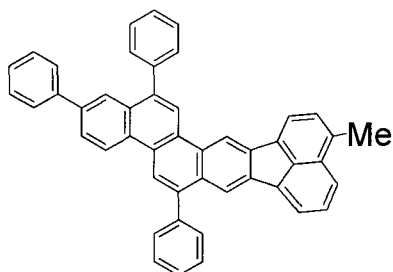

D 122

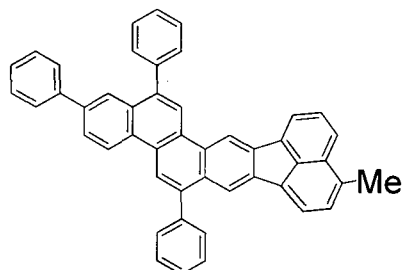

D 123

[Chem. 72]

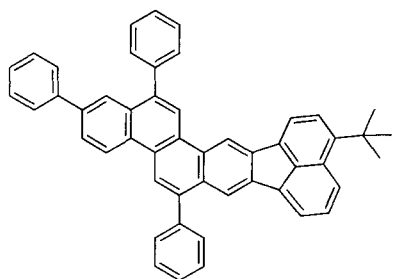

D 124

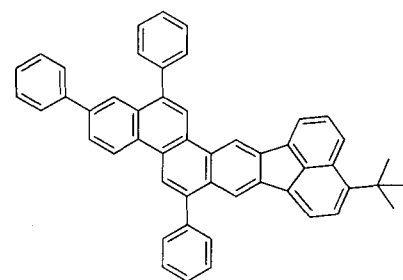

D 125

[0074] The following Formulae D126 to D129 show examples of the compound represented by Formula [8] or [9], wherein X₁₂ to X₁₄ are each an unsubstituted aryl group or an aryl group substituted with a cyano group; and X₁₅ is a substituted or unsubstituted heterocyclic group.

[Chem. 73]

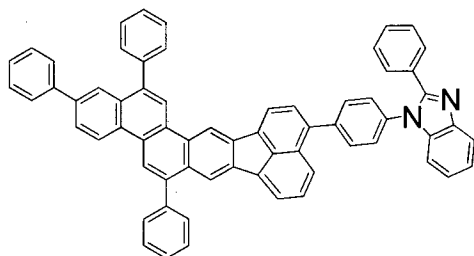

D126

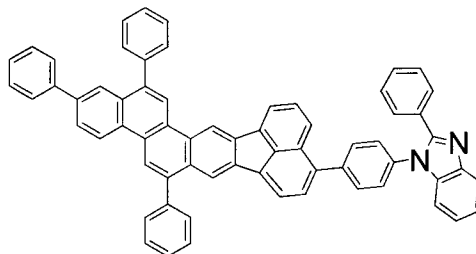

D127

[Chem. 74]

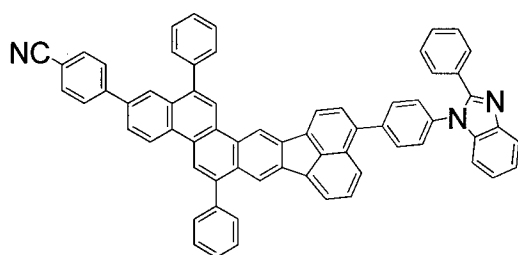

D128

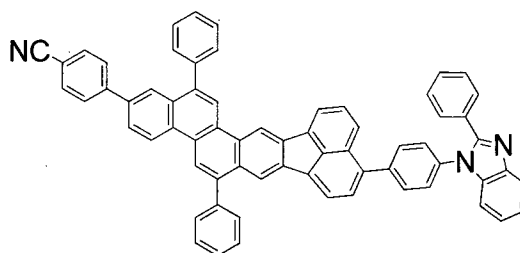

D129

[0075] The following Formulae D130 and D131 show examples of the compound represented by Formula [8] or [9], wherein X_{12} and X_{14} are each an aryl group substituted with a cyano group or a methyl group; and X_{13} and X_{15} are each an unsubstituted aryl group or an unsubstituted heterocyclic group.

[Chem. 75]

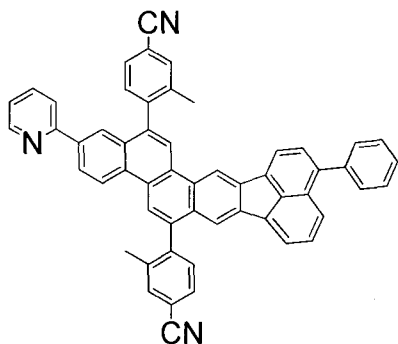

D130

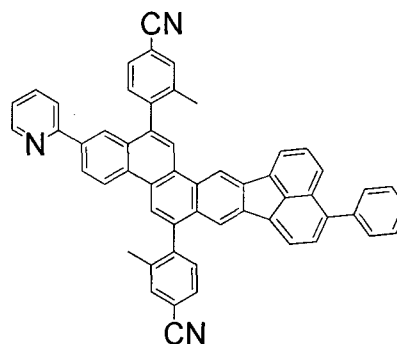

D131

Description of synthetic route

[0076] The fused polycyclic compound represented by Formula [1] can be synthesized as in synthetic routes 1 to 3 shown below.

[0077] In synthesis through synthetic route 1 and synthetic route 3, isomers are produced due to the substituent Y_2 or Y_6 . The isomers do not substantially differ in the luminescence properties as long as that two Y_2 s (or Y_6 s) are the same and therefore may be used after isolation by, for example, recrystallization or may be directly used as a mixture.

[0078] Since the luminescence properties of the mixture are not low compared to those of a single isomer, the mixture ratio is not specifically limited. In addition, the mixture can suppress crystallization and, thereby, can be expected to show an effect of inhibiting concentration quenching.

[0079] Synthetic route 1

[Chem. 76]

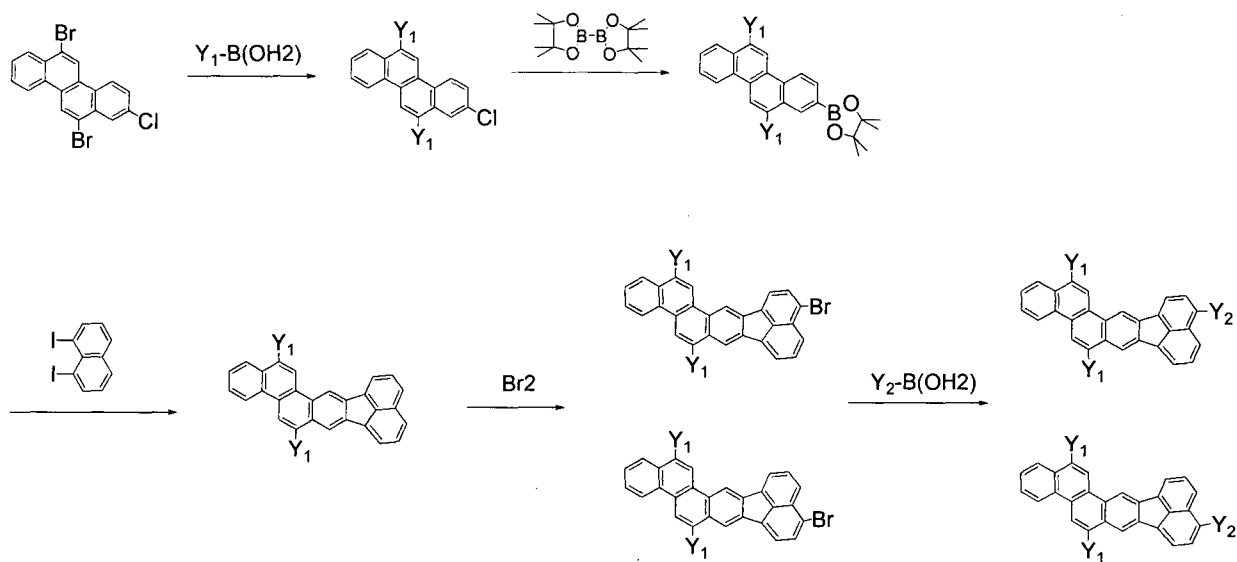

[0080] Synthetic route 2

[Chem. 77]

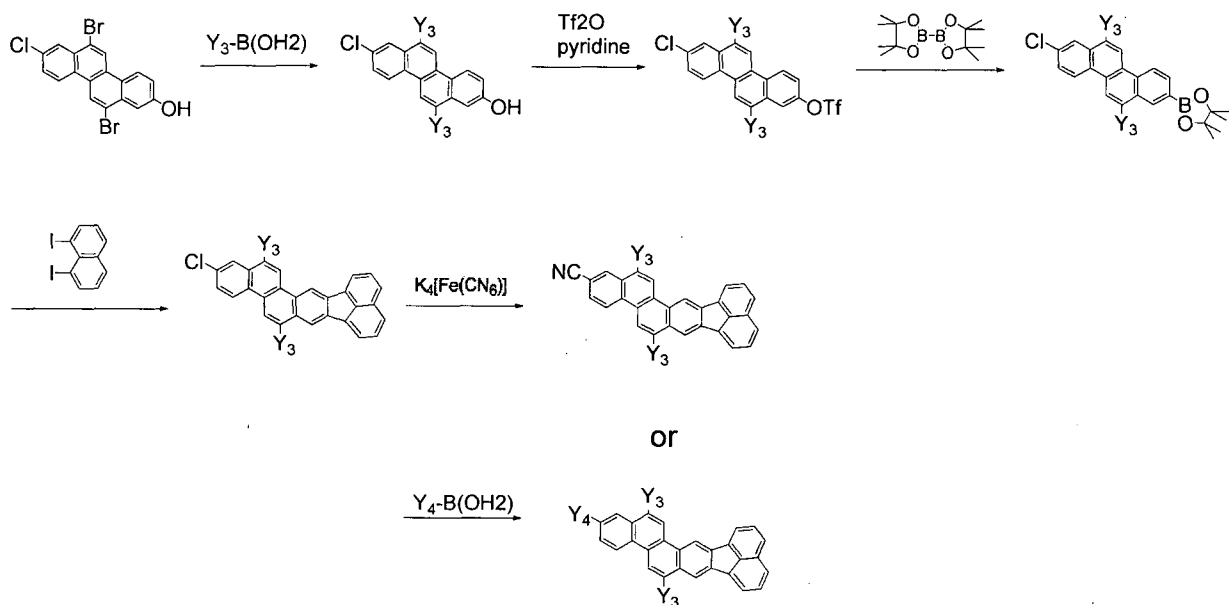





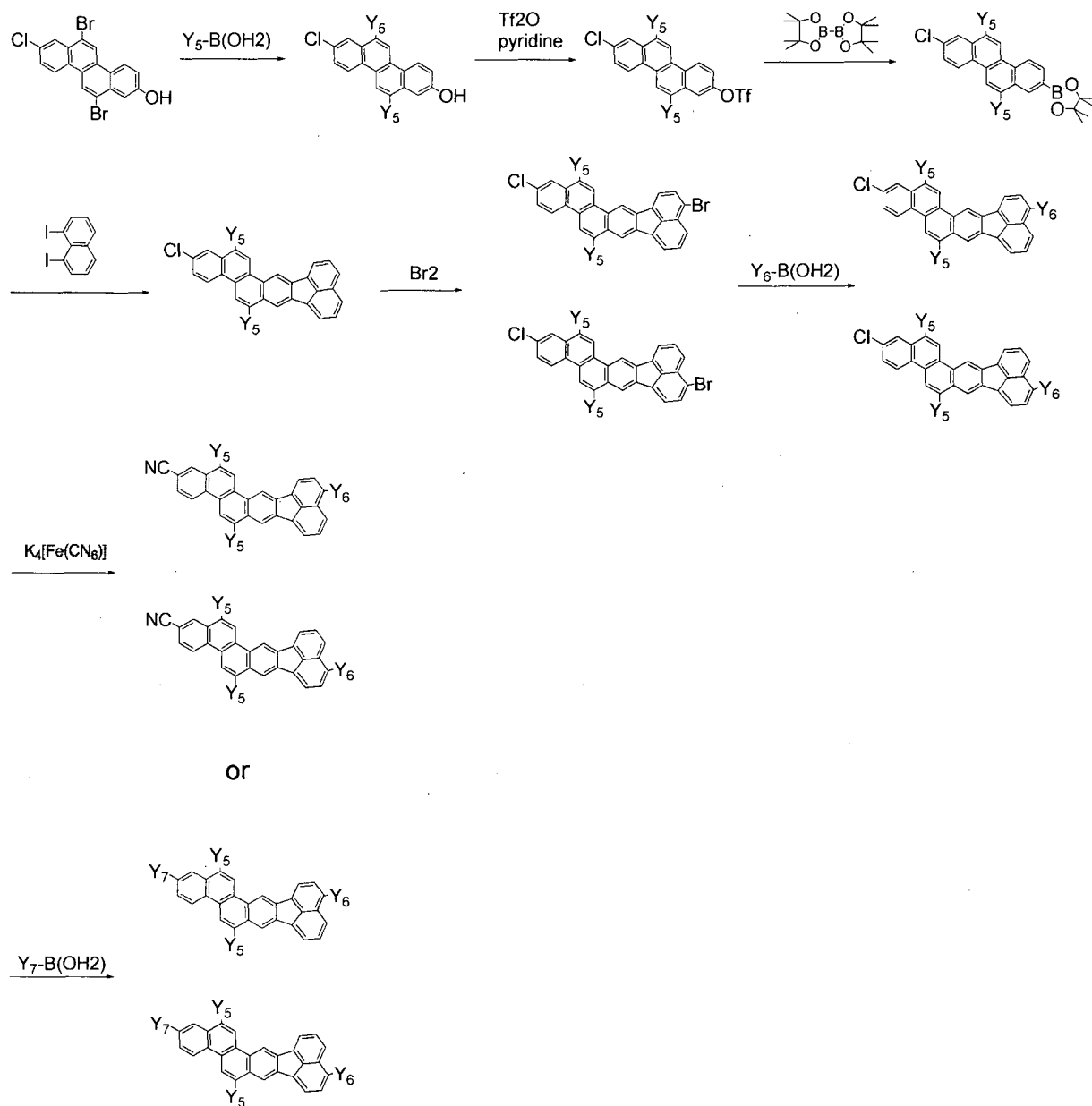

[0081] Synthetic route 3

[Chem. 78]

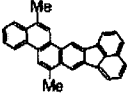

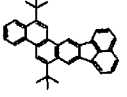

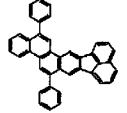
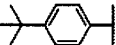
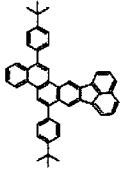
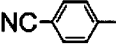
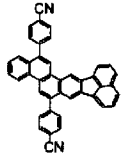
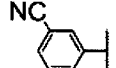
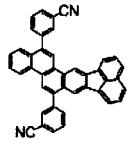
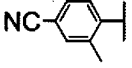
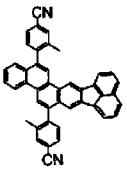

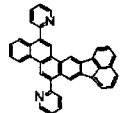
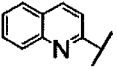
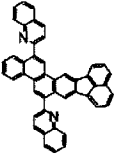



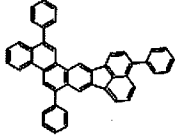
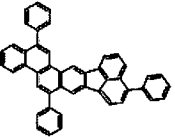
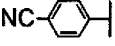
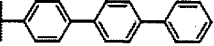
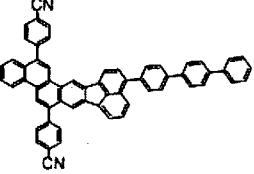
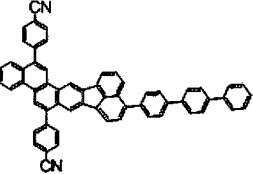
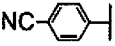
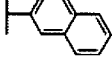
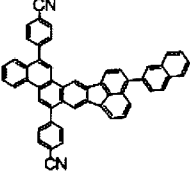
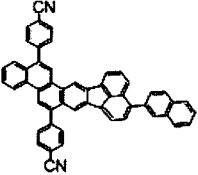
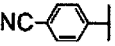
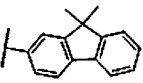
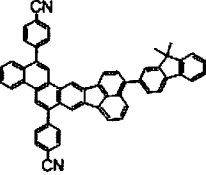
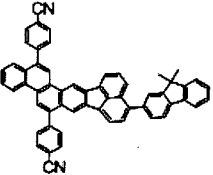
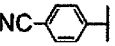

[0082] Examples of the organic compound prepared by synthetic route 1 are shown below. Table 2 shows organic compounds having two substituents, and Table 3 shows organic compounds having three substituents.

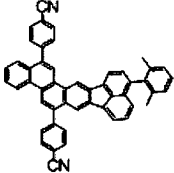
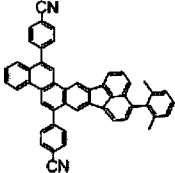
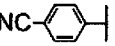
[Table 2]

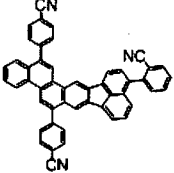
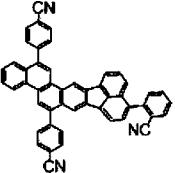
	Y1	Y2	Synthetic example
Synthetic compound 1		/	
Synthetic compound 2			
Synthetic compound 3			
Synthetic compound 4			
Synthetic compound 5			
Synthetic compound 6			
Synthetic compound 7			
Synthetic compound 8			
Synthetic compound 9			

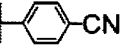
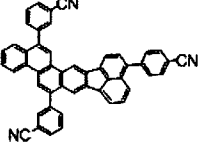
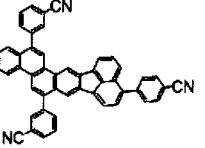

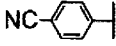
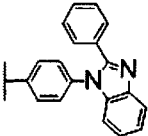
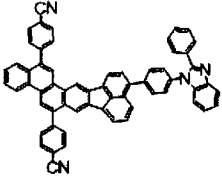
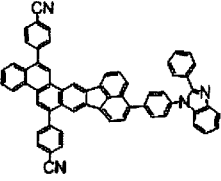
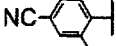

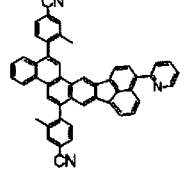
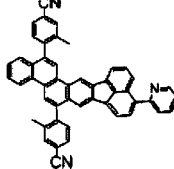

[Table 3]

	Y1	Y2	Synthetic example	
Synthetic compound 10				
Synthetic compound 11				
Synthetic compound 12				
Synthetic compound 13				
Synthetic compound 14				
Synthetic compound 15				
Synthetic compound 16				

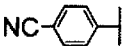
Synthetic compound 17				
Synthetic compound 18				

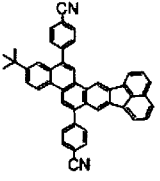
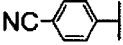
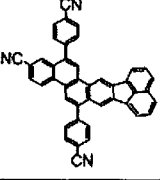
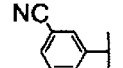
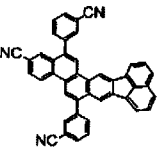
[0083] Examples of the organic compound prepared by synthetic route 2 are shown in Table 4.

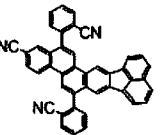
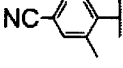
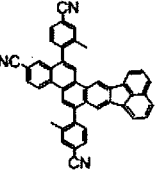
[Table 4]

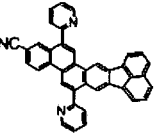
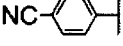
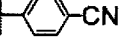
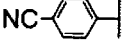
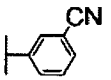
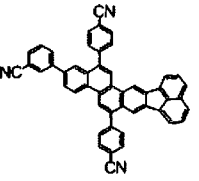

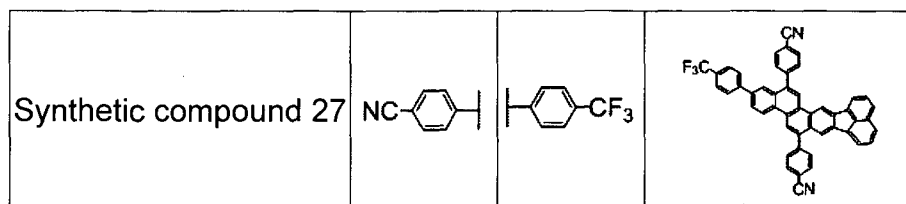
	Y3	Y4	Synthetic example
Synthetic compound 19			
Synthetic compound 20		/	
Synthetic compound 21			
Synthetic compound 22			
Synthetic compound 23			
Synthetic compound 24		/	
Synthetic compound 25			
Synthetic compound 26			



[0084] Examples of the organic compound prepared by synthetic route 3 are shown in Table 5.

[Table 5]

	Y5	Y6	Y7	Synthetic example	
Synthetic compound 28					
Synthetic compound 29					
Synthetic compound 30					
Synthetic compound 31					
Synthetic compound 32					
Synthetic compound 33					
Synthetic compound 34					
Synthetic compound 35					

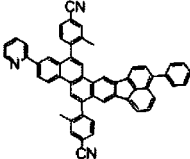
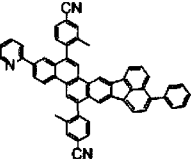
Synthetic compound 36					
-----------------------	---	---	---	--	---

Description of organic light-emitting device in the embodiment

[0085] An organic light-emitting device according to the embodiment will be described.

[0086] The organic light-emitting device according to the embodiment includes a pair of electrodes, i.e., an anode and a cathode, and an organic compound layer disposed between the electrodes. The organic compound layer is an element including the organic compound represented by Formula [1].

[0087] The organic compound layer of the organic light-emitting device according to the embodiment may have a monolayer structure or a multi-layer structure.

[0088] Here, the multi-layer is a layer appropriately selected from the group consisting of hole-injecting layers, hole-transporting layers, light-emitting layers, hole-blocking layers, electron-transporting layers, electron-injecting layers, and exciton-blocking layers and may be a combination of layers selected from the group.

[0089] The configuration of the organic light-emitting device according to the embodiment is not limited thereto, and various layer configurations can be employed. For

example, an insulating layer may be disposed at the interface between an electrode and an organic compound layer; an adhesive layer or an interference layer may be provided; or an electron-transporting layer or a hole-transporting layer may be composed of two layers having different ionization potentials.

[0090] The configuration of the device may be a top emission system, which extracts light from the electrode on the substrate side, or a bottom emission system, which extracts light from the opposite side of the substrate. Alternatively, a configuration in which light is extracted from both sides can also be employed.

[0091] In the organic light-emitting device according to the embodiment, the light-emitting layer can contain the organic compound of the present invention.

[0092] The concentration of the host material in the light-emitting layer of the organic light-emitting device according to the embodiment is 50 wt% or more and 99.9 wt% or less, in particular, 80 wt% or more and 99.5 wt% or less, based on the total amount of the light-emitting layer.

[0093] The concentration of the guest material in the light-emitting layer of the organic light-emitting device according to the embodiment is 0.1 wt% or more and 30 wt% or less, in particular, 0.5 wt% or more and 10 wt% or less, based on the amount of the host material. The light-

emitting layer may have a monolayer structure or a multi-layer structure.

[0094] A plurality of the light-emitting layers may be stacked or may be horizontally arranged. In the horizontal arrangement, every light-emitting layer is in contact with the adjacent layers such as a hole-transporting layer and an electron-transporting layer.

[0095] The light-emitting layer may have a configuration where a single light-emitting layer contains light-emitting materials emitting light of different colors. In such a case, the light-emitting materials may form the respective domains.

[0096] The organic light-emitting device according to the embodiment may emit white light by containing different light-emitting materials in the light-emitting layer.

[0097] In the embodiment, the host material is a compound having a largest weight ratio among the compounds constituting the light-emitting layer, and the guest material is a compound having a smaller weight ratio than that of the host material among the compounds constituting the light-emitting layer and bearing main light emission. The guest material is also called a dopant.

[0098] The assist material is a compound having a smaller weight ratio than that of the host material among the compounds constituting the light-emitting layer and

assisting the light emission of the guest material. The assist material is also called a second host material.

[0099] In the organic light-emitting device according to the embodiment, in addition to the compound according to the present invention, for example, a known hole-injecting material, hole-transporting material, host material, guest material, electron-injecting material, or electron-transporting material can be optionally used. These materials may be a low-molecular compound or a high-molecular compound.

[0100] Examples of these compounds are shown below.

[0101] As the hole-injecting or transporting material, a material having high hole mobility can be used. Examples of the low- or high-molecular material having hole-injecting or transporting ability include, but not limited to, triarylamine derivatives, phenylenediamine derivatives, stilbene derivatives, phthalocyanine derivatives, porphyrin derivatives, poly(vinylcarbazole), poly(thiophene), and other electrically conductive polymers.

[0102] Examples of the host material include, but not limited to, triarylamine derivatives, phenylene derivatives, fused ring aromatic compounds (e.g., naphthalene derivatives, phenanthrene derivatives, fluorene derivatives, and chrysene derivatives), organic metal complexes (e.g., organic aluminum complexes such as tris(8-quinolinolate)aluminum,

organic beryllium complexes, organic iridium complexes, and organic platinum complexes), and polymer derivatives such as poly(phenylenevinylene) derivatives, poly(fluorene) derivatives, poly(phenylene) derivatives, poly(thienylenevinylene) derivatives, and poly(acetylene) derivatives.

[0103] The electron-injecting or transporting material is appropriately selected by considering the balance with the hole mobility of the hole-injecting or transporting material.

[0104] Examples of the material having electron-injecting or transporting ability include, but not limited to, oxadiazole derivatives, oxazole derivatives, pyrazine derivatives, triazole derivatives, triazine derivatives, quinoline derivatives, quinoxaline derivatives, phenanthroline derivatives, and organic aluminum complexes.

[0105] As the anode material, a material having a higher work function is used. Examples of the material include simple metals such as gold, platinum, silver, copper, nickel, palladium, cobalt, selenium, vanadium, and tungsten; alloys of these simple metals; and metal oxides such as tin oxide, zinc oxide, indium oxide, indium tin oxide (ITO), and indium zinc oxide. In addition, electrically conductive polymers such as polyaniline, polypyrrole, and polythiophene can be used.

[0106] These electrode materials may be used alone or in

combination. The anode may have a monolayer structure or a multi-layer structure.

[0107] In contrast, as the cathode material, a material having a lower work function is used. Examples of the material include alkali metals such as lithium; alkaline earth metals such as calcium; simple metals such as aluminum, titanium, manganese, silver, lead, and chromium; and alloys of these simple metals, such as magnesium-silver, aluminum-lithium, and aluminum-magnesium. In addition, metal oxides such as indium tin oxide (ITO) can be used. These electrode materials may be used alone or in combination. The cathode may have a monolayer structure or a multi-layer structure.

[0108] In the organic light-emitting device according to the embodiment, a layer containing the organic compound according to the embodiment and layers of other organic compounds are formed by the following methods.

[0109] For example, a layer is formed by vacuum vapor deposition, ionized vapor deposition, sputtering, plasma coating, or known coating such as spin coating, dipping, a casting method, an LB method, or an ink-jetting method of a compound dissolved in an appropriate solvent.

[0110] In the case of forming a layer by vacuum deposition or solution coating, crystallization hardly occurs, and the resulting layer shows excellent stability for a long time. In addition, in coating, a film can be formed in combination

with an appropriate binder resin.

[0111] Examples of the binder resin include, but not limited to, polyvinyl carbazole resins, polycarbonate resins, polyester resins, ABS resins, acrylic resins, polyimide resins, phenol resins, epoxy resins, silicone resins, and urea resins.

[0112] These binder resins may be used alone as a homopolymer or a copolymer or in combination of two or more thereof. In addition, known additives such as a plasticizer, an antioxidant, and a UV absorber may be optionally used together with the binder resin.

Use of organic light-emitting device according to the embodiment

[0113] The organic light-emitting device according to the embodiment can be used as a component of a display apparatus or a lighting system. Other examples of the use include exposure light sources of electrophotographic image forming apparatuses, backlights of liquid crystal display apparatuses, and light sources. The organic light-emitting device may further include a color filter.

[0114] The display apparatus according to the embodiment has a display section including a plurality of pixels.

[0115] The pixels each include the organic light-emitting device according to the embodiment and an active device. An example of the active device is a switching device for

controlling luminance. An example of the switching device is a TFT device.

[0116] The anode or the cathode of the organic light-emitting device is connected to the drain electrode or the source electrode of the TFT device. The display apparatus can be used as an image display apparatus of a personal computer (PC). The TFT device is disposed on the insulative surface of the substrate.

[0117] The display apparatus may be an image information processing apparatus that includes an image input section for inputting image information from an area CCD, a linear CCD, or a memory card and displays the input image on a display section.

[0118] The display section of the image information processing apparatus or the image forming apparatus may have a touch panel function. The display apparatus may be used in the display section of a multi-functional printer.

[0119] The lighting system is an apparatus for lighting, for example, a room. The lighting system may emit light of white or neutral white or light of a wavelength of blue or red light.

[0120] The lighting system according to the embodiment includes the organic light-emitting device according to the embodiment and an AC/DC converter circuit connected to the organic light-emitting device. The lighting system may

include a color filter.

[0121] The AC/DC converter circuit according to the embodiment converts AC voltage to DC voltage.

[0122] The image forming apparatus according to the embodiment includes a photosensitive member, a charging unit for charging a surface of the photosensitive member, an exposure unit for forming an electrostatic latent image by exposing the photosensitive member to light, and a developing unit for developing the electrostatic latent image formed on the surface of the photosensitive member. The exposure unit includes the organic light-emitting device of the embodiment.

[0123] An example of the exposure unit is an exposure machine including the organic light-emitting device according to the embodiment. In the exposure machine, the organic light-emitting devices may be arranged in lines. Alternatively, the exposure machine may have a configuration such that the entire exposure side emits light.

[0124] A display apparatus including the organic light-emitting device according to the embodiment will now be described with reference to Fig. 1.

[0125] Fig. 1 is a schematic cross-sectional view of a display apparatus having organic light-emitting devices according to the embodiment and TFT devices serving as switching devices connected to the organic light-emitting

devices. Fig. 1 shows two pairs of the organic light-emitting device and the TFT device. The structure will now be described in detail.

[0126] This display apparatus include a substrate 1 such as a glass substrate and a moisture-proof film 2 disposed above the substrate 1 for protecting the TFT devices or the organic compound layer. Reference numeral 3 denotes a metal gate electrode, reference numeral 4 denotes a gate insulating film, and reference numeral 5 denotes a semiconductor layer.

[0127] The TFT device 8 includes a semiconductor layer 5, a drain electrode 6, and a source electrode 7. An insulating film 9 is disposed above the TFT device 8. The anode 11 of the organic light-emitting device and the source electrode 7 are connected to each other via a contact hole 10. The display apparatus is not limited to this configuration as long as either the anode or the cathode is connected to either the source electrode or the drain electrode of the TFT device.

[0128] In Fig. 1, the multi-layer organic compound layer 12 is shown as one layer. Furthermore, a first protective layer 14 and a second protective layer 16 are disposed on the cathode 13 for preventing the organic light-emitting device from deteriorating.

[0129] The display apparatus according to the embodiment

can also use an MIM device as a switching device, instead of the transistor.

[0130] The active device of the organic light-emitting device according to the embodiment may be directly formed on a substrate such as a Si substrate. Direct formation on a substrate means that a transistor is formed by machining a substrate itself such as a Si substrate.

[0131] Such a configuration is selected depending on the resolution. For example, in a resolution of about 1-inch QVGA, the active devices are directly formed on a Si substrate. The directly formed active devices can be transistors.

[0132] It is possible to display high-quality images stably for a long time by driving the display apparatus including the organic light-emitting device according to the embodiment.

[0133] The acenaphtho[1,2-b]chrysene compound of the present invention can also be used in an in vivo label or a filter film, in addition to the organic light-emitting device.

Examples

Example 1

Synthesis of Example Compound D16

[0134] Example Compound D16 according to the embodiment was synthesized by the following method.

[0135] (1) Synthesis of intermediate compound M1

[Chem. 79]

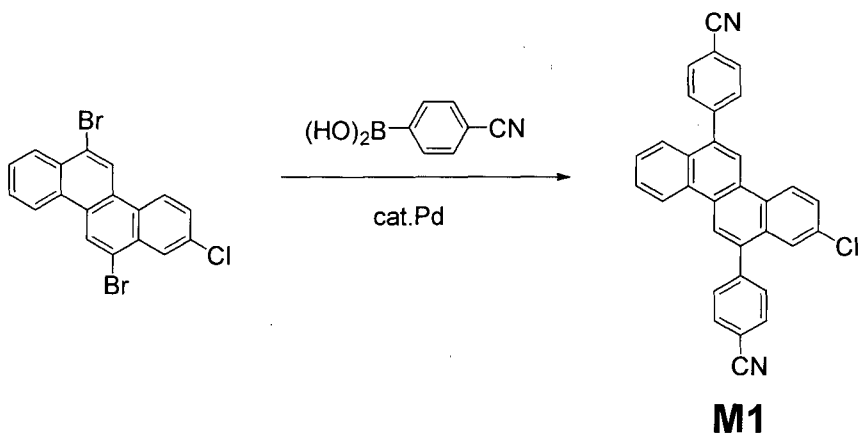

[0136] Under a nitrogen atmosphere, 45.0 g (107 mmol) of 6,12-dibromo-2-chrysenyl chloride, 33.0 g (225 mmol) of 4-cyanophenylboronic acid, 68.1 g (642 mmol) of sodium carbonate, 2700 mL of toluene, 450 mL of ethanol, 450 mL of water, and 3.71 g (3.21 mmol) of tetrakis(triphenylphosphine)palladium were sequentially placed in a 5-L separable flask and were stirred under reflux at 70°C for 5 hours.

[0137] The mixture was cooled to room temperature and was then filtered. The resulting solid residue was washed with water and acetone, and the crystals were then dried under reduced pressure to give 43.5 g (yield: 87.3 %) of intermediate compound M1.

[0138] (2) Synthesis of intermediate compound M2

[Chem. 80]

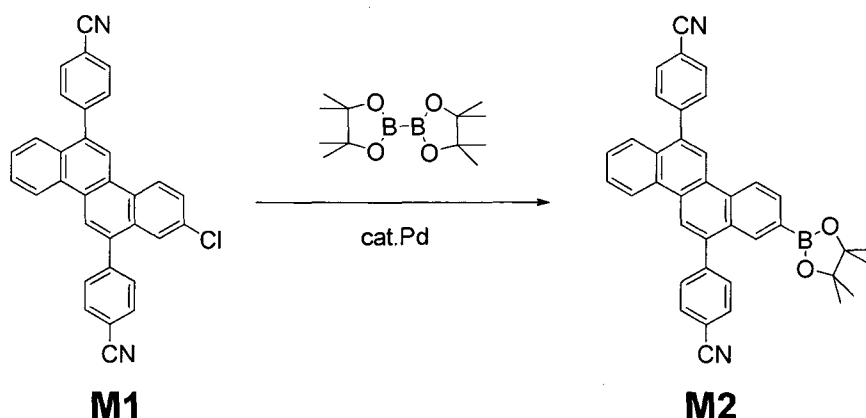

[0139] Under a nitrogen atmosphere, 42.8 g (92.1 mmol) of intermediate compound M1, 46.8 g (184 mmol) of bis-dioxaborolane, 27.1 g (276 mmol) of potassium acetate, 1.59 g (2.76 mmol) of bis(dibenzylideneacetone)palladium, and 2.72 g (6.63 mmol) of 2-dicyclohexylphosphino-2',6'-dimethoxybiphenyl were added to 4400 mL of 1,4-dioxane in a 8-L separable flask. The mixture was heated to 100°C and was then stirred at the same temperature for 10 hours.

[0140] The mixture was cooled to room temperature and 4400 mL of water added thereto. The mixture was stirred for 2 hours and was then filtered. The resulting solid residue was slurry-washed with water and methanol to give crude crystals of intermediate compound M2.

[0141] The resulting crude crystals were dissolved in 4500 mL of chlorobenzene. The solution was purified by column chromatography (chlorobenzene/ethyl acetate = 100/1), followed by slurry-washing with hot toluene. The resulting crystals were dried under reduced pressure to give 32.2 g

(yield: 62.9%) of intermediate compound M2 as white crystals.

[0142] (3) Synthesis of intermediate compound M3

[Chem. 81]

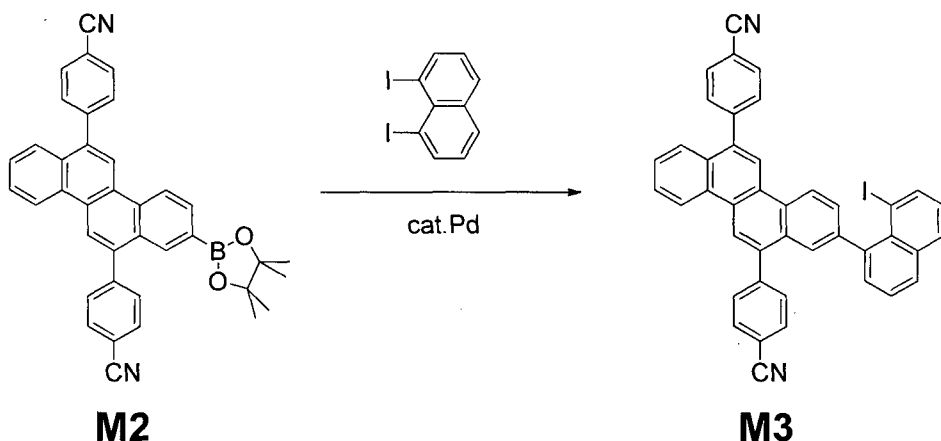

[0143] Under a nitrogen atmosphere, 11.3 g (20.3 mmol) of intermediate compound M2, 9.3 g (24.4 mmol) of 1,8-dinaphthalene, 8.6 g (81.2 mmol) of sodium carbonate, and 1.17 g (1.02 mmol) of tetrakis(triphenylphosphine)palladium were added to 1130 mL of DMSO in a 3-L three-neck flask. The mixture was heated to 80°C and was then stirred at the same temperature for 2 hours.

[0144] The mixture was cooled to 60°C and 1130 mL of water added thereto. The mixture was stirred for 1 hour and was then filtered. The resulting solid residue was slurry-washed with water and methanol to give crude crystals of intermediate compound M3.

[0145] The resulting crude crystals were dissolved in 3840 mL of chlorobenzene. The solution was purified by column chromatography (chlorobenzene), followed by slurry-washing

with hot toluene. The resulting crystals were dried under reduced pressure to give 9.50 g (yield: 78.2%) of intermediate compound M3 as yellow crystals.

[0146] (4) Synthesis of Example Compound D16

[Chem. 82]

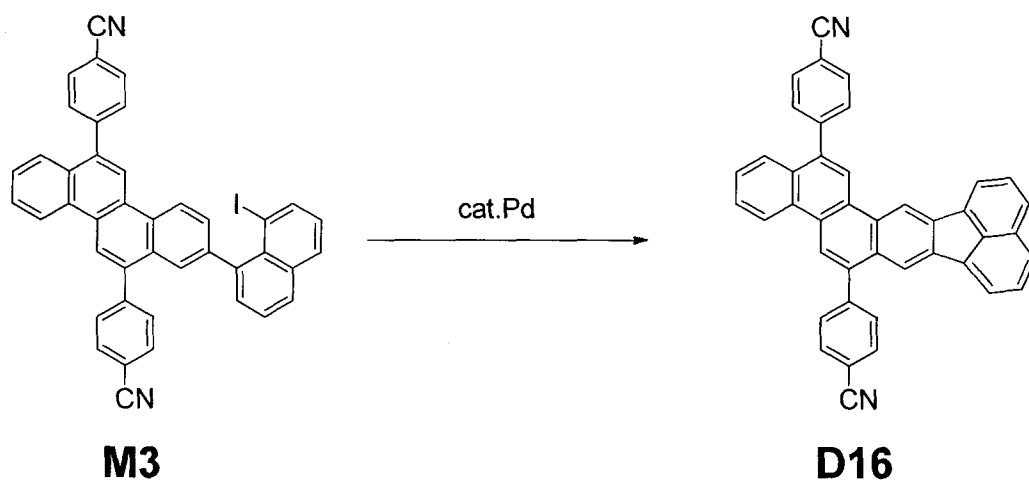

[0147] Under a nitrogen atmosphere, 9.40 g (13.8 mmol) of intermediate compound M3, 6.4 g (41.3 mmol) of 1,8-diazabicyclo[5.4.0]-7-undecene, and 0.80 g (0.68 mmol) of tetrakis(triphenylphosphine)palladium were added to 1000 mL of N,N-dimethylformamide in a 2-L three-neck flask. The mixture was heated to 136°C and was then stirred at the same temperature for 2 hours.

[0148] The mixture was cooled to 100°C and was then filtered. The resulting filtrate was cooled to room temperature and 500 mL of water was added thereto. The mixture was stirred for 1 hour and was then filtered. The resulting solid residue was slurry-washed with water and

methanol and then with hot chlorobenzene. The resulting crystals were dried under reduced pressure to give 5.84 g (yield: 78.2%) of Example Compound D16 as yellow crystals.

[0149] Mass spectrometry confirmed that Example Compound D16 had an M^+ of 544.

[0150] The structure of Example Compound D16 was confirmed by NMR measurement.

$^1\text{H-NMR}$ (CDCl_3): δ (ppm) = 9.32(s, 1H), 8.86(d, 1H, $J = 8.8$ Hz), 8.79(s, 1H), 8.66(s, 1H), 8.34(s, 1H), 8.20(d, 1H, $J = 6.8$ Hz), 7.98–7.83(m, 12H), 7.78–7.62(m, 4H).

[0151] The photoluminescence emission spectrum of a solution of 1.0×10^{-6} mol/L of Example Compound D16 in toluene was measured with a fluorospectrophotometer, F-5400, manufactured by Hitachi, Ltd., at an excitation wavelength of 399 nm. The spectrum was a blue emission spectrum having an emission peak showing a maximum intensity at 429 nm.

Example 2

Synthesis of Example Compounds D50 and D51

[0152] (1) Synthesis of intermediate compound M4

[Chem. 83]

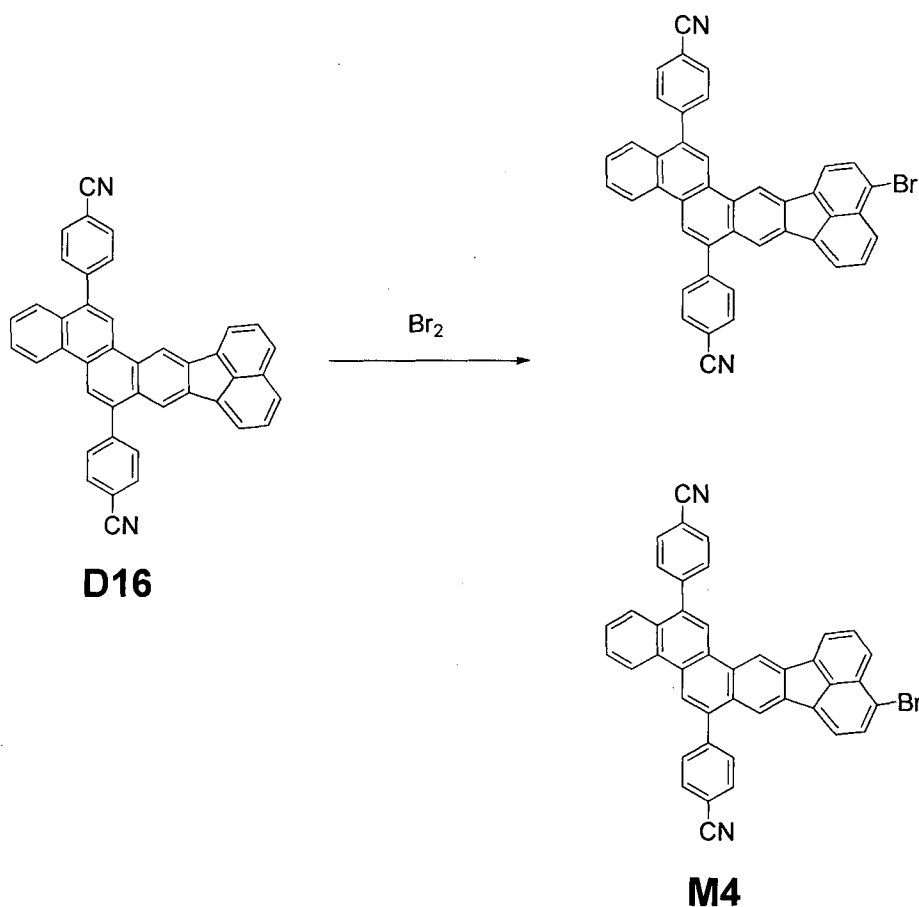

[0153] Under a nitrogen atmosphere, 5.3 g (9.52 mmol) of Example Compound D16 was added to 5300 mL of methylene chloride in a 10-L separable flask, followed by stirring for dissolution. A solution of 16.2 g (104 mmol) of bromine in methylene chloride was dropwise added to the solution, followed by stirring at room temperature for 10 hours.

[0154] A sodium thiosulfate solution was added to the resulting solution. The mixture was stirred for 1 hour and was then filtered. The resulting solid residue was slurry-washed with water and methanol and then with hot methylene chloride. The resulting crystals were dried under reduced

pressure to give 4.67 g (yield: 77.2%) of intermediate compound M4 as yellow crystals.

[0155] (2) Synthesis of Example Compounds D50 and D51

[Chem. 84]

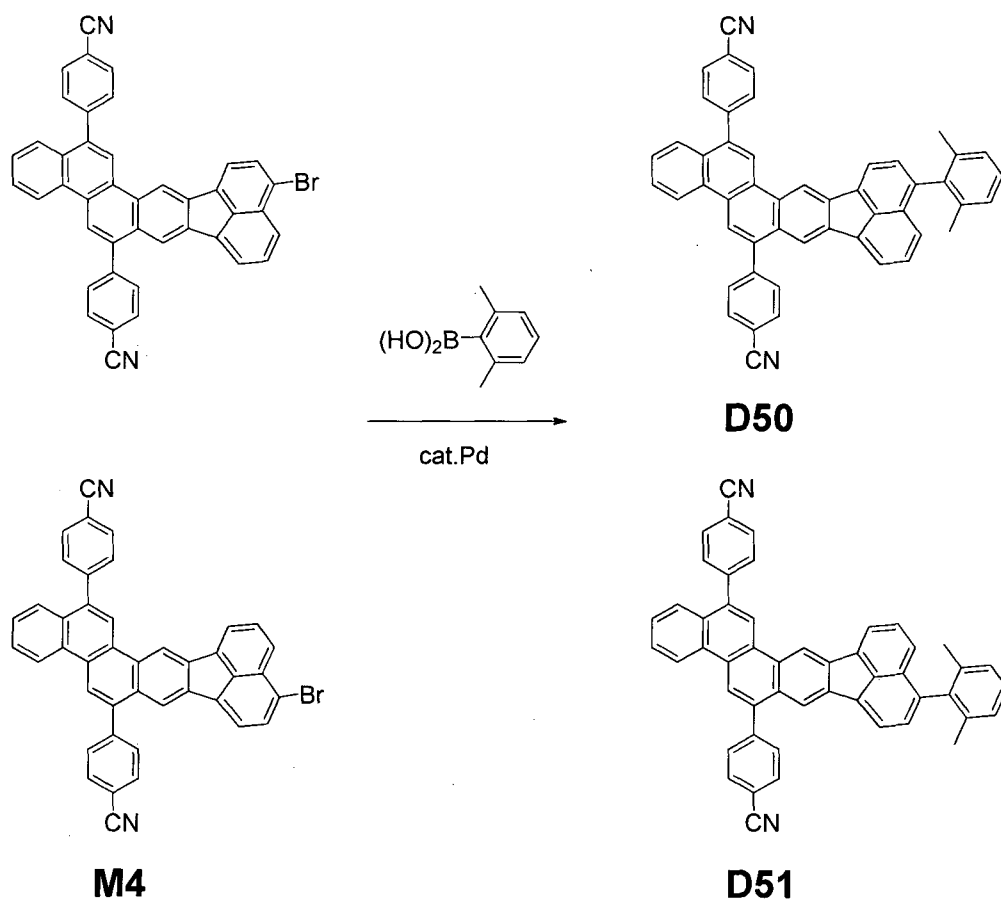

[0156] Under a nitrogen atmosphere, 1.00 g (1.58 mmol) of intermediate compound M4, 0.28 g (1.89 mmol) of 2,6-dimethylphenylboronic acid, 4.02 g (18.9 mmol) of potassium phosphate, 500 mL of N,N-dimethylformamide, and 0.18 g (0.16 mmol) of tetrakis(triphenylphosphine)palladium were sequentially placed in a 1-L three-neck flask and were heated to 100°C and then stirred at the same temperature for

11 hours.

[0157] The mixture was cooled to 80°C and was then filtered. The resulting solid residue was slurry-washed with water and methanol and then with hot chlorobenzene to give crude crystals of Example Compounds D50 and D51.

[0158] The resulting crude crystals were dissolved in 60 mL of chlorobenzene. The solution was purified by column chromatography (chlorobenzene), followed by slurry-washing with hot toluene. The resulting crystals were dried under reduced pressure to give 0.10 g (yield: 33.3%) of Example Compounds D50 and D51 as yellow crystals.

[0159] Mass spectrometry confirmed that the mixture of Example Compounds D50 and D51 had an M^+ of 658. NMR measurement confirmed that the mixture ratio of Example Compounds D50 and D51 was 1:1.

$^1\text{H-NMR}$ (CDCl_3): δ (ppm) = 9.34(s, 2H), 8.87(d, 2H, $J = 8.8$ Hz), 8.80(s, 2H), 8.67(s, 1H), 8.66(s, 1H), 8.35(s, 1H), 8.33(s, 1H), 8.19(d, 1H, $J = 6.8$ Hz), 8.12(d, 1H, $J = 6.8$ Hz), 8.04(d, 1H, $J = 6.8$ Hz), 7.97-7.84(m, 20H), 7.77(t, 2H, $J = 6.8$ Hz), 7.66-7.38(m, 8H), 7.29(t, 2H, $J = 6.8$ Hz), 7.20(d, 3H, $J = 6.8$ Hz), 1.99(s, 6H), 1.98(s, 6H).

[0160] The photoluminescence emission spectrum of a solution of 1.0×10^{-6} mol/L of the mixture of Example Compounds D50 and D51 in toluene was measured with a fluorospectrophotometer, F-5400, manufactured by Hitachi,

Ltd., at an excitation wavelength of 403 nm. The spectrum was a blue emission spectrum having an emission peak showing a maximum intensity at 433 nm.

Example 3

Synthesis of Example Compounds D62 and D63

[0161]

[Chem. 85]

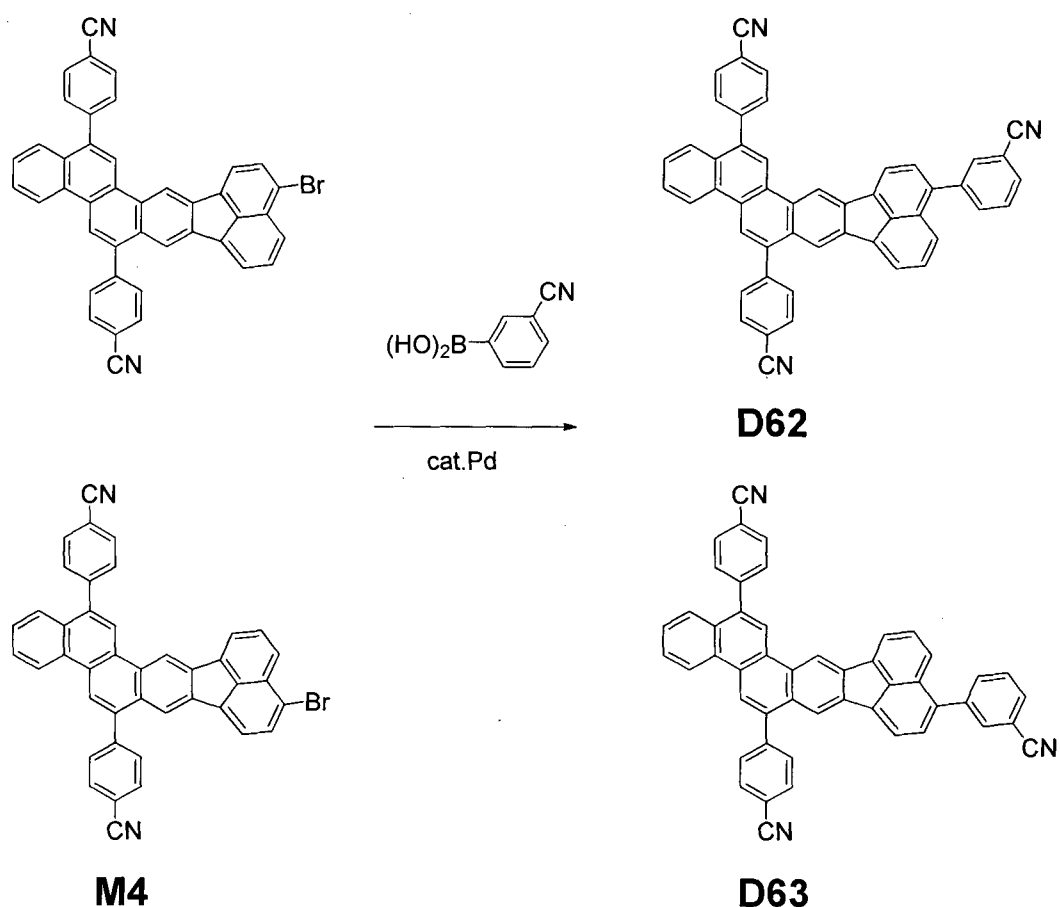

[0162] Under a nitrogen atmosphere, 0.12 g (0.19 mmol) of intermediate compound M4, 0.33 g (2.25 mmol) of 3-cyanophenylboronic acid, 0.12 g (0.57 mmol) of potassium

phosphate, 30 mL of N,N-dimethylformamide, and 0.01 g (0.01 mmol) of tetrakis(triphenylphosphine)palladium were sequentially placed in a 100-mL three-neck flask and were heated to 100°C and then stirred at the same temperature for 6 hours.

[0163] The mixture was cooled to 80°C and was then filtered. The resulting solid residue was slurry-washed with water and methanol and then with hot chlorobenzene to give crude crystals of Example Compounds D62 and D63.

[0164] The resulting crude crystals were dissolved in 80 mL of chlorobenzene. The solution was purified by column chromatography (chlorobenzene), followed by slurry-washing with hot toluene. The resulting crystals were dried under reduced pressure to give 0.02 g (yield: 16.1%) of Example Compounds D62 and D63 as yellow crystals.

[0165] Mass spectrometry confirmed that the mixture of Example Compounds D62 and D63 had an M^+ of 655. NMR measurement confirmed that the mixture ratio of Example Compounds D62 and D63 was 1:1.

$^1\text{H-NMR}$ (CDCl_3): δ (ppm) = 9.36(s, 1H), 9.35(s, 1H), 8.87(d, 2H, $J = 8.0$ Hz), 8.80(s, 2H), 8.68(s, 2H), 8.37(s, 1H), 8.36(s, 1H), 8.27(d, 1H, $J = 7.2$ Hz), 8.25(d, 1H, $J = 7.2$ Hz), 8.04-7.84(m, 26H), 7.80-7.61(m, 12H).

[0166] The photoluminescence emission spectrum of a solution of 1.0×10^{-6} mol/L of the mixture of Example

Compounds D62 and D63 in toluene was measured with a fluorospectrophotometer, F-5400, manufactured by Hitachi, Ltd., at an excitation wavelength of 407 nm. The spectrum was a blue emission spectrum having an emission peak showing a maximum intensity at 441 nm.

Example 4

Synthesis of Example Compounds D64 and D65

[0167]

[Chem. 86]

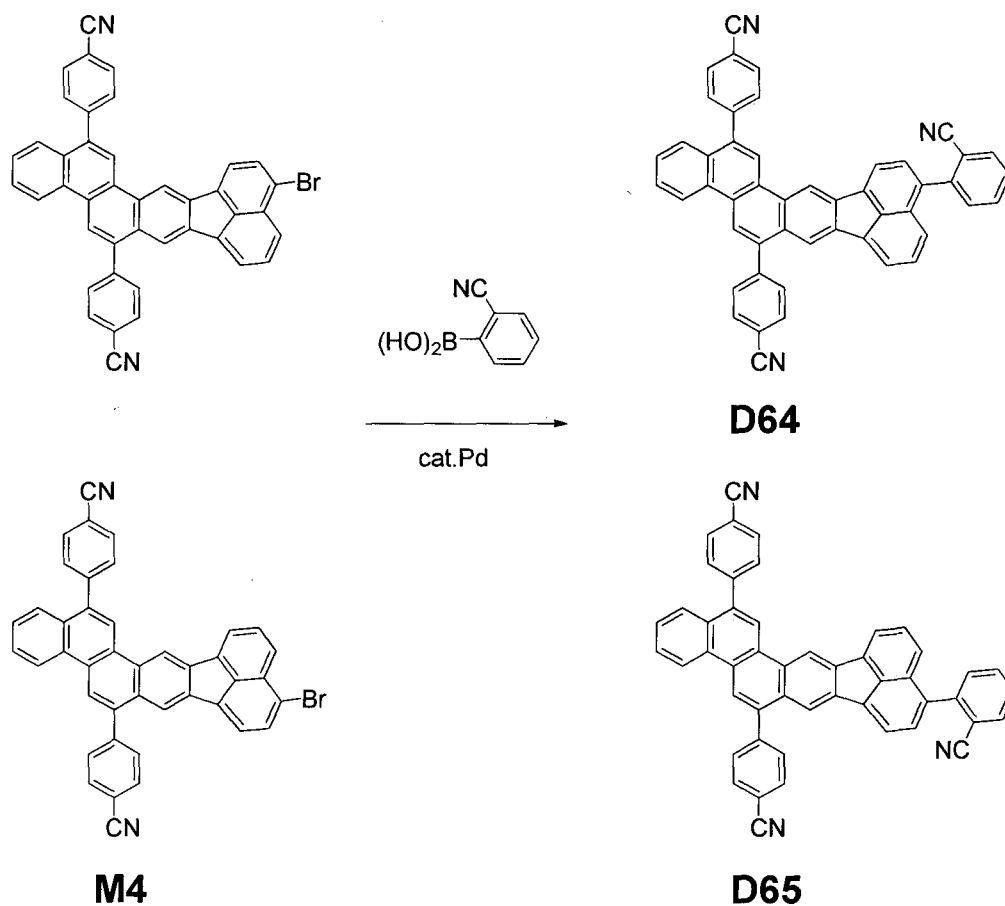

[0168] Under a nitrogen atmosphere, 1.00 g (1.58 mmol) of

intermediate compound M4, 0.28 g (1.89 mmol) of 2-cyanophenylboronic acid, 2.01 g (9.47 mmol) of potassium phosphate, 500 mL of N,N-dimethylformamide, and 0.18 g (0.16 mmol) of tetrakis(triphenylphosphine)palladium were sequentially placed in a 1-L three-neck flask and were heated to 100°C and then stirred at the same temperature for 1 hour.

[0169] The mixture was cooled to 80°C and was then filtered. The resulting solid residue was slurry-washed with water and methanol to give crude crystals of Example Compounds D64 and D65.

[0170] The resulting crude crystals were dissolved in 630 mL of chlorobenzene. The solution was purified by column chromatography (chlorobenzene), followed by slurry-washing with hot toluene. The resulting crystals were dried under reduced pressure to give 0.36 g (yield: 34.4%) of Example Compounds D64 and D65 as yellow crystals.

[0171] Mass spectrometry confirmed that the mixture of Example Compounds D64 and D65 had an M^+ of 655. NMR measurement confirmed that the mixture ratio of Example Compounds D64 and D65 was 1:1.

$^1\text{H-NMR}$ (CDCl_3): δ (ppm) = 9.32(s, 2H), 8.70(d, 2H, $J = 8.4$ Hz), 8.78(s, 2H), 8.67(s, 2H), 8.35(s, 1H), 8.33(s, 1H), 8.25(d, 1H, $J = 6.8$ Hz), 8.20(d, 1H, $J = 6.8$ Hz), 8.04(d, 2H, $J = 6.8$ Hz), 7.98-7.83(m, 20H), 7.80-7.57(m, 16H).

[0172] The photoluminescence emission spectrum of a solution of 1.0×10^{-6} mol/L of the mixture of Example Compounds D64 and D65 in toluene was measured with a fluorospectrophotometer, F-5400, manufactured by Hitachi, Ltd., at an excitation wavelength of 406 nm. The spectrum was a blue emission spectrum having an emission peak showing a maximum intensity at 441 nm.

Example 5

Synthesis of Example Compounds D80 and D81

[0173] (1) Synthesis of intermediate compound M5

As shown in synthetic route 4 below, 30 g of intermediate compound M5 was synthesized by a method described in a non-patent document: Chemistry of Materials, 2009, 21(12), 2452.

[0174] Synthetic route 4

[Chem. 87]

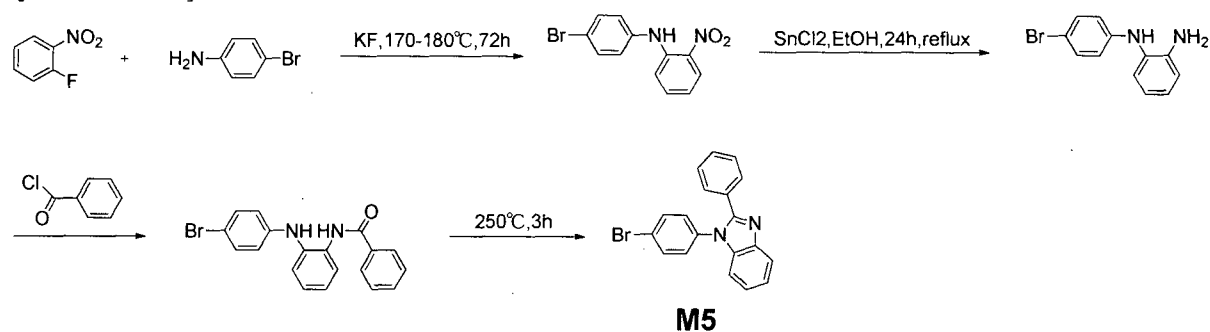

[0175] (2) Synthesis of intermediate compound M6

[Chem. 88]

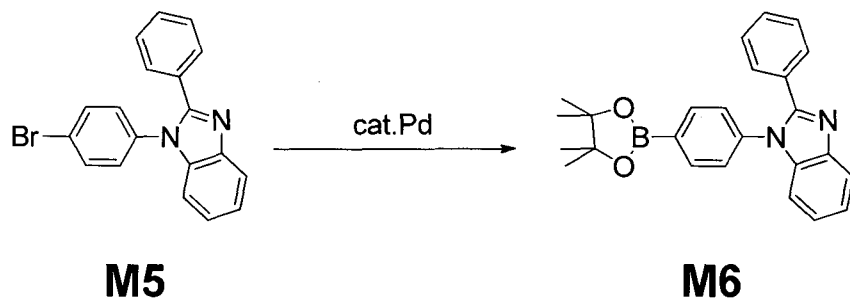

[0176] Under a nitrogen atmosphere, 5.0 g (14.3 mmol) of intermediate compound M5, 4.0 g (15.8 mmol) of bis-dioxaborolane, 4.2 g (42.8 mmol) of potassium acetate, and 0.58 g (0.71 mmol) of [1,1'-bis(diphenylphosphino)ferrocene]palladium(II) dichloride dichloromethane adduct were added to 100 mL of N,N-dimethylformamide in a 300-mL three-neck flask and were heated to 80°C and then stirred at the same temperature for 4 hours.

[0177] The mixture was cooled to room temperature and 100 mL of water added thereto. The mixture was stirred for 1 hour and was then filtered. The resulting solid residue was slurry-washed with water to give crude crystals of intermediate compound M6.

[0178] The resulting crude crystals were dissolved in toluene. The solution was purified by column chromatography (toluene/ethyl acetate = 4/1), followed by recrystallization from a solvent mixture of toluene/heptane = 4:1. The resulting crystals were dried under reduced pressure to give 4.12 g (yield: 72.7%) of intermediate compound M6.

[0179] (3) Synthesis of Example Compounds D80 and D81

[Chem. 89]

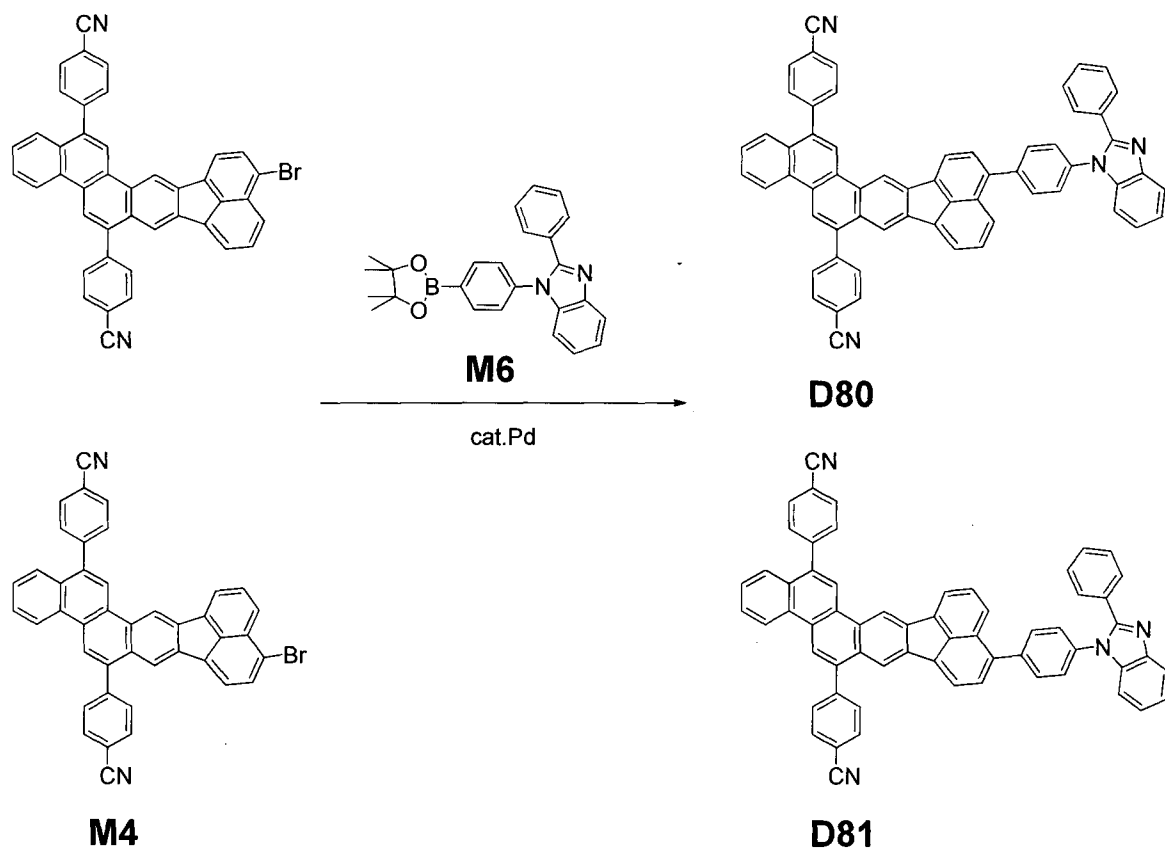

[0180] Under a nitrogen atmosphere, 0.11 g (0.17 mmol) of intermediate compound M4, 0.08 g (0.21 mmol) of intermediate compound M6, 0.11 g (0.52 mmol) of potassium phosphate, 11 mL of N,N-dimethylformamide, and 0.01 g (0.01 mmol) of tetrakis(triphenylphosphine)palladium were sequentially placed in a 1-L three-neck flask and were heated to 100°C and then stirred at the same temperature for 4 hours.

[0181] The mixture was cooled to room temperature and chloroform was added thereto, followed by washing with water

three times. The organic layer was dried with magnesium sulfate and was then filtered. The resulting filtrate was concentrated to give crude crystals of Example Compounds D80 and D81.

[0182] The resulting crude crystals were purified by column chromatography (toluene/ethyl acetate = 10/1), followed by slurry-washing with hot methanol. The resulting crystals were dried under reduced pressure to give 0.091 g (yield: 63.6%) of Example Compounds D80 and D81 as yellow crystals.

[0183] Mass spectrometry confirmed that the mixture of Example Compounds D80 and D81 had an M^+ of 822. NMR measurement confirmed that the mixture ratio of Example Compounds D80 and D81 was 1:1.

$^1\text{H-NMR}$ (CDCl_3): δ (ppm) = 9.38(s, 1H), 9.37(s, 1H), 8.88(d, 2H, $J = 8.8$ Hz), 8.82(s, 1H), 8.81(s, 1H), 8.69(s, 2H), 8.38(s, 1H), 8.37(s, 1H), 8.29(d, 1H, $J = 6.8$ Hz), 8.26(d, 1H, $J = 6.8$ Hz), 8.07-7.64(m, 38H), 7.51(d, 2H, $J = 8.8$ Hz), 8.50(d, 2H, $J = 8.8$ Hz), 7.44-7.32(m, 14H).

[0184] The photoluminescence emission spectrum of a solution of 1.0×10^{-6} mol/L of the mixture of Example Compounds D80 and D81 in toluene was measured with a fluorospectrophotometer, F-5400, manufactured by Hitachi, Ltd., at an excitation wavelength of 408 nm. The spectrum was a blue emission spectrum having an emission peak showing

a maximum intensity at 443 nm.

Example 6

Synthesis of Example Compounds D36 and D37

[0185] Reaction and purification were performed as in Example 2 except that intermediate compound M7 was used in place of 2,6-dimethylphenylboronic acid used in Example 2.

[Chem. 90]

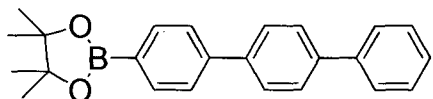

M7

[0186] The photoluminescence emission spectrum of a solution of 1.0×10^{-6} mol/L of the mixture of Example Compounds D36 and D37 in toluene was measured with a fluorospectrophotometer, F-5400, manufactured by Hitachi, Ltd., at an excitation wavelength of 410 nm. The spectrum was a blue emission spectrum having an emission peak showing a maximum intensity at 445 nm.

Comparative Example 1

[0187] Compounds R1 and R2 were synthesized as comparative examples, and photoluminescence and absorption spectra thereof were measured and were used for comparison of quantum efficiency. The absorption spectra were measured with a spectrophotometer, UV-570, manufactured by JASCO Corp. The quantum efficiency of Example Compound D16 was defined as 1.0, and those of other compounds were expressed as

relative intensities thereof. The results are shown in Table 6.

[Chem. 91]

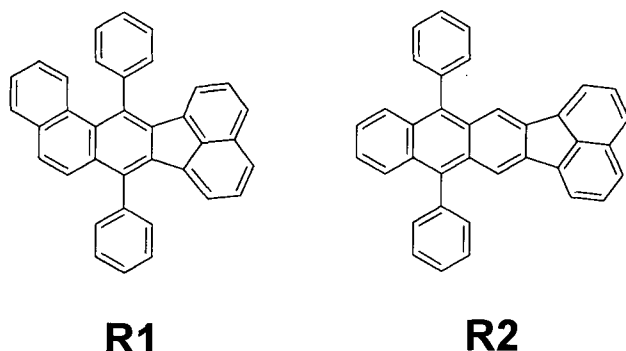

[Table 6]

	Emission wavelength (nm)	Quantum yield
Example compound D16	429	1.00
Example compound D50,51	433	1.02
Example compound D62,63	441	1.05
Example compound D64,65	441	1.04
Example compound D80,81	443	1.06
Comparative Example compound R1	430	0.98
Comparative Example compound R2	459	1.06

[0188] All of the quantum efficiencies of five example compounds of the present invention were higher than that of Comparative Compound R1.

[0189] As shown in Fig. 2, the photoluminescence spectrum of Comparative Compound R1 was compared to that of Example Compound D16 of the present invention. The height ratio of the second peak to the first peak in Comparative Compound R1 was 0.9, but the ratio in Example Compound D16 of the

present invention was low, 0.7, and the height ratios of subsequent peaks were similarly low.

[0190] That is, in Example Compound D16 of the present invention, the peak in the blue light wavelength region is the highest, and the peaks in regions other than the blue light wavelength region are low.

[0191] The results demonstrate that Example Compound D16 of the present invention has a higher emission intensity in the blue light wavelength region compared to Comparative Compound R1.

[0192] Herein, the term "first peak" refers to a peak having the highest intensity in an emission spectrum. The peaks in descending order according to intensity are referred to as the second, third, and so forth peaks.

[0193] The light emission peak wavelength of Comparative Compound R2 was compared to that of Example Compound D16 of the present invention. The peak wavelength of Comparative Compound R2 was 459 nm, but the peak wavelength of Example Compound D16 was 429 nm. That is, the light emission peak wavelength of Example Compound D16 of the present invention is shorter than that of Comparative Compound R2.

[0194] The basic skeleton itself of the fused polycyclic compound of the present invention emits shorter wavelength light compared Comparative Compound R2. Consequently, the freedom in selection of substituents is high even in the

case of maintaining the blue light emission after introduction of the substituents.

[0195] Specific examples of such a compound include four Example Compounds shown in Table 6 prepared by introducing aryl and heterocyclic group substituents into Example Compound D16 of the present invention. These compounds all emit light with a maximum emission wavelength of 450 nm or less.

[0196] That is, in the fused polycyclic compound of the present invention, the basic skeleton itself emits light in a blue region. Emission of blue light of 450 nm or less and high quantum efficiency can be achieved by appropriately selecting the introduction position of a substituent and the type of the substituent.

Examples 7 to 13

[0197] In these examples, organic light-emitting devices each having an anode, a hole-transporting layer, a light-emitting layer, a hole/exciton-blocking layer, an electron-transporting layer, and a cathode disposed in this order on a substrate were produced by the following method.

[0198] A film of ITO having a thickness of 100 nm was formed on a glass substrate by sputtering as an anode. The glass substrate provided with the anode was used as a transparent electrically conductive support substrate (ITO substrate).

[0199] On this ITO substrate, organic compound layers and electrode layers shown below were successively formed by resistance heating vacuum vapor deposition in a vacuum chamber of 10^{-5} Pa. On this occasion, the area of electrodes facing each other was adjusted to be 3 mm^2 . When two guest materials are used, the guest is a mixture of isomers having substituents at different positions at a ratio of 1:1. The layers were:

hole-injecting layer (70 nm): compound G1,

hole-transporting layer (45 nm): compound G2,

light-emitting layer (20 nm): host material: Compound G3,

guest material: Example Compound shown in Table 7 (weight ratio: 1%),

hole/exciton-blocking layer (5 nm): compound G4,

electron-transporting layer (20 nm): compound G5,

metal electrode layer 1 (1 nm): LiF, and

metal electrode layer 2 (100 nm): Al.

[Chem. 92]

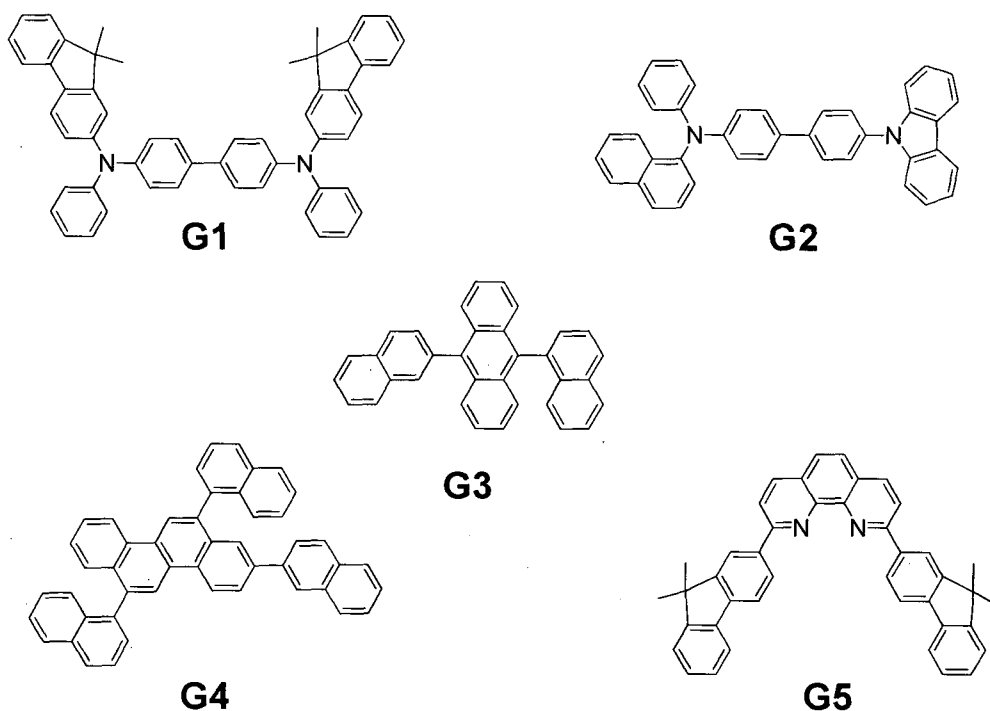

[0200] As the properties of the EL device, the current-voltage properties were measured with a micro-ammeter, 4140B, manufactured by Hewlett-Packard Company, and the light emission luminance was measured with a color luminance meter, BM7, manufactured by Topcom Corp.

[0201] The properties of EL devices of Examples 7 to 13 are shown in Table 7.

Examples 14 and 15

[0202] In these examples, organic light-emitting devices were produced as in the method shown in Examples 7 to 13 except that compound G6 was used in the hole/exciton-blocking layer.

[Chem. 93]

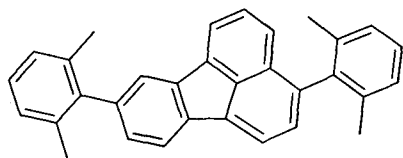
**G6****Examples 16 and 17**

[0203] In these examples, organic light-emitting devices were produced as in the method shown in Examples 7 to 13 except that compound G7 was used in the hole/exciton-blocking layer.

[Chem. 94]

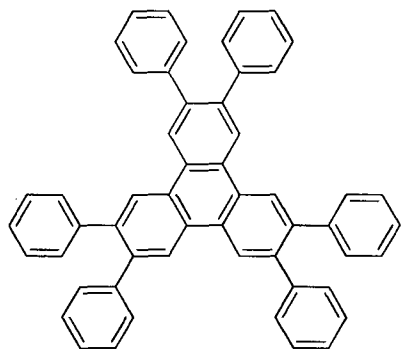
**G7****Comparative Examples 2 and 3**

[0204] In these comparative examples, organic light-emitting devices were produced as in the method shown in Examples 7 to 13 except that Comparative Compounds R1 and R2 were used as the guest materials of the light-emitting layers.

[0205] As the properties of the EL device, the current-voltage properties were measured with a micro-ammeter, 4140B,

manufactured by Hewlett-Packard Company, and the light emission luminance was measured with a color luminance meter, BM7, manufactured by Topcom Corp.

[0206] The properties of EL devices of Comparative Examples 2 and 3 are shown in Table 7.

[Table 7]

	Guest	Hole/exciton blocking layer	External quantum efficiency @10mA/cm ²	CIE chromaticity (X, Y)
Example 7	D16	G4	3.6	(0.16,0.06)
Example 8	D24	G4	3.5	(0.16,0.08)
Example 9	D27	G4	3.8	(0.15,0.12)
Example 10	D36,D37	G4	5.2	(0.15,0.13)
Example 11	D50,D51	G4	4.6	(0.15,0.07)
Example 12	D64,D65	G4	4.9	(0.15,0.11)
Example 13	D70,D71	G4	5.0	(0.15,0.12)
Example 14	D16	G6	6.1	(0.15,0.07)
Example 15	D80,D81	G6	6.2	(0.15,0.10)
Example 16	D62,D63	G7	6.8	(0.15,0.11)
Example 17	D80,D81	G7	6.7	(0.15,0.11)
Comparative Example 2	R1	G4	2.6	(0.16,0.06)
Comparative Example 3	R2	G4	4.0	(0.15,0.20)

Results and conclusion

[0207] The organic compound of the present invention is a novel compound showing a high quantum efficiency and emitting blue light, and the compound can provide an organic light-emitting device emitting light with a high color purity and high luminance.

[0208] While the present invention has been described with

reference to exemplary embodiments, it is to be understood that the invention is not limited to the disclosed exemplary embodiments. The scope of the following claims is to be accorded the broadest interpretation so as to encompass all such modifications and equivalent structures and functions.

[0209] This application claims the benefit of Japanese Patent Application No. 2012-174880, filed August 7, 2012, which is hereby incorporated by reference herein in its entirety.

Reference Signs List

- [0210]** 8 TFT device
- 11 anode
 - 12 organic compound layer
 - 13 cathode

CLAIMS

[1] A fused polycyclic compound represented by Formula [1]:

[Chem. 1]

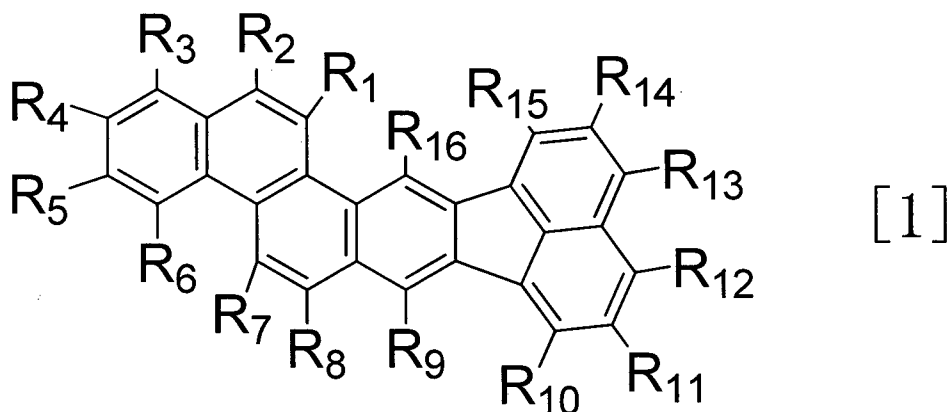

wherein, R₁ to R₁₆ each independently represent a group selected from a hydrogen atom, a cyano group, substituted or unsubstituted alkyl groups, substituted or unsubstituted aryl groups, and substituted or unsubstituted heterocyclic groups.

[2] The fused polycyclic compound according to Claim 1, wherein

at least two of R₂, R₄, R₈, R₁₂, and R₁₃ are electron-withdrawing substituents.

[3] An organic light-emitting device comprising:

a pair of electrodes; and

an organic compound layer disposed between the pair of electrodes, wherein

the organic compound layer includes a fused polycyclic compound according to Claim 1 or 2.

[4] The organic light-emitting device according to Claim 3, wherein

the organic compound layer is a light-emitting layer including a host material and a guest material; and

the guest material is the fused polycyclic compound.

[5] The organic light-emitting device according to Claim 3 or 4, wherein

the organic compound layer is a light-emitting layer including a plurality of guest materials;

at least one of the plurality of guest materials is the fused polycyclic compound; and

the device emits white light.

[6] A display apparatus comprising:

a plurality of pixels, wherein

at least one of the plurality of pixels includes an organic light-emitting device according to any one of Claims 3 to 5 and an active device connected to the organic light-emitting device.

[7] An image information processing apparatus comprising:

an image input section for inputting image information;

and

a display section for displaying an image, wherein

the display section is a display apparatus according to Claim 6.

[8] A lighting system comprising:

an organic light-emitting device according to any one of Claims 3 to 5; and

an AC/DC converter circuit connected to the organic light-emitting device.

[9] An image forming apparatus comprising:

a photosensitive member;

a charging unit for charging a surface of the photosensitive member;

an exposure unit for forming an electrostatic latent image by exposing the photosensitive member to light; and

a developing unit for developing the electrostatic latent image formed on the surface of the photosensitive member, wherein

the exposure unit includes an organic light-emitting device according to any one of Claims 4 to 7.

[10] An exposure unit for exposing a photosensitive member to light, the unit comprising:

organic light-emitting devices according to any one of Claims 3 to 5, wherein

the organic light-emitting devices are arranged in a line.

FIG. 1

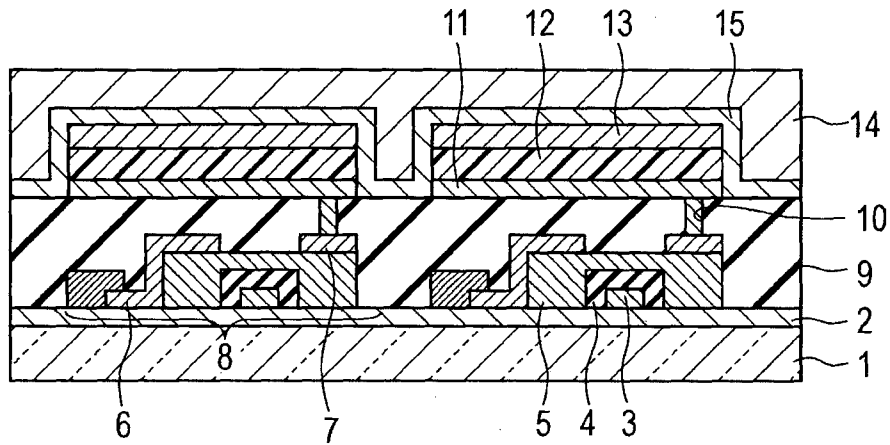
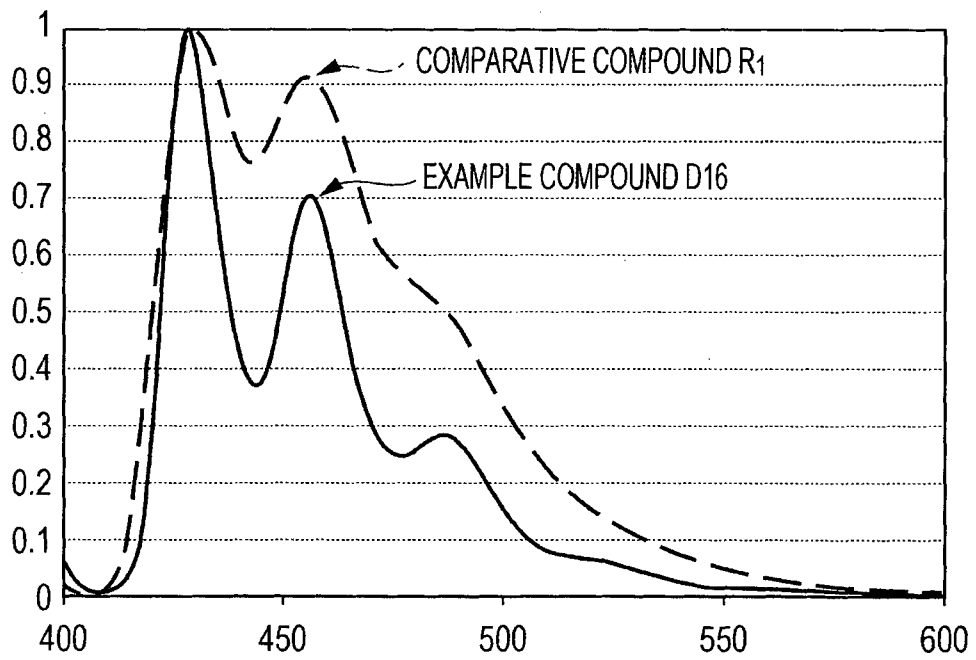

FIG. 2



INTERNATIONAL SEARCH REPORT

International application No.
PCT/JP2013/070127

A. CLASSIFICATION OF SUBJECT MATTER		
Int.Cl. C07C255/51(2006.01)i, C07D235/18(2006.01)i, C09K11/06(2006.01)i, H01L51/50(2006.01)i		
According to International Patent Classification (IPC) or to both national classification and IPC		
B. FIELDS SEARCHED		
Minimum documentation searched (classification system followed by classification symbols)		
Int.Cl. C07C255/51, C07D235/18, C09K11/06, H01L51/50		
Documentation searched other than minimum documentation to the extent that such documents are included in the fields searched Published examined utility model applications of Japan 1922-1996 Published unexamined utility model applications of Japan 1971-2013 Registered utility model specifications of Japan 1996-2013 Published registered utility model applications of Japan 1994-2013		
Electronic data base consulted during the international search (name of data base and, where practicable, search terms used)		
CAplus/REGISTRY(STN)		
C. DOCUMENTS CONSIDERED TO BE RELEVANT		
Category*	Citation of document, with indication, where appropriate, of the relevant passages	Relevant to claim No.
A	WO 2010/071224 A1 (CANON KABUSHIKI KAISHA) 2010.06.24, CLAIMS, EXAMPLES & JP 2010-143879 A & US 2011/0251446 A1 & EP 2379473 A1 & CN 102245546 A & KR 10-2011-0104026 A	1-10
A	WO 2010/067757 A1 (CANON KABUSHIKI KAISHA) 2010.06.17, CLAIMS, EXAMPLES & JP 2010-138086 A & US 2011/0240982 A1 & EP 2376407 A1 & CN 102245544 A & KR 10-2011-0101181 A	1-10
<input checked="" type="checkbox"/> Further documents are listed in the continuation of Box C. <input type="checkbox"/> See patent family annex.		
* Special categories of cited documents: "A" document defining the general state of the art which is not considered to be of particular relevance "E" earlier application or patent but published on or after the international filing date "L" document which may throw doubts on priority claim(s) or which is cited to establish the publication date of another citation or other special reason (as specified) "O" document referring to an oral disclosure, use, exhibition or other means "P" document published prior to the international filing date but later than the priority date claimed "T" later document published after the international filing date or priority date and not in conflict with the application but cited to understand the principle or theory underlying the invention "X" document of particular relevance; the claimed invention cannot be considered novel or cannot be considered to involve an inventive step when the document is taken alone "Y" document of particular relevance; the claimed invention cannot be considered to involve an inventive step when the document is combined with one or more other such documents, such combination being obvious to a person skilled in the art "&" document member of the same patent family		
Date of the actual completion of the international search	Date of mailing of the international search report	
08.11.2013	19.11.2013	
Name and mailing address of the ISA/JP	Authorized officer	4H 4507
Japan Patent Office 3-4-3, Kasumigaseki, Chiyoda-ku, Tokyo 100-8915, Japan	Naoko TAKAHASHI Telephone No. +81-3-3581-1101 Ext. 3443	

INTERNATIONAL SEARCH REPORT

International application No.
PCT/JP2013/070127

C (Continuation). DOCUMENTS CONSIDERED TO BE RELEVANT		
Category*	Citation of document, with indication, where appropriate, of the relevant passages	Relevant to claim No.
A	WO 2010/123153 A1 (CANON KABUSHIKI KAISHA) 2010.10.28, CLAIMS, EXAMPLES & JP 2010-270103 A & US 2012/0025183 A1 & EP 2421809 A1 & CN 102405200 A & KR 10-2012-0022953 A	1-10
A	JP 10-294177 A (Mitsui Chemicals, Inc.) 1998.11.04, 【0007】 (No Family)	1-10
A	JP 2005-53806 A (TDK CORP.) 2005.03.03, Claims, 【0048】 ~ 【0067】 , Examples (No Family)	1-10