

(19) World Intellectual Property Organization
International Bureau



(43) International Publication Date
17 February 2005 (17.02.2005)

PCT

(10) International Publication Number
WO 2005/015267 A2

(51) International Patent Classification⁷: G02B

(21) International Application Number:
PCT/US2004/021898

(22) International Filing Date: 9 July 2004 (09.07.2004)

(25) Filing Language: English

(26) Publication Language: English

(30) Priority Data:
10/617,572 11 July 2003 (11.07.2003) US

(71) Applicant and

(72) Inventor: BATCHKO, Robert [US/US]; 46 Calhoun Terrace, San Francisco, CA 94133 (US).

(74) Agent: ISENBERG, Joshua; 204 Castro Lane, Fremont, CA 94539 (US).

(81) Designated States (unless otherwise indicated, for every kind of national protection available): AE, AG, AL, AM,

AT, AU, AZ, BA, BB, BG, BR, BW, BY, BZ, CA, CH, CN, CO, CR, CU, CZ, DE, DK, DM, DZ, EC, EE, EG, ES, FI, GB, GD, GE, GH, GM, HR, HU, ID, IL, IN, IS, JP, KE, KG, KP, KR, KZ, LC, LK, LR, LS, LT, LU, LV, MA, MD, MG, MK, MN, MW, MX, MZ, NA, NI, NO, NZ, OM, PG, PH, PL, PT, RO, RU, SC, SD, SE, SG, SK, SL, SY, TJ, TM, TN, TR, TT, TZ, UA, UG, US, UZ, VC, VN, YU, ZA, ZM, ZW.

(84) Designated States (unless otherwise indicated, for every kind of regional protection available): ARIPO (BW, GH, GM, KE, LS, MW, MZ, NA, SD, SL, SZ, TZ, UG, ZM, ZW), Eurasian (AM, AZ, BY, KG, KZ, MD, RU, TJ, TM), European (AT, BE, BG, CH, CY, CZ, DE, DK, EE, ES, FI, FR, GB, GR, HU, IE, IT, LU, MC, NL, PL, PT, RO, SE, SI, SK, TR), OAPI (BF, BJ, CF, CG, CI, CM, GA, GN, GQ, GW, ML, MR, NE, SN, TD, TG).

Published:
— without international search report and to be republished upon receipt of that report

For two-letter codes and other abbreviations, refer to the "Guidance Notes on Codes and Abbreviations" appearing at the beginning of each regular issue of the PCT Gazette.

(54) Title: DIGITAL FOCUS LENS SYSTEM

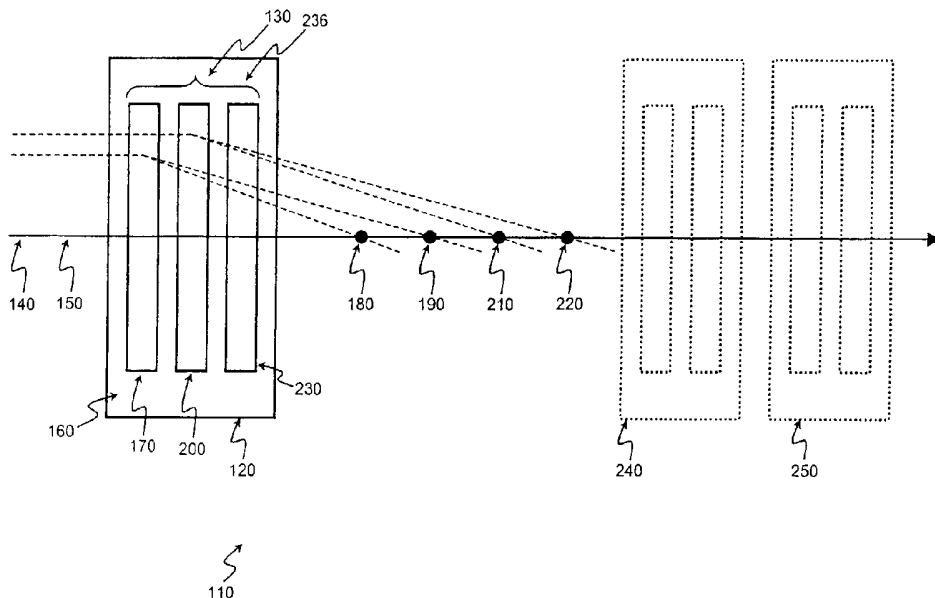

(57) Abstract: A digital focus lens systems that can provide an optical system with a plurality of selectable focal powers is described. The system includes a number of switchable elements, each of which is capable of being switched between a first state and a second state. Whereby the states represent focal powers. The switchable elements may be arranged coaxially in a stacksuch that each of them may contribute to a cumulative focal power of the system. If, for example, the system includes two such switchable elements, four focal powers for the lens system may be selected by appropriate choice the states of each switchable element. Digital telescopes, cameras, microscopes, and other optical instruments may be implemented using such digital focus lens systems. Methods of fabricating switchable elements and methods of controlling digital lens systems are also disclosed.

WO 2005/015267 A2

INTERNATIONAL PATENT APPLICATION

DIGITAL FOCUS LENS SYSTEM

FIELD OF THE INVENTION

This invention relates to optical components such as optical lens complexes and more specifically, to variable-focus lenses such as liquid crystal lenses.

BACKGROUND OF THE INVENTION

Solid-state variable-focus lens systems are needed in a variety of applications such as in cameras deployed on aircraft and subjected to strong acceleration forces. It is often desirable to have a variable-focus lens system that is compact and capable of solid-state operation; and further, one in which the number of possible states of focusing is an exponential function of the number of optical elements in the system. Conventional variable-focus lens systems are bulky, require moving parts, or require numerous elements resulting in optical losses and aberration of the images.

Thus, there is a need in the art, for a lens system that overcomes the above disadvantages.

BRIEF DESCRIPTION OF THE DRAWINGS

The teachings of the present invention can be readily understood by considering the following detailed description in conjunction with the accompanying drawings, in which:

FIG. 1 shows a digital focus lens system according to an embodiment of the present invention.

FIG. 2 shows another view of a digital focus lens system.

FIG. 3 shows yet another view of a digital focus lens system.

FIG. 4 shows yet another view of a digital focus lens system.

FIG. 5 shows another embodiment of a digital focus lens system.

FIG. 6 shows yet another embodiment of a digital focus lens system.

FIGS. 7A-7D are a sequence of cross-sectional schematic diagrams that illustrate a method for fabricating the switchable elements of a digital focus lens system according to an embodiment of the invention.

FIG. 8 shows schematic diagram illustrating a method of controlling a digital focus lens system according to an embodiment of the invention.

FIG. 9 shows a digital focus lens system incorporated in a digital telescope according to an embodiment of the invention.

5 DESCRIPTION OF THE SPECIFIC EMBODIMENTS

Although the following detailed description contains many specific details for the purposes of illustration, anyone of ordinary skill in the art will appreciate that many variations and alterations to the following details are within the scope of the invention. Accordingly, the embodiments of the invention described below are set forth without any loss of generality to,
10 and without imposing limitations upon, the claimed invention.

According to an embodiment of the present invention digital focus lens system may include a stack of switchable lens elements. The stack may include a plurality of optically transparent substrates symmetrically spaced apart, optically transparent electrodes deposited on the surfaces of each substrate, polymer layers deposited on the electrodes, and liquid crystal (LC)
15 layers filling the gaps between adjacent pairs of polymer layers. Each polymer layer may be spatially patterned to provide a selected lens function having a selected focal length, and each is treated with alignment features to facilitate orientation of the LC monomers. When a selected voltage is applied across adjacent pairs of electrodes, the refractive index of the LC layer positioned between those electrodes is switched to a selected value and the focal lengths
20 of the polymer layers adjacent to the LC layer are modulated. Thus, each group of electrode-polymer-LC-polymer-electrode layers may constitute a different switchable lens element where each can be switched between a first state, having a first focal length, and a second state, having a second focal length.

A control signal may be provided for selecting the states of the switchable lens elements. For
25 a stack of N switchable lens elements, the control signal will include a digital word comprised of at least N bits. The control signal is demultiplexed and each bit used to modulate the voltage applied to a corresponding switchable lens element. The state of each switchable lens element is thus controlled by a corresponding bit of the digital word.

The switchable lens elements can be stacked coaxially and can be switched independently to
30 either state. Thus, the system has a focal length that is determined by the instantaneous combination of states of the switchable lens elements. In the first state, the switchable lens

elements may have identical focal lengths. In the second state, the focal lengths of the switchable lens elements increase, following a progression, similar to binary weighting, in which the focal length of each sequential switchable lens element in the stack increases by a factor of 2 from that of the previous element. For a system comprising a stack of N switchable lens elements, the focal length can be selected from a set of at least 2^N values. The system thus has a focal power that is a function of the digital word contained in the control signal.

Referring now to FIG. 1, a digital focus lens system according to an embodiment of the present invention is shown and indicated generally at **110**. System **110** employs a first optical module, M_1 (first module) **120**. First module **120** incorporates a number of optical elements (elements) indicated schematically at **130**. The individual elements **130** in the module **140** are in optical communication with each other such that each element **130** in the module **140** may contribute to a cumulative optical affect. For example, the elements **130** may be oriented such that the optical axes **140** of elements **130** are generally collinear with the optical axis **150** of the system **110**. Some or all of elements **130** may be positioned in close proximity to adjacent elements. In this fashion, the elements in first module **120** may form a first stack of elements (first stack) **160**. One or more of Elements **130** may be similar to thin lenses whereby the standard thin lens approximation formulas may be applicable to portions of first stack **160** and/or first module **120**. First module **120** and/or first stack **160** may also be considered similar to a "lens group", or to a "lens complex," terms commonly used in the field of lens design.

At least one of elements **130** includes a first switchable element **170**. First switchable element **170** may be activated between a number of unique states, where for each state, first switchable element **170** is capable of performing a unique optical transform (or filter function). Preferably, first switchable element **170** may be activated between two states, however, in general, any number of states may be utilized by first switchable element **170**. Preferably, the transform performed by first switchable element **170** is similar to that of a thin lens. For example, first switchable element **170** may be activated into a first-switchable-element first-state (FSE 0-state), having the property of an FSE 0-state focal length **180**. Similarly, first switchable element **170** may be activated into a first-switchable-element second-state (FSE 1-state) having an FSE 1-state focal length **190**. First Module **120** may also incorporate a second switchable element **200**. Second switchable element **200** may be

activated into a second-switchable-element first-state (SSE 0-state), having the property of an SSE 0-state focal length **210**. Similarly, second switchable element **200** may be activated into a second-switchable-element second-state (SSE 1-state) having an SSE 1-state focal length **220**. In this fashion, First Module **120** may also incorporate a additional switchable elements **230**. In this fashion, first module **120** may incorporate a number of switchable elements, N , indicated generally at **236** whereby each switchable element may be activated between a first state (0-state) and a second state (1-state) corresponding to a first focal length and a second focal length, respectively. Examples of switchable elements **170**, **200** include without limitation liquid crystals (LCs), holographic optical elements, polymer-dispersed liquid crystals, nonlinear optical lenses, electro-optic elements, electro-optic lenses, LC lenses, LC prisms, LC gratings, LC shutters, LC aperture stops, LC irises, polymer dispersed liquid crystals, switchable holographic optical elements (HOEs), polarization rotators, isotropic, uniaxial, biaxial and/or other anisotropic optical materials, deformable mirrors and deformable gratings, and micro-electro-mechanical systems (MEMS) and MEMS mirrors. Similarly, a second module **240** and third module **250**, and in general, any number of additional modules (not shown), may be incorporated in system **110**.

Turning now to FIG. 2, a further description of the optical properties of a digital focus lens system according to an embodiment of the present invention is shown and indicated generally at **254**. The same components as in FIG. 1 have the same assigned number as in FIG. 1. System **110** includes a first module **120**. First module **120** includes a first stack **160**. First stack **160** includes a number of elements **130**. One or more of elements **130** comprise a number of switchable elements, N , **236**. For the purpose of the indexing the N switchable elements **236**, each switchable element may be assigned a unique subscript number n , where n may be chosen from the set:

$$n \in \{0, 1, \dots, N-1\}. \quad \text{Eq. 1}$$

Each switchable element n may be switched between two specified states, however, in general, any number of states may be specified.

An impulse (or "state") variable, $\delta_{m,n}(state)$, can be defined as corresponding to the state of switchable element n in module m where

$$\delta_{m,n}(state) = \begin{cases} 0 & 0\text{-state} \\ 1 & 1\text{-state} \end{cases}. \quad \text{Eq. 2}$$

For the remainder of this discussion, the parenthesis (*state*) will be dropped from the symbol $\delta_{m,n}$ for simplification. It follows that a $\delta_{m,n}$ will be specified for each switchable element n in module m . Also, it will be seen that $\delta_{m,n}$ is similar to delta functions commonly used in the field of Fourier analysis.

5 By way of example, $\delta_{1,0}$, corresponding to the state of switchable element 0 in module 1, may have the value $\delta_{m,n} = 0$ while the 0th element is activated in the 0-state, and the value 1 while activated in 1-state. Now, a switchable element focal length variable, $f_{m,n}^{\delta_{m,n}}$ is given to specify the focal length of switchable element n in module m . The parameters of $f_{m,n}^{\delta_{m,n}}$ are: a first subscript m specifying the module number; a second subscript n specifying the
 10 switchable element number and a superscript $\delta_{m,n}$ specifying the state of the n^{th} element in module m . It follows that a variable $f_{m,n}^{\delta_{m,n}}$ will be specified for each switchable element n in each module m . As illustrated in FIG. 2, the 0-state and 1-state switchable element focal lengths of switchable element $n = 2$ in module $m = 1$ are identified by $f_{1,2}^0$ and $f_{1,2}^1$, respectively. As a further example of this nomenclature, the 0-state focal length of the first
 15 switchable element **170** in the first module **120** will be referred to by the symbol $f_{1,0}^0$ **300**. The 1-state focal length of the first switchable element **170** in the first module **120** will be referred to by the symbol $f_{1,0}^1$ **310**. Similarly, the 0-state focal length of the second switchable element **200** in the first module **120** will be referred to by the symbol $f_{1,1}^0$ **320**. As a final example of the nomenclature, the 1-state focal length of the second switchable element
 20 **200** in the first module **120** will be referred to by the symbol $f_{1,1}^1$ **330**. Next, a module focal length, F_m , **256** is given for the focal length of a module where the module number is indicated by the subscript m . For example, F_1 **260** is the symbol for the module focal length **256** of the first module **120**, $m = 1$. From the above discussion, it follows that, for the case of the switchable elements being approximated as a stack of thin lenses (such when each
 25 element can be approximated as a thin lens and each is in approximate contact with any adjacent elements) and the paraxial approximation applies to the stack, the module focal length, F_m , can be expressed as

$$F_m = \left(\sum_{n=0}^{N-1} \left(\frac{\delta_{m,n}}{f_{m,n}^1} + \frac{1-\delta_{m,n}}{f_{m,n}^0} \right) \right)^{-1}. \quad \text{Eq. 3}$$

Eq. 3 can be rearranged as

$$F_m = \left[\left(\sum_{n=0}^{N-1} \frac{1}{f_{m,n}^0} \right) + \sum_{n=0}^{N-1} \delta_{m,n} \left(\frac{1}{f_{m,n}^1} - \frac{1}{f_{m,n}^0} \right) \right]^{-1}. \quad \text{Eq. 4}$$

In one embodiment of the invention, the N switchable elements in module m may be
 5 constructed such that their 1-state focal lengths, $f_{m,n}^1$, follow the mathematical form

$$f_{m,n}^1 = \left(\frac{2^n}{\Delta_m} + \frac{1}{f_{m,n}^0} \right)^{-1} \quad \text{Eq. 5}$$

where Δ_m is a constant for module m , is independent of n , and has the dimension of length.

Generally, however, in other embodiments of the invention, $f_{m,n}^1$ may be expressed by other
 mathematical forms.

10 Substituting Eq. 5 into Eq. 4 gives

$$F_m = \left[\left(\sum_{n=0}^{N-1} \frac{1}{f_{m,n}^0} \right) + \frac{1}{\Delta_m} \sum_{n=0}^{N-1} \delta_{m,n} 2^n \right]^{-1}. \quad \text{Eq. 6}$$

Now it can be seen that the second summand term in Eq. 6 will have a unique value for each
 possible combination of states $\delta_{m,n}$ for the N switchable elements 236 in module m .

Neglecting the $\frac{1}{\Delta_m}$ factor in front of the summand term of Eq. 6, the combination of possible

15 values for the summand define the set of integers

$$\sum_{n=0}^{N-1} \xi_n 2^n \in \{0, 1, \dots, 2^N - 1\}. \quad \text{Eq. 7}$$

The summand of Eq. 7 can be replaced with a dimensionless indexing variable, k ,

where k represents any value of the set of integers corresponding to the 2^N possible combinations of states for the N switchable elements in module m . Substituting Eq. 8 into Eq. 6 gives

$$F_m(k) \Big|_{k=0,1,\dots,2^N-1} = \left(\frac{k}{\Delta_m} + \sum_{n=0}^{N-1} \frac{1}{f_{m,n}^0} \right)^{-1}. \quad \text{Eq. 9}$$

5 Further, substituting Eq. 8 into Eq. 9 gives an expanded form for the module focal length

$$F_m \in \left\{ \left(\sum_{n=0}^{N-1} \frac{1}{f_{m,n}^0} \right)^{-1}, \left(\frac{1}{\Delta_m} + \sum_{n=0}^{N-1} \frac{1}{f_{m,n}^0} \right)^{-1}, \left(\frac{2}{\Delta_m} + \sum_{n=0}^{N-1} \frac{1}{f_{m,n}^0} \right)^{-1}, \dots, \left(\frac{(2^N - 1)}{\Delta_m} + \sum_{n=0}^{N-1} \frac{1}{f_{m,n}^0} \right)^{-1} \right\}. \quad \text{Eq. 10}$$

From Eq. 10 it can be seen that F_m , the effective module focal length for module m , may consist of a set of 2^N unique focal lengths.

In one embodiment, the 0-state focal lengths of all N switchable elements 236 within the same module may be identical. For this case $f_{m,n}^0$ will be constant for all values of n . Therefore, in the current embodiment, the 0-state focal lengths of all N switchable elements 236 may be expressed in the shortened form

$$f_{m,n}^0 = f_m^0 \quad \text{Eq. 11}$$

where the second subscript, n , has been dropped for simplicity due to the fact that the 0-state focal length is now independent of the value of n . Generally, however, as described above, the 0-state focal length of the N switchable elements 236 within a module may have any value.

Substituting Eq. 11 into Eqs. 9 and 10 gives simplified forms for F_m

$$F_m(k) \Big|_{k=0,1,\dots,2^N-1} = \left(\frac{N}{f_m^0} + \frac{k}{\Delta_m} \right)^{-1}, \quad \text{Eq. 12}$$

20 and in expanded form

$$F_m \in \left\{ \left(\frac{N}{f_m^0} \right)^{-1}, \left(\frac{1}{\Delta_m} + \frac{N}{f_m^0} \right)^{-1}, \left(\frac{2}{\Delta_m} + \frac{N}{f_m^0} \right)^{-1} \dots \left(\frac{(2^N - 1)}{\Delta_m} + \frac{N}{f_m^0} \right)^{-1} \right\}. \text{ Eq. 13}$$

A module focal power for module m may be introduced as

$$P_m = F_m^{-1}. \text{ Eq. 14}$$

Substituting Eq. 14 into Eqs. 12 and 13 gives

$$5 \quad P_m(k) \Big|_{k=0,1,\dots,2^N-1} = \frac{N}{f_m^0} + \frac{k}{\Delta_m} \text{ Eq. 15}$$

and in expanded form

$$P_m \in \left\{ \left(\frac{N}{f_m^0} \right), \left(\frac{1}{\Delta_m} + \frac{N}{f_m^0} \right), \left(\frac{2}{\Delta_m} + \frac{N}{f_m^0} \right) \dots \left(\frac{(2^N - 1)}{\Delta_m} + \frac{N}{f_m^0} \right) \right\}. \text{ Eq. 16}$$

From Eqs. 12 and 15 it can be seen that F_m and P_m (where k has been dropped from both functions for simplicity) are functions of the indexing variable k . It thus follows from these equations, and from Eqs. 13 and 16, that the module focal length F_m , and module focal power P_m , of module m are selectable from a set of 2^N focal lengths for the switchable elements. It also follows that each focal length (or focal power) corresponds to a unique combination of states for the N switchable elements in module m . In this sense, module m is capable of performing a “quantized zoom” function in that its module focal length (or focal power) may be varied between a number of quantized focal lengths (or focal powers). The addition of other optical elements, such as conventional lenses, in the module will affect the F_m and P_m in a fashion that will be understood by those skilled in the art.

In another embodiment of the invention the 0-state focal length of each of the N switchable elements in module m may be fixed at a distance of infinity,

$$20 \quad f_m^0 = \infty \text{ mm. Eq. 17}$$

Substituting Eq. 17 into Eqs. 12, 13 and 16 gives the following expressions for module focal length and module focal power. For the focal length,

$$F_m(k) \Big|_{k=0,1,\dots,2^N-1} = \frac{\Delta_m}{k}, \text{Eq. 18}$$

and in expanded form

$$F_m \in \left\{ \frac{\Delta_m}{0}, \frac{\Delta_m}{1}, \frac{\Delta_m}{2}, \dots, \frac{\Delta_m}{2^N-1} \right\}; \quad \text{Eq. 19}$$

and, in terms of focal power

$$5 \quad P_m(k) \Big|_{k=0,1,\dots,2^N-1} = \frac{k}{\Delta_m}, \text{Eq. 20}$$

and in expanded form

$$P_m \in \left\{ \left(\frac{0}{\Delta_m} \right), \left(\frac{1}{\Delta_m} \right), \left(\frac{2}{\Delta_m} \right), \dots, \left(\frac{2^N-1}{\Delta_m} \right) \right\}. \quad \text{Eq. 21}$$

Referring now to FIG. 3, a digital focus lens system according to another embodiment of the present invention is shown and indicated generally at **700**. Lens system **700** includes an optical module **710**. Although only a single module **710** is shown in the figure, any number of modules may be incorporated in the system **700**. Module **710** has an input face **712** for receiving input light generally indicated by **714** directed into module **710**. Light **714** may be coherent or incoherent, and may originate from light sources including without limitation, light emitting diodes (LEDs), spatial light modulators, scanners, lasers, light bulbs, natural lighting (for example, sunlight), images (such as those generated by such LED or liquid crystal arrays or other optical systems such as telescopes, displays or microscopes). Similarly, module **710** has an output face **716** for emitting output light generally indicated at **718** which has been transmitted through module **710**. Module **710** comprises an optical element stack **719**. Stack **719** includes a number of optical elements, preferably in generally close proximity and orientation to one another such that the standard analytic approximations well known in the field of optics may apply. Such approximations include without limitation, thin lens and paraxial approximations.

Stack **719** may comprise a first sub-stack **720**. First sub-stack **720** may comprise a number of non-switchable elements **740**, **742**. While only two non-switchable elements **740**, **742** are

shown in FIG. 3, any number of non-switchable elements may be incorporated. Preferably, each of the non-switchable elements **740**, **742** comprises a number of optical elements which are capable of performing the functions of a thin lens, however, any refractive, diffractive, reflective or other conventional optical elements for the modulation of phase, frequency and/or amplitude of electromagnetic radiation may be employed. For example, non-switchable elements **740**, **742** may include without limitation, mirrors, lenses, diffraction gratings, prisms, polarizers, faraday rotators, biaxial crystals, optical films and coatings, optical gain media, nonlinear optical materials, spatial filters, wavelength-selective filters, holographic optical elements, or other conventional on-axis or off-axis optical elements.

5
10
15

Preferably, each of the non-switchable elements **740**, **742** are capable of performing phase modulation functions similar to that of a lens, and will have a specific F#, optical axis **748**, **749**, and focal length. Some or all of the focal lengths of non-switchable elements **740**, **742** may be identical or unique from the others. Preferably, the optical axes **748**, **749** are collinear. Alternatively, non-switchable elements **740**, **742** may comprise a single non-switchable element **760**.

Lens stack **719** may further comprise a second sub-stack **730**. Second sub-stack **730** may comprise a stack of switchable elements, indicated at **750**, **752**, **754**. While only three switchable elements **750**, **752**, **754** are shown, any number of switchable elements may be incorporated. Preferably, each switchable element **750**, **752**, **754** comprises a variable focal length- or switchable-lens, however, any switchable refractive, diffractive, reflective or other optical elements for the modulation of phase, frequency and/or amplitude of electromagnetic radiation may be employed. As discussed previously, examples of switchable elements include without limitation liquid crystals (LCs), holographic optical elements, polymer-dispersed liquid crystals, nonlinear optical lenses, electro-optic elements, electro-optic lenses, LC lenses, LC prisms, LC gratings, LC shutters, LC aperture stops, LC irises, polymer dispersed liquid crystals, switchable holographic optical elements (HOEs), polarization rotators, isotropic, uniaxial, biaxial and/or other anisotropic optical materials, deformable mirrors and deformable gratings, and micro-electro-mechanical systems (MEMS) and MEMS mirrors. The number of switchable elements **750**, **752**, **754** and the number of non-switchable elements **740**, **742** may be identical or different. Preferably, each of the switchable elements **750**, **752**, **754** are capable of performing phase modulation functions similar to that of a number of lenses, and will have specific F#'s, optical axes, and focal

20
25
30

lengths. Each of the switchable elements **750, 752, 754** may be switched between at least a specific first state (“0-state”) and a specific second state (“1-state”).

While only two states (0-state and 1-state) are discussed here for each of switchable elements **750, 752, 754**, any number of states may be employed. Preferably, for each of the switchable elements **750, 752, 754** the 0-state corresponds to a specific first focal length (0-state focal length) having a 0-state optical axis **758, 759, 760** and 0-state F#. Likewise, for each of the switchable elements **750, 752, 754** the 1-state corresponds to and a specific second focal length (1-state focal length) having a 1-state optical axis **762, 763, 764** and a 1-state F#. Preferably, the 0-state focal lengths for the switchable elements **750, 752, 754** are identical and at a distance of infinity. However, any 0-state focal lengths may be employed by switchable elements **750, 752, 754**. Each of the switchable elements **750, 752, 754** will preferably have a specific F#, optical axis **758**, and focal length for each of the 0-states and 1-states. Preferably, 1-state focal length for each of switchable elements **750, 752, 754** will be unique and will follow the relation similar to that described in Eq. 5 above. Preferably, the optical axes **748, 749, 758, 759, 760, 762, 763, 764** are collinear. Preferably, first sub-stack **720** and second sub-stack **730** are preferably of nominal thickness and in close contact with one another such that approximations, well known in the field of optics, including without limitation the thin-lens-close-contact approximations may apply to elements in both stacks **720, 730**. Preferably, switchable elements **750, 752, 754** may be activated in any combination of 1-states and 0-states simultaneously. In this fashion, module **710** may have a module focal length generally corresponding to the inverse of the sum of inverse focal lengths of switchable elements **750, 752, 754**. It also follows that the module focal length will be selectable from a prescribed set of possible values. Preferably, the module focal length will follow relations similar to those described in Eqs. 3, 4, 6, 9, 10, 12, 13, 18 and 19 above.

Switchable elements **750, 752, 754** are connected to control cable **770**. Control cable **770** connects to controller **772** which provides energy (such as voltage, current, or charge) and control signals for activating and selecting the states of switchable elements **750, 752, 754**. Preferably, each of switchable elements **750, 752, 754** are fabricated and arranged such that each of the 1-state focal lengths serves to focus light **718** at a corresponding focal point which is at a unique distance from output face **716**. When input light **714** is generally collimated, or originates from a light source an approximately infinite distance from input face **712**, output

light **718** will be focused at a point located at a distance from output face **716** approximately equal to the module focal length.

The following examples will use the previously discussed notation $F_m(k)$ to describe the module focal length; the subscript m indicates the module number, and the number “ k ” in parentheses specifies the index number for the module focal length that has been selected from the set of possible values (see Eqs. 8, 9, 10, 12, 13, 18 and 19, above). For example, in the preferred embodiment, when all elements **750**, **752**, **754** are activated in the 0-states, module **710** will have a module focal length $F_m(0)$ and the transmitted light may be focused at a point A located a generally infinite distance from output face **716** and indicated by ray **780**.

Alternatively, however, system **700** may be configured such that point A is located at a finite distance from output face **716**. When element **750** is in the 1-state and elements **752**, **754** are in the 0-states, the module focal length will correspond to $F_m(1)$ and light **718** may be focused at a point B . When element **752** is in the 1-state and elements **750**, **754** are in the 0-states, the module focal length will correspond to $F_m(2)$ and light **718** may be focused at a point C . When elements **750**, **752** are in the 1-states and element **754** is in the 0-state, the module focal length will correspond to $F_m(3)$ and light **718** may be focused at a point D . When element **754** is in the 1-state, and elements **752**, **754** are in the 0-states, the module focal length will correspond to $F_m(4)$ and light **718** may be focused at a point E . When elements **750**, **754** are in the 1-states and element **752** is in the 0-state, the module focal length will correspond to $F_m(5)$ and light **718** may be focused at a point F . When elements **752**, **754** are in the 1-states and element **750** is in the 0-state, the module focal length will correspond to $F_m(6)$ and light **718** may be focused at a point G .

Finally, when all elements **750**, **752**, **754** are activated in the 1-states and no elements are in the 0-states, the module focal length will correspond to $F_m(7)$ and light **718** may be focused at a point H . Controller **772** may also provide signals such that any portion of switchable elements **750**, **752**, **754** are activated simultaneously in any combination of states. In this fashion, elements **750**, **752**, **754** may perform any combination of 0-state and 1-state optical functions simultaneously. Further, the relative portions of light **714**, **718** that is modified by 0-states and 1-states of elements **750**, **752**, **754** may be determined by controller **772**. In this fashion, the module **710** may simultaneously have a plurality of module focal lengths and light **718** may be focused simultaneously at combinations of points A , B , C , D , E , F , G , and

H. The module focal length can also be expressed in terms of a module focal power, $P_m(k)$, similar to the relationships described in Eqs. 14, 15, 16, 20, 21 above.

The module focal power, $P_m(k)$, may be selected from a set of values that are determined by the combination of states of elements **750, 752, 754**. The possible values for $P_m(k)$ comprise a sequence of values, similar to the relation described in Eq. 20; in this fashion, the value (or, “state”) of the module focal power is a linear function of the value of k . It follows from this that, since k is a value (or “state”) indicating the combination of states of the switchable elements, the module focal power is thus a function of the combination of states of the switchable elements.

Referring now to FIG. 4, a stack of switchable elements according to an embodiment of the present invention is shown and indicated generally at **800**. Stack **800** includes switchable elements, generally indicated at **750, 752, 754**. While three elements **750, 752, 754** are shown, any number may be employed in stack **800**. Elements **750, 752, 754** may each include a liquid crystal lens interposed between substrates **832, 834, 836, 838**. Substrates **832, 834, 836, 838** are at least partially transparent to light **820, 830** transmitted through stack **800**. Substrates **832, 834, 836, 838** may comprise glass, plastic, acrylic resin, polymer, crystal, thin films or other materials known to provide a structure for layered electro-optic devices. Substrates **832, 834, 836, 838** each have a first substrate surface and a second substrate surface **839 and 840, 842 and 844, 846 and 848, 850 and 852**, respectively. At least a portion of substrate surfaces **839, 840, 842, 844, 846, 848, 850, 852** can include an antireflection coating as may be desirable for minimizing the loss of light **820, 830** transmitted through stack **800**. At least a portion of substrate surfaces **840, 842, 844, 846, 848, 850** are deposited with a generally transparent electrical conductor such as indium tin oxide or conducting polymer. Deposited on the conductive substrate surfaces **840, 842, 844, 846, 848, 850** are lens function layers **860, 862, 864, 866, 868, 870**. Lens function layers **860, 862, 864, 866, 868, 870** may consist of materials that may be patterned and include without limitation polymer, epoxy, polymer-dispersed liquid crystal, poly (methyl methacrylate) (PMMA) or photoresist. Lens function layers **860, 862, 864, 866, 868, 870** are at least partially transparent to light **820, 830** transmitted through stack **800**. A portion of the lens function layers **860, 862, 864, 866, 868, 870** also are patterned such that the thickness, index of refraction, transmittance, scattering, absorption or other optical property of each layer spatially varies, and, in turn, may perform a phase, amplitude and/or frequency

modifying function on light transmitted through the layers. Lens function layers **860, 862, 864, 866, 868, 870** may be patterned using techniques that include without limitation as optical lithography, electron-beam lithography, UV light exposure, holographic, laser or other interferometry, or contact pattern transfer from a patterned substrate to a portion of the lens function layers. Preferably, lens function layers **860, 862, 864, 866, 868, 870** are patterned with a lens function including without limitation, the optical properties of lenses such as thin, thick, Fresnel, concave, convex, binary, diffracting, a spheric, on-axis, off-axis, cylindrical, holographic and other lenses. Lens function layers **860, 862, 864, 866, 868, 870** may also include alignment grooves or additional alignment layers to provide a desired orientation or alignment of liquid crystal monomers. Lens function layers **860, 862, 864, 866, 868, 870** are preferably separated by spacers **880, 881, 882, 883, 884, 885**. Spacers **880, 881, 882, 883, 884, 885** serve to provide cells **890, 892, 894** between adjacent pairs of layers **860, 862, 864, 866, 868, 870**, and may comprise such materials as Mylar, photoresist, glass fiber, glass or plastic spheres or other films or materials of generally uniform or controlled thickness. At least a portion of cells **890, 892, 894** are filled with liquid crystal fluid **900, 902, 904**. Liquid crystal **900, 902, 904** may include without limitation one or more of a liquid crystal material, liquid crystal, doped liquid crystal, doped liquid crystal material, a nematic liquid crystal, a nematic liquid crystal material, a smectic liquid crystal, a smectic liquid crystal material, a ferroelectric liquid crystal, a ferroelectric liquid crystal material or a polymer dispersed liquid crystal material. Conductor surfaces **840, 842, 844, 846, 848, 850** are connected to control cables **910, 912, 914**. Control cables **910, 912, 914** are connected to controller **772**. Controller **772** provides voltage to control cables **910, 912, 914** and provides electric fields across pairs of conducting surfaces **840, 842, 844, 846, 848, 850** which control the molecular orientation of liquid crystal **900, 902, 904**.

By way of example, switchable elements **750, 752, 754** may be configured similar to conventional nematic liquid crystal cells having parallel homogeneous alignment. Considering element **750** when no electric field is applied across conducting surfaces **840, 842**, molecules of liquid crystal **900** are aligned such there exists a first refractive-index mismatch between liquid crystal **900** and layers **860, 862**. This first refractive-index mismatch results in element **750** having a first focal length (0-state focal length) for light **820** of a specific polarization. In the presence of an electric field across conducting surfaces **840, 842**, molecules of liquid crystal **900** are aligned such there exists a second refractive-index mismatch between liquid crystal **900** and layers **860, 862**. This second refractive-index

mismatch results in element **750** having a second focal length (1-state focal length) for light **820** of a specific polarization. Similarly, element **752** will have a 0-state focal length with no electric field applied across conducting surfaces **844**, **846**, and will have a 1-state focal length in the presence of an electric field. Likewise, element **754** will have a 0-state focal length with no electric field applied across conducting surfaces **848**, **850**, and will have a 1-state focal length in the presence of an electric field. Additional switchable elements **920** may be included in stack **800**. Alternately, the 0-state and 1-state focal lengths may correspond to the presence and absence of electric fields, respectively. The relationship between the state of focal length and the absence, or presence, of the applied electric field may depend on factors including without limitation, orientation of alignment grooves, types of liquid crystal, refractive indexes of lens function layers, the amplitude, frequency and direction of displacement fields in the liquid crystal, amplitude and frequency of applied electric fields and voltage potentials across the cells and the polarization of light **820**. Additional elements **920** may include without limitation liquid crystal lenses similar to those described above, polarizers, liquid crystal- or other- variable apertures or field stops, tunable color filters, variable polarization rotators and retarders, deformable mirrors and MEMS devices. Further, additional non-switchable elements **760** may be included in stack **800**. Preferably, 0-state focal lengths of each of elements **750**, **752**, **754** will be approximately infinity; this may be accomplished, for example, when the lens function layers **860**, **862**, **864**, **866**, **868**, **870** are generally index-matched to the extra-ordinary index of the corresponding liquid crystal **900**, **902**, **904**. Alternatively, switchable elements **750**, **752**, **754** may be configured similar to other liquid crystal configurations, including without limitation twisted or super-twisted nematic liquid crystal cells whereby the focusing properties of the switchable lenses are generally independent of the polarization of the light **820**.

Preferably, 1-state focal lengths of each of elements **750**, **752**, **754** will follow relationships similar to the 2^n relationships described in Eq. 5 above. For example, the 0-state focal lengths of elements **750**, **752**, **754** may all be infinite. However, elements **750**, **752**, **754** may have 1-state focal lengths with values of $\frac{\Delta_m}{2^0}$, $\frac{\Delta_m}{2^1}$ and $\frac{\Delta_m}{2^2}$, respectively, where Δ_m is a constant having the dimension of length. It follows that, in the present example, Δ_m may be equal to the 1-state focal length of element **750** ($f_{m,0}^1$). In this fashion, elements **750**, **752**, **754** may have 1-state focal lengths of $f_{m,0}^1$, $\frac{f_{m,0}^1}{2}$, $\frac{f_{m,0}^1}{4}$, respectively.

Turning now to FIG. 5, an alternative embodiment of the stack of switchable elements is shown and generally indicated at **1000**. The same components as in FIG. 4 have the same assigned number as in FIG. 4. Stack **1000** includes a plurality of switchable elements, indicated generally at **750, 752, 754**. A first transparent substrate **832** has a first conductive surface **840** that is at least partially coated with an optically transparent, electrically conductive layer such as indium tin oxide. Conductive surface **840** is at least partially deposited with a first lens function layer **860**. First lens function layer **860** may have a number of optical phase- and/or amplitude- modifying functions embedded in it. Additionally, first lens function layer **860** may have alignment grooves or features for providing liquid crystal monomer alignment. First spacers **880, 881** are deposited on first lens function layer **860** and have a controlled thickness. Second lens function layer **862** is deposited on spacers **880, 881** thereby forming a first cell **890**. Second lens function layer **862** may also have a number of optical phase- and/or amplitude- modifying functions imbedded in it. Second lens function layer **862** is deposited on a second conductive surface **1180**. Second conductive surface **1180** is deposited on a first transparent film **1100**. First transparent film **1100** may be comprised of optically transparent materials including without limitation glass, vinyl-acetate, thin coat sputtered- or evaporated- films, plastic or polymer. First transparent film **1100** may include an optical phase- and/or amplitude- modifying function, such as a lens function, imbedded in it. A third lens function layer **864** is deposited on first transparent film **1100**. Third lens function layer **864** may include a number of optical phase- and/or amplitude- modifying functions imbedded in it. Second spacers **882, 883** are deposited on third polymer layer **864**.

A fourth lens function layer **866** is deposited on second spacers **882, 883** thereby forming a second cell **892**. Fourth lens function layer **866** may include a number of optical phase- and/or amplitude- modifying functions. Fourth lens function layer **866** is deposited on a third conductive surface **1182**. Third conductive surface **1182** is deposited on a second transparent film **1102**. Second transparent film **1102** may be comprised of optically transparent materials including without limitation glass, vinyl-acetate, plastic or polymer. Second transparent film **1102** may include an optical phase modifying function imbedded in it. A fifth lens function layer **868** is deposited on second transparent film **1102**. Fifth lens function layer **868** may include a number of optical phase- and/or amplitude- modifying functions. Third spacers **884, 885** are deposited on fifth polymer layer **868**. A sixth lens function layer **870** is deposited on third spacers **884, 885** thereby forming a third cell **894**. Sixth lens function

layer **870** may include a number of optical phase- and/or amplitude- modifying functions imbedded in it. Sixth polymer layer **870** is deposited on a fourth conductive surface **1184**. Fourth conductive surface **1184** is deposited on a second transparent substrate **1200**. Liquid crystal material **1206**, **1207**, **1208** is deposited in cells **890**, **892**, **894**, respectively. Liquid
5 crystal may include one or more of a liquid crystal material, liquid crystal, doped liquid crystal, doped liquid crystal material, a nematic liquid crystal, a nematic liquid crystal material, a smectic liquid crystal, a smectic liquid crystal material, a ferroelectric liquid crystal, or a ferroelectric liquid crystal material.

Conductor surfaces **840**, **1180**, **1182**, **1184** are connected to control cables indicated generally
10 at **1210**. Control cables **1210** are connected to controller **1220**. Second conducting surface **1180** functions as a common electrode to switchable elements **750** and **752**. Likewise, third conducting surface **1182** functions as a common electrode to switchable elements **752** and **754**. Controller **1220** provides voltages to control cables **1210** such that electric fields formed across elements **750**, **752**, **754** are of appropriate modulation, amplitude and sign such
15 that the liquid crystal monomers in cells **890**, **892**, **894**, become aligned to desired orientations. In this fashion, switchable elements **750**, **752**, **754** function as independently switchable lenses. Also, in this fashion, any number of similar switchable elements may be incorporated in stack **1000**.

Preferably the thickness of the optical components in between first substrate **832** and second
20 substrate **1200** is of appropriate thickness, relative to parameters such as the numerical apertures of the lens functions of switchable elements, and the wavelengths of light transmitted through stack **1000**, such that the thin-lens-close-contact approximations, known in the field of geometric optics, can be applied. For example, with no electric field applied across conducting surfaces **1180**, **1182** and no electric field applied across surfaces **1182**,
25 **1184**, switchable elements **752**, **754** are in the 0-states, and hence may function as lenses having infinite focal lengths. With the proper electric field applied across conducting surfaces **840**, **1180**, switchable element **750** is switched to the 1-state, and hence may function as a lens having a finite focal length, of, for example, $f_{m,0}^1$. In this fashion, light
30 **1210** emitted from light source **1238**, and is transmitted through stack **1000**, will be focused at a point *B*. Under these same conditions, but with an electric field now also applied across conducting surfaces **1182**, **1184**, liquid crystal monomers **1230** become aligned such that switchable element **754** is switched to the 1-state, and hence may function as a lens having a

finite focal length, of, for example, $\frac{f_{m,0}^1}{4}$. In this fashion, for example, light input light indicated at **1239** is emitted from light source **1238**. Input light **1239** is transmitted through stack **1000** and is transmitted as light generally indicated as **1250**. In this fashion transmitted light **1250** may therefore be redirected by switchable elements **750**, **754**, and may be focused at a point *F*. Generally, in this fashion, for the various combinations of states for the three switchable elements **750**, **752**, **754**, given in this example, transmitted light **1250** may be focused at focal points indicated at *A*, *B*, *C*, *D*, *E*, *F*, *G*, and *H*.

Alternatively, some or all of switchable elements **750**, **752**, **754** may be configured such that, with appropriate applied voltages, the focal lengths may be continuously tunable instead of being selectable for a discrete set of focal lengths. For example, such continuously tunable configurations may include without limitation nematic liquid crystal cells in parallel homogeneous alignment and electro-optic lenses.

Alternatively, focal points *A*, *B*, *C*, *D*, *E*, *F*, *G*, and *H* may comprise focal planes whereby the transmitted light **1250** forms a virtual or real image at focal planes *A*, *B*, *C*, *D*, *E*, *F*, *G*, and *H*. While only three switchable elements **750**, **752**, **754** are described here, any number of *N* switchable elements may be incorporated in embodiments of the present invention. In this fashion, the number of selectable focal points may increase proportionally with the function 2^N .

Turning now to FIG. 6, an alternative embodiment of the stack of switchable elements is shown and generally indicated at **1000'**. The same components as in FIG. 5 have the same assigned number as in FIG. 5. Stack **1000** includes a plurality of switchable elements, indicated generally at **750**, **752**, **754**. A first transparent substrate (first substrate) **832** has a first optically transparent, electrically conductive surface **840**. First conductive surface **840** is at least partially deposited with a first lens function layer **860**. First lens function layer **860** has an optical phase- and/or amplitude- modifying function, such as a lens, prism, grating, or other optical function, imbedded in it and may include without limitation materials such polymer, epoxy, PMMA and photoresist.

First spacers **880**, **881** are deposited on lens function layer **860** and have a controlled thickness. A second lens function layer **862** is deposited on spacers **880**, **881** thereby forming a first cell **890**. Second lens function layer **862** is deposited on a first electrically conductive substrate **1410**. First electrically conductive substrate (first conductive substrate) **1410**

provides both electrical conductivity and structural support to element 750 and to stack 1400 in general. A third lens function layer 864 is deposited on first conductive substrate 1410. Second spacers 882, 883 are deposited on third lens function layer 864.

A fourth lens function layer 866 is deposited on second spacers 882, 883 thereby forming a
5 second cell 892. Fourth lens function layer 866 is deposited on a second electrically
conductive substrate 1420. Second electrically conductive substrate (second conductive
substrate) 1420 provides both electrical conductivity and structural support to element 752
and to stack 1400 in general. A fifth lens function layer 868 is deposited on second
conductive substrate 1420. Third spacers 884, 885 are deposited on fifth layer 868. A sixth
10 lens function layer 870 is deposited on third spacers 884, 885 thereby forming a third cell
894. Sixth lens function layer 870 is deposited on a second conductive surface 1184. Fourth
conductive surface 1184 may be deposited on a second transparent substrate (second
substrate) 1200. Generally, in a similar fashion, first substrate 832 may be at least partially
electrically conductive, such that first substrate 832 and first conductive surface 840 may be
15 combined into a single substrate (not shown). Likewise, second substrate 1200 may be at
least partially electrically conductive, such that second substrate 1200 and second conductive
surface 1184 may be combined into a single substrate (not shown). Liquid crystal material
1206, 1207, 1208 is deposited in cells 890, 892, 894, respectively. Conductive surfaces (and
conductive substrates) 840, 1410, 1420, 1184 are connected to control cables indicated
20 generally at 1210. Control cables 1210 are connected to controller 1220. Alternatively, a
portion of lens function layers 860, 862, 864, 866, 868, 870 may include a partially
conductive surface (not shown) or may be coated with a conducting film (not shown) such
that the conducting surface or film is in near contact with a portion of the liquid crystal
material 1206, 1207, 1208. Additionally, a portion of lens function layers 860, 862, 864, 866,
25 868, 870 may have alignment grooves, coatings or features for providing liquid crystal
monomer alignment.

Turning now to FIGs. 7a-7d, a die-stamping replication method for fabricating the portions of
the switchable elements, specifically, the layered structure that includes a substrate, a
conductive layer and a lens function layer. The same components as in FIG. 4 have the same
30 assigned number as in FIG. 4. As shown in FIG. 7a, a transparent substrate 832 has a first
substrate surface 1305. First substrate surface 1305 has deposited on it an optically
transparent, electrically conductive surface (or, conductive layer) 840 such as ITO.

Conductive layer **840** may be deposited by sputtering or by other known techniques. Deposited on conductive layer **840** is a lens function layer **860**. Lens function layer **860** may include patternable materials including without limitation polymer, epoxy, photoresist or PMMA. Lens function layer **860** may be spin-coated on conductive layer **840**. Lens function layer **860** may be deposited in such a fashion as to have a generally uniform thickness, yet will be soft or viscous for a period of time before it is hardened by baking, exposure to ultraviolet (UV) light or other hardening processes. A die substrate **1300**, is comprised of substrate material that is capable of being patterned or micromachined, including without limitation, glass, plastic, silicon or other substrate materials. Die substrate **1300** has a first die surface **1310**. First die surface **1310** has a spatially-varying thickness pattern **1320**. While lens function layer **860** is in its soft or viscous state, die substrate **1300** is brought toward it, indicated schematically by an arrow **1330**.

Now referring to FIG. 7b, die substrate **1300** is brought into contact with lens function layer **860**. In this fashion, first die surface **1310** is stamped (FIG. 7b) onto phase modifying layer **860** so as to transfer an inverse-copy of spatially-varying thickness pattern **1320** into lens function layer **860**. A release agent (not shown), such as a silicone spray, may be deposited on one or more of the first die surface **1310** and the lens function layer **860**. The release agent may serve to assist in release of the die substrate **1300** from the lens function layer **860** in later steps of the process. This arrangement is then subjected to a hardening force **1340**, such as heat that emanates from a heat source (not shown), or from UV light emanating from a UV source (not shown). Hardening force **1340** serves to harden the lens function layer **860**. Now referring to FIG. 7c, after lens function layer **860** has been sufficiently hardened, die substrate **1300** (not shown) is removed. Lens function layer **860** will now have stamped into it an inverse-copy of spatially-varying thickness pattern **1350**. With appropriate die, lens function layer **860** can perform phase-modifying functions such as lens functions and other functions including refraction, diffraction, reflection and scattering. Now turning to FIG. 7d, this method can be generally repeated using a second substrate surface **1306** of substrate **832**, or using a plurality of substrates (not shown). In this fashion, a second lens function layer **1360**, or a plurality of lens function layers (not shown) can be patterned, each its own specific phase- and/or amplitude- modifying properties.

Referring now to FIG. 8, a method for controlling the states of the switchable elements of embodiments of the present invention is shown and generally indicated at **1500**. The same

components as in FIG. 3 have the same assigned number as in FIG. 3. A signal, generally indicated at *S*, is generated and provided to controller 772. Signal *S* contains information for controlling the states of switchable elements 750, 752, 754. Signal *S* may be either generated either internally or externally to controller 772. A portion of signal *S* includes a serial data stream comprising a control word, indicated generally at 1520. Control word 1520 is digital word having a bit field length of *N* bits where *N* may be a number equal to the number of switchable elements 750, 752, 754 in stack 716.

In the current example (FIG 8), control word 1520 may comprise a 3-bit field length where the bits are generally indicated at *A*, *B*, *C*, and has the base-two value "101". However, in general, control word 1520 can have any bit field length and may be comprised of any number of groups of bits. A demultiplexer 1530 serves to demultiplex control word 1520 whereby each of bits *A*, *B*, *C* are routed to a separate port, indicated generally at *A'*, *B'*, *C'*. Each port *A'*, *B'*, *C'* is connected to additional electronics (not shown) including a voltage source (not shown) that are, in turn, connected to a separate switchable element 750, 752, 754. In this fashion, bit *A* provides a signal for controlling the state of switchable element 750, bit *B* provides a signal for controlling the state of switchable element 752, and bit *C* provides a signal for controlling the state of switchable element 754. Thus, control word 1520, serves to control the states (or the, "combination of states") of the switchable elements 750, 752, 754. As was described in FIG. 3, the module focal power (or the state thereof) is a function of the combination of states of the switchable elements. Therefore, the state of the module focal power is a function of the value of control word 1520.

Digital Telescope Lens System.

Referring now to FIG. 9, the digital focus lens system is applied to a two-lens telescope system. It will be seen that the present embodiment of the invention similar to a simple Galilean telescope having digitally variable focal length, or zoom, properties. A digital zoom lens system (system) 400 incorporates a first module 410 having a first focal length, F_1 420. System 400 further incorporates a second module 430 having a second focal length, F_2 440. Second module 430 is located a first distance, d_1 450, from first module 410. One or more of the first module 410 and second module 430 may incorporate a number of optical elements (elements) 460, 464. One or more of elements 460 may include switchable elements 470, 474 and may be activated into a number of states. The optical axes, generally indicated at 480, of first module 410, second module 430, and elements 460, 470, 474, 464 may be

generally collinear. Alternatively, the optical axes of first module **410**, second module **430**, and elements **460**, **470**, **474**, **464** may be arranged at any relative orientations. In the present embodiment, one or more of elements **470** are similar to thin lenses in close proximity or in contact with one another, and the thin lens and/or the paraxial approximations may apply to portions of first module **410** and/or second module **430**.

A first object **490** and a first image **500** are located at distances s_{o1} **510** and s_{i1} **520**, respectively, from first module **410**. Likewise, a second object **530** and second image **540**, are located at distances s_{o2} **550** and s_{i2} **560**, respectively, from second module **430**. Using the standard lensmakers formula, s_{i1} **520** and s_{i2} **560** can be expressed as

$$s_{o1} = \left(\frac{1}{F_1} - \frac{1}{s_{i1}} \right)^{-1} \quad \text{Eq. 22}$$

and

$$s_{o2} = \left(\frac{1}{F_2} - \frac{1}{s_{i2}} \right)^{-1}. \quad \text{Eq. 23}$$

Using the definition of s_{o2} **550** similar to that conventionally used in simple two-lens systems

$$s_{i1} \equiv d_1 - s_{o2}, \quad \text{Eq. 24}$$

s_{o1} **510** can be expressed in a form similar to that of common two-lens systems

$$s_{o1} = \frac{F_1[s_{i2}(d_1 - F_2) - d_1 F_2]}{s_{i2}(d_1 - F_1 - F_2) + F_2(F_1 - d_1)}. \quad \text{Eq. 25}$$

A parameter of system **400**, the magnification, M , (or, transverse magnification, M_T), is similar to the magnification of a simple two-lens system, i.e.,

$$M \equiv M_T = \frac{-s_{i1}}{s_{o1}} \cdot \frac{-s_{i2}}{s_{o2}}. \quad \text{Eq. 26}$$

Substituting for s_{i1} **520** and s_{o2} **550**, M can now be expressed as

$$M = \frac{F_2 F_1}{s_{o1}(d_1 - F_1 - F_1) + F_1(F_2 - d_1)}, \quad \text{Eq. 27}$$

again, similar to the transverse magnification for standard two-lens systems.

Now, for a zoom lens system such as a telescope or telephoto lens, it may be desirable for s_{i2} **560** to be a generally fixed distance from second module **430** while s_{o1} **510** is variable over a

specified range of distances from first module 410. In this fashion, a system focal length 570, given as the distance between s_{o1} 510 and s_{i2} 560, is a variable. However, it is often difficult to construct such a system in which M , s_{i2} 560 and d_1 450 are all constant while s_{o1} 510 is variable. In a present embodiment of the invention, a telescope based on combinatorial optics is enabled in which M , s_{i2} 560 and d_1 450 are constant while s_{o1} 510 is variable.

To accomplish this, for example, F_1 420 may be constant and F_2 440 may be variable and expressed as a function of k , i.e., $F_2(k)$, and given a form similar to that described in Eq. 12,

$$F_2(k) \Big|_{k=0,1,\dots,2^N-1} = \left(\frac{N}{f_2^0} + \frac{k}{\Delta_m} \right)^{-1}, \quad \text{Eq. 28}$$

where, for this example, the 0-states of the N switchable elements 474 of the second module 430 are identical. Substituting Eq. 28 into Eq. 27 gives an expression for M as a function of the variable k , i.e., $M(k)$,

$$M(k) \Big|_{k=0,1,\dots,2^N-1} = \left(-\frac{N}{f_2^0} - \frac{k}{\Delta_m} + \left(\frac{d_1 N}{f_2^0} - \frac{f_2^0 \Delta_m - d_1 k f_2^0}{f_2^0 \Delta_m} \right) \frac{1}{F_1} \right) s_{i2} + 1 - \frac{d_1}{F_1}. \quad \text{Eq. 29}$$

Setting the first derivative of $M(k)$ with respect to k equal to 0, i.e.,

$$\frac{\partial M(k)}{\partial k} = 0 \quad \text{Eq. 30}$$

a solution is found for F_1 420

$$F_1 = d_1. \quad \text{Eq. 31}$$

Substituting Eqs. 31 and 28 into Eq. 25 gives

$$s_{o1(k)} = \left(\frac{-k}{\Delta_m} + \frac{1}{s_{i2}} - \frac{N}{f_2^0} \right) d_1^2 + d_1. \quad \text{Eq. 32}$$

Substituting Eq. 31 into Eq. 29, gives and M as constant,

$$M = -\frac{s_{i2}}{d_1}. \quad \text{Eq. 33}$$

An object separation constant, δs_{o1} 580, having the dimension of length, can be defined as the derivative of s_{o1} 510 with respect to k , i.e.,

$$\delta s_{o1} \equiv \frac{\partial s_{o1(k)}}{\partial k} = -\frac{d_1^2}{\Delta_m}. \quad \text{Eq. 34}$$

An initial object plane $s_{oI(0)}$ **590**, i.e., the value of $s_{oI(k)}$ for $k = 0$, can be expressed as

$$s_{oI(0)} = d_1 - \frac{Nd_1^2}{f_2^0} + \frac{d_1^2}{s_{i2}} \tag{Eq. 35}$$

Substituting Eqs. 34 and 35 into Eq. 32 gives

$$s_{oI(k)} \Big|_{k=0,1,\dots,2^N-1} = s_{oI(0)} + \delta s_{oI} k \tag{Eq. 36}$$

5 and in expanded form

$$s_{oI} \in \{ \{s_{oI(0)}\}, (s_{oI(0)} + \delta s_{oI}), \dots, (s_{oI(0)} + \delta s_{oI} [2^N - 1]) \} \tag{Eq. 37}$$

From the above discussion, it can be seen that the present embodiment of the invention is similar to a telescope with quantized or “digital” zoom control of the focal length. In particular, system **400** is similar to a Galilean telescope, wherein: F_1 **420** and F_2 **440** are similar to the field lens and ocular lens, respectively; wherein d_I **450** is similar to the distance separating F_1 **420** and F_2 **440**; and wherein M , s_{oI} **510** and s_{i2} **560** are similar to the transverse magnification, object distance and image distance, respectively. However, the present embodiment of the invention has the following distinctive properties: s_{oI} **510** is selectable from a set of quantized locations relative to the location of F_1 **420**; the relative locations of F_1 **420** and F_2 **440** may be fixed such that d_I **450** may have a constant value for all object distances in the set of s_{oI} ; s_{i2} **560** and M may both have constant values for all object distances in the set of s_{oI} ; and the system and its components may be solid state, i.e., comprise no moving parts.

Digital Camera Lens System.

20 In cases where s_{i2} has a negative value, the image formed by the system is a virtual image and the system can function similarly to simple two-lens telescope. In this fashion, remote objects may be viewable by the human eye and may not require additional optical elements for viewing such as oculars. However, when s_{i2} has a positive value, the image formed by the system is a real image and the system may function as an imaging system such as a camera.

25 For example, the system may function as a camera wherein an image sensor (sensor) may be positioned a distance s_{i2} from F_2 . Such sensors may include, without limitation, CCD arrays, CMOS image sensors or sensor arrays, artificial retinas or conventional photographic film. In this fashion, information, pertaining to the image of an object located at a distance s_{oI} from F_1 , may be captured by the sensor.

Additional optical elements may be incorporated in all embodiments of the invention in fashions similar to those used commonly in telescopes, cameras and other imaging and non-imaging systems or in other ways that will be understood by those skilled in the art. Examples of such additional optical elements may include without limitation oculars, field
5 lenses, and apertures, stops, partially- or fully- reflective mirrors, prisms, gratings, lenses, and lens complexes.

Digital Projector Lens System.

In another embodiment of the present invention, the system may be configured to function as an image projector. For example, with 2-lens image projectors, generally, an object is located
10 at a distance, s_{o1} , from an object lens, L_1 ; an image is formed at a distance, s_{i2} , from an image lens L_2 ; and L_1 and L_2 are separated by a distance d_1 . Similarly to telescopes, for image projectors it is sometimes desirable for both the separation distance between the two optical elements d_1 and the magnification M to have constant values. In the previous preferred embodiment of a digital telescope lens system, s_{i2} was held constant while s_{o1} was variable.
15 However, for the present embodiment of a digital projector lens system, it may be desirable that s_{i2} , be variable while s_{o1} is held constant. To accomplish this functionality, the previous embodiment of the invention is utilized, however, the system may now be flipped relative to the positions of the object and the image. In this fashion, the F_2 , may be left constant and F_1 , may now be variable and expressed as a function of the variable k , and given a form similar
20 to that described above and in Eq. 12.

Digital Microscope Lens System.

The above discussions described embodiments of the invention that utilize digital focus lens systems for purposes that include the controlling of the position of an image without
25 requiring changes in the magnification of the image, and while simultaneously allowing the system to be solid state. Similarly, however, it may also sometimes be desirable for the system to exhibit properties such as allowing the control of the magnification of an image without requiring changes in the location of the image, and while simultaneously allowing the system to be solid state.

30 For example, for microscopes in general, and specifically for 3-lens microscopes, an object may be located at a distance, s_{o1} , from a first module. A second module may be located at a first distance d_1 from the first module. A third module may be located at a second distance d_2

from the second module. An image may then be formed at an image distance s_{i3} from the third module. In the present embodiment of a 3-lens microscope, it may be desirable for d_1 , d_2 , s_{o1} , and s_{i3} to all have generally constant values, while it may also be desirable that the magnification, M , may be variable.

5 In the previous embodiments, M and d_1 were held constant while either s_{o1} or s_{i2} were variable. However, for the present embodiment of a combinatorial optical microscope, the magnification M will now be variable while s_{o1} , s_{i3} , d_1 and d_2 , will be held generally constant. One way to accomplish this functionality incorporates the previous embodiment of the invention, a digital projector lens system and a third module having variable focal power. As
 10 in the previous embodiment, the focal length of the second module F_2 may be left constant. Further, the first module may incorporate switchable elements as previously described. In this fashion the focal length of the first module F_1 may be variable and expressed as a function of k , and given the form similar to that described in Eq. 12.

A solution may be found for which the first derivative of s_{i3} with respect to k is equal to zero,
 15 i.e.,

$$\frac{\partial s_{i3}}{\partial k} = 0.$$

In this fashion, the distance of the image to the third module will be a constant and independent of the state of variable k . One possible solution to the above condition exists for the case when the focal power of at least one of the modules is continuously variable between
 20 two specified values of focal power. The magnification, M , (or, transverse magnification, M_T) of this three-module system may also be similar to the magnification of a common three-lens system, similar to the previous discussion of M for a two-module system,

$$M \equiv M_T = \frac{-s_{i1}}{s_{o1}} \cdot \frac{-s_{i2}}{s_{o2}} \cdot \frac{-s_{i3}}{s_{o3}}.$$

The desired functionality of M being a variable function of k , $M(k)$, can be achieved for a
 25 system utilizing a module, for example, the third module, the focal length, F_3 , of which is a variable function of k . Ways to achieve this functionality include without limitation the use of electro-optic or liquid crystal lenses or other variable or switchable optical elements that have generally continuously variable focal power. For example, for a material having an r_{33} or other electro-optic coefficient, such as lithium niobate, may be polished in the form of a
 30 lens. Transparent electrodes, such as indium tin oxide, may be deposited on the surfaces of

the lens. An electric field may then be applied from one electrode to the other, across the thickness of the lens. Due to the electro-optic coefficient of the material of the lens, the index of the lens will be a function of the strength of the applied electric field. In this fashion, the focal length of the lens will also be a function of the applied electric field. Similarly, liquid
5 crystal (LC) lenses and gratings, such as modal LCs and LC lenses similar to LC blazed-grating beam deflectors based on nematic LC cells in parallel homogeneous alignment can provide variable focusing of the above form.

It will be understood by those skilled in the art of optics that many additional optical
10 elements, components, complexes, etc., may be included in the present invention; those additional elements have been omitted from this discussion for simplicity.

While the above is a complete description of the preferred embodiment of the present invention, it is possible to use various alternatives, modifications and equivalents. Therefore, the scope of the present invention should be determined not with reference to the above
15 description but should, instead, be determined with reference to the appended claims, along with their full scope of equivalents. The appended claims are not to be interpreted as including means-plus-function limitations, unless such a limitation is explicitly recited in a given claim using the phrase "means for."

WHAT IS CLAIMED IS:

- 1 1. A Digital Focus Lens System for providing an optical system having a plurality of
2 selectable focal powers, comprising:
3 a first switchable element capable of being switched between a first-element first-state
4 and a first-element second-state; and
5 and a second switchable element capable of being switched between a second-element
6 first-state and a second-element second-state;
7 wherein the first and second switchable elements are in optical communication with each
8 other such that each of them may contribute to a cumulative focal power,
9 wherein, a first focal power may be selected by activation of the first switchable element
10 to the first-element first-state and activation of the second switchable element to the
11 second-element first-state,
12 wherein a second focal power is selected by activation of the first switchable element to
13 the first-element second-state and activation of the second switchable element to the
14 second-element first-state,
15 wherein a third focal power is selected by activation of the first switchable element to the
16 first-element first-state and activation of the second switchable element to the second-
17 element second-state, and
18 wherein a fourth focal power is selected by activation of the first switchable element to
19 the first-element second-state and activation of the second switchable element to the
20 second-element second-state.
- 1 2. The system according to Claim 1 wherein a portion of the switchable elements include
2 liquid crystal lenses.
- 1 3. The system according to Claim 1 wherein a portion of the switchable elements include
2 switchable holographic optical elements.
- 3 4. The system according to Claim 1 wherein a portion of the switchable elements include
4 polymer dispersed liquid crystal.
- 5 5. The system according to Claim 1 wherein a portion of the switchable elements form a lens
6 stack.

- 1 6. The system according to Claim 1 further comprising one or more non-switchable
2 elements for further modifying the optical properties of the system.
- 1 7. The system according to Claim 1 further comprising any number of additional switchable
2 elements.
- 1 8. The system according to Claim 1 wherein a portion of the switchable elements include
2 electro-optic lenses.
- 3 9. The system according to Claim 1 wherein a portion of the switchable elements include
4 liquid crystal and polymer lenses.
- 1 10. The system of claim 1 wherein the digital focus lens system is a digital telescope,
2 telephoto lens, or zoom lens.
- 1 11. The system of claim 1 wherein the digital focus lens system is a digital camera.
- 1 12. The system of claim 1 wherein the digital focus lens system is a digital projector.
- 1 13. The system of claim 1 wherein the digital focus lens system is a digital microscope.
- 2 14. The system of claim 1 further comprising a controller for providing control signals that
3 serve to activate the first and second switchable elements.
- 1 15. The system according to Claim 1 wherein a portion of the switchable elements may be
2 continuously tuned between the focal powers of their respective first- and second- states.
3
- 4 16. The system of claim 1 further comprising one or more light sources for providing light to
5 be transmitted through and modified by the system.
- 6 17. The system of claim 16 wherein the light is received and transmitted by the first and
7 second switchable elements and is modified in accordance with the selected focal powers
8 of the first and second switchable elements.
- 1 18. The system of claim 17 wherein a portion of the light transmitted by the system forms one
2 or more images.

- 1 19. A method for fabricating a switchable element, comprising:
2 providing a structure having a conductive layer disposed between a substrate and a lens
3 function layer;
4 providing a die substrate with a spatially varying thickness pattern;
5 while the lens function layer is in a soft or viscous state, bringing the die surface into
6 contact with the lens function layer;
7 hardening the lens function layer; and
- 1 20. The method of claim 19, further comprising attaching a second lens function layer to a
2 surface of the substrate and, while the second lens function layer is in a soft or viscous
3 state, bringing a die surface with a varying thickness pattern into contact with the second
4 lens function layer, hardening the second lens function layer and separating the die
5 surface from the second lens function layer.
- 1 21. A method for controlling a digital lens system having N switchable elements in optical
2 communication with each other such that each of them may contribute to a cumulative
3 focal power, where N is 1 or more, wherein each switchable element is capable of being
4 switched between a first-state and a second-state, the method comprising:
5 generating a control signal containing information for controlling the states of each of the
6 N switchable elements; and
7 coupling the control signal to the N switchable elements to set the state of each of the N
8 switchable elements,
9 and wherein a portion of the control signal includes a data stream comprising a control
10 word.
- 1 22. The method of claim 21 wherein the control word is a digital word having a bit field
2 length of N bits.
- 1 23. The method of claim 19 wherein the control signal is an electrical signal.
- 1 24. The method of claim 23 wherein the control signal is at a voltage, current or frequency
2 appropriate for activating the switchable elements to their desired states.
- 1 25. The system of claim 1 wherein one or more of the first and second switchable elements is
2 made by:

3 providing a structure having a conductive layer disposed between a substrate and a lens
4 function layer;
5 providing a die substrate with a spatially varying thickness pattern;
6 while the lens function layer is in a soft or viscous state, bringing the die surface into
7 contact with the lens function layer; and
8 hardening the lens function layer.

1 26. The system of claim 25 wherein fabrication of one or more of the first and second
2 switchable elements further includes:
3 attaching a second lens function layer to a surface of the substrate and, while the second
4 lens function layer is in a soft or viscous state, bringing a die surface with a varying
5 thickness pattern into contact with the second lens function layer, hardening the second
6 lens function layer and separating the die surface from the second lens function layer.

1 27. The system of claim 1 wherein one or more of the first and second switchable elements
2 has a focal power that is continuously tunable.

1 28. The system of claim 1 wherein one or more of the first and second switchable elements
2 includes a fluid.

1/9

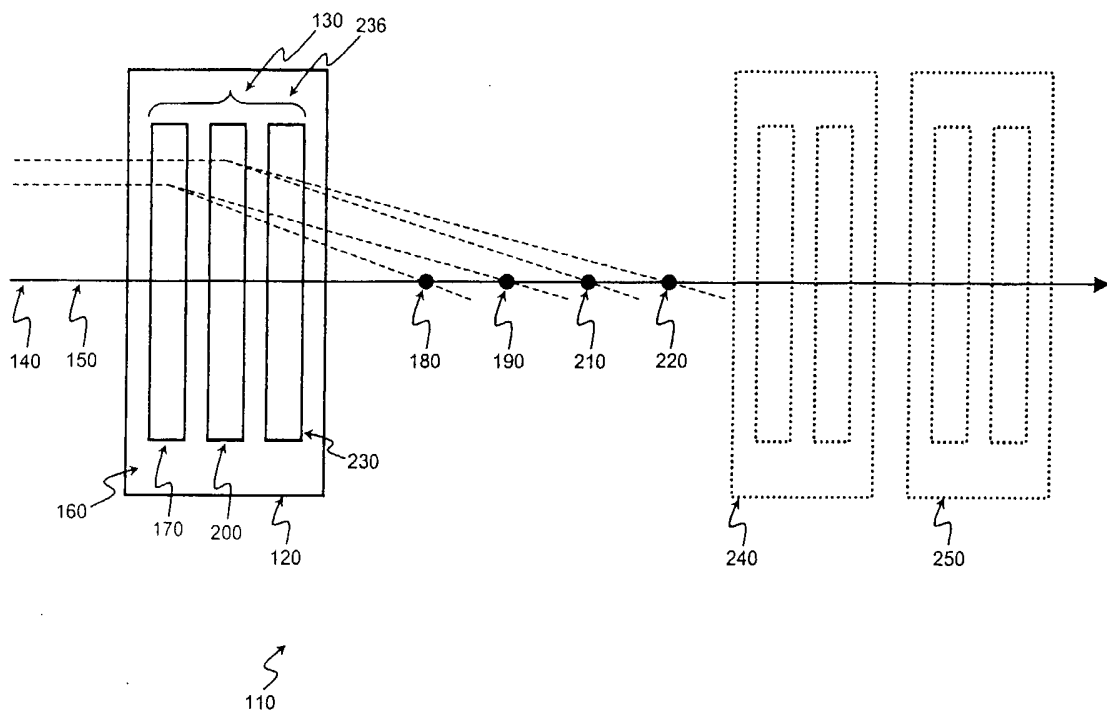

Fig. 1

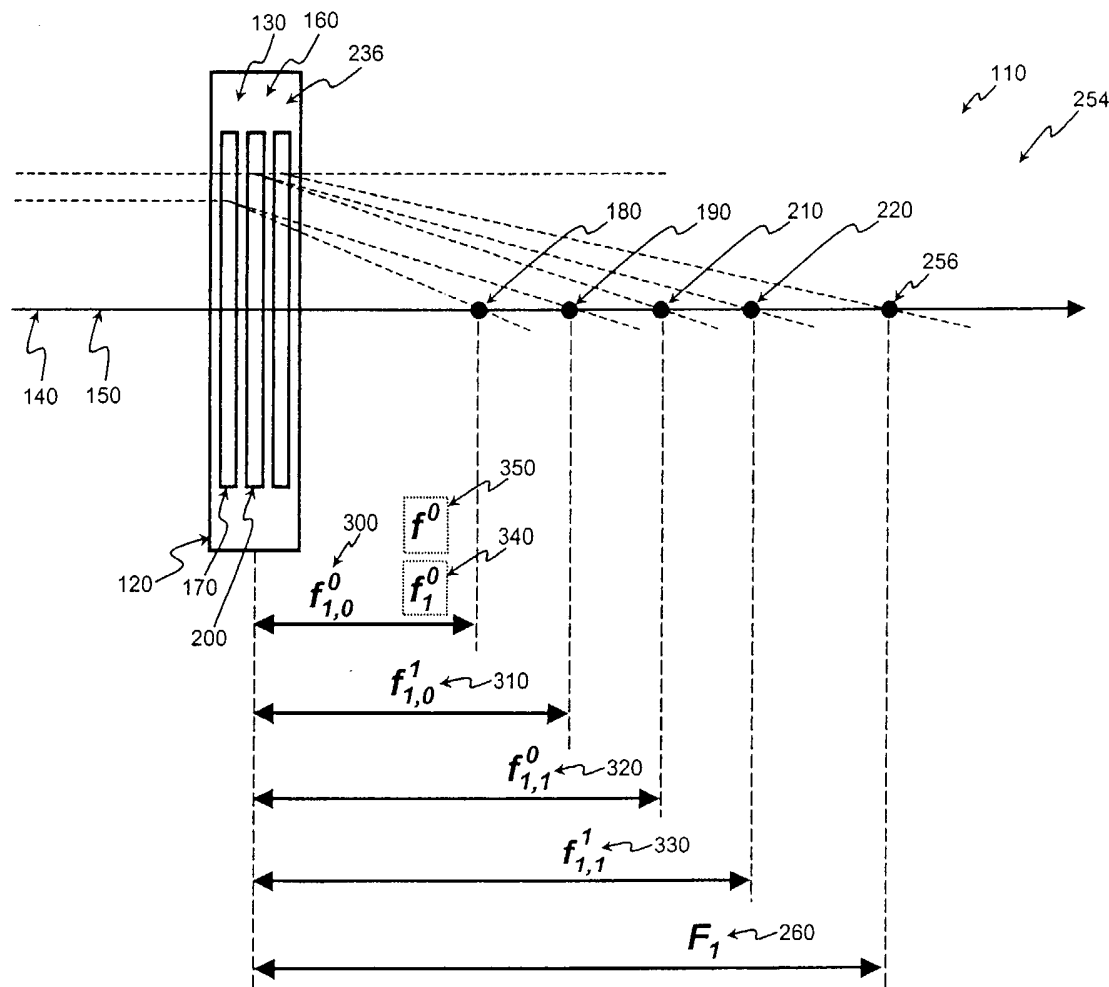

Fig. 2

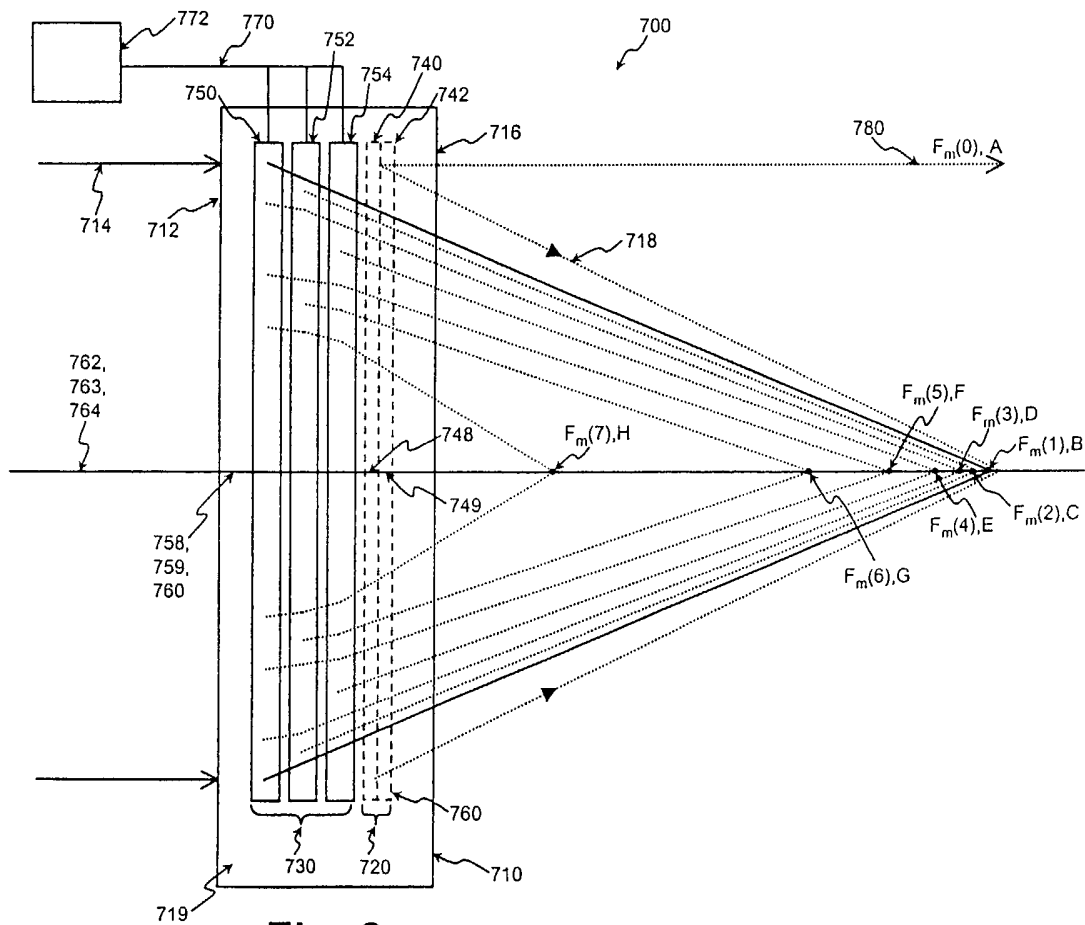

Fig. 3

4/9

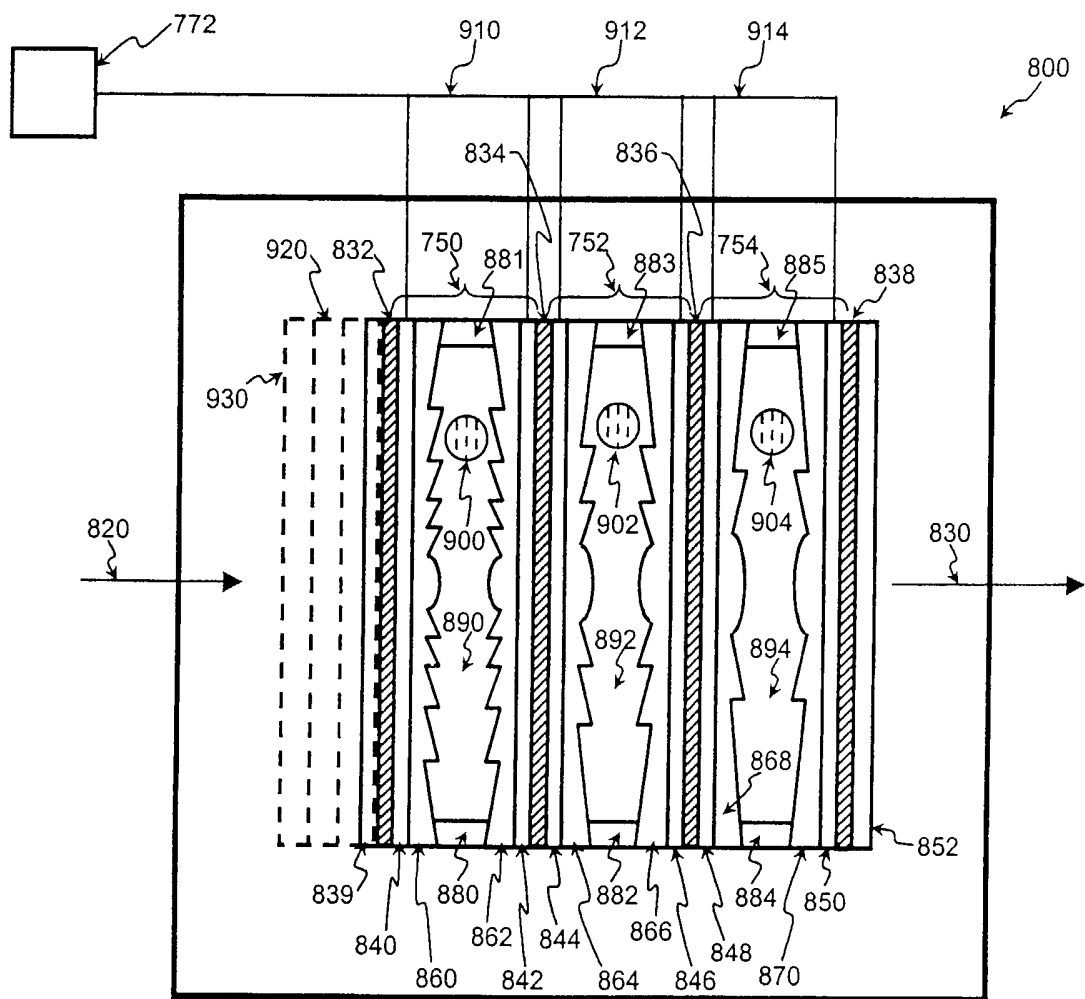

Fig. 4

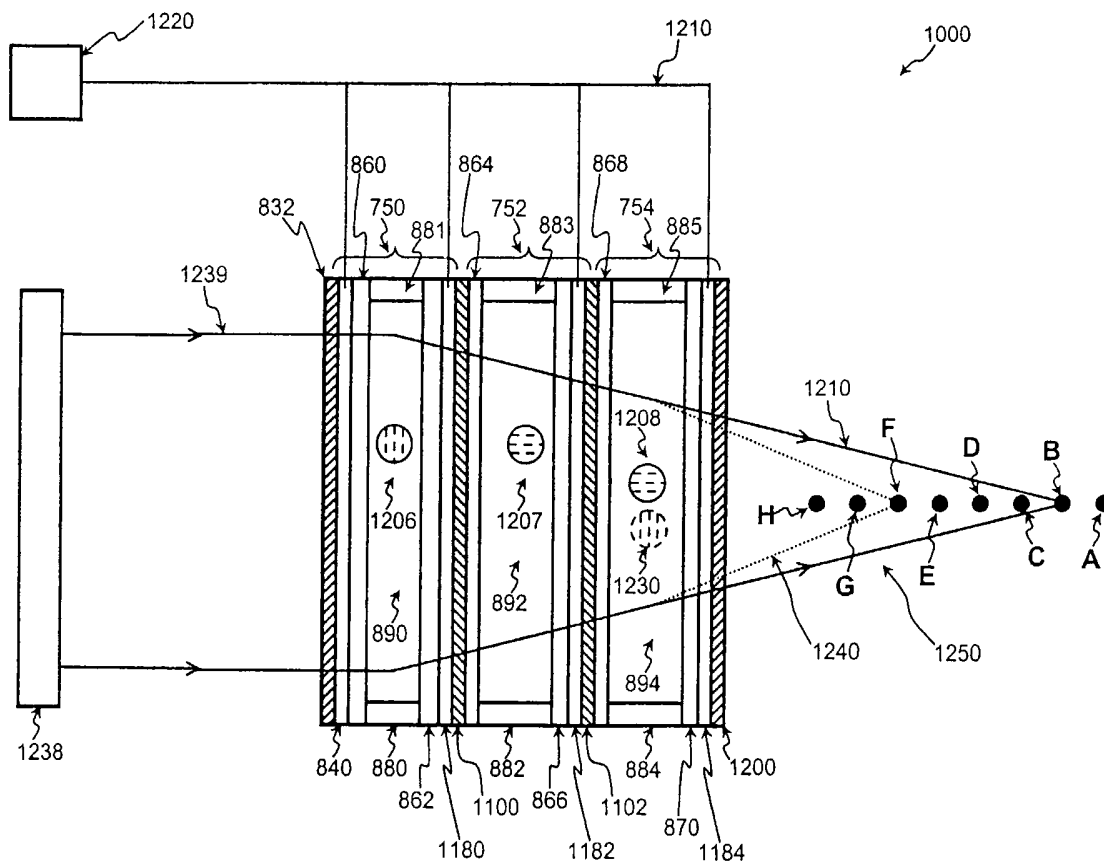

Fig. 5

6/9

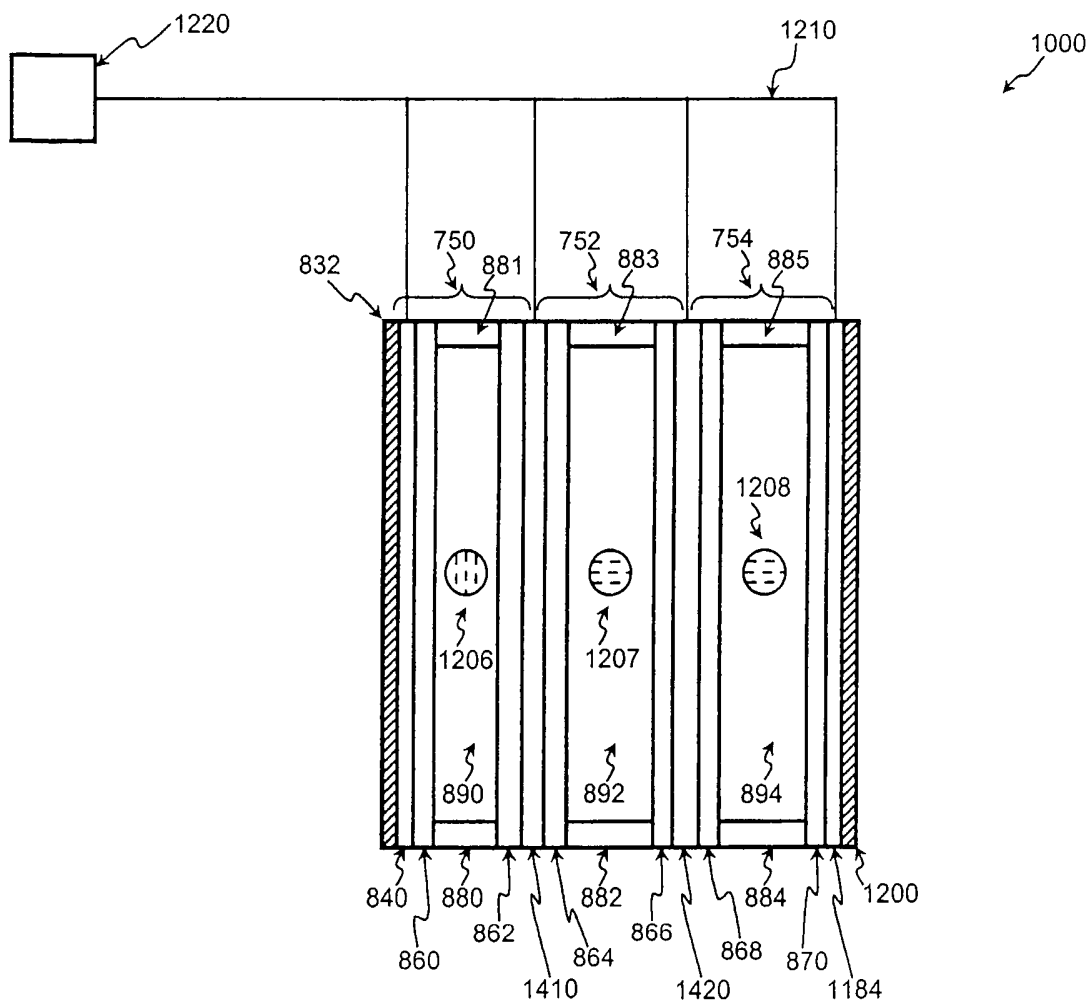

Fig. 6

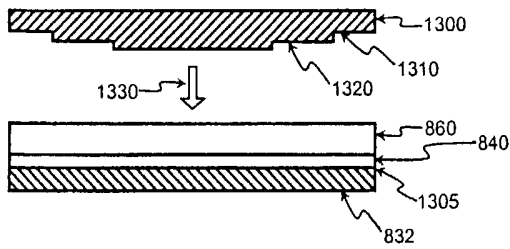

Fig. 7a

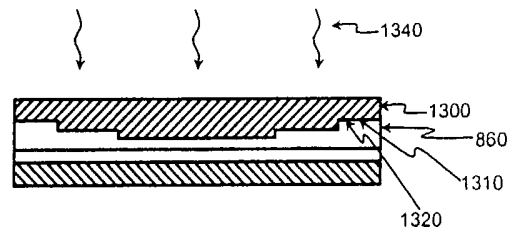

Fig. 7b

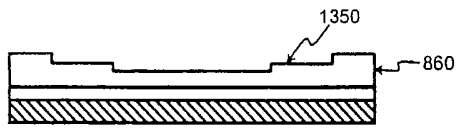

Fig. 7c

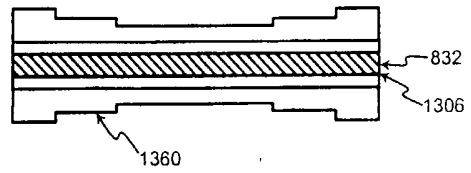

Fig. 7d

8/9

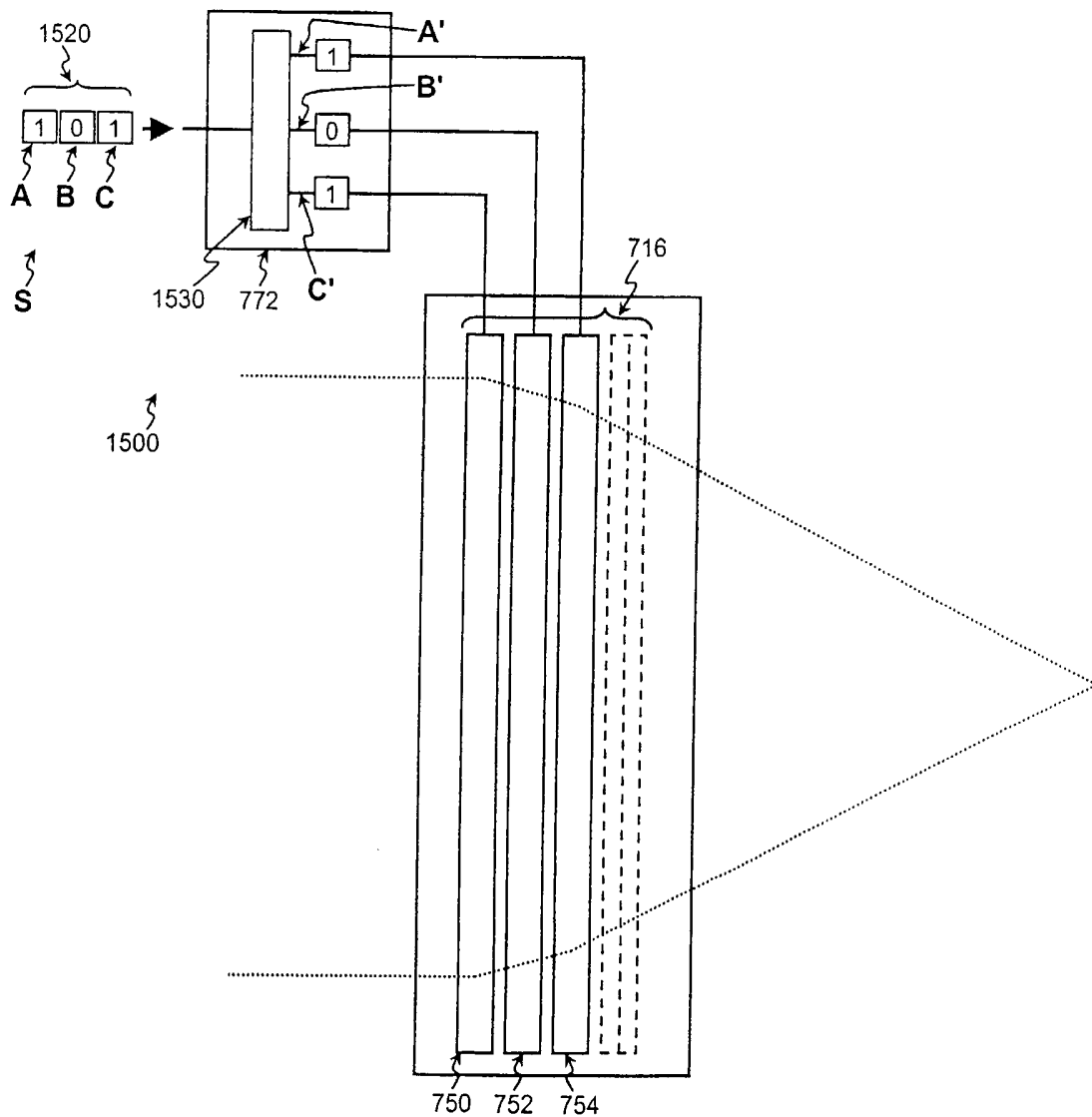

Fig. 8

