

H. H. Smith,
Governor Valve.

N^o 14,020.

Patented Apr. 8, 1856.

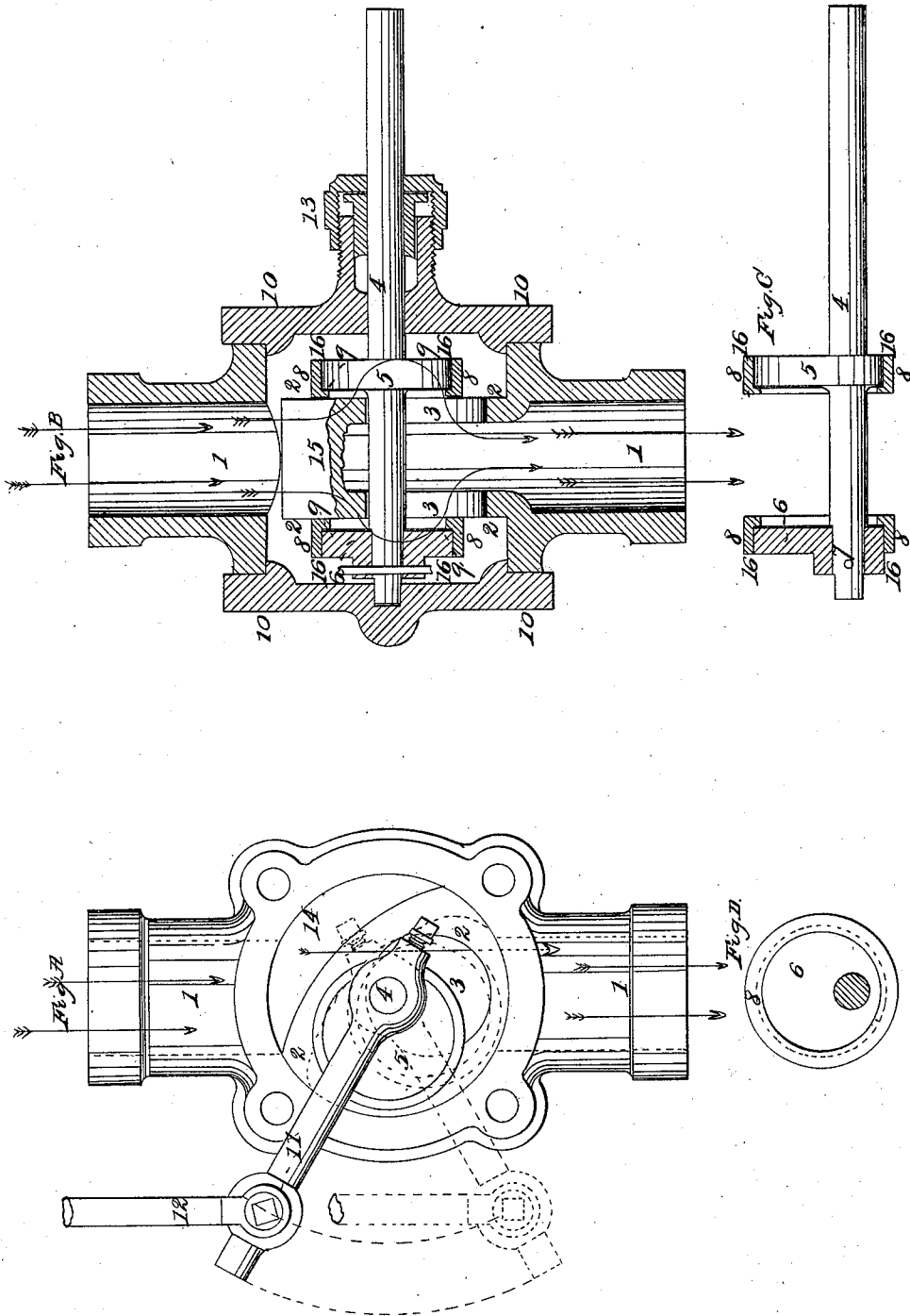

UNITED STATES PATENT OFFICE.

H. H. SMITH, OF CINCINNATI, OHIO.

GOVERNOR-VALVE FOR STEAM-ENGINES.

Specification of Letters Patent No. 14,620, dated April 8, 1856.

To all whom it may concern:

Be it known that I, H. H. SMITH, of the city of Cincinnati, in the county of Hamilton and State of Ohio, have invented a new and useful Improvement in Balance Governor-Valves; and I do hereby declare that the following is a full and exact description thereof, reference being made to the accompanying drawings, forming part of this specification, and to the figures of reference marked thereon.

Similar figures refer to corresponding parts.

The nature of the improvement consists in furnishing the stem of the valve with two rings which are fitted to eccentrics on the stem, and made to slip on said eccentrics so as to adjust themselves to the seat of the valve by the steam pressing against the outside edges of the ring, thereby keeping them up against the valve-seat at all times and forming a steam joint, without being subject to enough friction to affect the action of the governor upon the valve for regulating the proper quantity of steam admitted to the engine.

To enable others skilled in the art to make and use my improvement, I will proceed to describe its construction and operation by referring direct to the accompanying drawings.

Figure A, represents an elevation of the pipe, containing the improved valve, with the cap removed to show its operation. Fig. B, is a sectional elevation of the pipe representing a longitudinal view of the valve. Fig. C, is a longitudinal view of the valve, drawn separate. Fig. D, is a sectional view of the same.

1, 1, represents the pipe provided with the improved valve, and through which pipe the steam passes as denoted by the darts. The steam, in its passage, strikes the diaphragm 15, and descends in the opening 14, Fig. A, formed by the diaphragm and pipe, and then descends through the valve opening 3, 3, as indicated by the darts in Fig. B, and out of the lower end of the pipe direct to the engine.

10, 10, are caps on each side of the pipe, and held to their place by means of bolts or otherwise, and the stem 4 carrying the valves works in the caps 10 as represented in Fig. B, one end working in the stuffing

box 13, and the other end in a recess made in the opposite cap.

5 and 6 are eccentrics cast or otherwise attached to the stem 4. In practice, one eccentric 5 can be cast to the stem and the eccentric 6 fitted on and secured by a pin 7, for the purpose of being able to get the valve-stem through the openings 3, and fitting the rings 8, on the eccentrics, which require fitting from the inside of the eccentrics.

2, 2, represent the face of the valve, properly speaking, provided with the openings 3, 3, and against which faces the inside of the rings 8, on the eccentric, work, and as the governor operates on the valve, through the medium of arm 11, and rod 12, it turns the eccentrics over the openings 3, 3, and thereby cuts off or regulates the proper quantity of steam admitted to the engine. The rings 8 being fitted steam-tight on the circumference of the eccentrics, yet left free to slip against the faces of the valve, are consequently held against the face by the pressure of the steam on the outer edges of the rings at 16. The rings are allowed a little longitudinal play on the eccentrics when placed in the pipe ready for operation, to prevent clamping and to be forced fair against all parts of the valve seats 2, 2, when they are not over the openings 3, 3. The inside of the rings are provided with small flanges 9, 9, as represented in the different drawings, to prevent them from slipping off of the eccentrics, and holds them true, it also prevents their tightening on the eccentrics.

The present plan of valves and openings are round or circular, but I do not confine myself to this form; the valve openings can and will be made of a different form. A circular form will always be best for the valve, as it is the cheapest to fit up.

What I claim as my improvement, and desire to secure by Letters Patent, are—

The self-adjusting rings 8, combined with the eccentrics 5 and 6, or their equivalent, operating substantially as, and for the purposes set forth in the foregoing specifications.

H. H. SMITH.

Witnesses:

MARTIN BENSON,
L. W. SMITH.