

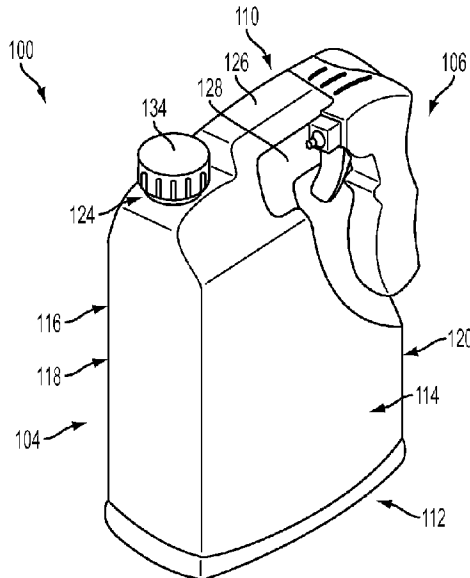

(86) Date de dépôt PCT/PCT Filing Date: 2013/10/14
 (87) Date publication PCT/PCT Publication Date: 2014/04/24
 (45) Date de délivrance/Issue Date: 2021/04/13
 (85) Entrée phase nationale/National Entry: 2015/04/08
 (86) N° demande PCT/PCT Application No.: US 2013/064815
 (87) N° publication PCT/PCT Publication No.: 2014/062560
 (30) Priorités/Priorities: 2012/10/15 (US61/714,018);
 2013/06/27 (US61/840,266)

(51) Cl.Int./Int.Cl. *B05B 11/00* (2006.01),
A01G 25/14 (2006.01), *A01M 7/00* (2006.01),
B05B 15/00 (2018.01)
 (72) Inventeur/Inventor:
 VOELKER, SCOTT C., US
 (73) Propriétaire/Owner:
 MONSANTO TECHNOLOGY LLC, US
 (74) Agent: OSLER, HOSKIN & HARCOURT LLP

(54) Titre : ENSEMBLES DE DISTRIBUTION ET PROCÉDES ASSOCIÉS
 (54) Title: DISPENSING ASSEMBLIES AND RELATED METHODS



(57) **Abrégé/Abstract:**

A dispensing assembly (100) for dispensing fluid generally includes a container (104) having a handle (126) located toward an upper portion of the container (104), and a sprayer (106) having an arm extending away from the sprayer. The arm (142) of the sprayer (106) defines a channel (158) configured to receive at least part of the handle (126) of the container (104) within the channel (158) to thereby couple the sprayer (106) to the container (104). Such a dispensing assembly (100) can be made by forming the container (104) with a handle (104) located toward an upper portion of the container (104), and forming the sprayer (106) with the arm (142) such that the arm (142) can be used to couple the sprayer (106) to the handle (126) of the container (104), where the arm (142) extends away from the sprayer (16) and defines the channel (158) for receiving at least part of the handle (126) of the container (104) into the channel (158).

(12) INTERNATIONAL APPLICATION PUBLISHED UNDER THE PATENT COOPERATION TREATY (PCT)

(19) World Intellectual Property
Organization
International Bureau(10) International Publication Number
WO 2014/062560 A1(43) International Publication Date
24 April 2014 (24.04.2014)

- (51) **International Patent Classification:**
B05B 11/00 (2006.01) **A01M 7/00** (2006.01)
B05B 15/06 (2006.01) **A01G 25/14** (2006.01)
- (21) **International Application Number:** PCT/US2013/064815
- (22) **International Filing Date:** 14 October 2013 (14.10.2013)
- (25) **Filing Language:** English
- (26) **Publication Language:** English
- (30) **Priority Data:**
61/714,018 15 October 2012 (15.10.2012) US
61/840,266 27 June 2013 (27.06.2013) US
- (71) **Applicant:** **MONSANTO TECHNOLOGY LLC**
[US/US]; 800 North Lindbergh Blvd., St. Louis, Missouri
63167 (US).
- (72) **Inventor:** **VOELKER, Scott C.**; 800 North Lindbergh
Blvd., St. Louis, Missouri 63167 (US).
- (74) **Agent:** **PANKA, Brian G.**; Harness, Dickey & Pierce,
P.L.C., 7700 Bonhomme Avenue, Suite 400, St. Louis,
Missouri 63167 (US).
- (81) **Designated States** (*unless otherwise indicated, for every kind of national protection available*): AE, AG, AL, AM, AO, AT, AU, AZ, BA, BB, BG, BH, BN, BR, BW, BY, BZ, CA, CH, CL, CN, CO, CR, CU, CZ, DE, DK, DM, DO, DZ, EC, EE, EG, ES, FI, GB, GD, GE, GH, GM, GT, HN, HR, HU, ID, IL, IN, IR, IS, JP, KE, KG, KN, KP, KR, KZ, LA, LC, LK, LR, LS, LT, LU, LY, MA, MD, ME, MG, MK, MN, MW, MX, MY, MZ, NA, NG, NI, NO, NZ, OM, PA, PE, PG, PH, PL, PT, QA, RO, RS, RU, RW, SA, SC, SD, SE, SG, SK, SL, SM, ST, SV, SY, TH, TJ, TM, TN, TR, TT, TZ, UA, UG, US, UZ, VC, VN, ZA, ZM, ZW.
- (84) **Designated States** (*unless otherwise indicated, for every kind of regional protection available*): ARIPO (BW, GH, GM, KE, LR, LS, MW, MZ, NA, RW, SD, SL, SZ, TZ, UG, ZM, ZW), Eurasian (AM, AZ, BY, KG, KZ, RU, TJ, TM), European (AL, AT, BE, BG, CH, CY, CZ, DE, DK, EE, ES, FI, FR, GB, GR, HR, HU, IE, IS, IT, LT, LU, LV,

[Continued on next page]

(54) **Title:** DISPENSING ASSEMBLIES AND RELATED METHODS

FIG. 1

(57) **Abstract:** A dispensing assembly (100) for dispensing fluid generally includes a container (104) having a handle (126) located toward an upper portion of the container (104), and a sprayer (106) having an arm extending away from the sprayer. The arm (142) of the sprayer (106) defines a channel (158) configured to receive at least part of the handle (126) of the container (104) within the channel (158) to thereby couple the sprayer (106) to the container (104). Such a dispensing assembly (100) can be made by forming the container (104) with a handle (104) located toward an upper portion of the container (104), and forming the sprayer (106) with the arm (142) such that the arm (142) can be used to couple the sprayer (106) to the handle (126) of the container (104), where the arm (142) extends away from the sprayer (16) and defines the channel (158) for receiving at least part of the handle (126) of the container (104) into the channel (158).

WO 2014/062560 A1 

MC, MK, MT, NL, NO, PL, PT, RO, RS, SE, SI, SK,
SM, TR), OAPI (BF, BJ, CF, CG, CI, CM, GA, GN, GQ,
GW, KM, ML, MR, NE, SN, TD, TG).

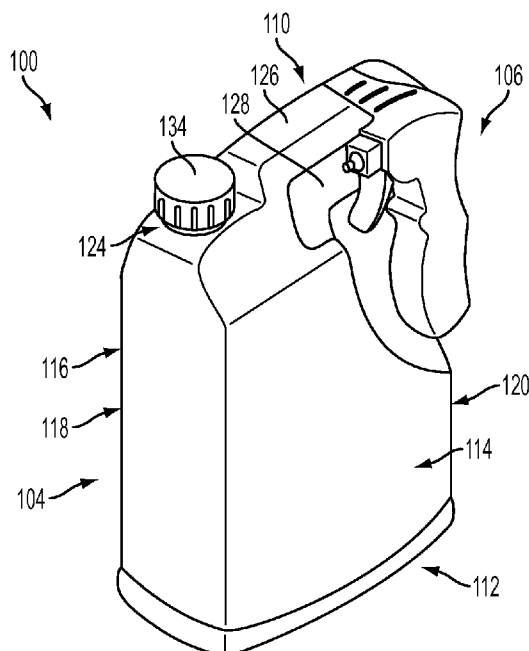
— *before the expiration of the time limit for amending the
claims and to be republished in the event of receipt of
amendments (Rule 48.2(h))*

Published:

— *with international search report (Art. 21(3))*

DISPENSING ASSEMBLIES AND RELATED METHODS

Field

[0002] The present disclosure generally relates to dispensing assemblies, and to methods of making and using such dispensing assemblies.

Background

[0003] This section provides background information related to the present disclosure which is not necessarily prior art.

[0004] Fluids such as pesticides and herbicides are often used in and around homes, lawns and gardens to kill undesirable insects, etc. Typically, the fluids are provided in bottles. And, sprayers are coupled to the bottles by tubing for applying the fluids to desired targets.

Summary

[0005] This section provides a general summary of the disclosure, and is not a comprehensive disclosure of its full scope or all of its features.

[0006] Example embodiments of the present disclosure generally relate to dispensing assemblies for dispensing fluids. In one example embodiment, such a dispensing assembly generally includes a container having a handle located toward an upper portion of the container, and a sprayer having an arm extending away from an upper surface of the sprayer. The arm defines a channel configured to receive at least part of the handle of the container within the channel to thereby couple the sprayer to the container.

[0006a] In accordance with one embodiment of the present invention, there is provided a dispensing assembly for dispensing fluid at desired targets. The dispensing assembly comprises a container having a handle; and a sprayer having an arm extending away from the sprayer. The arm defines a channel configured to receive at least part of the handle of the container within the channel to thereby couple the sprayer to the container. When the sprayer is coupled to the container, the arm of the sprayer extends at least partly around the handle of the container and a lip of the arm engages the handle.

[0006b] A further embodiment of the present invention provides a method of making a dispensing assembly suitable for use to dispense fluid at desired targets. The method comprises: forming a container having a forward wall defining a recess, and having a handle located toward an upper portion of the container; and forming a sprayer having an arm for coupling the sprayer to the handle of the container. The arm extends away from the sprayer and defines a channel configured to receive at least part of the handle of the container into the channel to thereby couple the sprayer to the handle of the container. When the sprayer is coupled to the container, the recess of the container is configured to receive the sprayer so that the sprayer is disposed within a footprint of the container.

[0006c] A further still embodiment provides a dispensing assembly for dispensing fluid at desired targets. The dispensing assembly comprises: a container having an upper portion; and a sprayer having an arm extending away from the sprayer, the arm configured to couple to the container such that an upper surface of the sprayer is substantially coplanar with the upper portion of the container. When the sprayer is coupled to the container, the sprayer is disposed within a footprint defined by a bottom portion of the container. The container includes a handle located toward the upper portion of the container. The arm of the sprayer includes a channel configured to receive at least part of the handle of the container within the channel to thereby couple the sprayer to the container.

[0006d] Yet a further embodiment provides a dispensing assembly for dispensing fluid at desired targets where the dispensing assembly comprises: a container for holding fluid; a handle associated with the container, the handle defining an opening between the container and the handle; and a sprayer for dispensing the fluid from the container. The sprayer has an arm extending away from the sprayer for use in releasably coupling the sprayer to the container, at least part of the arm is configured to extend into the opening defined between the handle and the container when the sprayer is coupled to the container. The arm of the sprayer defines a channel configured to receive at least part of the handle within the channel when the sprayer is coupled to the container.

[0007] In another example embodiment, a dispensing assembly generally includes a container having an upper portion, and a sprayer having an arm extending away from the

sprayer. The arm of the sprayer is configured to couple to the container such that an upper surface of the sprayer is generally coplanar with the upper portion of the container.

[0008] Example embodiments of the present disclosure also generally relate to methods of making dispensing assemblies suitable for use in dispensing fluids. In one example embodiment, such a method generally includes forming a container having a handle located toward an upper portion of the container, and forming a sprayer having a clip portion for coupling the sprayer to the handle of the container, where the clip portion extends away from the sprayer and defines a channel configured to receive at least part of the handle of the container into the channel to thereby couple the sprayer to the handle of the container.

[0009] Further areas of applicability will become apparent from the description provided herein. The description and specific examples in this summary are intended for purposes of illustration only and are not intended to limit the scope of the present disclosure.

Drawings

[0010] The drawings described herein are for illustrative purposes only of selected embodiments and not all possible implementations, and are not intended to limit the scope of the present disclosure.

[0011] FIG. 1 is a perspective view of a dispensing assembly according to an example embodiment of the present disclosure;

[0012] FIG. 2 is another perspective view of the dispensing assembly of FIG. 1;

[0013] FIG. 3 is a perspective view of a container of the dispensing assembly of FIG. 1;

[0014] FIG. 4 is a perspective view of the container of FIG. 3;

[0015] FIG. 5 is another perceptive view of the container of FIG. 3;

[0016] FIG. 6 is a top plan view of the container of FIG. 3;

[0017] FIG. 7 is a front elevation view of the container of FIG. 3;

[0018] FIG. 8 is a section view of the container taken in a plane including line 8–8 in FIG. 7;

[0019] FIG. 9 is a section view of the container taken in a plane include line 9–9 in FIG. 7;

[0020] FIG. 10 is a perspective view of a sprayer of the dispensing assembly of FIG. 1;

[0021] FIG. 11 is a perspective view of the sprayer of FIG. 10;

[0022] FIG. 12 is a top plan view of the sprayer of FIG. 10;

[0023] FIG. 13 is a front elevation view of the sprayer of FIG. 10;

[0024] FIG. 14 is a rear elevation view of the sprayer of FIG. 10;

[0025] FIG. 15 is a side elevation view of the sprayer of FIG. 10;

[0026] FIG. 16 is a top plan view of the dispensing assembly of FIG. 1;

[0027] FIG. 17 is a side elevation view of the dispensing assembly of FIG. 1;

[0028] FIG. 18 is a front elevation view of the dispensing assembly of FIG. 1;

[0029] FIG. 19 is a section view of the dispensing assembly taken in a plane including line 19–19 in FIG. 18;

[0030] FIG. 20 is a section view of the dispensing assembly taken in a plane including line 20–20 in FIG. 18;

[0031] FIG. 21 is a perspective view of a dispensing assembly according to another example embodiment of the present disclosure;

[0032] FIG. 22 is a side elevation view of a sprayer of the dispensing assembly of FIG. 21;

[0033] FIG. 23 is a perspective view of a dispensing assembly according to another example embodiment of the present disclosure;

[0034] FIG. 24 is a rear elevation view of a sprayer of the dispensing assembly of FIG. 23;

[0035] FIG. 25 is a side elevation view of the sprayer of the dispensing assembly of FIG. 23;

[0036] FIG. 26 is a perspective view of an arm of the sprayer of the dispensing assembly of FIG. 23;

[0037] FIG. 27 is a perspective view of a dispensing assembly according to another example embodiment of the present disclosure;

[0038] FIG. 28 is a rear elevation view of a sprayer of the dispensing assembly of FIG. 27;

[0039] FIG. 29 is a side elevation view of the sprayer of the dispensing assembly of FIG. 27;

[0040] FIG. 30 is a perspective view of an arm of the sprayer of the dispensing assembly of FIG. 27;

[0041] FIG. 31 is a perspective view of a dispensing assembly according to another example embodiment of the present disclosure;

[0042] FIG. 32 is a side elevation view of a sprayer of the dispensing assembly of FIG. 31;

[0043] FIG. 33 is a perspective view of a dispensing assembly according to another example embodiment of the present disclosure;

[0044] FIG. 34 is a side elevation view of a sprayer of the dispensing assembly of FIG. 33 with an arm of the sprayer shown folded generally downwardly; and

[0045] FIG. 35 is a side elevation view of the sprayer of the dispensing assembly of FIG. 33 with the arm of the sprayer shown folded generally upwardly for use in coupling the sprayer to the container.

[0046] Corresponding reference numerals indicate corresponding parts throughout the several views of the drawings.

Detailed Description

[0047] Example embodiments of the present disclosure generally relate to dispensing assemblies, and to methods of making and using such dispensing assemblies. The dispensing assemblies can be used to dispense fluids (e.g., desired liquid formulations, etc.) at desired locations and to apply the fluids at desired targets such as, for example, unwanted pests, plants, etc.

[0048] The dispensing assemblies of the present disclosure generally include containers for holding the fluids, and sprayers for dispensing the fluids from the containers. Various sizes of containers may be used. And, various types of sprayers may be used (e.g., pump-type sprayers, piston-operated sprayers, powered sprayers (e.g., battery-powered sprayers, etc.), etc.).

[0049] In some aspects of the present disclosure, the sprayers are configured to couple to the containers, for example, for use in packaging the dispensing assemblies, shipping the dispensing assemblies, storing the dispensing assemblies, etc.

[0050] In some aspects of the present disclosure, the sprayers are configured to at least partly nest with the containers when coupled thereto. For example, walls of the containers may define recesses configured to receive (and allow for nesting of) the sprayers within the recesses when the sprayers are coupled to the containers. In one example embodiment, a front wall of a container defines a recess configured to receive a sprayer when the sprayer is coupled to the container (such that the sprayer nests generally within the front wall of the container). As part of this nesting feature, upper surfaces, portions, etc. of the sprayers may be disposed generally along, generally coplanar with, generally aligned with, etc. upper surfaces, portions, etc. of the containers when the sprayers are coupled to the containers. In addition, end (e.g., rearward end, forward end, etc.) surfaces, portions, etc. of the sprayers may be disposed generally along, generally coplanar with, generally aligned with, etc. end (e.g., rearward end, forward end, etc.) surfaces, portions, etc. of the containers when the sprayers are coupled to the containers. And further, the sprayers and the containers may be disposed within footprints of the containers and/or within perimeters defined by the containers when the sprayers are coupled to the containers.

[0051] In some aspects of the present disclosure, the sprayers may have clip portions configured to engage (e.g., resiliently engage, frictionally engage, engage based on gravity, etc.) the containers (e.g., handle portions of the containers, other portions of the containers, etc.) for coupling the sprayers to the containers. The clip portions may have shapes (e.g., L-shapes, shapes with lips, arcuate shapes, shapes with tabs, shapes configured to mate with the containers, etc.) configured to engage the containers.

[0052] In some aspects of the present disclosure, clip portions of the sprayers may include arms extending away from the sprayers and defining channels configured to receive at least part of the containers within the channels to couple the sprayers to the containers. The arms may extend at least partly around portions (e.g., handle portions, other portions, etc.) of the containers to thereby couple the sprayers to the containers. The arms may be monolithically formed with the sprayers, or the arms may be formed separately from the sprayers and attached thereto (e.g., welded to the sprayers, staked to the sprayers, frictionally coupled to the sprayers,

releasably coupled to the sprayers, pivotally coupled to the sprayers, etc.). Further, in some aspects of the present disclosure, the containers may include grooves configured to receive at least part of the arms of the sprayers into the grooves when the sprayers are coupled to containers.

[0053] In some aspects of the present disclosure, the containers may have handles located toward upper portions of the containers, and the arms of the sprayers may have shapes (e.g., L-shapes, shapes with lips, rounded shapes, etc.) configured to extend at least partly around the handles of the containers to thereby couple the sprayers to the containers. Further, in some aspects, the handles of the containers may include grooves configured to receive at least part of the arms of the sprayers into the grooves when the sprayers are coupled to containers.

[0054] In some aspects of the present disclosure, the containers may not include handles located toward upper portions of the containers. Here, the clip portions of the sprayers may be configured to engage (e.g., resiliently snap-fit to, etc.) other portions of the containers for coupling the sprayers to the containers. For example, the containers may be formed with other structure configured to receive the clip portions. And, the sprayers can thus be coupled to the containers such that upper portions of the sprayers are generally coplanar, aligned, etc. with upper portions of the containers. In addition, the sprayers may also be disposed within footprints of the containers and/or within perimeters defined by the containers when the sprayers are coupled to the containers.

[0055] Example embodiments will now be described more fully with reference to the accompanying drawings.

[0056] FIGS. 1-20 illustrate an example embodiment of a dispensing assembly 100 according to the present disclosure. The dispensing assembly 100 can be used in applications such as, for example, pest control, weed control, etc. In connection with such applications, the dispensing assembly 100 can be used in settings such as residential settings, commercial settings, etc. in and around homes, businesses, lawns, gardens, etc. And, any desired fluid may be used (e.g., dispensed, etc.) in connection with the dispensing assembly 100 including, for example, pesticides, herbicides, other liquid formulations, etc.

[0057] As shown in FIGS. 1 and 2, the dispensing assembly 100 generally includes a container 104 and a sprayer 106. The container 104 is configured to hold fluid for use in the desired application of the dispensing assembly 100. And, the sprayer 106 is configured to draw

fluid out of the container 104 for dispensing, applying, etc. the fluid at desired targets (e.g., unwanted insects, plants, etc.) associated with the application of the dispensing assembly 100.

[0058] The sprayer 106 of the illustrated dispensing assembly 100 can be selectively coupled to and uncoupled, removed, etc. from the container 104. For example, the sprayer 106 can be coupled (e.g., resiliently snap-fit, etc.) to the container 104 for commercial presentation (e.g., at the point of sale of the dispensing assembly 100, etc.), for storage, for transport, etc. of the dispensing assembly 100. Then, the sprayer 106 can be uncoupled from the container 104 when desired to dispense the fluid from the container 104 (via the sprayer 106). And, the sprayer 106 can then be recoupled (e.g., resiliently snap-fit, etc.) to the container 104 again for storage, transport, etc. This will be described in more detail hereinafter.

[0059] As shown in FIGS. 3-9, the container 104 of the illustrated dispensing assembly 100 includes an upper portion 110, a lower portion 112, generally opposing forward and rearward walls 114, 116, and generally opposing side walls 118, 120. The upper portion 110, the lower portion 112, and the walls 114, 116, 118, 120 define a volume within the container 104 for holding fluid. The container 104 can have any desired volume within the scope of the present disclosure, for example (and without limitation), a one-half gallon volume, a one gallon volume, etc. What's more, the container 104 can be formed from any suitable materials (e.g., plastics, polymeric resinous material such as high density polyethylene (HDPE), composite materials, etc.) and/or by any suitable processes (e.g., molding processes, etc.) within the scope of the present disclosure.

[0060] The upper portion 110 of the container 104 includes a spout 124 (broadly, an opening) and a handle 126. The spout 124 is in fluidic communication with the container 104 and is configured for receiving fluid into the container 104 and/or for use in dispensing fluid from the container 104. The handle 126 is configured for use in carrying the container 104 (and sprayer 106). The handle 126 extends generally horizontally along the upper portion 110 of the container 104, generally between the side wall 120 and the spout 124. An opening 128 is defined generally between the handle 126 and an upper surface of the container 104. The opening 128 is oriented such that, when a user grasps the handle 126, the user's hand and/or fingers can extend into the opening 128 and, if desired, around the handle 126. A groove 130 is provided around at least part of the handle 126 for use in coupling the sprayer 106 to the container 104 (as will be described in more detail hereinafter).

[0061] The container 104 also includes a cap 134 (broadly, a cover) removably coupled to the spout 124. The cap 134 allows for selectively covering and uncovering the spout 124 to selectively allow and inhibit access to the fluid in the container 104. In addition, the cap 134 is configured to fluidically couple the sprayer 106 to the container 104 (as will be described in more detail hereinafter). In the illustrated embodiment, the cap 134 is threaded onto the spout 124. However, in other example embodiments, dispensing assemblies may include caps that are coupled to spouts of containers differently, for example, press-fit onto the spouts, snap-fit onto the spouts, friction-fit onto the spouts, coupled to the spouts by fasteners, fixedly coupled to the spouts (e.g., molded as one piece with the spouts, welded to the spouts, coupled to the spouts via adhesives, etc.), etc.

[0062] With reference now to FIGS. 10-15, the sprayer 106 of the illustrated dispensing assembly 100 includes a head portion 106a, a handle portion 106b, and an actuator 138 (e.g., a trigger, etc.). The head portion 106a and the handle portion 106b are arranged in a pistol-style configuration, with the handle portion 106b contoured to receive a hand of a user and the actuator 138 located adjacent the handle portion 106b to receive a finger of the user's hand. As such, in use, a user can with one hand grasp the handle portion 106b of the sprayer 106 and position a finger on the actuator 138 for dispensing fluid from the container 104, and then with the other hand carry the container 104 via the handle 126. The user can then move the actuator 138 (e.g., pull the actuator 138 toward the handle portion 106b, pump the actuator 138, etc.) to thereby dispense fluid from the container 104. As such the dispensing assembly 100 can provide a mobile unit for a user to quickly and easily dispense fluid at desired targets. The sprayer 106 can include suitable valves and working mechanisms for dispensing (e.g., for drawing, sucking, etc.) fluid from the container 104 within the scope of the present disclosure. What's more, the sprayer 106 can be formed from any suitable materials (e.g., plastics, polymeric resinous material such as high density polyethylene (HDPE), composite materials, etc.) and/or by any suitable processes (e.g., molding processes, etc.) within the scope of the present disclosure. In other example embodiments, dispensing assemblies may include sprayers having head portions and handle portions arranged in configurations other than pistol-style configurations (e.g., head portions and handle portions arranged in generally linear configurations, etc.).

[0063] The sprayer 106 of the illustrated dispensing assembly 100 also includes a clip portion 106c located adjacent the head portion 106a for use in coupling the sprayer 106 to the

container 104. The clip portion 106c includes an arm 142 extending laterally away from the head portion 106a, and ribs 144 disposed along a side surface of the head portion 106a (generally below the arm 142). The illustrated arm 142 is formed generally continuously with an upper surface of the head portion 106a and defines a generally L-shape. The L-shape arm 142 includes a first portion 142a that is generally coplanar, aligned, etc. with the upper surface of the head portion 106a and a second portion 142b extending generally downwardly from the first portion 142a. A free end of the first portion 142a is generally rounded, curved, etc. to form a lip 146. In the illustrated embodiment, the clip portion 106c is formed as one piece (e.g., monolithically, unitarily, etc.) with the head portion 106a. For example, the clip portion 106c may be molded as one piece with the head portion 106a. In other example embodiments, however, dispensing assemblies may include sprayers with clip portions formed separately from the sprayers and then subsequently attached thereto. In addition, in other example embodiments, dispensing assemblies may include sprayers with clip portions shaped and/or located differently than illustrated herein, but still configured to couple the sprayers to containers of the dispensing assemblies. Also in the illustrated embodiment, the second portion 142b of the arm 142 extends generally downwardly from the first portion 142a at an angle that is greater than about ninety degrees. In other example embodiments, dispensing assemblies may include sprayers with arms having second portions that extend downwardly from first portions at angles other than illustrated herein, for example, about ninety degrees, less than ninety degrees, etc.

[0064] The sprayer 106 of the illustrated assembly 100 further includes tubing 150 configured to fluidically couple the sprayer 106 to the container 104 for transporting fluid from the container 104 to the sprayer 106 (for dispensing). The tubing 150 extends through the handle portion 106b of the sprayer 106 and, at one end portion (not visible), operatively couples to the head portion 106a of the sprayer 106 (e.g., to valves, pumps, etc.) in the sprayer 106. An opposite end portion 150a of the tubing 150 is then configured to selectively couple to the cap 134 of the container 104 (e.g., when desired to dispense fluid from the container 104, etc.). The tubing 150 is generally flexible. And, the flexibility of the tubing 150 permits the sprayer 106 to be moved in any direction relative to the container 104. With that said, the end portion 150a of the tubing 150 can couple to the cap 134 of the container 104 by any suitable operations. For example, as described in U.S. Patent No. 5,469,993, the cap 134 may include a dip tube (not shown)

extending into the container 104 through the spout 124 and a nozzle (e.g., a spout, etc.) (not shown) in fluidic communication with the dip tube. The tubing 150 can then couple (e.g., via a connector on the end portion of the tubing 150, etc.) to the nozzle. The nozzle may then be configured to pivot between an open position in which fluid can be drawn out of the container 104 by the sprayer 106, and a closed position inhibiting such movement of the fluid (the tubing 150 may remain coupled to the nozzle, or the tubing 150 may be uncoupled from the nozzle as desired).

[0065] In the illustrated embodiment, the handle portion 106b of the sprayer 106 is generally hollow. As such, the tubing 150 can be positioned within the handle portion 106b when not in use (e.g., for storage, etc.). When desired to dispense fluid from the container 104 using the sprayer 106, the tubing 150 can then be removed from the handle portion 106b of the sprayer 106 and coupled to the container 104, via the cap 134, for providing fluid from the container 104 to the sprayer 106 through the tubing 150. After such use, the tubing 150 may be uncoupled from the cap 134 of the container 104 and repositioned within the handle portion 106b of the sprayer 106 (if desired). In other example embodiments, dispensing assemblies may include structure separate from sprayers of the dispensing assemblies for use in holding, receiving, storing, etc. tubing (e.g., compartments, containers, etc. formed on, coupled to, etc. containers of the dispensing assemblies).

[0066] FIGS. 16-20 illustrate the dispensing assembly 100 with the sprayer 106 coupled to the container 104. The sprayer 106 is disposed generally along the forward wall 114 of the container 104, generally within a recess 154 defined by the forward wall 114. The head portion 106a of the sprayer 106 is disposed adjacent the opening 128 of the container 104 (e.g., next to the opening 128 of the container 104, at least partly in the opening 128 of the container 104, at the same vertical level as the opening 128 of the container 104, etc.) and toward the side wall 120 of the container 104. The actuator 138 of the sprayer 106 is located generally above the recess 154, and at the same general level as the opening 128 of the container 104. A forward portion of the handle 126 is received within a channel 156 defined by the ribs 144 of the sprayer 106. And, the arm 142 of the sprayer 106 is positioned over the handle 126, generally within the groove 130 of the handle 126, with the handle 126 generally received within a channel 158 defined by the arm 142. In this position, the generally first portion 142a of the arm 142 is disposed along an upper portion of the handle 126, the generally second portion 142b of the arm

142 is disposed along a rearward portion of the handle 126, and the lip 146 of the arm 142 is disposed generally under the handle 126. In the illustrated embodiment, the arm 142 of the sprayer 106 is resiliently flexible to accommodate positioning (and repeated repositioning) of the arm 142 over (and partly around) the handle 126 (e.g., for repeated removal and reattachment of the sprayer 106 to the handle 126 of the container 104, etc.). As such, the sprayer 106 (via the arm 142) is resiliently snap fit onto the handle 126 of the container 104 in the illustrated embodiment. Further, the weight of the sprayer 106 combined with the offset positioning of the arm 142 (together with the snap fit coupling of the sprayer 106 onto the handle 126 of the container 104) may help hold (e.g., via a counterbalance effect, etc.) the sprayer on the container 104. In other example embodiments, dispensing assemblies may include sprayers and containers where the weight of the sprayers combined with offset positioning of arms on the sprayers help hold the sprayers on the containers (e.g., with the arms of the sprayers positioned at least partly over portions of the containers and independent of snap fit couplings of the sprayers onto the containers, etc.).

[0067] To uncouple the sprayer 106 from the container 104, the arm 142 of the sprayer 106 can be biased to release the lip 146 from under the handle 126. The sprayer 106 can then be pivoted off the handle 126 to move the entire arm 142 out of the groove 130 of the handle 126. Alternatively, the sprayer 106 can be initially pivoted away from the forward wall 114 of the container 104 to release the handle 126 from the channel 156 defined by the ribs 144 of the sprayer 106. And, the arm 142 of the sprayer 106 can then be manipulated to release the lip 146 from under the handle 126.

[0068] As previously stated, in other example embodiments, dispensing assemblies may include sprayers with clip portions shaped and/or located differently than illustrated herein. For example, dispensing assemblies may include sprayers having clip portions with arms having shapes other than L-shapes (e.g., C-shapes, etc.), but that are still configured to couple (e.g., snap-fit, etc.) the sprayers to handles of containers of the dispensing assemblies. Also for example, dispensing assemblies may include sprayers having clip portions with arms that define shapes that generally correspond to shapes of handles of containers to which the sprayers are to be releasably coupled.

[0069] In the illustrated embodiment, the clip portion 106c of the sprayer 106 resiliently snap-fits to the handle 126 of the container 104. This allows for quick coupling and

uncoupling of the sprayer 106 to and from the handle 126 of the container 104. In addition, the clip portion 106c provides a generally self-contained attachment means of the sprayer 106 to the container 104. Additional fasteners are not required to couple the sprayer 106 to the container 104. Further, the clip portion 106c securely couples the sprayer 106 to the container 104 against inadvertent removal such that, in preparation for initial shipping and sale of the dispensing assembly 100, additional securing means (e.g., adhesive such as glue and tape, mechanical straps, shrink wrap, etc.) are not required for securing the sprayer 106 to the container 104.

[0070] Also in the illustrated embodiment, the sprayer 106 is coupled to the container 104 generally within a footprint defined by the container 104 (see, e.g., FIG. 15, etc.), and generally within a perimeter defined by the upper portion 110, lower portion 112, and walls 114, 116, 118, 120 of the container 104 (see, e.g., FIGS. 16 and 17, etc.). The recess 154 defined by the forward wall 114 of the container 104 is configured to accommodate and receive substantially the entire sprayer 106 (e.g., the sprayer 106 nests within the recess 154 against the forward wall 114 of the container 104, etc.). As such, a forward side surface of the sprayer 106 is generally flush with a non-recessed surface portion of the forward wall 114. In addition, an upper surface of the head portion 106a and clip portion 106c of the sprayer 106 are generally flush, coplanar, etc. with the upper surface of the handle 126. And, a right side surface (as viewed in FIG. 18) of the sprayer 106 is generally flush with the side wall 120 of the container 104. Thus, the sprayer 106 occupies no additional shelf space or box space than the container 104 would without the sprayer 106, which can allow the dispensing assembly 100 to be compactly boxed, stored, shipped, displayed, etc.

[0071] Also in the illustrated embodiment, the sprayer 106 is coupled to the handle 126 of the container 104 toward the upper portion of the container 104. As such, the recess 154 defined by the forward wall 114 of the container 104 is positioned generally higher on the container 104 which provides more volume within the container 104 below the recess 154 (as compared to other known containers). As a result, the overall depth of the container 104 (extending between the forward wall 114 and rearward wall 116) can be reduced without decreasing a total volume of the container 104. For example, the depth of the container 104 may be reduced by at least about 0.25 inches or more without decreasing the total volume of the container 104. In turn, the footprint of the container 104 can be reduced without decreasing the total volume of the container 104. What's more, the actuator 138 of the sprayer 106 is located

generally above the recess 154, such that the recess can have a generally generic shape without having to specifically accommodate the actuator 138.

[0072] Further in the illustrated embodiment, the sprayer 106 is coupled to the container 104 along the forward wall 114 of the container 104. This positions the sprayer 106 in an immediately visible location to users (e.g., consumers, etc.) considering the dispensing assembly 100. As such, the sprayer 106 (e.g., the type of the sprayer 106, the size of the sprayer 106, etc.) can be readily considered by consumers viewing the dispensing assembly 100 on a shelf at a retail location in deciding to purchase the dispensing assembly 100.

[0073] The dispensing assembly 100 of the illustrated embodiment further provides a ready to use system for dispensing fluid. For example, the dispensing assembly 100 can be provided to a user with a premixed ready to spray liquid formulation in the container 104 and the sprayer 106 coupled to the container 104 ready for use to dispense the liquid formulation from the container 104. The sprayer 106 is simply uncoupled from the container 104, and the tubing 150 then coupled to the cap 134 of the container 104. The actuator 138 of the sprayer 106 can then be moved to draw fluid out of the container 104 for discharge onto desired targets. As such, the dispensing assembly 100 is shelf ready (e.g., ready for retailers to place on shelves for sale to consumers and ready for immediate use by consumers, etc.).

[0074] FIGS. 21 and 22 illustrate another example embodiment of a dispensing assembly 200 according to the present disclosure. The dispensing assembly 200 is substantially similar to the dispensing assembly 100 illustrated in FIGS. 1-20. For example, the dispensing assembly 200 generally includes a container 204 and a sprayer 206. And, the sprayer 206 is configured to couple to the container 204 (in similar fashion to that previously described for the dispensing assembly 100). In this embodiment, however, the sprayer 206 includes separate first and second body portions 206d, 206e, as well as a separate arm 242. The first and second body portions 206d, 206e are coupled (e.g., welded, etc.) together along joint 270, and the arm 242 is coupled (e.g., welded, etc.) to the second body 206e portion along joint 272. As such, in this example embodiment, the arm 242 can be formed separate from the body portions 206d, 206e of the sprayer 206 and subsequently coupled thereto as desired (e.g., when assembling the sprayer 206, when assembling the dispensing assembly 200, etc.). With that said, it should be appreciated that the body portions 206d, 206e of the sprayer 206 and the arm 242 of the sprayer 206 can be formed from any suitable process (e.g., a molding process, etc.).

[0075] FIGS. 23-26 illustrate another example embodiment of a dispensing assembly 300 according to the present disclosure. The dispensing assembly 300 of this embodiment is substantially similar to the dispensing assembly 100 illustrated in FIGS. 1-20. For example, the dispensing assembly generally includes a container 304 and a sprayer 306. And, the sprayer 306 is configured to couple to the container 304 (in similar fashion to that previously described for the dispensing assembly 100). In this embodiment, however, the sprayer 306 includes an arm 342 formed separate from the sprayer 306 and coupled thereto. In particular, the sprayer 306 includes a tab 376 formed along an upper side portion of the sprayer 306, and the arm 342 includes a recess 378. The recess 378 of the arm 342 is configured to fit over the tab 376 of the sprayer 306, such that the arm 342 can be press-fit (e.g., compression fit, resistance fit, friction fit, etc.) onto the sprayer 306. Thus, in this embodiment, the arm 342 can again be formed separate from the sprayer 306 and subsequently coupled thereto as desired (e.g., when assembling the sprayer 306, when assembling the dispensing assembly 300, etc.). It should be appreciated that the sprayer 306 and the arm 342 of the sprayer 306 can be formed from any suitable process (e.g., a molding process, etc.). In some aspects of the present disclosure, the arm 342 may be further secured to the sprayer 306 by additional means (e.g., heat stake, welds (e.g., sonic welds, etc.), adhesive (e.g., glue, etc.), mechanical fasteners, etc.). In these aspects, the tab 376 of the sprayer 306 and the recess 378 of the arm 342 also operate to help align the arm 342 on the sprayer 306 prior to securing the arm 342 to the sprayer 306 via the additional means.

[0076] In other example embodiments, dispensing assemblies may include sprayers similar to the sprayer 306 of the dispensing assembly 300, but where arms of the sprayers include tabs and where the sprayers include recesses configured to receive the tabs of the arms for use in press-fitting the arms onto the sprayers. As such, it should be appreciated that any desired combination and/or any desired number of mating components (e.g., male/female components, etc.) could be used with sprayers and arms for coupling them together within the scope of the present disclosure, for example, tabs, recesses, nubs, openings, notches, flanges, flanges with lips, etc. What's more, the mating components may have any suitable configuration (e.g., horizontal flanges configured to be received in corresponding openings, L-shaped flanges configured to be received in corresponding openings, nubs configured to be received in corresponding openings, pins configured to be received in corresponding openings, protrusions

configured to be received in corresponding recesses, etc.). Still further, the mating components may also operate to help align the arms with the sprayers when coupling them together (with additional means (as described herein) then also used to help secure the arms to the sprayers).

[0077] In one example embodiment, a dispensing assembly includes a sprayer with an arm having a flange extending generally downwardly at an angle (e.g., about ninety degrees, greater than about ninety degrees, less than about ninety degrees, etc.) from the arm. And, the sprayer includes an opening (e.g., in a side surface of the sprayer, etc.) configured to receive (e.g., to hook, etc.) the flange therein (e.g., in a nesting fashion, etc.) for use in coupling the arm to the sprayer. In some aspects, the arm may then be further secured to the sprayer 306 by additional means (e.g., heat stake, welds (e.g., sonic welds, etc.), adhesive (e.g., glue, etc.), mechanical fasteners, etc.).

[0078] In another example embodiment, a dispensing assembly includes a sprayer with an arm having a flange extending generally outwardly from an upper surface of the arm (e.g., such that the flange is generally coplanar with the upper surface of the arm, etc.). And, the sprayer includes a notch opening (e.g., in an upper surface of the sprayer, etc.) configured to receive the flange therein (e.g., in a nesting fashion, etc.) for use in coupling the arm to the sprayer. In some aspects, the arm may then be further secured to the sprayer 306 by additional means (e.g., heat stake, welds (e.g., sonic welds, etc.), adhesive (e.g., glue, etc.), mechanical fasteners, etc.).

[0079] In another example embodiment, a dispensing assembly includes a sprayer with an arm having a flange extending generally away from the arm. And, the sprayer includes an opening (e.g., in a side surface of the sprayer, in an upper surface of the sprayer, etc.) configured to receive the flange therein for use in coupling the arm to the sprayer. The flange of the arm includes protrusions (e.g., dimples, tabs, etc.), and the opening of the sprayer includes corresponding recesses, voids, etc. defined therein for receiving the protrusions to thereby provide a snap-fit coupling between the arm and the sprayer (e.g., a permanent snap-fit coupling, a releasable snap-fit coupling, etc.) when the flange is received in the opening. In some aspects, the arm may then be further secured to the sprayer 306 by additional means (e.g., heat stake, welds (e.g., sonic welds, etc.), adhesive (e.g., glue, etc.), mechanical fasteners, etc.) if desired.

[0080] FIGS. 27-30 illustrate another example embodiment of a dispensing assembly 400 according to the present disclosure. The dispensing assembly 400 of this embodiment is

again substantially similar to the dispensing assembly 100 illustrated in FIGS. 1-20. For example, the dispensing assembly 400 generally includes a container 404 and a sprayer 406. And, the sprayer 406 is configured to couple to the container 404.

[0081] In this embodiment, the sprayer 406 includes an arm 442 releasably coupled to the sprayer 406. In particular, a tab 476 is formed along an upper side portion of the sprayer 406, and a slot 478 is formed in an end portion of the arm 442. The slot 478 of the arm 442 is configured (e.g., keyed, etc.) to receive (e.g., slide over, etc.) the tab 476 of the sprayer 406 to thereby releasably couple the arm 442 to the sprayer 406. Thus, in this embodiment, the arm 442 can again be formed separate from the sprayer 406 and subsequently coupled thereto as desired (e.g., when assembling the sprayer 406, when assembling the dispensing assembly 400, etc.). The sprayer 406 and the arm 442 of the sprayer 406 can again be formed from any suitable process (e.g., a molding process, etc.). In other example embodiments, dispensing assemblies may include sprayers similar to the sprayer 406 of the dispensing assembly 400, but where arms of the sprayers include tabs and where the sprayers include slots configured to receive the tabs of the arms for use in releasably coupling the arms to the sprayers. What's more, it should be appreciated that the tabs and the slots can have any desired configurations (e.g., any desired keyed configurations such as, for example, tongue-and-groove configurations, etc.) within the scope of the present disclosure.

[0082] The sprayer 406 initially couples to the container 404 (e.g., when initially assembling the dispensing assembly 400, etc.) by positioning the arm 442 (which is already coupled to the sprayer 406) over a handle 426 of the container 404 and within a groove 430 provided around at least part of the handle 426. The arm 442 is resiliently flexible to provide a snap-fit coupling of the arm over (and at least partly around) the handle 426. A generally first portion 442a of the arm 442 is disposed along an upper portion of the handle 426. A generally second portion 442b of the arm 442 is disposed along a rearward portion of the handle 426. A first lip 446 of the arm 442 is disposed generally under the handle 426. And, a second lip of the arm 442 is disposed along a forward portion of the handle 426. In addition, the sprayer 406 is positioned within a recess 454 defined by the container 404. A forward side surface of the sprayer 406 is generally flush with a non-recessed surface portion of a forward wall 414, an upper surface of the sprayer 406 is generally flush, coplanar, etc. with an upper surface of the

handle 426, and a right side surface (as viewed in FIG. 27) of the sprayer 406 is generally flush with a side wall 420 of the container 404.

[0083] In use, to uncouple the sprayer 406 from the container 404, the sprayer 406 is separated from the arm 442 by moving the tab 476 of the sprayer 406 out of the slot 478 of the arm 442. The arm 442 remains coupled to the handle 426 of the container 404. Then, to recouple the sprayer 406 to the container 404, the tab 476 of the sprayer 406 is positioned (e.g., slid, etc.) back within the recess 478 of the arm 442.

[0084] FIGS. 31 and 32 illustrate another example embodiment of a dispensing assembly 500 according to the present disclosure. The dispensing assembly 500 is substantially similar to the dispensing assembly 100 illustrated in FIGS. 1-20. For example, the dispensing assembly 500 generally includes a container 504 and a sprayer 506. And, the sprayer 506 is configured to couple to the container 504. In this embodiment, however, the sprayer 506 includes an arm 542 with a generally arcuate shape. The arm 542 can be formed as one piece with the sprayer 506, or the arm 542 can be formed separate from the sprayer 506 and coupled thereto within the scope of the present disclosure. In addition, the arm 542 may be resiliently flexible to help provide a friction fit between the arm 542 and the handle 526 (to thereby help hold the sprayer 506 on the container 504). In use, the sprayer 506 couples to the container 504 by positioning the arm 542 over a handle 526 of the container 504 (e.g., within a groove 530 provided around at least part of the handle 526, etc.). In this position, a forward portion of the handle 526 is received within a channel 556 defined by ribs 544 of the sprayer 506. The arm 542 may be resiliently flexible to help provide a friction fit between the arm 542 and the handle 526 (to thereby help hold the sprayer 506 on the container 504). Further, the weight of the sprayer 506 (combined with the offset positioning of the arm 542) may also help hold the sprayer 506 on the container 504. Ribs may be provided along the arm 542 and/or along the sprayer 506 to help reinforce the arm 542, for example, when flexing the arm 542 to couple the sprayer 506 to the container 504, etc.

[0085] FIGS. 33-35 illustrate another example embodiment of a dispensing assembly 600 according to the present disclosure. The dispensing assembly 600 is substantially similar to the dispensing assembly 100 illustrated in FIGS. 1-20. For example, the dispensing assembly 600 generally includes a container 604 and a sprayer 606. And, the sprayer 606 is configured to couple to the container 604 (in similar fashion to that previously described for the dispensing

assembly 100). In this embodiment, the sprayer 606 includes an arm 642 pivotally coupled to the sprayer 606 along hinge 684. The arm 642 can be formed as one piece (e.g., monolithically, etc.) with the sprayer 606 such that the hinge 684 is a living hinge coupling the arm 642 to the sprayer 606. Or, the arm 642 can be formed separate from the sprayer 606 and pivotally coupled thereto via the hinge 684 (e.g., using a piano hinge, etc.). Ribs 644a are formed along an upper portion of the arm 642. And, corresponding ribs 644b are formed along an upper portion of the sprayer 606 which are configured to abut the ribs 644a of the arm 642 when the arm 642 is pivoted upward into position for coupling the sprayer 606 to the container 604. The arm 642 and/or container 604 may further include structure (e.g., tabs, etc.) that operate to secure the arm 642 in the position for coupling the sprayer 606 to the container 604 (e.g., upon pivoting the arm 606 upward, etc.).

[0086] Thus, in this embodiment, the sprayer 606 can be initially formed with the arm 642 positioned generally downward (e.g., adjacent a handle portion 606b of the sprayer 606, etc.) and not extended (e.g., for shipping, etc.) (FIG. 34). The arm 642 can then be extended, for example, when assembling the dispensing assembly 600 so that the sprayer 606 can be coupled to the container 604 (FIG. 35). It should be appreciated that the arm 642 of the sprayer 606 can have any desired shape within the scope of the present disclosure such as, for example, an L-shape as illustrated in FIGS. 33-35, a C-shape, etc.

[0087] In other example embodiments of the present disclosure, dispensing assemblies generally includes containers and sprayers. In one of these example embodiments, a container has a height of about 12 inches, a width of about 7.75 inches, and a depth of about 4.25 inches. A handle opening of the container has a width of about 3.47 inches and a height of about 0.79 inches. And, a sprayer has a height of about 6.1 inches, a width of about 3.3 inches, and a depth of about 1.1 inches.

[0088] In other example embodiments of the present disclosure, dispensing assemblies may include sprayers and containers, where the sprayers include arms configured to resiliently snap-fit to vertical portions of handles of the containers. In so doing, the sprayers may be located within recesses defined by walls of the containers, and upper surfaces of the sprayers may be generally aligned with upper surfaces of the containers, when the sprayers are coupled to the containers. Here, the handles may be oriented along upper surfaces of the containers, along vertical surfaces (e.g., side walls, etc.) of the containers, etc.

[0089] In other example embodiments of the present disclosure, dispensing assemblies may include sprayers and containers where the sprayers include arms shaped substantially similar to the arms disclosure herein (e.g., arms 142, 242, 342, 442, 542, 642, etc.), but generally inverted. Here, the arms of the sprayers may be resiliently flexible to help provide a snap-fit coupling of the arms generally under (and at least partly around) the handles of the containers. For example, first portions of the arms may be disposed along lower portions of the handles, second portions of the arms may be disposed along rearward portions of the handles, and lips of the arms may be disposed generally over the handles.

[0090] In other example embodiments of the present disclosure, dispensing assemblies may include sprayers and containers where the sprayers (e.g., clip portions of the sprayers, etc.) couple to portions of the containers other than the handles. In these example embodiments, the sprayers are still located generally higher on the containers (when coupled to the containers) such that, for example, upper portions of the sprayers are still positioned generally coplanar, aligned, flush, etc. with upper portions of the containers (e.g., with upper portions of the handles of the containers when the containers include handles along their upper portions; with upper portions, upper surfaces, etc. of the containers when the containers do not include upper handles, etc.). For example, the sprayers may couple to upper surfaces of the containers below the handles (e.g., within openings defined below the handles, etc.), or to upper surfaces of the containers when the containers do not include such upper handles, or to side surfaces of the containers, or to vertical portions of handles of the containers, etc. Also for example, the sprayers may couple to the containers within openings defined below the handles of the containers (e.g., to upper surfaces of the containers below the handles and/or to lower surfaces of the of the handles).

[0091] Specific dimensions included herein are exemplary in nature and do not limit the scope of the present disclosure. In addition, specific dimensions included herein are provided within acceptable tolerances generally common in the art (e.g., dimensions with no decimal point may include tolerances of +/- 0.12; dimensions with one decimal point may include tolerances of +/- 0.6; dimensions with two decimal points may include tolerances of +/- 0.03; etc.).

[0092] Example embodiments are provided so that this disclosure will be thorough, and will fully convey the scope to those who are skilled in the art. Numerous specific details are set forth such as examples of specific components, devices, and methods, to provide a thorough

understanding of embodiments of the present disclosure. It will be apparent to those skilled in the art that specific details need not be employed, that example embodiments may be embodied in many different forms and that neither should be construed to limit the scope of the disclosure. In some example embodiments, well-known processes, well-known device structures, and well-known technologies are not described in detail.

[0093] The terminology used herein is for the purpose of describing particular example embodiments only and is not intended to be limiting. As used herein, the singular forms "a," "an," and "the" may be intended to include the plural forms as well, unless the context clearly indicates otherwise. The terms "comprises," "comprising," "including," and "having," are inclusive and therefore specify the presence of stated features, integers, steps, operations, elements, and/or components, but do not preclude the presence or addition of one or more other features, integers, steps, operations, elements, components, and/or groups thereof. The method steps, processes, and operations described herein are not to be construed as necessarily requiring their performance in the particular order discussed or illustrated, unless specifically identified as an order of performance. It is also to be understood that additional or alternative steps may be employed.

[0094] When an element or layer is referred to as being "on," "engaged to," "connected to," or "coupled to" another element or layer, it may be directly on, engaged, connected or coupled to the other element or layer, or intervening elements or layers may be present. In contrast, when an element is referred to as being "directly on," "directly engaged to," "directly connected to," or "directly coupled to" another element or layer, there may be no intervening elements or layers present. Other words used to describe the relationship between elements should be interpreted in a like fashion (e.g., "between" versus "directly between," "adjacent" versus "directly adjacent," etc.). As used herein, the term "and/or" includes any and all combinations of one or more of the associated listed items.

[0095] Although the terms first, second, third, etc. may be used herein to describe various elements, components, regions, layers and/or sections, these elements, components, regions, layers and/or sections should not be limited by these terms. These terms may be only used to distinguish one element, component, region, layer or section from another region, layer or section. Terms such as "first," "second," and other numerical terms when used herein do not imply a sequence or order unless clearly indicated by the context. Thus, a first element,

component, region, layer or section discussed below could be termed a second element, component, region, layer or section without departing from the teachings of the example embodiments.

[0096] Spatially relative terms, such as "inner," "outer," "beneath," "below," "lower," "above," "upper," and the like, may be used herein for ease of description to describe one element or feature's relationship to another element(s) or feature(s) as illustrated in the figures. Spatially relative terms may be intended to encompass different orientations of the device in use or operation in addition to the orientation depicted in the figures. For example, if the device in the figures is turned over, elements described as "below" or "beneath" other elements or features would then be oriented "above" the other elements or features. Thus, the example term "below" can encompass both an orientation of above and below. The device may be otherwise oriented (rotated 90 degrees or at other orientations) and the spatially relative descriptors used herein interpreted accordingly.

[0097] The foregoing description of the embodiments has been provided for purposes of illustration and description. It is not intended to be exhaustive or to limit the disclosure. Individual elements or features of a particular embodiment are generally not limited to that particular embodiment, but, where applicable, are interchangeable and can be used in a selected embodiment, even if not specifically shown or described. The same may also be varied in many ways. Such variations are not to be regarded as a departure from the disclosure, and all such modifications are intended to be included within the scope of the disclosure.

The embodiments of the present invention for which an exclusive property or privilege is claimed are defined as follows:

1. A dispensing assembly for dispensing fluid at desired targets, the dispensing assembly comprising:

a container having a handle; and

a sprayer having an arm extending away from the sprayer, the arm defining a channel configured to receive at least part of the handle of the container within the channel to thereby couple the sprayer to the container;

wherein, when the sprayer is coupled to the container, the arm of the sprayer extends at least partly around the handle of the container and a lip of the arm engages the handle.

2. The dispensing assembly of claim 1, wherein the handle of the container is located toward an upper portion of the container and includes a groove; and

wherein the arm of the sprayer extends away from an upper surface of the sprayer, the groove configured to receive at least part of the arm of the sprayer into the groove when the sprayer is coupled to the container.

3. The dispensing assembly of claims 1 or 2, wherein the container includes a forward wall defining a recess, the recess configured to receive the sprayer when the sprayer is coupled to the container.

4. The dispensing assembly of any one of claims 1-3, wherein the arm of the sprayer defines an L-shape.

5. The dispensing assembly of claim 1, wherein the lip is configured to extend at least partly under the handle of the container when the sprayer is coupled to the container.

6. The dispensing assembly of any one of claims 1-5, wherein the sprayer includes a head portion and a handle portion arranged in a pistol-style configuration.

7. The dispensing assembly of claim 6, wherein the arm is monolithically formed with the head portion of the sprayer.

8. The dispensing assembly of claim 1 or 5, wherein the arm is coplanar with an upper surface of the sprayer.

9. The dispensing assembly of any one of claims 1-8, wherein the sprayer is disposed within a footprint of the container when the sprayer is coupled to the container.

10. The dispensing assembly of any one of claims 1-9, wherein the sprayer is disposed within a perimeter defined by the container when the sprayer is coupled to the container.

11. The dispensing assembly of claim 1 or 5, wherein an upper surface of the sprayer is substantially coplanar with an upper surface of the handle of the container when the sprayer is coupled to the container.

12. A method of making a dispensing assembly suitable for use to dispense fluid at desired targets, the method comprising:

forming a container having a forward wall defining a recess, and having a handle located toward an upper portion of the container; and

forming a sprayer having an arm for coupling the sprayer to the handle of the container, the arm extending away from the sprayer and defining a channel configured to receive at least part of the handle of the container into the channel to thereby couple the sprayer to the handle of the container;

wherein, when the sprayer is coupled to the container, the recess of the container is configured to receive the sprayer so that the sprayer is disposed within a footprint of the container.

13. The method of claim 12, wherein forming the container having the handle further includes forming a groove around at least part of the handle, the groove configured to receive the arm of the sprayer at least partly into the groove when the sprayer is coupled to the handle of the container.

14. The method of claim 12 or 13, wherein forming the sprayer includes forming the arm of the sprayer in an L-shape.

15. The method of any one of claims 12-14, wherein forming the sprayer includes forming the sprayer with a head portion and a handle portion arranged in a pistol-style configuration.

16. The method of claim 15, wherein forming the sprayer includes forming the arm of the sprayer monolithically with the head portion of the sprayer.

17. The method of any one of claims 12-16, wherein forming the sprayer includes forming the arm of the sprayer coplanar with an upper surface of the sprayer.

18. The method of any one of claims 12-17, wherein forming the sprayer includes forming the arm of the sprayer to substantially align with an upper surface of the handle of the container when the sprayer is coupled to the handle of the container.

19. The method of any one of claims 12-18, further comprising coupling the sprayer to the container.

20. A dispensing assembly for dispensing fluid at desired targets, the dispensing assembly comprising:

- a container having an upper portion; and
- a sprayer having an arm extending away from the sprayer, the arm configured to couple to the container such that an upper surface of the sprayer is substantially coplanar with the upper portion of the container;

wherein, when the sprayer is coupled to the container, the sprayer is disposed within a footprint defined by a bottom portion of the container;

wherein the container includes a handle located toward the upper portion of the container, and wherein the arm of the sprayer includes a channel configured to receive at least part of the handle of the container within the channel to thereby couple the sprayer to the container.

21. The dispensing assembly of claim 20, wherein the container includes a forward wall defining a recess, the recess configured to receive the sprayer when the sprayer is coupled to the container.

22. The dispensing assembly of claim 20 or 21, wherein the arm is monolithically formed with a head portion of the sprayer.

23. The dispensing assembly of any one of claims 20-22, wherein the sprayer is disposed within a perimeter defined by the container when the sprayer is coupled to the container.

24. The dispensing assembly of claim 20, wherein, when the sprayer is coupled to the container, the upper surface of the sprayer is substantially coplanar with an upper surface of the handle.

25. A dispensing assembly for dispensing fluid at desired targets, the dispensing assembly comprising:

a container for holding fluid;

a handle associated with the container, the handle defining an opening between the container and the handle; and

a sprayer for dispensing the fluid from the container, the sprayer having an arm extending away from the sprayer for use in releasably coupling the sprayer to the container, at least part of the arm configured to extend into the opening defined between the handle and the container when the sprayer is coupled to the container; wherein the arm of the sprayer defines a channel configured to receive at least part of the handle within the channel when the sprayer is coupled to the container.

26. The dispensing assembly of claim 25, wherein the arm extends away from an upper surface of the sprayer.

27. The dispensing assembly of claim 25, wherein the sprayer further includes a rib spaced apart from the arm; and

wherein, when the sprayer is coupled to the container, the handle is received between the arm and the rib of the sprayer.

28. The dispensing assembly of claim 25, wherein the container includes a wall defining a recess, the recess configured to receive the sprayer such that the sprayer is disposed within a footprint defined by the container when the sprayer is coupled to the container.

29. The dispensing assembly of claim 25, wherein the sprayer includes a head portion and a handle portion; and

wherein at least part of the head portion of the sprayer is aligned with the opening defined between the handle and the container when the sprayer is coupled to the container.

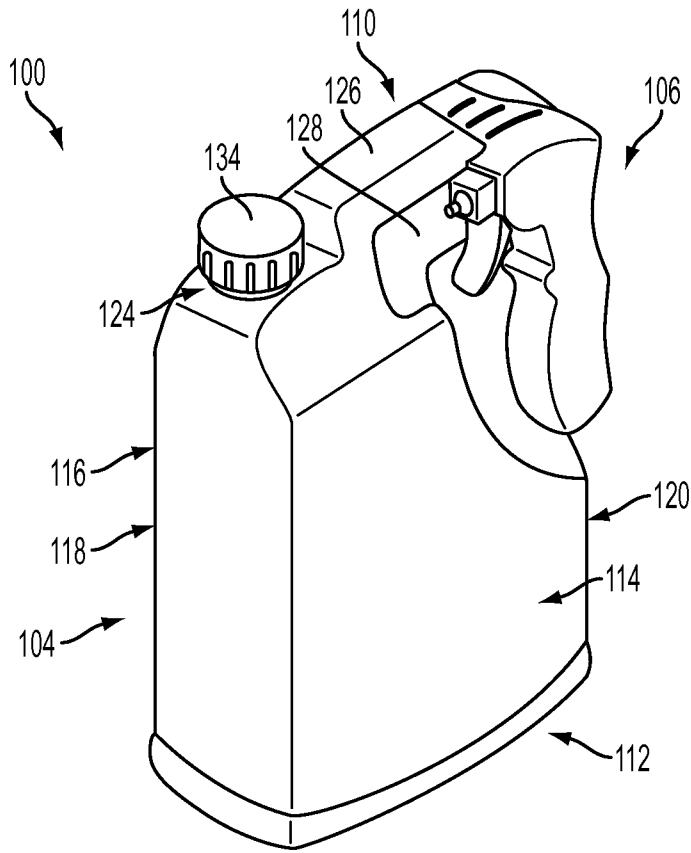

FIG. 1

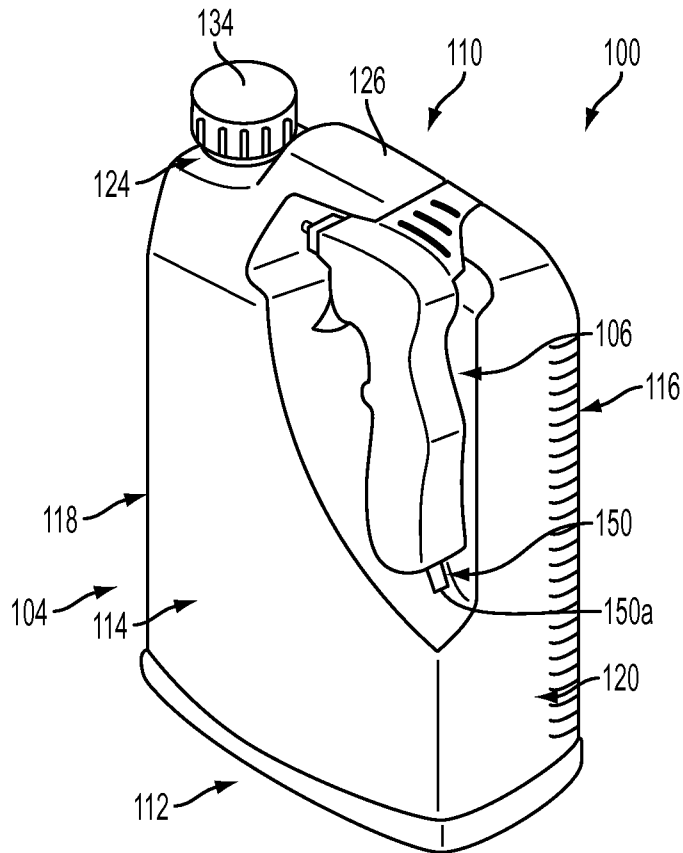

FIG. 2

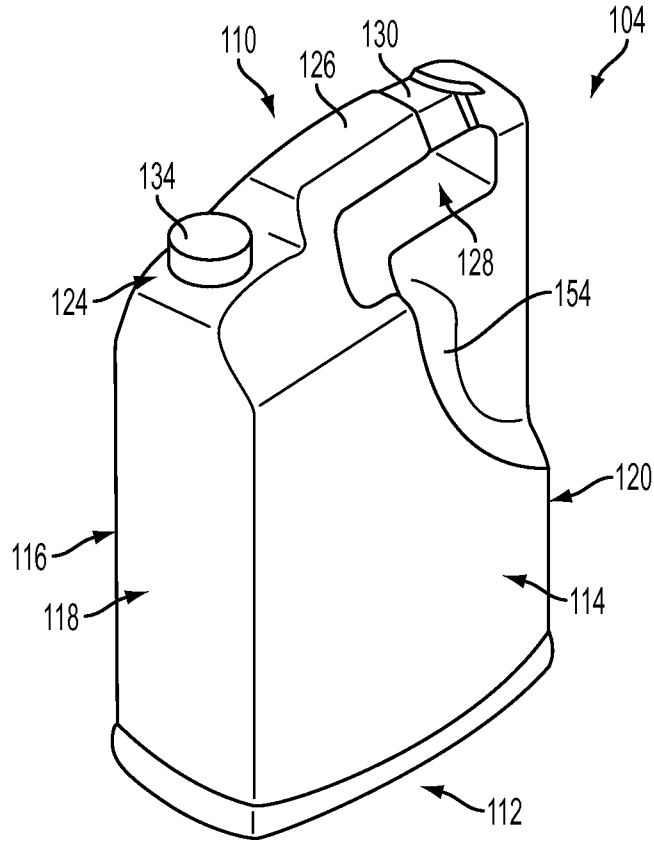

FIG. 3

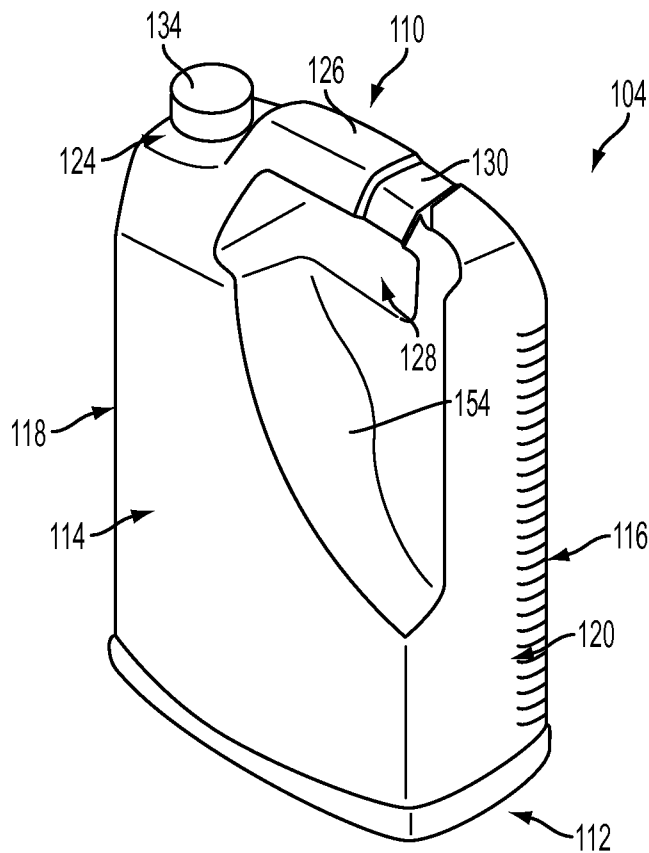

FIG. 4

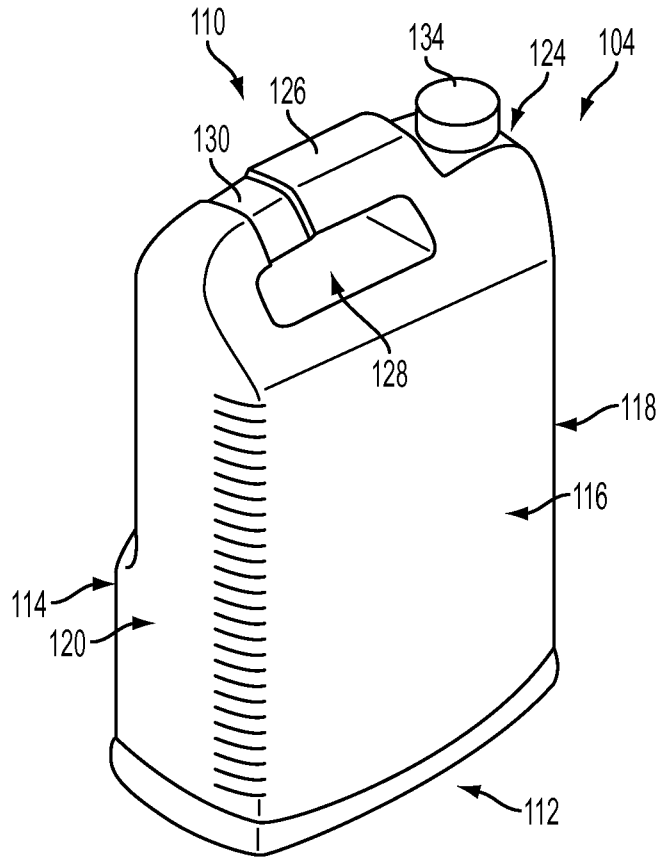

FIG. 5

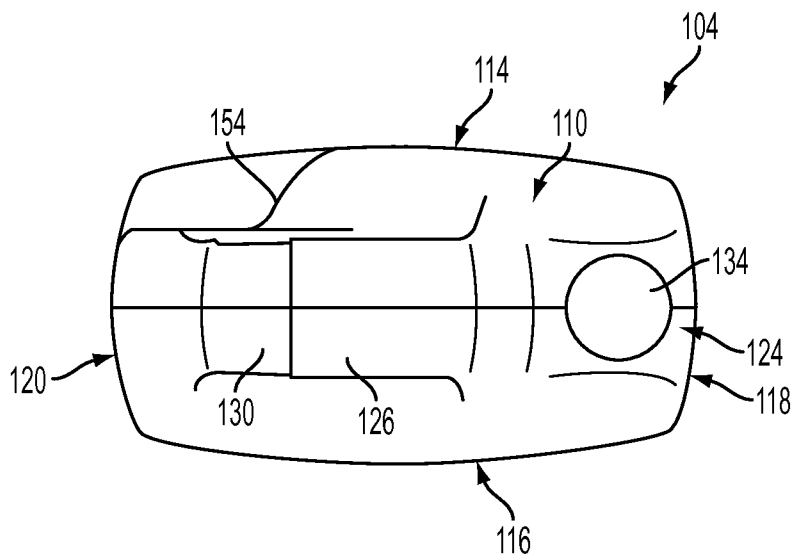

FIG. 6

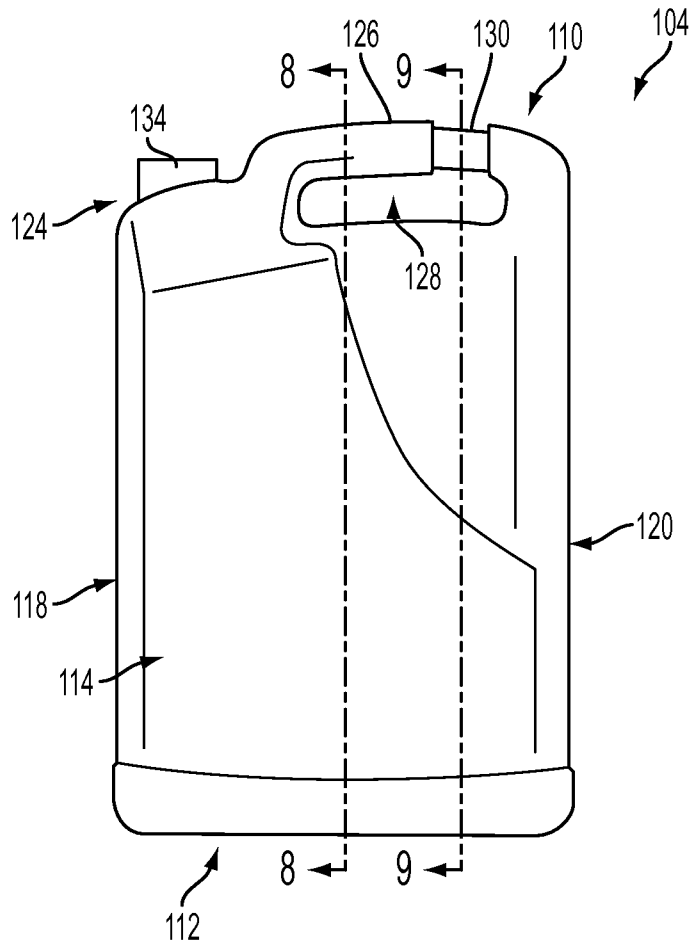

FIG. 7

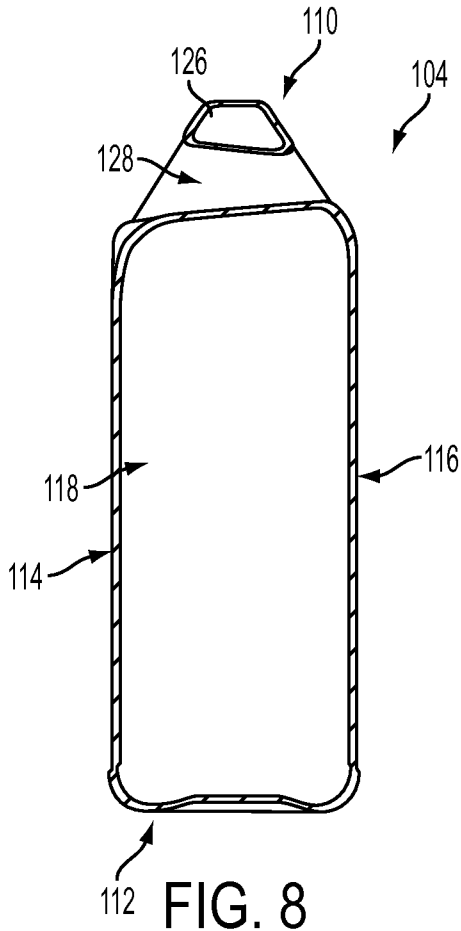

FIG. 8

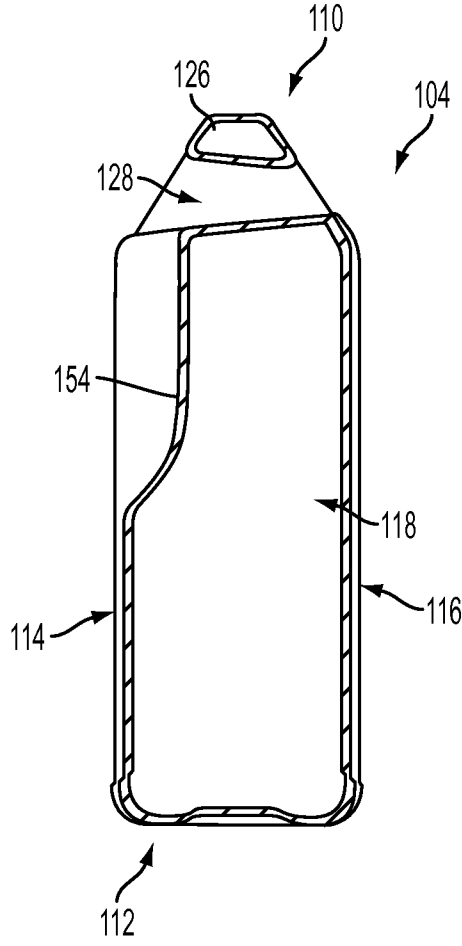

FIG. 9

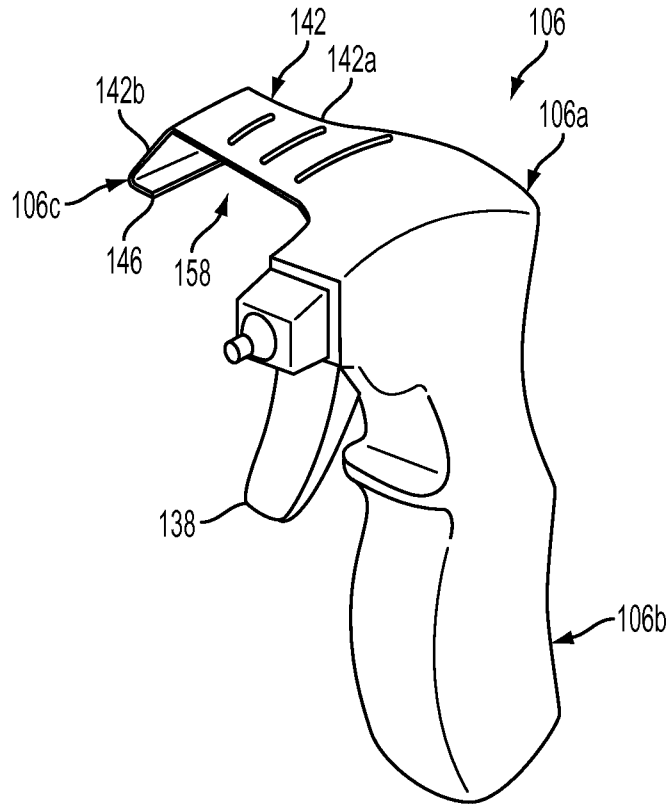

FIG. 10

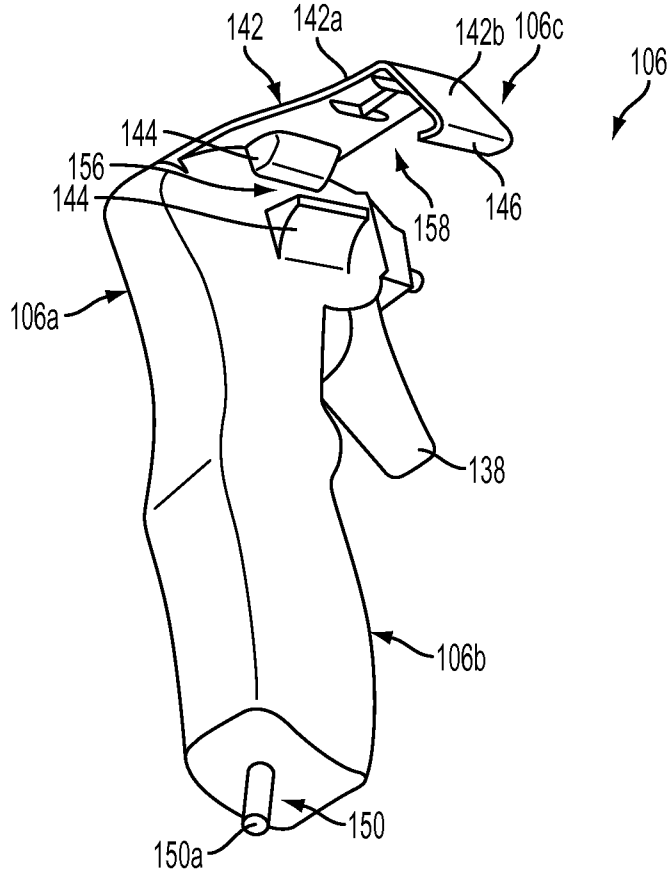

FIG. 11

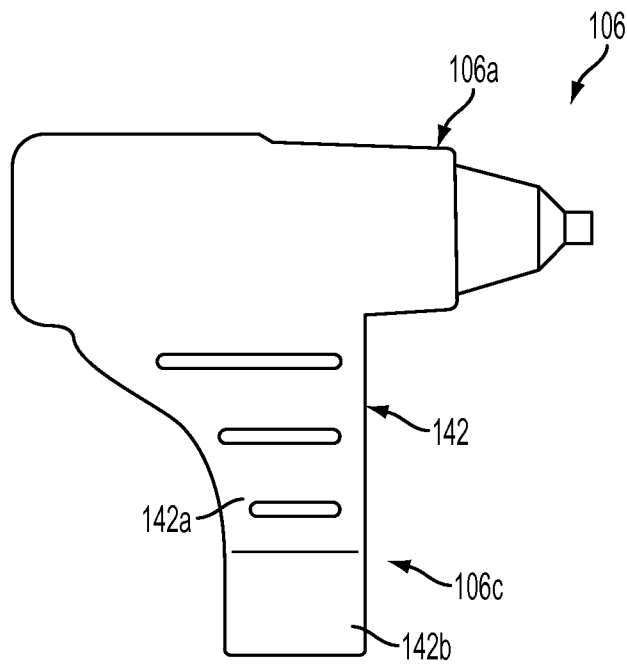

FIG. 12

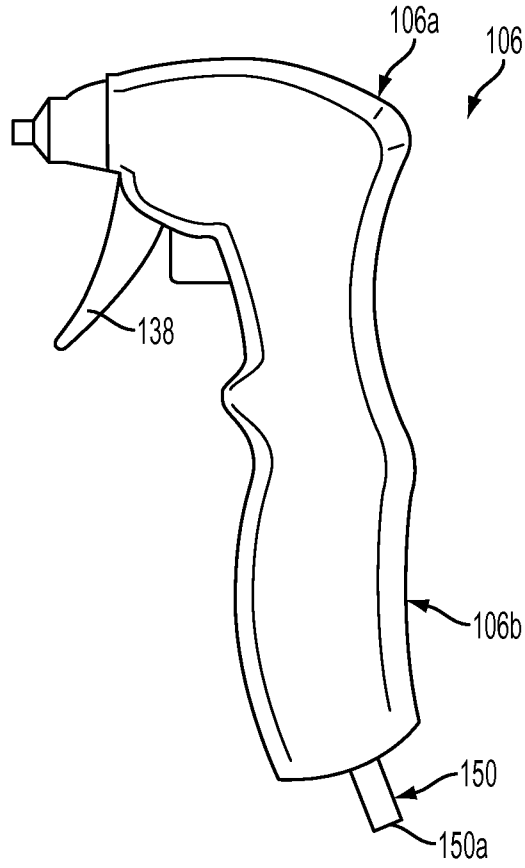

FIG. 13

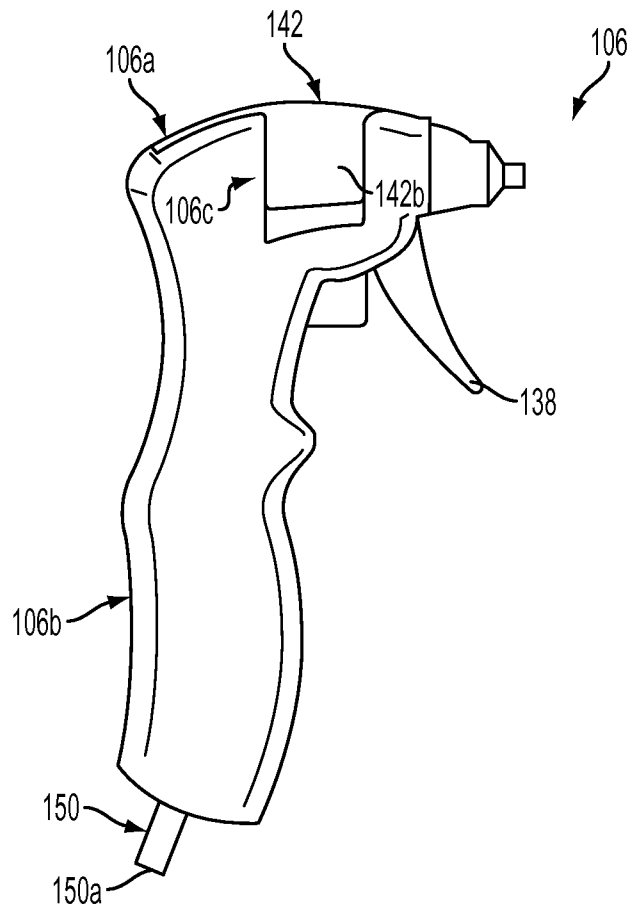

FIG. 14

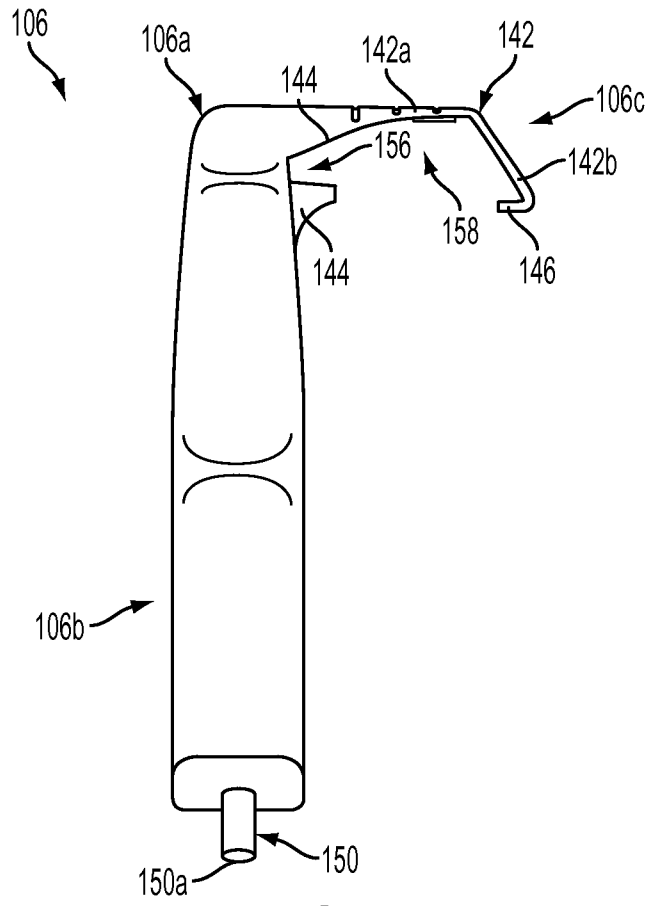

FIG. 15

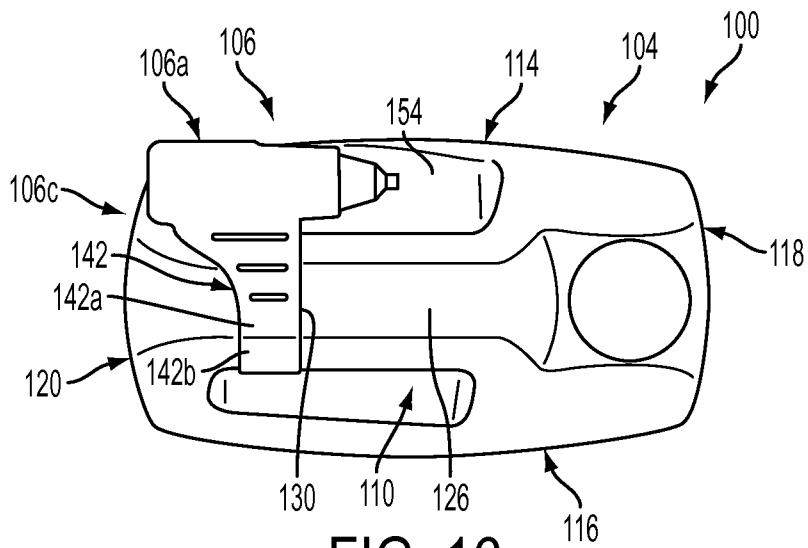

FIG. 16

9/18

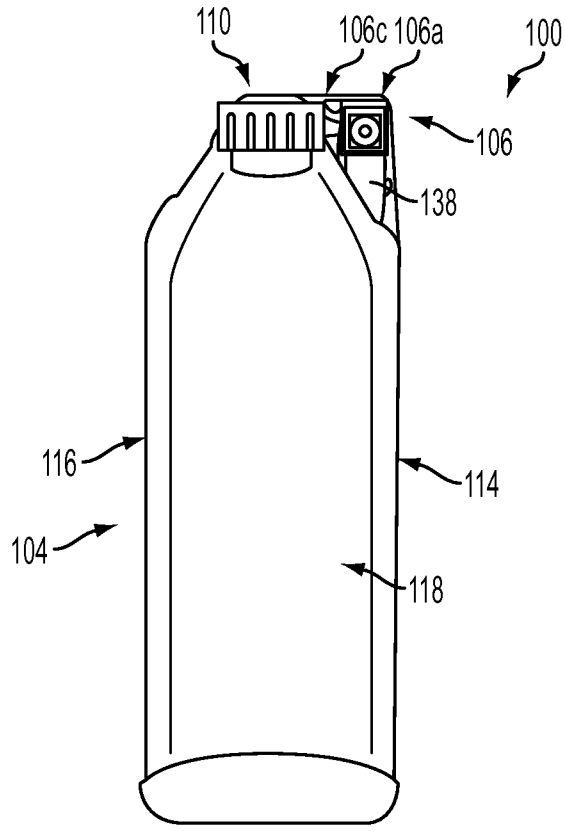

FIG. 17

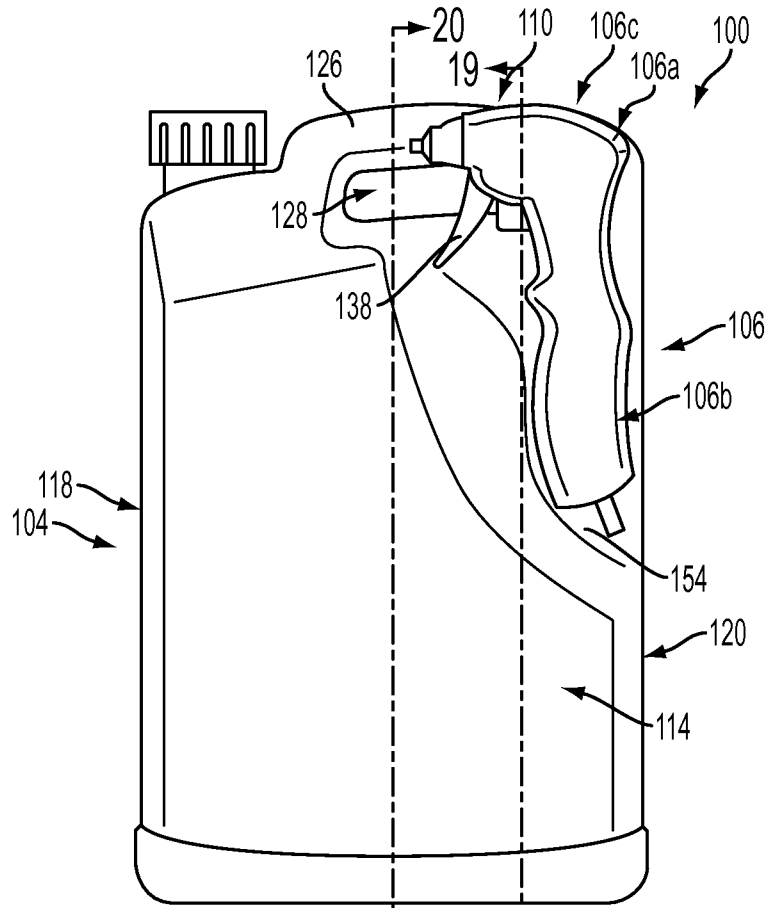

FIG. 18

10/18

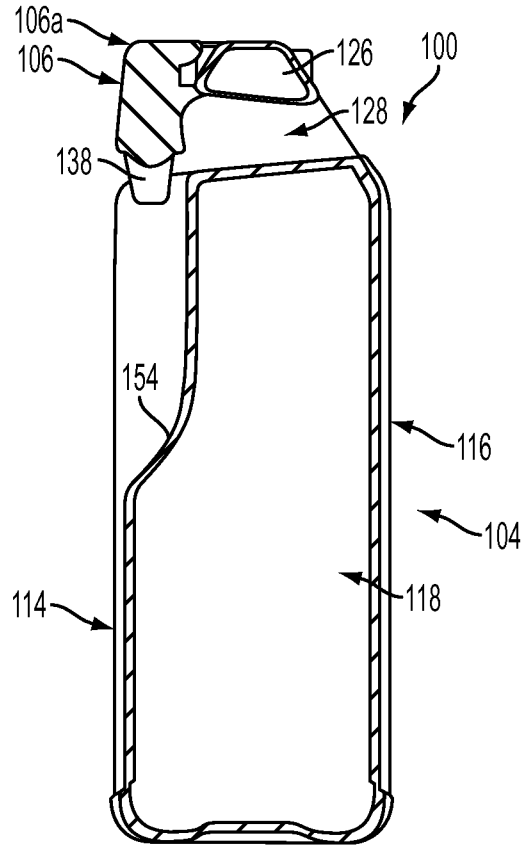

FIG. 19

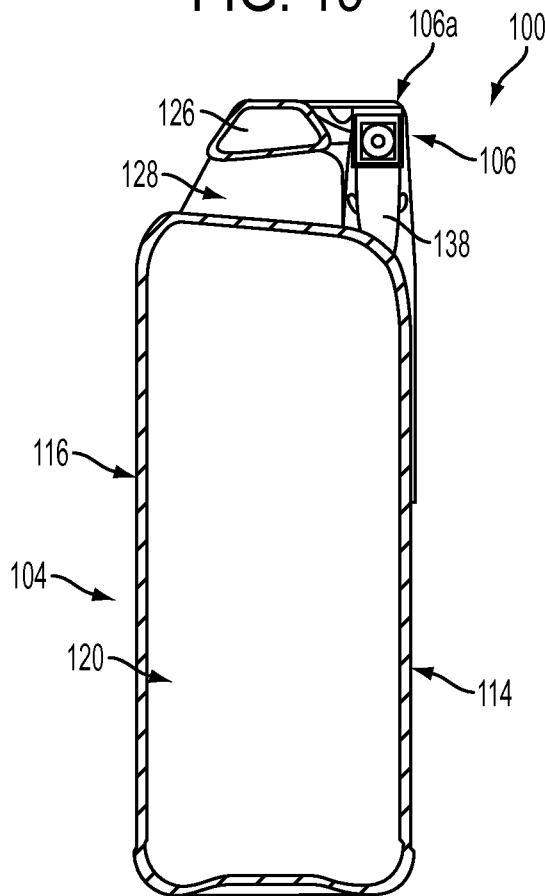

FIG. 20

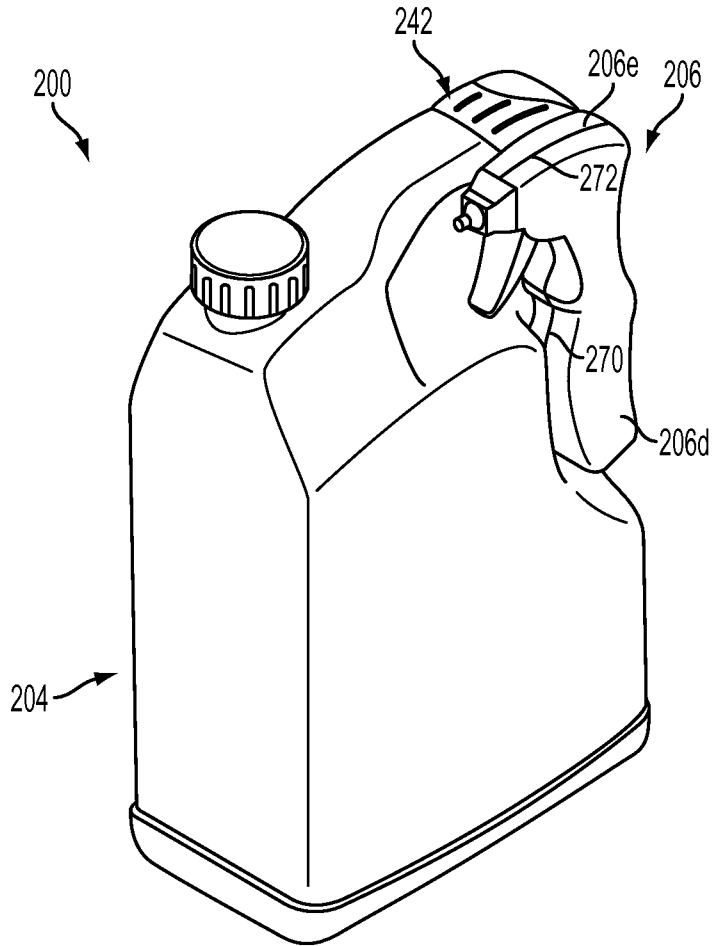

FIG. 21

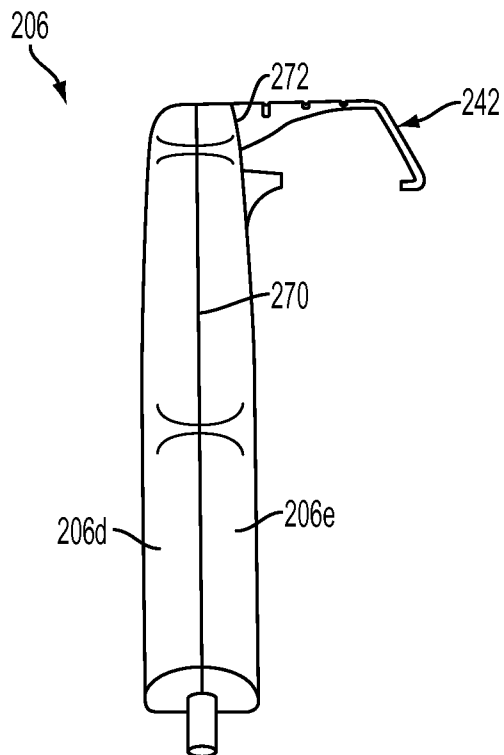

FIG. 22

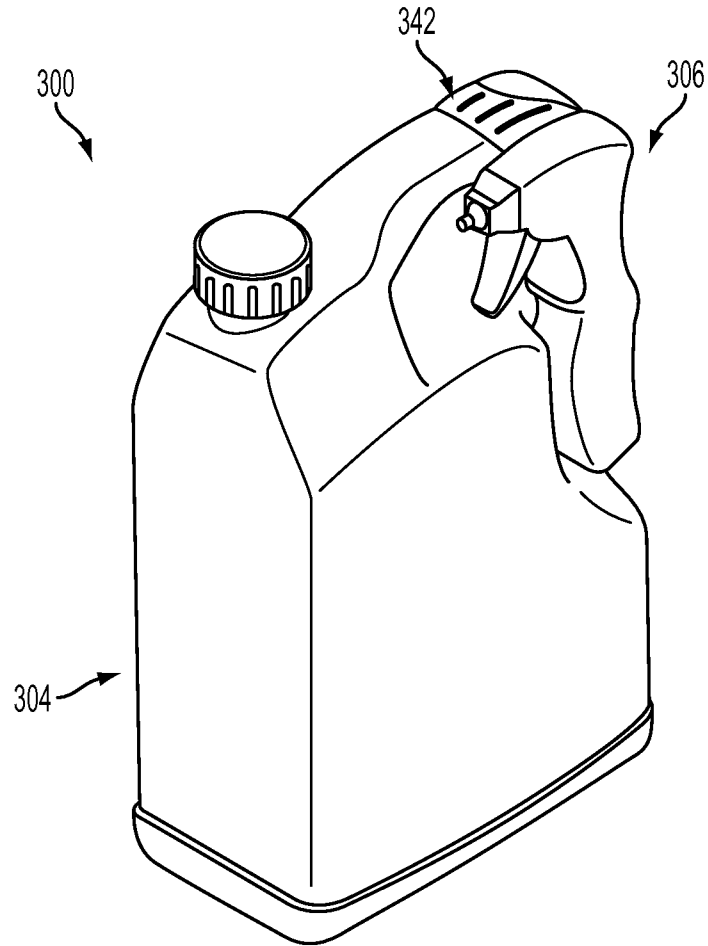

FIG. 23

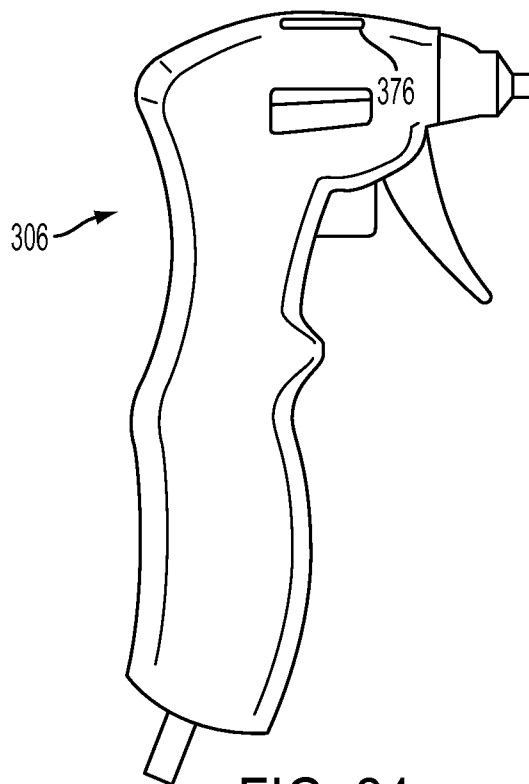

FIG. 24

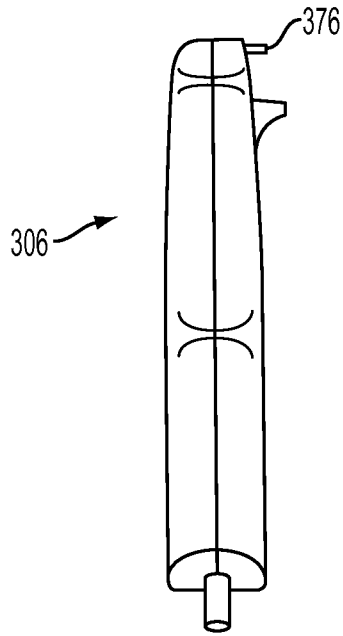

FIG. 25

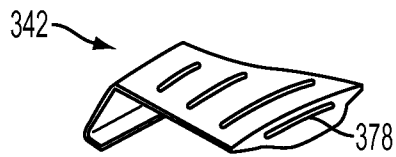

FIG. 26

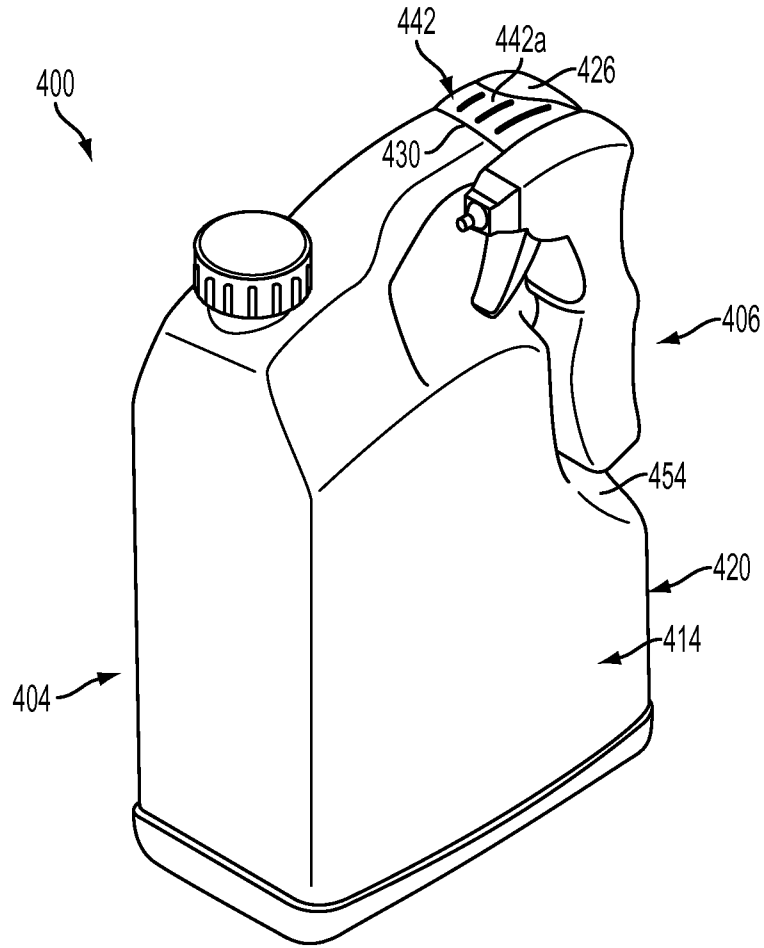

FIG. 27

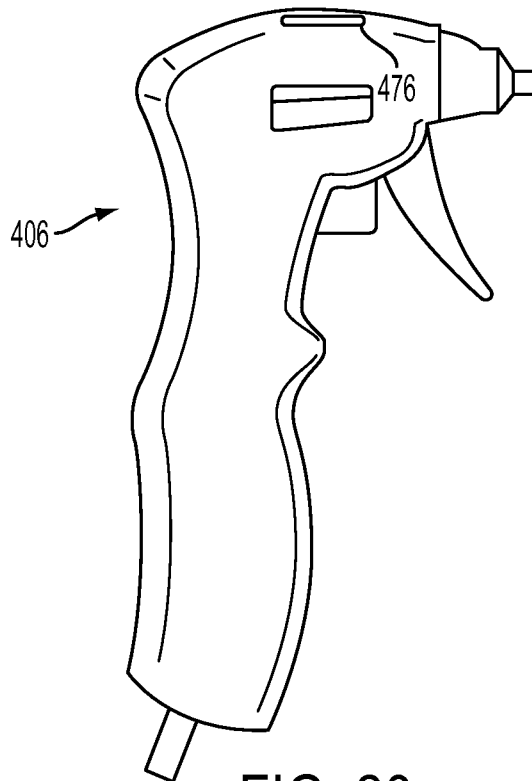

FIG. 28

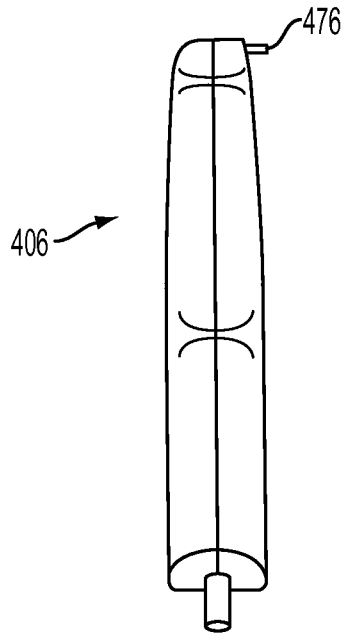

FIG. 29

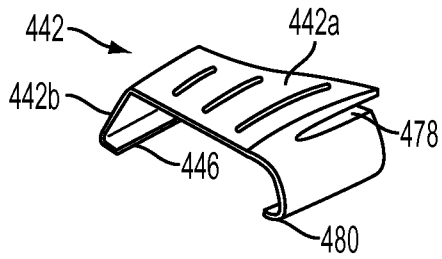

FIG. 30

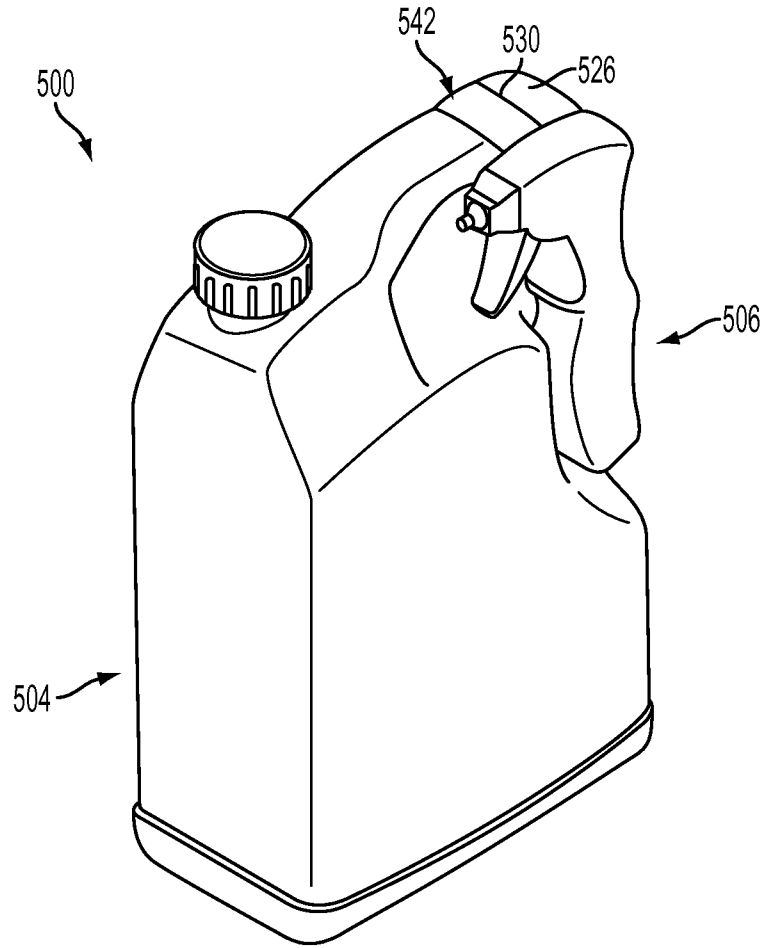

FIG. 31

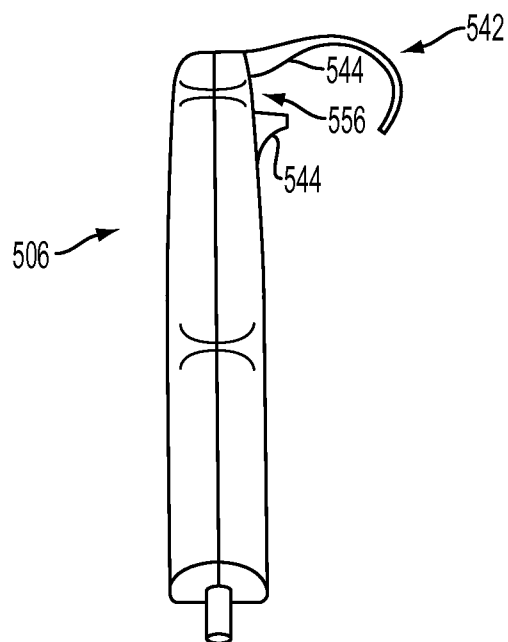

FIG. 32

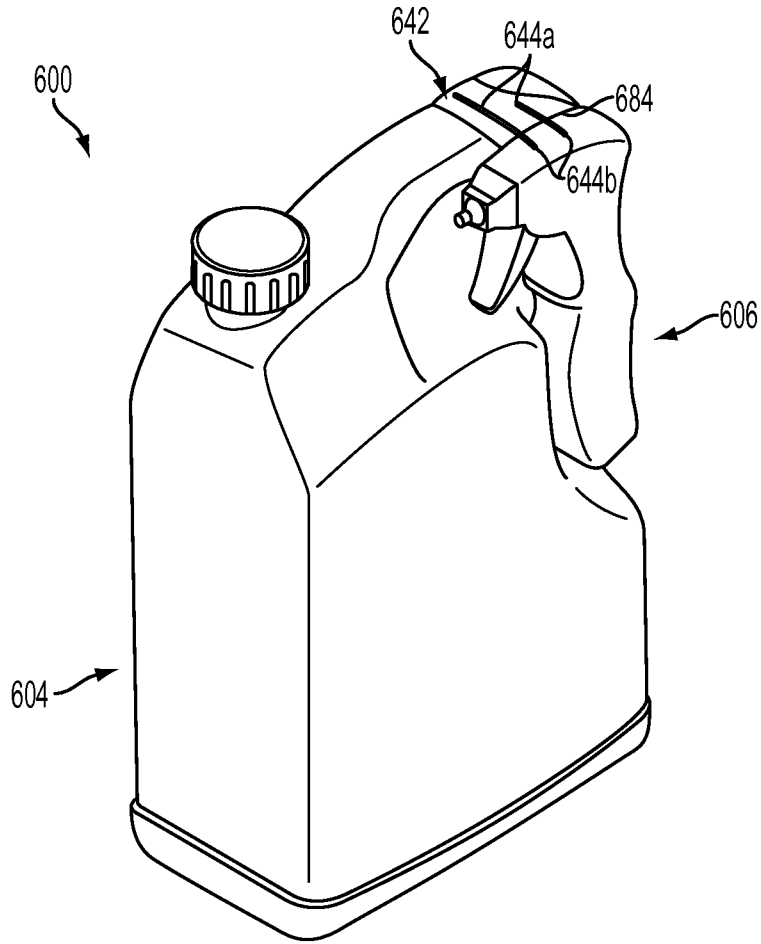

FIG. 33

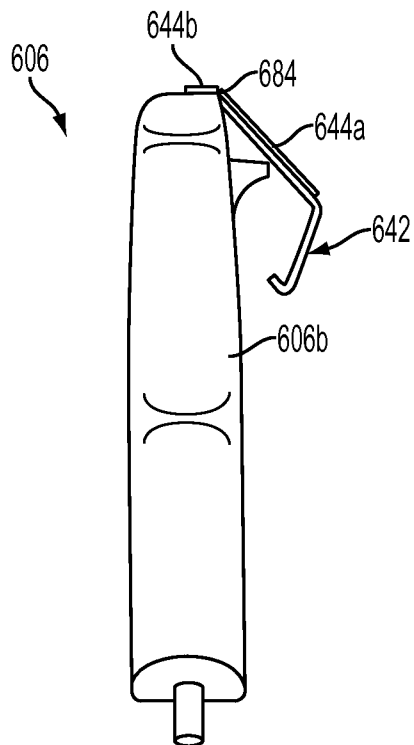

FIG. 34

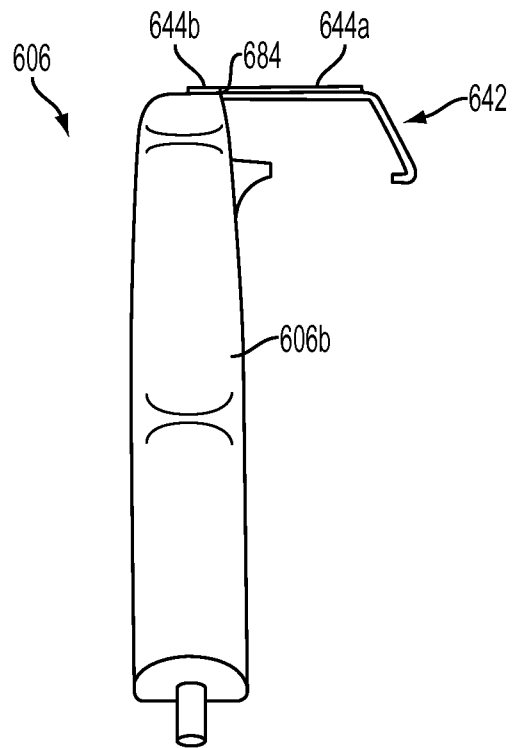

FIG. 35

