

June 22, 1954

G. C. JOHNSON

2,682,020

ELECTROMAGNET WITH U-SHAPED ARMATURE

Filed June 6, 1951

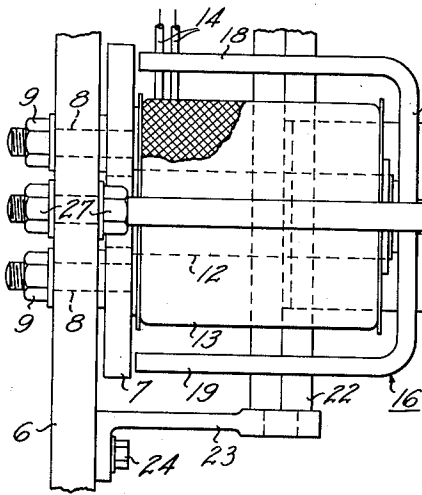

Fig. 1

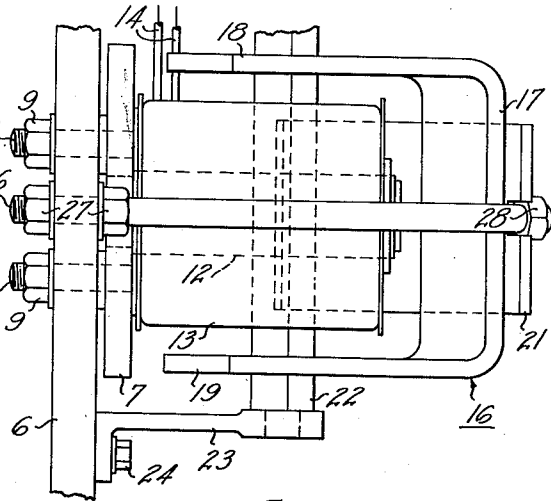

Fig. 3

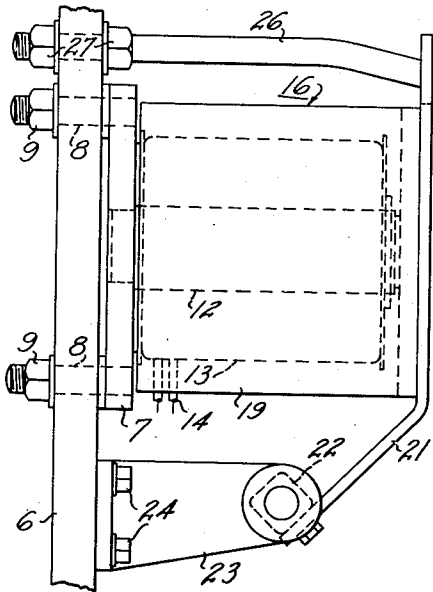

Fig. 2

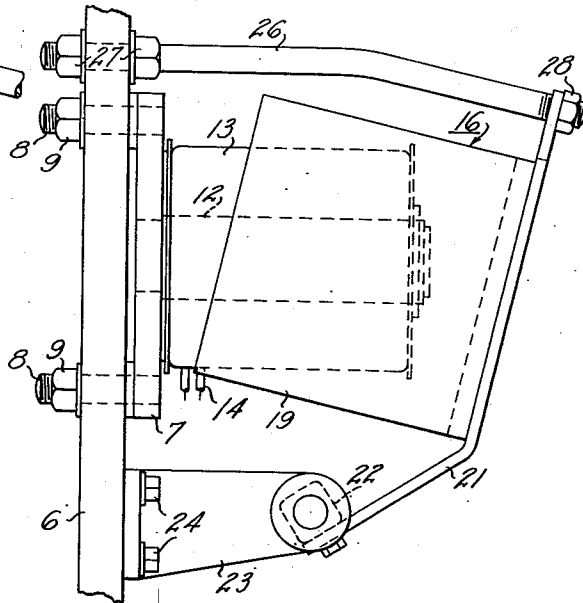

Fig. 4

Inventor
George E. Johnson
by Walter S. Madden, Jr.
Attorney

UNITED STATES PATENT OFFICE

2,682,020

ELECTROMAGNET WITH U-SHAPED ARMATURE

George C. Johnson, Milwaukee, Wis., assignor to
Allis-Chalmers Manufacturing Company, Milwaukee, Wis.

Application June 6, 1951, Serial No. 230,183

3 Claims. (Cl. 317-165)

1

This invention relates in general to electromagnets with armatures and in particular to means for improving the operating characteristics of such electromagnets.

In many electromagnets, a considerable portion of the flux produced by the exciting coil does not go through the armature when the armature is in the unattracted position, owing to the fact that the permeance of the leakage flux path is not negligible compared to the permeance of the air gap between the electromagnet core and the armature. This is especially true in electromagnets having E-shaped cores with an exciting coil mounted on the center leg of the core and a flat clapper-type armature attractable toward the core. In such devices, a substantial portion of the flux travels directly from the center leg to the adjacent outer core legs without going through the armature when the armature is in the unattracted position. This leakage flux results in a decreased pulling force on the armature when the exciting coil is energized, producing less torque for a given energization of the exciting coil than if all of the flux traveled through the armature.

This disadvantage may be overcome by utilizing an electromagnet in which a U-shaped armature shields the path of the leakage flux so that substantially all of the flux travels through the armature when the armature is in the unattracted position.

It is therefore an object of this invention to provide an electromagnet with an armature having improved operating characteristics.

It is an additional object of the present invention to provide an electromagnet with an armature in which maximum utilization is made of flux produced therein.

Objects and advantages other than those set forth above will be readily apparent from the following description when read in connection with the accompanying drawing, in which:

Fig. 1 is a top view of the electromagnet of this invention with the armature in the attracted position;

Fig. 2 is a side view of the device shown in Fig. 1;

Fig. 3 is a top view of the device with the armature in the unattracted position, and

Fig. 4 is a side view of the device with the armature in the unattracted position.

Referring to the drawing by character of reference, numeral 6 designates a nonmagnetic supporting member on which the electromagnet is mounted. The electromagnet comprises a fixed

2

core having a magnetic base member or plate 7 secured to member 6 by any suitable means such as studs 8 and nuts 9. A magnetic leg member 12 of the electromagnet core is secured to base member 7 and extends perpendicularly therefrom. Suitable exciting means, such as an electromagnetic coil 13 having input leads 14, are mounted on leg member 12 to produce flux in the core.

The device further comprises a movable U-shaped armature 16 attractable toward the core upon energization of coil 13. Armature 16 has a base portion 17 forming the bight of the U and has spaced depending side portions 18, 19 forming the legs of the U. Side portions 18, 19 are disposed on each side of leg member 12 and extend toward base member 7. Armature 16 is carried by a mounting member 21 which is secured to pivot means including a rotatable actuating shaft 22. Shaft 22 is journaled in brackets 23 secured to member 6 by bolts 24. Electric contacts (not shown) may be secured to shaft 22 to be actuated in response to movement of armature 16. A curved stud 26 secured to member 6 by nuts 27 extends through a notch in mounting member 21 and is provided with a nut 28 on the end thereof which engages member 21 to form stop means for limiting the travel of armature 16.

When coil 13 is deenergized, armature 16 is biased by gravity to the position shown in Figs. 3 and 4, with nut 28 preventing further movement thereof. When coil 13 is energized, the flux produced in the core extends through leg member 12 to the pole face formed by the end of leg member 12 remote from member 7, thence across the air gap to armature 16, through side portions 18, 19, across the air gaps between portions 18, 19 and member 7 and through member 7 to member 12. It will be seen from the drawing that members 18, 19 shield the path of leakage flux between the pole face end of member 12 and base member 7. The result thereof is that compared to the permeance of the flux path between the end of member 12 and any portion of armature 16, the permeance of the air gap between the pole face end of member 12 and member 7 is negligible, so that substantially all the flux travels through armature 16. This results in an increased pull on armature 16 when coil 13 is energized to improve the operating characteristics of the device. Armature 16 is thereupon attracted toward the core, with base portion 17 engaging the end of leg member 12 in the fully attracted position.

3

Although but one embodiment has been illustrated and described, it will be apparent to those skilled in the art that various changes and modifications may be made therein without departing from the spirit of the invention or from the scope of the appended claims.

It is claimed and desired to secure by Letters Patent:

1. An electromagnetic device comprising a magnetic core having a magnetic base member and a magnetic leg member having a first end and a second end, said first end secured to said base member to extend said leg member perpendicularly therefrom, an exciting coil mounted on said leg member, and a movable U-shaped armature attractable toward said core upon energization of said coil, said armature having a base portion forming the bight of the U and a pair of spaced side portions being disposed on each side of said leg member and extending toward said base member, the distance between said second end of said leg member and all portions of said armature being substantially less than the distance between said second end of said leg member and all portions of said core other than said leg member when said armature is in the unattracted position, whereby substantially all the flux produced by said exciting coil travels through said armature.

2. An electromagnetic device comprising a nonmagnetic supporting member, a magnetic core secured to said supporting member, said core having a magnetic base member and a magnetic leg member having a first end and a second end, said first end secured to said base member to extend said leg member perpendicularly therefrom, an exciting coil mounted on said leg member, a U-shaped armature attractable toward said core upon energization of said coil, and pivot means secured to said supporting member for pivotally supporting said armature, said armature having a base portion forming the bight of the U and a pair of spaced side portion forming the legs of

4

the U, said side portions being disposed on each side of said leg member and extending toward said base member, the distance between said second end of said leg member and all portions of said armature being substantially less than the distance between said second end of said leg member and all portions of said core other than said leg member when said armature is in the unattracted position, whereby substantially all of the flux produced by said exciting coil travels through said armature.

3. An electromagnetic device comprising a nonmagnetic supporting member, a magnetic core secured to said member, said core having a magnetic base member and a magnetic leg member having a first end and a second end, said first end secured to said base member to extend said leg member perpendicularly therefrom, an exciting coil mounted on said leg member, a movable U-shaped armature attractable toward said core upon energization of said coil, means for pivoting said armature about a predetermined axis, said armature having a base portion forming the bight of the U and a pair of spaced side portions forming the legs of the U, said side portions being disposed on each side of said leg member and extending toward said base member, the shortest distances between said second end of said leg member and said base portion of said armature and between said side portions of said armature and said core being in a direction substantially perpendicular to said axis and substantially parallel to the direction of movement of said armature, whereby maximum pull is exerted on said armature when said exciting coil is energized.

References Cited in the file of this patent

UNITED STATES PATENTS

Number	Name	Date
961,242	Larsen	June 14, 1910
1,203,325	Warren	Nov. 7, 1916
1,503,090	Carichoff	July 29, 1924