

(19) World Intellectual Property Organization  
International Bureau



(43) International Publication Date  
15 December 2005 (15.12.2005)

PCT

(10) International Publication Number  
WO 2005/118251 A3

(51) International Patent Classification:

A61M 31/00 (2006.01) B65D 33/00 (2006.01)  
A61M 37/00 (2006.01) A61B 19/00 (2006.01)  
B29B 7/00 (2006.01) B29C 33/40 (2006.01)

(21) International Application Number:

PCT/US2005/018583

(22) International Filing Date: 26 May 2005 (26.05.2005)

(25) Filing Language: English

(26) Publication Language: English

(30) Priority Data:

60/575,020 27 May 2004 (27.05.2004) US

(71) Applicant: WEST PHARMACEUTICAL SERVICES, INC. [US/US]; 101 Gordon Drive, Lionville, PA 19341 (US).

(72) Inventors: CONARD, William, A.; 1041 Bordeaux Lane, Pennsburg, PA 18073 (US). BUCK, Robert; 209 Grover Road, Watsontown, PA 17777 (US). STRAUS-BAUGH, Neil; 309 Adams Street, Williamsport, PA 17701 (US). KING, Robert, J.; 6 Winding Way, Malvern,

PA 19355 (US). CRAMMER, Diane, M.; 206 Joneal Road, Phoenixville, PA 19460 (US).

(74) Agents: BELISARIO, Martin, G. et al.; Akin, Gump, Strauss, Hauer & Feld, L.L.P., One Commerce Square, Suite 2200, 2005 Market Street, Philadelphia, PA 19103 (US).

(81) Designated States (unless otherwise indicated, for every kind of national protection available): AE, AG, AL, AM, AT, AU, AZ, BA, BB, BG, BR, BW, BY, BZ, CA, CH, CN, CO, CR, CU, CZ, DE, DK, DM, DZ, EC, EE, EG, ES, FI, GB, GD, GE, GH, GM, HR, HU, ID, IL, IN, IS, JP, KE, KG, KM, KP, KR, KZ, LC, LK, LR, LS, LT, LU, LV, MA, MD, MG, MK, MN, MW, MX, MZ, NA, NG, NI, NO, NZ, OM, PG, PH, PL, PT, RO, RU, SC, SD, SE, SG, SK, SL, SM, SY, TJ, TM, TN, TR, TT, TZ, UA, UG, US, UZ, VC, VN, YU, ZA, ZM, ZW.

(84) Designated States (unless otherwise indicated, for every kind of regional protection available): ARIPO (BW, GH, GM, KE, LS, MW, MZ, NA, SD, SL, SZ, TZ, UG, ZM, ZW), Eurasian (AM, AZ, BY, KG, KZ, MD, RU, TJ, TM), European (AT, BE, BG, CH, CY, CZ, DE, DK, EE, ES, FI, FR, GB, GR, HU, IE, IS, IT, LT, LU, MC, NL, PL, PT, RO, SE, SI, SK, TR), OAPI (BF, BJ, CF, CG, CI, CM, GA, GN, GQ, GW, ML, MR, NE, SN, TD, TG).

[Continued on next page]

(54) Title: INJECTION PORT AND METHOD OF MAKING THE SAME

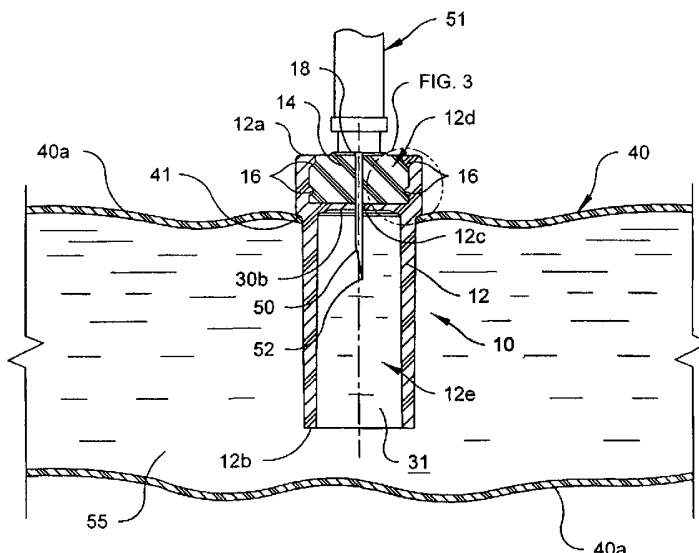

(57) Abstract: An injection port for an intravenous bag including a generally hollow tube that is mountable to the intravenous bag. The hollow tube has a first end. A polymeric plug is mounted in the first end. The polymeric plug is integrally molded into the tube proximate the first end. A method for construction the injection port including injecting a first molding material into a mold cavity, allowing the first molding material to at least partially cure and harden, moving a movable mold part to expose a first cavity defined by inner surfaces of the at least partially cured and hardened molding material, injecting a second mold material into the first cavity, allowing the second molding material to at least partially cure and harden such that the second molding material bonds with the inner surfaces and removing the injection port from the mold.

WO 2005/118251 A3



**Published:**

— *with international search report*

**(88) Date of publication of the international search report:**

18 January 2007

*For two-letter codes and other abbreviations, refer to the "Guidance Notes on Codes and Abbreviations" appearing at the beginning of each regular issue of the PCT Gazette.*

**INTERNATIONAL SEARCH REPORT**

International application No.

PCT/US05/18583

**A. CLASSIFICATION OF SUBJECT MATTER**  
 IPC: **A61M 31/00**( 2006.01);**37/00**( 2006.01);**B29B 7/00**( 2006.01);**B65D 33/00**( 2006.01);**A61B 19/00**( 2006.01)  
 B29C 33/40( 2006.01)  
 USPC: 604/408,6.16,403;264/225,328.8;383/96;128/DIG24  
 According to International Patent Classification (IPC) or to both national classification and IPC

**B. FIELDS SEARCHED**

Minimum documentation searched (classification system followed by classification symbols)  
 U.S. : 604/408,6.16,403;264/225,328.8;383/96;128/DIG24

Documentation searched other than minimum documentation to the extent that such documents are included in the fields searched

Electronic data base consulted during the international search (name of data base and, where practicable, search terms used)  
 EAST: port, plug or septum, elastomer, diaphragm, bag or container, injection molding,

**C. DOCUMENTS CONSIDERED TO BE RELEVANT**

Category *	Citation of document, with indication, where appropriate, of the relevant passages	Relevant to claim No.
X	US 3,064,652 A (CORCORAN et al.) 20 November 1962 (20.11.1962), entire document.	1, 2, 8, 10-14, 17, 18, 26-29
X	US 4,479,989 A (MAHAL) 30 October 1984 (30.10.1984), entire document.	1-19, 26-29
X, P --- Y, P	US 6,720,044 B2 (ANDERSSON et al.) 13 April 2004 (13.04.2004), entire document.	1-5, 8, 10-13 ----- 6, 9, 14, 17-19, 26-29
A	US 4,794,750 A (SCHMIDT et al.) 03 January 1989 (03.01.1989), entire document.	1, 2, 20-27
A	US 5,695,706 A (WELSH et al.) 09 December 1997 (09.12.1997), entire document.	20-25
A	US 3,184,524 A (WHITEFORD) 18 May 1965 (18.05.1965), entire document.	20-26

Further documents are listed in the continuation of Box C.  See patent family annex.

* Special categories of cited documents:	
"A" document defining the general state of the art which is not considered to be of particular relevance	"T" later document published after the international filing date or priority date and not in conflict with the application but cited to understand the principle or theory underlying the invention
"E" earlier application or patent published on or after the international filing date	"X" document of particular relevance; the claimed invention cannot be considered novel or cannot be considered to involve an inventive step when the document is taken alone
"L" document which may throw doubts on priority claim(s) or which is cited to establish the publication date of another citation or other special reason (as specified)	"Y" document of particular relevance; the claimed invention cannot be considered to involve an inventive step when the document is combined with one or more other such documents, such combination being obvious to a person skilled in the art
"O" document referring to an oral disclosure, use, exhibition or other means	"&" document member of the same patent family
"P" document published prior to the international filing date but later than the priority date claimed	

Date of the actual completion of the international search  
 17 September 2006 (17.09.2006)

Date of mailing of the international search report  
**31 OCT 2006**

Name and mailing address of the ISA/US  
 Mail Stop PCT, Attn: ISA/US  
 Commissioner for Patents  
 P.O. Box 1450  
 Alexandria, Virginia 22313-1450  
 Facsimile No. (571) 273-3201

Authorized officer *Sharon T. Greco for*  
 Patricia M. Bianco  
 Telephone No. (571) 272-2975