

Dec. 6, 1938.

A. MORETTI

2,139,557

SPOOL

Filed Nov. 6, 1936

2 Sheets-Sheet 1

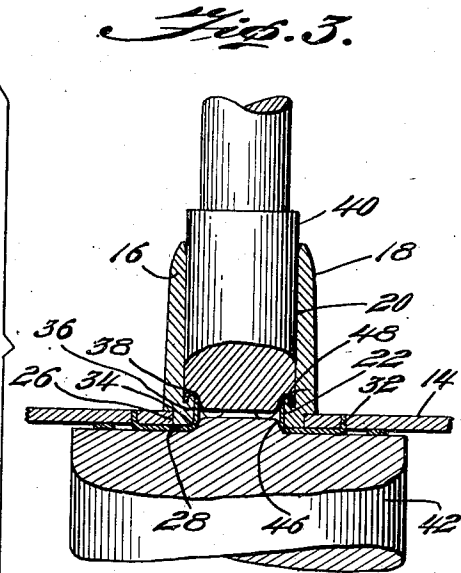
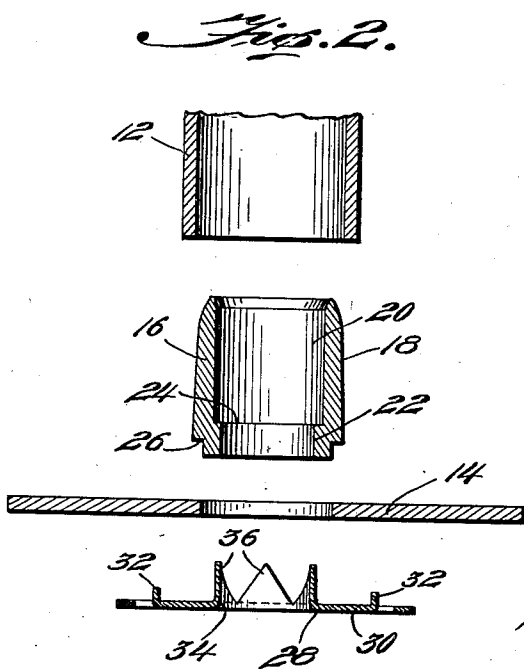
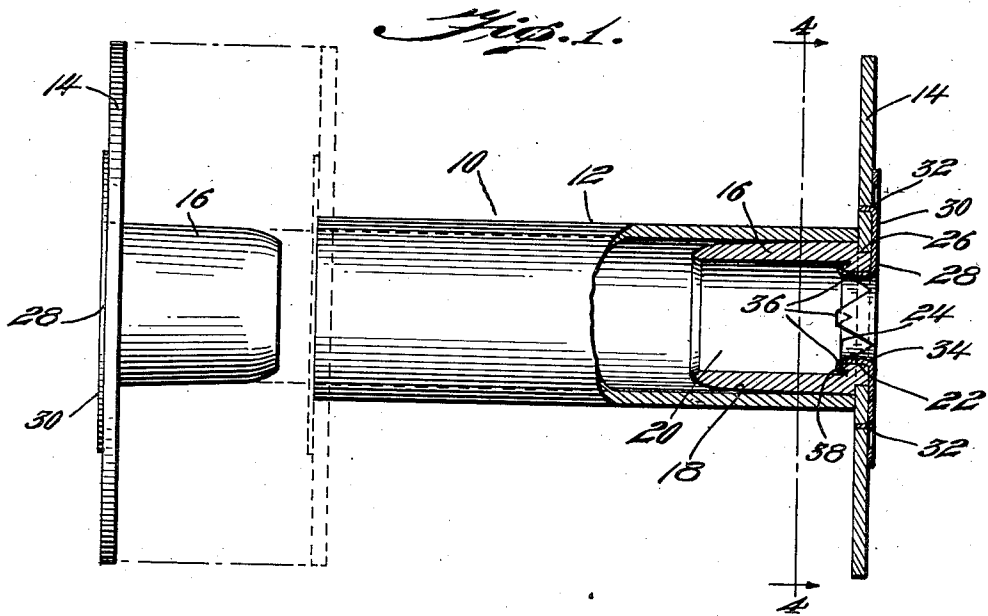

Inventor  
*Anthony Moretti*  
By *Thomas A. James*  
Attorney

Dec. 6, 1938.

A. MORETTI

2,139,557

SPOOL

Filed Nov. 6, 1936

2 Sheets-Sheet 2

*Fig. 4.*

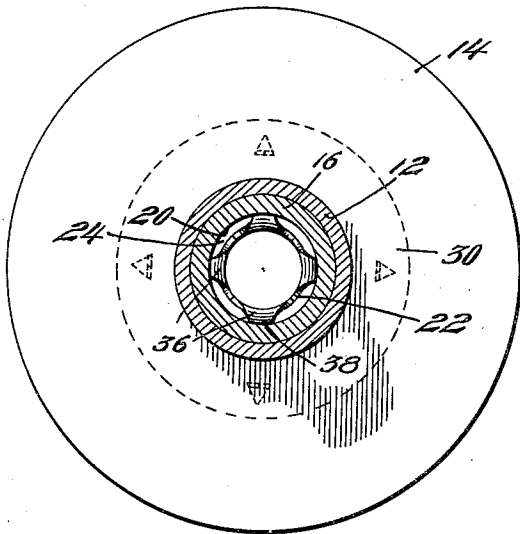

*Fig. 6.*

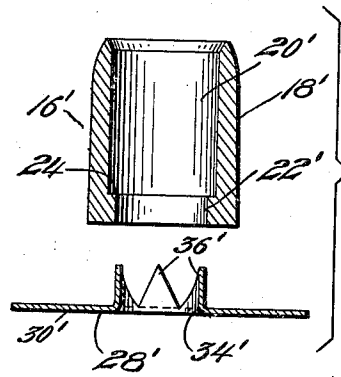

*Fig. 5.*

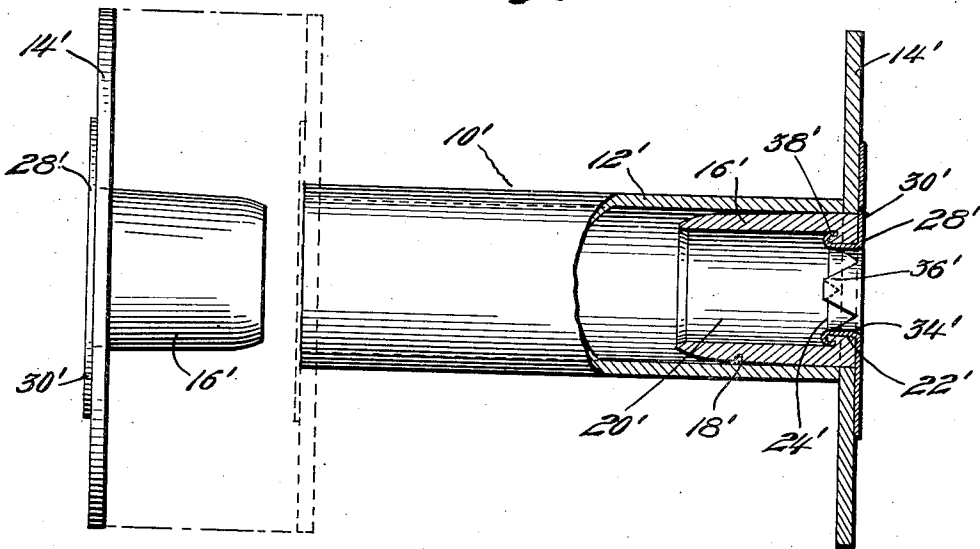

*Inventor*  
*Anthony Moretti*  
*By Thomas A. Jewell*  
*Attorney*

# UNITED STATES PATENT OFFICE

2,139,557

SPOOL

Anthony Moretti, Cranston, R. I.

Application November 6, 1936, Serial No. 109,525

5 Claims. (Cl. 242—124)

My invention relates to improvements in spools, whether they be of relatively small size for holding thread, ribbon, etc., or whether they be of larger size for winding larger types of materials thereon, and my invention particularly relates to an improved type of means for detachably securing the end heads or flanges of spools to the center barrels thereof.

An object of my invention is to provide a novel type of spool which may be constructed at a relatively small cost and one in which the head is rigidly and positively secured to the hub to stand up in use during a long period of time, particularly during rapid winding operations.

A further object of my invention is to provide an end head assembly which may be repeatedly used on a succession of center tubes and one which may be readily detached from said tubes for replacement purposes, and with this result in mind, I provide an assembly comprising a preferably wooden hollow tubular hub and an end cap member having an annular portion adapted to overlie the outer surface of said head when attached to the tube rigidly and permanently secured to said hub, and if desired clamping said head in such an assembly against an annular countersunk external shoulder formed in the outer end of said hub.

These and such other objects of my invention as may hereinafter appear will be best understood from a description of various embodiments thereof such as are shown in the accompanying drawings.

In the drawings, Fig. 1 is a side elevation of a spool constructed in accordance with my invention, one end thereof being shown in section, and with the end assembly for the opposite end thereof comprising in this embodiment a permanently attached head, cap and hub member detachably removed from said end of the tube in full lines.

Fig. 2 is a disassembled sectional view showing one end of a tube and a respective end assembly for said tube end, comprising a wooden hub member, a cardboard head and a metal cap.

Fig. 3 is a front elevation partially shown in section of a punch which may be used to attach one form of my unit end assembly comprising a hub member, head and cap together.

Fig. 4 is a sectional view taken along the line 4—4 of Fig. 1.

Fig. 5 is a side elevation partially broken away and shown in section and identical to Fig. 1 showing a different embodiment of my invention wherein the cap member is attached directly to the hub to provide a unit and the head member

is detachably clamped between the inner surface of said cap member and the outer end of said tube.

Fig. 6 is a disassembled sectional view similar to Fig. 2 showing the hub member and cap of this embodiment prior to being attached together in substantially the manner shown in Fig. 3.

In the drawings, wherein like characters of reference generally indicate like parts throughout, 10 generally indicates a spool assembly constructed in accordance with my invention. As stated hitherto, my invention particularly relates to the novel type of means and assembly I employ for detachably securing a rigid assembly of each end to permit the head to be detachably secured to an outer end of the center tubular portion 12. In either embodiment of my invention for providing such an assembly for detachably securing each respective head 14 to the end of each tube 12, I provide a hollow tubular preferably wooden hub member 16 preferably having an inwardly tapered outer surface 18 and a bore 20, said bore 20 having a reduced portion 22 extending a distance inwards from the outer end thereof forming an annular shoulder 24 at its inner end. I provide an annular, preferably fibre or cardboard head 14 for each end of said spool, each externally fitted on the outer end of each hub member 16, in my preferred embodiment shown in Figs. 1-4 being externally countersunk on the outer end of its hub member within an annular external countersink 26 of substantially the thickness of said head 14 on the outer end of its hub member 16. While I preferably construct each head of cardboard, it is apparent that it may be constructed of fibre or other composition, and I therefore employ the word fibre in the claims to signify cardboard or other analogous composition comprising fibre.

As a part of each end assembly, I preferably also provide a metal cap 28 having an annular portion 30 of less diameter than and abutting the outer surface of each head 14. If desired, portions of said annular head portion 30 may be indented into said head at intervals as shown at 32. This indentation may take place after assembly by striking the annular metal surface 30 with a sharp blow, but the indentations in each annular cap portion 30 are preferably made prior to assembly to provide the regularly spaced prongs 32 projecting axially inwardly from said head portion 30 adapted upon assembly, as shown in Fig. 3, to be forced within the head 14. If desired, however, as shown in Figs. 5 and 6, said indentations 32 may be omitted. The annu-

lar portion 30 of each cap member has an inner periphery 34 slightly less than that of said reduced bore 22 of its hub member 16 and each cap member has means, preferably spaced prong means 36 as shown, projecting axially inwardly from the inner periphery of said annular head portion 30 within said reduced hub member bore 22 to form a metal bearing for the spindle 34 upon which the spool may be mounted and having each inner end thereof forced axially outwardly as at 38 into the annular internal shoulder 24 on said hub member to secure each cap 28 to each head 14 and hub member 16.

It is thus apparent that in the preferred embodiment shown in Figs. 1-4, I provide an assembled unit for spool ends comprising a hub member 16, a head 14 and a cap 28 in which the cap is secured directly to the hub member clamping said head between said hub member and cap to provide a unit which may be assembled as shown in Fig. 3 and sold separately as a unit which will last a considerable length of time, often throughout the life of several tubes 12.

The embodiment shown in Figs. 5 and 6 comprises exactly the same members and has generally the same parts as in the embodiment shown in Figs. 1-4 with the exception that the annular external countersink is not provided on the outer end of said hub member 16 and hence each head member is not clamped between each cap and hub member but may be detachably fitted over the outer end of each hub member and clamped as shown in Fig. 5 between each end of the tube 12' and a cap 28' as shown in Fig. 5 or which may, if desired, be secured directly to the assembled hub member and cap unit by indenting the annular portion of said cap as at 32 into said head 14 as shown in Figs. 1-4. In this instance, my assembly unit may comprise the hub member 16' and cap member 28' detachably secured together as explained and as shown in Fig. 5 and said unit may, if desired, have the annular portion 30' of said cap member indented into the head 14' to add it to this respective unit or the head member may be sold and assembled separately and be merely clamped between the outer end of the tube and a cap member. If however the indentations 32 are employed, there will be much less chance for relative movement between each head 14 and cap 28. Either embodiment of my invention comprises an assembled head unit, whether it consists of the hub member and cap as shown at Fig. 6 or the hub member, head and cap as shown in Figs. 1-4, which is adapted to be secured to each end of the tube by fitting such tube end over each preferably inwardly tapered external surface of each hub member, at least in the embodiment shown in Figs. 5 and 6, so that the end thereof abuts the head member 14' to press it against each cap portion 30' to clamp it thereto.

I have shown in Fig. 3 a punch member 40 and die member 42 which may be used for assembling the end assembly unit comprising the cap 28, head 14 and hub member 16. In this instance, the die member 42 has a relatively large upper surface on which the outer surface of the head 14 may rest as it is pressed downward and a center circular protuberance 46 to compactly fit within the bore formed at the inner periphery 34 of the annular portion 30 of said cap member 28. Where the head member 14 is adapted to be countersunk on the external countersink 26 on the outer end of the hub member 16, said

head 14 is pressed over said cap member 28 mounted as explained on said die 42 and the hub member has the outer countersunk end 26 of less diameter forced within the inner periphery of said head 14 as shown. The punch 40 has a lower end having an annular concaved portion 48 near the outer edge thereof and as said punch 40 is lowered upon said die 42, it is obvious that said annular concaved portion 48 will bend the ends of the prongs 36 axially outwardly into the annular internal shoulder 24 on said hub member to secure each cap 28 to each hub member 16. This action also clamps said head between said hub member 16 and cap 28 to provide an assembled unit comprising said hub member 16, head 14 and cap 28 rigidly secured together. If the cap member 28 be pre-formed with the spaced axial prongs 32, it is obvious that during the punching operation illustrated in Fig. 3, they will be axially forced into said head. It is also apparent that the end unit shown in Figs. 5 and 6 comprising a hub member 16' and cap member 28' only may also be assembled on the same punch and die, the head 14 being separately attached to be clamped as explained between the outer end of the tube and the flange 30 of said cap member.

It is thus apparent that I have provided a novel type of spool assembly comprising the usual tube and assembled units at each end of the tube for securing each head 14 to each end of the tube 12 and which may, if desired, as shown in Figs. 1-4, include said head 14 as part of said assembly or which may not as shown in Figs. 5 and 6, with the advantages explained above.

It is understood that my invention is not limited to the specific embodiments shown and that various deviations may be made therefrom without departing from the spirit and scope of the appended claims:

What I claim is:

1. In a spool assembly, hollow tubular wooden hub members, each having an inwardly tapered external surface and a bore having a portion of reduced diameter extending inwards a distance from the outer end thereof forming an annular shoulder at its inner end, an annular fibre head for each end of said spool, each externally fitted on the outer end of each hub member, metal caps for each end of said spool, each comprising an annular portion of less diameter than and abutting each outer head surface having portions thereof indented into said head having an internal periphery slightly less than that of said reduced bore of the outer end of each hub member and spaced prong means projecting integrally axially inwardly from the internal periphery thereof within said reduced hub portion forming a spindle bearing having each inner end thereof extending axially outwardly into the surface of the annular internal shoulder on said hub member to secure each cap to each head and hub member and a hollow cardboard tube having each outer end thereof fitted over each external inwardly tapered surface of each hub member.

2. In a spool assembly, hollow tubular wooden hub members, each having a bore having a portion of reduced diameter extending inwards a distance from the outer end thereof forming an annular shoulder at its inner end, an annular fibre head for each end of said spool, each externally fitted on the outer end of each hub member, metal caps for each end of said spool, each comprising an annular portion of less diameter than and abutting each outer head surface hav-

ing an internal periphery slightly less than that of said reduced bore of the outer end of each hub member and spaced prong means projecting integrally axially inwardly from the internal periphery thereof within said reduced hub portion forming a spindle bearing having each inner end thereof extending axially outwardly into the surface of the annular internal shoulder on said hub member to secure each cap to each hub member and a hollow cardboard tube having each outer end thereof fitted over each external surface of each hub member.

3. In a spool assembly, hollow tubular wooden hub members, each having a bore having a portion of reduced diameter extending inwards a distance from the outer end thereof forming an annular shoulder at its inner end, an annular fibre head for each end of said spool, each externally loosely fitted on the outer end of each hub member, metal caps for each end of said spool, each comprising an annular portion of less diameter than and abutting each outer head surface having an internal periphery slightly less than that of said reduced bore of the outer end of each hub member and spaced prong means projecting integrally axially inwardly from the internal periphery thereof within said reduced hub portion forming a spindle bearing having each inner end thereof extending axially outwardly into the surface of the annular internal shoulder on said hub member to secure each cap to each hub member and a hollow cardboard tube having each outer end thereof fitted over each external surface of each hub member to abut each head and press it against each cap.

4. In a spool assembly, a hollow tubular wooden hub member having a bore having a portion of reduced diameter extending inwards a distance from the outer end thereof forming an annular shoulder at its inner end, an annular fibre head externally fitted on the outer end of said hub member and a metal cap comprising an annular portion of less diameter than and abutting said outer head surface and having an internal periphery slightly less than that of said reduced bore of the outer end of said hub and spaced prong means projecting integrally axially inwardly from the internal periphery thereof within said reduced hub bore forming a spindle bearing and having each inner end thereof extending axially outwardly into the surface of the annular internal shoulder on said hub to secure said cap to said hub member.

5. In a spool assembly, a hollow tubular wooden hub member having a bore having a portion of reduced diameter extending inwards a distance from the outer end thereof forming an annular shoulder at its inner end and a metal cap comprising an annular portion having an internal periphery slightly less than that of said reduced bore of the outer end of said hub and spaced prong means projecting integrally axially inwardly from the internal periphery thereof within said reduced hub bore forming a spindle bearing and having each inner end thereof extending axially outwardly into the surface of the annular internal shoulder on said hub to secure said cap to said hub member.

ANTHONY MORETTI. 35