



(51) International Patent Classification:

G01S 7/41 (2006.01) G01S 13/84 (2006.01)
G01S 13/34 (2006.01) G01S 13/36 (2006.01)
G01S 13/38 (2006.01) G01S 13/536 (2006.01)
G01S 13/88 (2006.01) G01S 13/87 (2006.01)

(21) International Application Number:

PCT/US2021/062263

(22) International Filing Date:

07 December 2021 (07.12.2021)

(25) Filing Language:

English

(26) Publication Language:

English

(30) Priority Data:

17/116,199 09 December 2020 (09.12.2020) US

(71) Applicant: **META PLATFORMS TECHNOLOGIES, LLC** [US/US]; 1601 Willow Road, Menlo Park, California 94025 (US).

(72) Inventors: **DANESHGARAN, Fereydoun**; 1601 Willow Road, Menlo Park, California 94025 (US). **KROGSTAD, Dustin Jeffrey Gordon**; 1601 Willow Road, Menlo Park, California 94025 (US). **DESALVO, Riccardo**; 1601 Willow Road, Menlo Park, California 94025 (US). **TIEN, Joseph Minh**; 1601 Willow Road, Menlo Park, California 94025 (US). **PEREZ, Omar Mikhail Ilagan**; 1601 Willow Road, Menlo Park, California 94025 (US). **MATTERA, Paolo**; 1601 Willow Road, Menlo Park, California 94025 (US). **PARENTE, Roberto**; 1601 Willow Road, Menlo Park, California 94025 (US). **GALDI, Vincenzo**; 1601 Willow Road, Menlo Park, California 94025 (US).

(54) Title: OBJECT DETECTION USING RF BEAT SIGNAL FREQUENCY AND PHASE

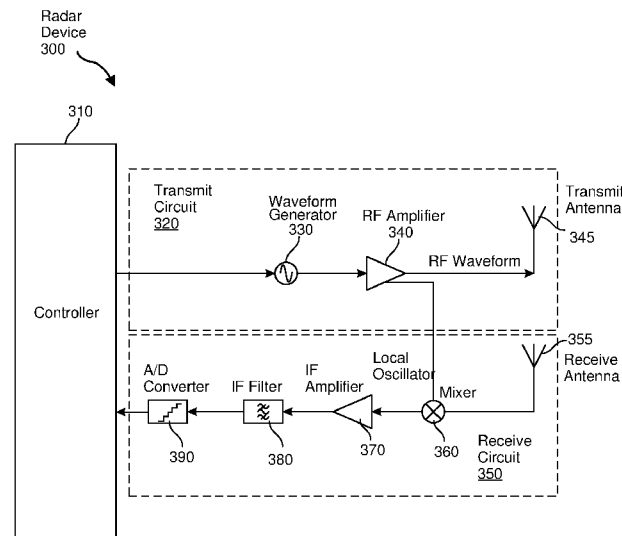

FIG. 3

(57) Abstract: An example device may include a transmitter, such as a radio-frequency (RF) transmitter, a receiver and a controller. The receiver may include a mixer that generates a beat signal from a received signal and a local oscillator signal. A transmitted signal may include a linear frequency ramp and may be incident on an object, inducing the received signal. The device may include a controller configured to detect a frequency and phase of the beat signal. The device may determine an absolute distance to the object using the beat frequency and a distance component using the beat signal phase. The distance component may be used to increase the precision of an object distance measurement relative to the absolute distance alone. The distance component may be used to detect relatively small movements of the object, such as micron-scale movements. Various other methods, systems and computer-readable media are also disclosed.



(74) **Agent:** COLBY, Steven et al.; Rimon Law, 420 West Main Street, Suite 101B, Boise, Idaho 83702 (US).

(81) **Designated States** (*unless otherwise indicated, for every kind of national protection available*): AE, AG, AL, AM, AO, AT, AU, AZ, BA, BB, BG, BH, BN, BR, BW, BY, BZ, CA, CH, CL, CN, CO, CR, CU, CZ, DE, DJ, DK, DM, DO, DZ, EC, EE, EG, ES, FI, GB, GD, GE, GH, GM, GT, HN, HR, HU, ID, IL, IN, IR, IS, IT, JO, JP, KE, KG, KH, KN, KP, KR, KW, KZ, LA, LC, LK, LR, LS, LU, LY, MA, MD, ME, MG, MK, MN, MW, MX, MY, MZ, NA, NG, NI, NO, NZ, OM, PA, PE, PG, PH, PL, PT, QA, RO, RS, RU, RW, SA, SC, SD, SE, SG, SK, SL, ST, SV, SY, TH, TJ, TM, TN, TR, TT, TZ, UA, UG, US, UZ, VC, VN, WS, ZA, ZM, ZW.

(84) **Designated States** (*unless otherwise indicated, for every kind of regional protection available*): ARIPO (BW, GH, GM, KE, LR, LS, MW, MZ, NA, RW, SD, SL, ST, SZ, TZ, UG, ZM, ZW), Eurasian (AM, AZ, BY, KG, KZ, RU, TJ, TM), European (AL, AT, BE, BG, CH, CY, CZ, DE, DK, EE, ES, FI, FR, GB, GR, HR, HU, IE, IS, IT, LT, LU, LV, MC, MK, MT, NL, NO, PL, PT, RO, RS, SE, SI, SK, SM, TR), OAPI (BF, BJ, CF, CG, CI, CM, GA, GN, GQ, GW, KM, ML, MR, NE, SN, TD, TG).

Published:

- with international search report (Art. 21(3))
- before the expiration of the time limit for amending the claims and to be republished in the event of receipt of amendments (Rule 48.2(h))

(88) **Date of publication of the international search report:**
21 July 2022 (21.07.2022)

INTERNATIONAL SEARCH REPORT

International application No
PCT/US2021/062263

A. CLASSIFICATION OF SUBJECT MATTER INV. G01S7/41 G01S13/34 G01S13/38 G01S13/88 G01S13/84 G01S13/36 G01S13/536 ADD. G01S13/87 According to International Patent Classification (IPC) or to both national classification and IPC				
B. FIELDS SEARCHED Minimum documentation searched (classification system followed by classification symbols) G01S Documentation searched other than minimum documentation to the extent that such documents are included in the fields searched Electronic data base consulted during the international search (name of data base and, where practicable, search terms used) EPO-Internal, WPI Data				
C. DOCUMENTS CONSIDERED TO BE RELEVANT				
Category*	Citation of document, with indication, where appropriate, of the relevant passages	Relevant to claim No.		
X	WO 97/01107 A1 (MROSIK JAN MICHAEL [DE]; NAGEL JOERG [DE]; STOJANOFF CHRISTO G [DE]) 9 January 1997 (1997-01-09)	1-9		
Y	page 1, line 2 - page 13, column 16; figure 1	9		
X	WOODS G S ET AL: "A HIGH ACCURACY MICROWAVE RANGING SYSTEM FOR INDUSTRIAL APPLICATIONS", IEEE TRANSACTIONS ON INSTRUMENTATION AND MEASUREMENT, IEEE, USA, vol. 42, no. 4, 1 August 1993 (1993-08-01), pages 812-816, XP000399896, ISSN: 0018-9456, DOI: 10.1109/19.234490	1-9		
Y	page 812 - page 815; figures 1-3	9		
Y	JP S60 44882 A (TOKYO KEIKI KK) 11 March 1985 (1985-03-11) the whole document	9		
<input type="checkbox"/> Further documents are listed in the continuation of Box C. <input checked="" type="checkbox"/> See patent family annex.				
* Special categories of cited documents : <table style="width: 100%; border: none;"> <tr> <td style="width: 50%; border: none; vertical-align: top;"> "A" document defining the general state of the art which is not considered to be of particular relevance "E" earlier application or patent but published on or after the international filing date "L" document which may throw doubts on priority claim(s) or which is cited to establish the publication date of another citation or other special reason (as specified) "O" document referring to an oral disclosure, use, exhibition or other means "P" document published prior to the international filing date but later than the priority date claimed </td> <td style="width: 50%; border: none; vertical-align: top;"> "T" later document published after the international filing date or priority date and not in conflict with the application but cited to understand the principle or theory underlying the invention "X" document of particular relevance; the claimed invention cannot be considered novel or cannot be considered to involve an inventive step when the document is taken alone "Y" document of particular relevance; the claimed invention cannot be considered to involve an inventive step when the document is combined with one or more other such documents, such combination being obvious to a person skilled in the art "&" document member of the same patent family </td> </tr> </table>			"A" document defining the general state of the art which is not considered to be of particular relevance "E" earlier application or patent but published on or after the international filing date "L" document which may throw doubts on priority claim(s) or which is cited to establish the publication date of another citation or other special reason (as specified) "O" document referring to an oral disclosure, use, exhibition or other means "P" document published prior to the international filing date but later than the priority date claimed	"T" later document published after the international filing date or priority date and not in conflict with the application but cited to understand the principle or theory underlying the invention "X" document of particular relevance; the claimed invention cannot be considered novel or cannot be considered to involve an inventive step when the document is taken alone "Y" document of particular relevance; the claimed invention cannot be considered to involve an inventive step when the document is combined with one or more other such documents, such combination being obvious to a person skilled in the art "&" document member of the same patent family
"A" document defining the general state of the art which is not considered to be of particular relevance "E" earlier application or patent but published on or after the international filing date "L" document which may throw doubts on priority claim(s) or which is cited to establish the publication date of another citation or other special reason (as specified) "O" document referring to an oral disclosure, use, exhibition or other means "P" document published prior to the international filing date but later than the priority date claimed	"T" later document published after the international filing date or priority date and not in conflict with the application but cited to understand the principle or theory underlying the invention "X" document of particular relevance; the claimed invention cannot be considered novel or cannot be considered to involve an inventive step when the document is taken alone "Y" document of particular relevance; the claimed invention cannot be considered to involve an inventive step when the document is combined with one or more other such documents, such combination being obvious to a person skilled in the art "&" document member of the same patent family			
Date of the actual completion of the international search	Date of mailing of the international search report			
30 March 2022	01/06/2022			
Name and mailing address of the ISA/ European Patent Office, P.B. 5818 Patentlaan 2 NL - 2280 HV Rijswijk Tel. (+31-70) 340-2040, Fax: (+31-70) 340-3016	Authorized officer Schmelz, Christian			

INTERNATIONAL SEARCH REPORT

International application No.
PCT/US2021/062263

Box No. II Observations where certain claims were found unsearchable (Continuation of item 2 of first sheet)

This international search report has not been established in respect of certain claims under Article 17(2)(a) for the following reasons:

1. Claims Nos.:
because they relate to subject matter not required to be searched by this Authority, namely:

2. Claims Nos.:
because they relate to parts of the international application that do not comply with the prescribed requirements to such an extent that no meaningful international search can be carried out, specifically:

3. Claims Nos.:
because they are dependent claims and are not drafted in accordance with the second and third sentences of Rule 6.4(a).

Box No. III Observations where unity of invention is lacking (Continuation of item 3 of first sheet)

This International Searching Authority found multiple inventions in this international application, as follows:

see additional sheet

1. As all required additional search fees were timely paid by the applicant, this international search report covers all searchable claims.

2. As all searchable claims could be searched without effort justifying an additional fees, this Authority did not invite payment of additional fees.

3. As only some of the required additional search fees were timely paid by the applicant, this international search report covers only those claims for which fees were paid, specifically claims Nos.:

4. No required additional search fees were timely paid by the applicant. Consequently, this international search report is restricted to the invention first mentioned in the claims;; it is covered by claims Nos.:

1-9

Remark on Protest

- The additional search fees were accompanied by the applicant's protest and, where applicable, the payment of a protest fee.
- The additional search fees were accompanied by the applicant's protest but the applicable protest fee was not paid within the time limit specified in the invitation.
- No protest accompanied the payment of additional search fees.

FURTHER INFORMATION CONTINUED FROM PCT/ISA/ 210

This International Searching Authority found multiple (groups of) inventions in this international application, as follows:

1. claims: 1-9

RF signal transmitter/receiver using LFMCW-frequency difference signal combined with Tx/Rx-phase difference (G01S13/343, G01S13/36) to obtain an absolute (unambiguous) high resolution distance measurement (= problem solved by the common matter of claim 1).

Problem solved (by the feature of searched claim 9, i.e. the beat frequency determined based on a time interval between the 'threshold crossings' or 'zero crossings' of the beat signal): alternative or simple detection of the difference frequency.

2. claim: 10

Plurality of transmitters and the (single) receiver (of claim 1) to determine a plurality of object distances (multi-static approach; G01S13/878).

Problem solved: e.g. to detect the orientation or shape of the (real) object.

3. claim: 11

The device includes a headset and the transmitter is located on said headset (preferably as component of a virtual reality system).

Problem solved: measuring a headset's distance from the virtual object location.

4. claims: 12, 13

Method for locating a transponder associated with an object (G01S13/84).

Problem solved: to improve the signal-to-noise of the received signal (see application, [0096]).

5. claims: 14, 15

RF signal transmitter/receiver transmitting a LFMCW-signal and measuring the with phase of the beat signal to obtain an object's movement (Doppler CW-detection; G01S13/536; no difference frequency and no distance determined).

Problem solved: measurement of object movement.

INTERNATIONAL SEARCH REPORT

Information on patent family members

International application No

PCT/US2021/062263

Patent document cited in search report		Publication date		Patent family member(s)		Publication date
WO 9701107	A1	09-01-1997	CN	1187882 A		15-07-1998
			DE	19521771 A1		02-01-1997
			EP	0834086 A1		08-04-1998
			JP	H11508046 A		13-07-1999
			US	6040898 A		21-03-2000
			WO	9701107 A1		09-01-1997

JP S6044882	A	11-03-1985	JP	H0116394 B2		24-03-1989
			JP	S6044882 A		11-03-1985
