

19



Europäisches Patentamt
European Patent Office
Office européen des brevets



11 Publication number:

0 218 325 B1

12

EUROPEAN PATENT SPECIFICATION

45 Date of publication of patent specification: **11.11.92** 51 Int. Cl.⁵: **H01R 13/115**

21 Application number: **86305918.4**

22 Date of filing: **01.08.86**

54 **Pin-receiving terminal.**

30 Priority: **30.09.85 US 781838**

43 Date of publication of application:
15.04.87 Bulletin 87/16

45 Publication of the grant of the patent:
11.11.92 Bulletin 92/46

84 Designated Contracting States:
DE FR GB

56 References cited:
EP-A- 0 060 024
FR-A- 2 018 767
US-A- 3 188 606

73 Proprietor: **MOLEX INCORPORATED**
2222 Wellington Court
Lisle Illinois 60532(US)

72 Inventor: **Triner, Irvin R.**
4223 S. Home
Stickney Illinois(US)

74 Representative: **Slight, Geoffrey Charles et al**
Graham Watt & Co. Riverhead
Sevenoaks Kent TN13 2BN(GB)

EP 0 218 325 B1

Note: Within nine months from the publication of the mention of the grant of the European patent, any person may give notice to the European Patent Office of opposition to the European patent granted. Notice of opposition shall be filed in a written reasoned statement. It shall not be deemed to have been filed until the opposition fee has been paid (Art. 99(1) European patent convention).

Description

BACKGROUND OF THE INVENTION

1. Field of the Invention

The present invention pertains to pin-receiving terminals.

2. Brief Description of the Prior Art

Several problems have been encountered in providing pin-receiving terminals for miniaturized electronic and electrical equipment. In the field of electrical connectors, miniaturization requires reduced center line spacings (progression) between terminal positions in a connector. For economy of manufacture, original equipment suppliers of electrical connectors prefer to gang-load terminals in a continuous side-by-side array, while joined to a common carrier member. It is therefore preferable that the terminal spacing on the carrier be the same as required in the connector housing.

Particular problems have been encountered when the required terminal centerline spacing falls below 0.100 inches (0.254 cm), principally since there is an insufficient amount of space on the metal blank with which to form a side-by-side array of terminals. An example of this problem can be seen in conventional box-type terminals, which receive a pin conductor within a structure having four sidewalls defining an enclosed pin-receiving region. When these terminals are placed side-by-side on a common carrier with aligned pin-receiving portions, the four-sidewall, unfolded blanks for each terminal must lie between adjacent terminal centerlines. Centerline spacings of about 0.1 inches (0.254 cm), cannot accommodate box-type terminals mateable with standard-sized pin terminals.

One advantage of box-type terminals is that a high spring rate can be obtained in repeated cycles, over a range of deflections in which the terminal is not overstressed so as to set or deform. However, for the reasons set forth above, other means must be utilized to achieve a high spring rate and workable deflection range in close centerline-spaced terminal arrangements. One common alternative, preloading of the terminal mating portions by partially stressing them before mating, requires a specially designed housing with relatively strict tolerances.

Single-cantilevered spring fingers (those having a free end) are a preferred pin-mating design, due to their simple construction. However, for a given terminal size (i.e., centerline spacing) higher spring rates require higher tolerances in the metal stamping and forming operations. Most notable among the tolerances is the gap width and the cross

sectional dimension of the pin-receiving region of the terminal. Too small of a gap leads to increased insertion forces, and increases the risk of terminal overstress, with deflection beyond its plastic deformation limit. Too large a gap causes insufficient mating forces.

Terminal designs are also affected by other application requirements. For example, some connectors must be cycleable, i.e. capable of mating and unmating many times over their useful life. This high cycleability requirement is economically satisfied by low insertion force connectors which minimally degrade a mating pin surface. With withdrawal forces being directly related to mating pressure, low insertion force requirements are met in low ratios of insertion-to-withdrawal forces.

EP-A-0191539 [which falls within the scope of Article 54(3) EPC] discloses a pin-receiving terminal having a pin mating forward portion which is U-shaped and has legs from which a pair of cantilever spring fingers extend inwardly towards a rear portion.

FR-A-2108767 also discloses a pin-receiving electrical terminal.

SUMMARY OF THE INVENTION

Accordingly, it is a principle object of the present invention to provide an improved pin-receiving terminal having a workable minimum mating force a minimum spring rate and a low insertion, withdrawal force ratio, but which can be stamped from a metal blank of narrow or reduced width.

The present invention provides a pin-receiving electrical terminal including a forward pin mating portion joined to a rear portion, the pin mating portion having a body section with a pair of opposed cantilever spring fingers extending inwardly therefrom and from a forward end of the body section toward the rear portion, with free ends adjacent the rear portion for imparting a mating force to a pin conductor received in a pin-receiving region defined therebetween, and in which said body section includes a resilient U-shaped member at the forward end thereof through which a pin conductor is to be received into the pin-receiving region, said U-shaped member having a curved base portion joining opposed legs resiliently deflectable relative to one another via the curved base portion to accommodate different-sized pin conductors therethrough, connecting means joining the opposed legs to the rear portion independently of the spring fingers, the connecting means defining an opening between the base of the U-shaped member and the rear section, and said spring fingers extend from said legs so that the free ends thereof generally move independently of the legs,

whereby when a pin conductor is received in the pin receiving region, the free ends of the spring fingers are deflected, developing a force on the pin conductor, the deflection of the spring fingers moving opposed legs of the U-shaped member apart thereby developing an additional force which is applied to the pin conductor via the free ends of the spring fingers.

Another object of the present invention is to provide a pin-receiving terminal of the above-described type in a terminal which is stamped and formed with a minimum number of low tolerance operations so as to have a single-cantilevered pin mating portion.

Still another object of the present invention is to provide a pin-receiving terminal of the above-described type suitable for close centerline spacing on a common carrier, which provides a minimum ratio of insertion to withdrawal forces, while providing an acceptable minimum spring rate and normal force.

Yet another object of the present invention is to provide a terminal of the above-described type which does not require preloading, and hence does not require specially-configured housings for mounting the terminal.

Some ways of carrying out the present invention will now be described by way of example with reference to drawings which show two specific embodiments.

In the drawings, wherein like elements are referenced alike,

FIG. 1 is a perspective view of a plurality of terminals of the present invention shown attached to a common carrier strip;

FIG. 2 is a cross-section of a terminal taken along the lines 2-2 of FIG. 1;

FIG. 3 is a cross-section view of a terminal taken along the line 3-3 of FIG. 1; and

FIG. 4 is a perspective view of a further embodiment to the terminal of FIGS. 1-3.

DETAILED DESCRIPTION OF THE ILLUSTRATED EMBODIMENTS

Referring now to FIG. 1, a plurality of terminals 10 according to the present invention are shown connected to a common carrier 12. Terminals 10 are arranged in side-by-side arrangement with a predetermined progression, ready for mass insertion in a connector having a corresponding number of similarly-spaced, side-by-side terminal receiving cavities. Terminals 10 and carrier 12 are formed from an integral metallic stamped blank to have a forward pin-mating body section 16, a rear portion 18 and a remote part 20. In the present embodiment, rear portion 18 provides a transition between the pin-mating body section 16 and the remote part

20 which is shown as a pin-like mating portion. The present invention, however, is concerned primarily with body section 16 and rear portion 18, and is independent of the particular configuration of any remote part 20 that may be present. For example, part 20 could be omitted with rear portion 18 including a crimp termination portion or an insulation displacing portion as are known in the art.

Terminal 10 has a forward pin mating portion comprising a body section 16 having a forward end 24. A pair of opposed single-cantilever spring fingers 26 are struck inwardly from body section 16 to extend from the forward end 24 toward rear portion 18. Fingers 26 terminate in free ends 28, adjacent rear portion 18, and include camming surfaces 30 for wiping engagement with a mating pin terminal 32, which is partially shown in the lefthand portion of FIG. 1. When fully mated, pin 32 is received in a pin-receiving region 44 formed between fingers 26 and particularly the camming surfaces 30 thereof.

The body section 16 includes a resilient U-shaped member 36 formed at forward end 24. Fingers 26 are integrally joined to the legs 38 of U-shaped member to receive cantilever support therefrom. Legs 38 are resiliently deflectable toward and away from each other, to accommodate different-size pin conductors 32, as will be explained later in greater detail.

The U-shaped member 36 is joined to rear portion 18 independently of spring fingers 26, by a pair of spaced-apart arms 40 which are joined at their forward end to the U-shaped member 36 (adjacent the bight portion thereof) and at their rearward end to rear portion 18. The pair of arms 40 are conveniently formed by punching a slot 42 in body section 16. As can be seen in FIG. 1, leg portions 38 are arranged coplanar with adjacent vertical sidewalls 43 of rear portion 18, with the free ends 28 of cantilever spring fingers struck inwardly therefrom. Arms 40 are positioned on the curved bight portion of the U-shaped member 36, at a point immediately adjacent the relatively straight leg portions 38. As a result, each arm 40 is generally coplanar with its adjacent spring finger 26.

In the present embodiment, rear portion 18 is conveniently formed with the same cross-sectional shape of body section 16. Consequently, the legs 38 of U-shaped member 36 are generally coplanar with the sidewalls 43 of rear portion 18. As will be readily appreciated by those skilled in the art, rear portion 18 need not have a U-shape in cross section, but rather, may have any convenient shape desired. Further, rear portion 18 can be larger or smaller in cross-section than body section 16.

Referring now to FIGS. 1, 2 and 3, operation of the terminal will be described. FIG. 2 is an end

view of the terminal of FIG. 1, as would be seen by a mating pin conductor. The pin receiving region 44 formed between spring fingers 26 and U-shaped member 36 has a minimum width W formed between camming surfaces 30. Terminal 10 is dimensioned such that width W is slightly less than the corresponding cross-sectional dimension of a mating pin terminal. Accordingly, when mated with a pin terminal, the free ends 28 of spring fingers 26 are outwardly deflected, with the extent of deflection over which the spring rate is developed, being generally termed the "working range" of the terminal. It is important in terminal operation, that the resilient mating members (herein, fingers 26) not be overstressed or deformed throughout their working range. Once the spring fingers 26 are spread apart a sufficient amount, further mating causes legs 38 to be spread apart, or outwardly resiliently deflected with respect to the bight portion of member 36, as indicated by arrows 48. Thus, introduction of a pin conductor 32 of sufficient size first exerts a lateral force in the direction of arrows 50 sufficient to deflect the free ends of fingers 26, and thereafter the outward deflection force is transmitted through arms 26 to their rear end portions, to cause outward resilient deflection of U-shaped member 36. This latter deflection of member 36 creates a resilient spring force which is coupled with the spring forces of fingers 26.

Sufficient outward deflection of U-shaped member 36 causes torsional arms 40 to resiliently rotate in the direction of arrows 54. Arms 40 are torsionally resilient, and their resilient bias force is coupled to the bias forces of U-shaped member 36, and spring fingers 26. This three-way coupling of resilient bias forces provides an increased working range not capable with prior art terminals. That is, at the upper end of a range of pin sizes (and/or the lower end of the range of widths W) the free ends 28 of fingers 26 are deflected approximately the same constant amount with respect to the fixed cantilevered ends adjacent legs 38. With a constant deflection being maintained, any tendency to overstress or otherwise deform spring fingers 26 is precluded, owing to the additional spring effects of U-shaped member 36 and, optionally, torsional arms 40.

The spring rate of torsional arms 40 can be adjusted over a wide range of values relative to the spring rate of U-shaped member 36, by a judicious choice of length, cross-sectional area and shape, as well as a choice of materials for arms 40. The spring rate of member 36 can be adjusted by the thickness of the metal blank, the width of the axially extending strapped portion of member 36 formed by slot 42. As will be appreciated, the added resilient bias force of U-shaped member 36 may alone be enough to prevent overstress of

fingers 26.

The spring fingers 26 extend in the direction of pin insertion toward their free ends 28. Preferably, spring fingers 26 and arms 40 are conveniently formed by slitting the common elongated portion of body section 16, to position fingers 26 and arms 40 immediately adjacent to each other. In this way, arms 40 are generally coplanar with spring fingers 26 to provide the desired enhanced working range.

Referring now to FIG. 4, a further embodiment of the present invention is shown in a terminal 110 substantially identical to the terminal of FIGS. 1 to 3, except for the modified body section 116. The modified body section 116 is substantially identical to section 16 of FIGS. 1 to 3, but for an additional axially-extending strap 150 extending between the legs 138 of the forward U-shaped member 136 and rear portion 18. Strap 150 provides an enhanced resistance to U-shaped member 136 against outward bowing of the open end of the U-shaped cross section. Although the torsional deflection of strap 150 is not as great as that of arm 40, torsional resilience of strap 150 can be relied upon for further improvements of the type described above. Alternatively, strap 150 can be configured to provide a resilient bending force which is coupled to the resilient spring force of fingers 26, to U-shaped member 136 and optionally to arm portions 40.

From any of the embodiments described above, it can be seen that a pin-receiving terminal of the present invention provides a high minimum contact pressure (or normal force) and spring rate in a blank of narrow or reduced width (i.e., blanks arranged on a common closely-spaced reduced center-line progression such as 0.100 inches (0.254 cm) or less). A terminal of the present invention further provides an improved low insertion/withdrawal ratio in a terminal having a high spring rate. The terminal of the present invention may also provide these features in a single-ended cantilever beam mating part which can be conveniently formed meeting the above requirements, with a minimum number of low tolerance metal working and metal forming operations. In particular, the present invention may provide a 300% improvement in combined pin cross-section dimension and gap width (W) tolerances. The spring fingers 26 of the illustrated embodiments undergo a relatively constant minimum deflection over a wide range of pin and pin-receiving region tolerances, while achieving a minimally acceptable contact normal force. These combined features are provided in a single-ended cantilever beam, without preloading.

Compact, close centerline-spaced terminals have been described with reference to the drawings with operating parameters of the above type heretofore available only in larger, more massive

terminal arrangements. The terminals may be stamped and formed with a minimum number of low tolerance operations so as to have a single-cantilevered pin mating portion. The terminals are suitable for close centerline spacing on a common carrier and provide a minimum rasion of insertion to withdrawal forces, while providing an acceptable minimum spring rate and normal force. The terminals do not require pre-loading, and hence do not require specially-configured housings for mounting them.

Claims

1. A pin-receiving electrical terminal (10) including a forward pin mating portion (16) joined to a rear portion (18), the pin mating portion (16) having a body section with a pair of opposed cantilever spring fingers (26) extending inwardly therefrom and from a forward end (24) of the body section toward the rear portion (18), with free ends (28) adjacent the rear portion for imparting a mating force to a pin conductor (32) received in a pin receiving region (44) defined therebetween, and in which

said body section includes a resilient U-shaped member (36, 136) at the forward end (24) thereof through which a pin conductor (32) is to be received into the pin-receiving region (44), said U-shaped member having a curved base portion joining opposed legs (38; 138) resiliently deflectable relative to one another via the curved base portion to accommodate different-sized pin conductors therethrough,

connecting means (40) joining the opposed legs (38; 138) to the rear portion independently of the spring fingers, the connecting means defining an opening (42) between the base of the U-shaped member and the rear section, and

said spring fingers (26) extend from said legs (38; 138) so that the free ends thereof generally move independently of the legs,

whereby when a pin conductor (32) is received in the pin receiving region (44), the free ends of the spring fingers (26) are deflected, developing a force on the pin conductor, the deflection of the spring fingers (26) moving opposed legs of the U-shaped member apart thereby developing an additional force which is applied to the pin conductor via the free ends of the spring fingers.
2. The terminal of claim 1, wherein said connecting means (40) includes two spaced-apart arm portions which are torqued when the opposed legs of the U-shaped member are moved apart developing a force which is applied to the pin

connector via the legs and spring arms.

3. The terminal of claim 2, further comprising two spaced-apart resilient strap means (150) joining the U-shaped member (136) to said rear portion (18), each said spring finger (26) being positioned between one of said strap means (150) and one of said arm portions (40).

10 Patentansprüche

1. Stiftaufnehmender elektrischer Anschluß (10) mit einem vorderen Stiftverbindungsbereich (16), der mit einem rückwärtigen Bereich (18) vereinigt ist, wobei der Stiftverbindungsbereich (16) einen Rumpfteil mit einem Paar einander gegenüberliegender freier Federfinger (26) besitzt, die sich von diesem und von einem vorderen Ende (24) des Rumpfteils zum rückwärtigen Bereich (18) hin erstrecken, mit an den rückwärtigen Bereich angrenzenden freien Enden (28) zum Aufbringen einer Verbindungskraft auf einen in einer zwischen ihnen gebildeten Stiftaufnahmezone (44) aufgenommenen Leiterstift (32), und wobei

der Rumpfteil ein federndes U-Formteil (36,136) an seinem vorderen Ende (24) aufweist, durch das ein Leiterstift (32) in die Stiftaufnahmezone (44) einzubringen ist, und das U-Formteil einen gekrümmten Basisbereich besitzt, der einander gegenüberliegende Schenkel (38;138) vereinigt, die federnd relativ zueinander über den gekrümmten Basisbereich zur Aufnahme unterschiedlich bemessener Leiterstifte durch diese auseinanderbiegbar sind,

eine Verbindungseinrichtung (40) die einander gegenüberliegenden Schenkel (38;138) mit dem rückwärtigen Bereich unabhängig von den Federfingern verbindet, wobei die Verbindungseinrichtung eine Öffnung (42) zwischen der Basis des U-Formteils und dem rückwärtigen Teil bildet, und

die Federfinger (26) von den Schenkeln (38;138) ausgehen, so daß ihre freien Enden sich im allgemeinen unabhängig von den Schenkeln bewegen,

wodurch, wenn ein Leiterstift (32) in der Stiftaufnahmezone (44) eingesetzt wird, die freien Enden der Federfinger (26) unter Entwicklung einer Kraft auf den Leiterstift ausgelenkt werden und die Auslenkung der Federfinger (26) die einander gegenüberliegenden Schenkel des U-Formteils auseinanderbewegt, wodurch eine zusätzliche Kraft entwickelt wird, die über die freien Enden der Federfinger auf den Leiterstift ausgeübt wird.

2. Anschluß nach Anspruch 1, bei dem die Verbindungseinrichtung (40) zwei voneinander beabstandete Armbereiche aufweist, die verdreht werden, wenn die einander gegenüberliegenden Schenkel des U-Formteils unter Entwicklung einer Kraft auseinanderbewegt werden, die über die Schenkel und die Federarme auf den Verbinderstift ausgeübt wird. 5
3. Anschluß nach Anspruch 2, ferner mit zwei voneinander beabstandeten federnden Gurtteilen (150), die das U-Formteil (136) mit dem rückwärtigen Bereich (18) verbinden, wobei jeder Federfinger (26) zwischen einem der Gurtteile (150) und einem der Armbereiche (40) angeordnet ist. 10 15

Revendications

1. Borne électrique (10) destinée à recevoir une broche, comportant une partie antérieure (16) pour son accouplement avec une broche, laquelle est reliée à une partie postérieure (18), la partie (16) d'accouplement avec une broche comportant une section de corps pourvue d'une paire de doigts formant ressorts opposés (26), en porte-à-faux, s'étendent vers l'intérieur de cette section de corps et à partir d'une extrémité antérieure (24) de la section de corps en direction de la partie postérieure (18), les extrémités libres (28) des doigts étant voisines de la partie postérieure afin d'appliquer une force d'accouplement à une broche conductrice (32) logée dans une région (44) de réception de la broche, définie entre les extrémités libres des doigts, et dans laquelle la section de corps comporte, à son extrémité antérieure (24), un élément élastique (36, 136) en forme de U à travers lequel une broche conductrice (32) peut s'engager pour venir se loger dans la région (44) de réception d'une broche, cet élément en forme de U ayant une portion de base courbe reliant des branches opposées (38, 138) pouvant fléchir élastiquement l'une par rapport à l'autre, par l'intermédiaire de la portion de base courbe, afin d'accepter à travers lui des broches conductrices de différentes dimensions, un moyen de liaison (40) reliant les branches opposées (38; 138) à la partie arrière indépendamment des doigts formant ressorts, ce moyen de liaison définissant une ouverture (42) entre la base de l'élément en forme de U et la partie postérieure, et les doigts formant ressorts (26) s'étendent à partir des branches (38; 138) de telle façon que leurs extrémités libres se déplacent d'une manière générale indépendamment par rapport aux branches, si bien que, lorsqu'une broche 20 25 30 35 40 45 50 55
- conductrice (32) est engagée dans la région (44) de réception d'une broche, les extrémités libres des doigts formant ressorts (26) sont fléchies en produisant une force s'exerçant sur la broche conductrice, le flexion des doigts formant ressorts (26) provoquant un déplacement des branches opposées, en les éloignant l'une de l'autre, de l'élément en forme de U en produisant ainsi une force additionnelle qui est appliquée à la broche conductrice par l'intermédiaire des extrémités libres des doigts formant ressorts.
2. Borne suivant la revendication 1 caractérisée en ce que le moyen de liaison (40) comprend deux bras espacés l'un de l'autre qui sont soumis à une torsion lorsque les branches opposées de l'élément en forme de U sont écartées l'une de l'autre, en produisant une force qui est appliquée à la broche conductrice par l'intermédiaire des branches et des doigts formant ressorts.
3. Borne suivant la revendication 2 caractérisée en ce qu'elle comprend en outre deux bandes élastiques (150) espacées l'une de l'autre, reliant l'élément (136) en forme de U à la partie postérieure (18), chacun des doigts formant ressorts (26) se trouvant entre l'une des bandes (150) et l'un des bras (40).

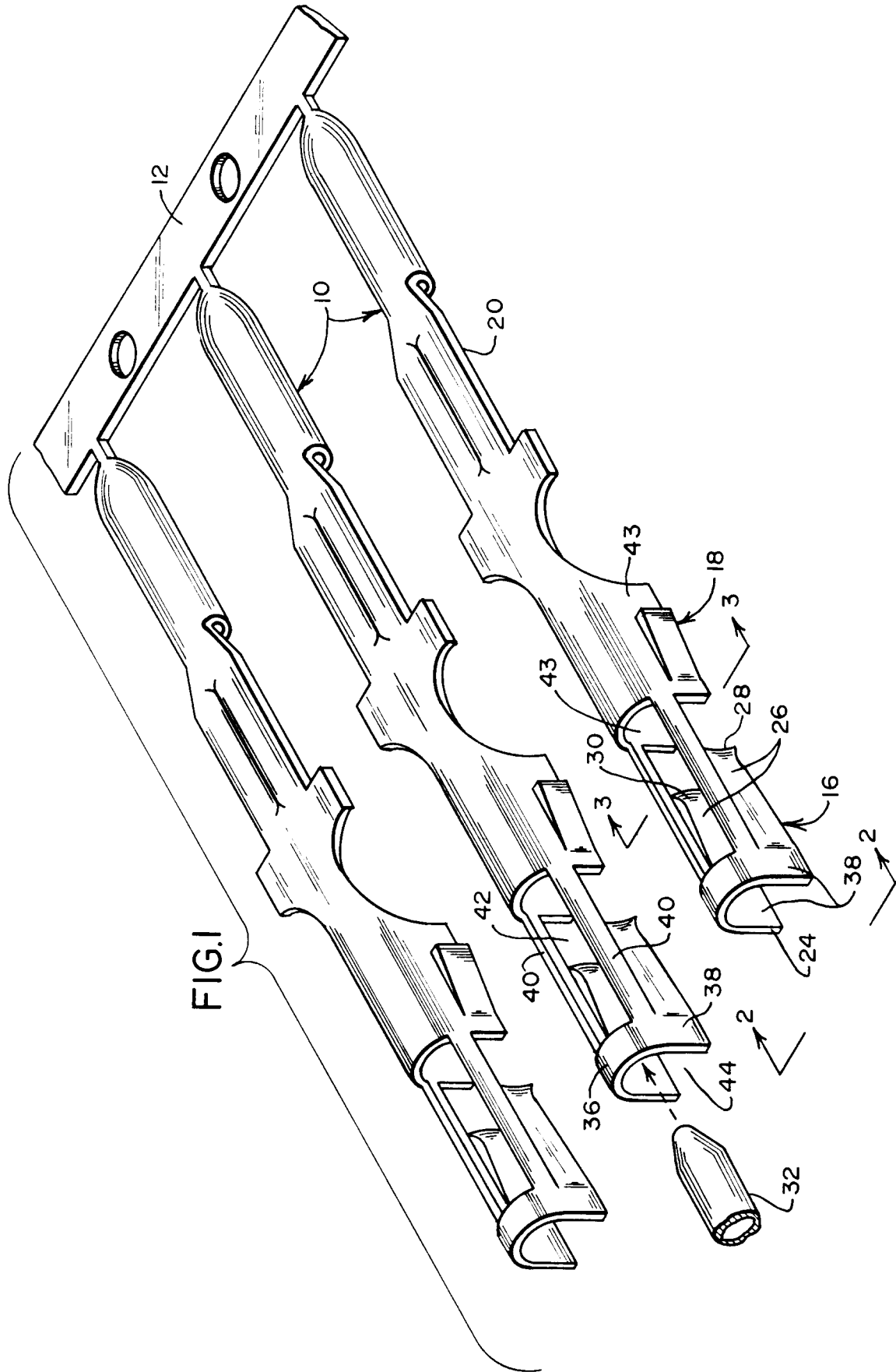

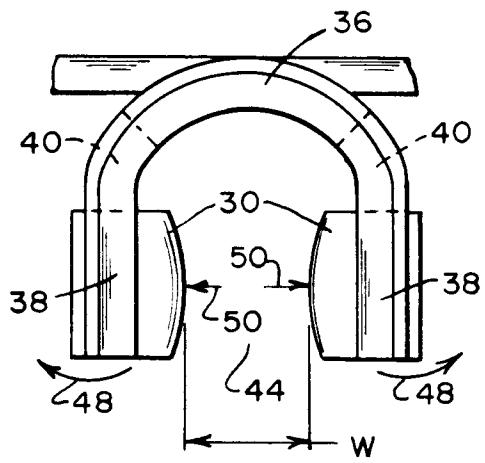

FIG. 2

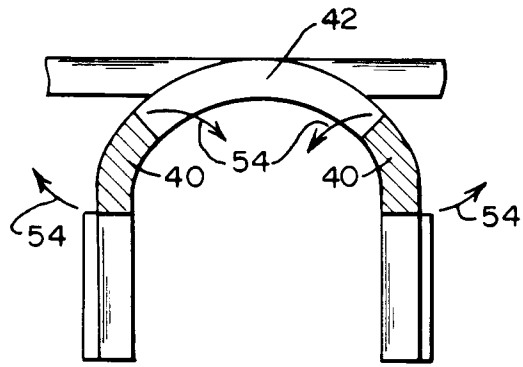

FIG. 3

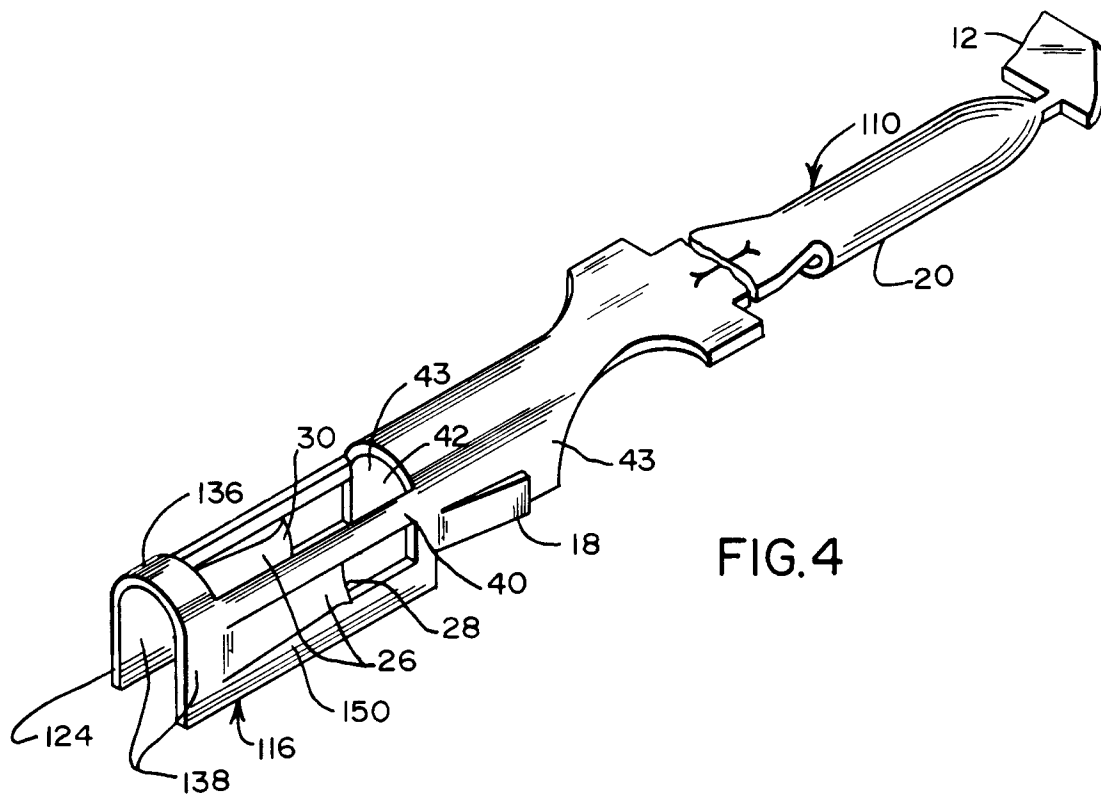

FIG. 4