

(19) World Intellectual Property Organization  
International Bureau



(43) International Publication Date  
10 January 2002 (10.01.2002)

PCT

(10) International Publication Number  
WO 02/03475 A1

(51) International Patent Classification<sup>7</sup>: H01L 31/02

(74) Agent: SHIGENO, Tsuyoshi; Nissin bldg., 9th floor, 5-10, Shinjuku 2-chome, Shinjuku-ku, Tokyo 160-0022 (JP).

(21) International Application Number: PCT/JP01/04832

(22) International Filing Date: 8 June 2001 (08.06.2001)

(81) Designated States (*national*): AE, AG, AL, AM, AT, AU, AZ, BA, BB, BG, BR, BY, BZ, CA, CH, CN, CO, CR, CU, CZ, DE, DK, DM, DZ, EC, EE, ES, FI, GB, GD, GE, GH, GM, HR, HU, ID, IL, IN, IS, KE, KG, KP, KR, KZ, LC, LK, LR, LS, LT, LU, LV, MA, MD, MG, MK, MN, MW, MX, MZ, NO, NZ, PL, PT, RO, RU, SD, SE, SG, SI, SK, SL, TJ, TM, TR, TT, TZ, UA, UG, US, UZ, VN, YU, ZA, ZW.

(25) Filing Language: English

(26) Publication Language: English

(30) Priority Data:  
2000-201201 3 July 2000 (03.07.2000) JP  
2000-201202 3 July 2000 (03.07.2000) JP

(84) Designated States (*regional*): ARIPO patent (GH, GM, KE, LS, MW, MZ, SD, SL, SZ, TZ, UG, ZW), Eurasian patent (AM, AZ, BY, KG, KZ, MD, RU, TJ, TM), European patent (AT, BE, CH, CY, DE, DK, ES, FI, FR, GB, GR, IE, IT, LU, MC, NL, PT, SE, TR), OAPI patent (BF, BJ, CF, CG, CI, CM, GA, GN, GW, ML, MR, NE, SN, TD, TG).

(71) Applicant (*for all designated States except US*): BRIDGE-STONE CORPORATION [JP/JP]; 10-1, Kyobashi 1-chome, Chuo-ku, Tokyo 104-8340 (JP).

(72) Inventors; and

(75) Inventors/Applicants (*for US only*): MIURA, Teruo [JP/JP]; 1-1, Ogawahigashi-cho 3-chome, Kodaira-shi, Tokyo 187-0031 (JP). AKUZAWA, Kazuyoshi [JP/JP]; 1-1, Ogawahigashi-cho 3-chome, Kodaira-shi, Tokyo 187-0031 (JP). MORIMURA, Yasuhiro [JP/JP]; 1-1, Ogawahigashi-cho 3-chome, Kodaira-shi, Tokyo 187-0031 (JP).

**Published:**

- with international search report
- before the expiration of the time limit for amending the claims and to be republished in the event of receipt of amendments

*For two-letter codes and other abbreviations, refer to the "Guidance Notes on Codes and Abbreviations" appearing at the beginning of each regular issue of the PCT Gazette.*

(54) Title: BACKSIDE COVERING MATERIAL FOR A SOLAR CELL MODULE AND ITS USE

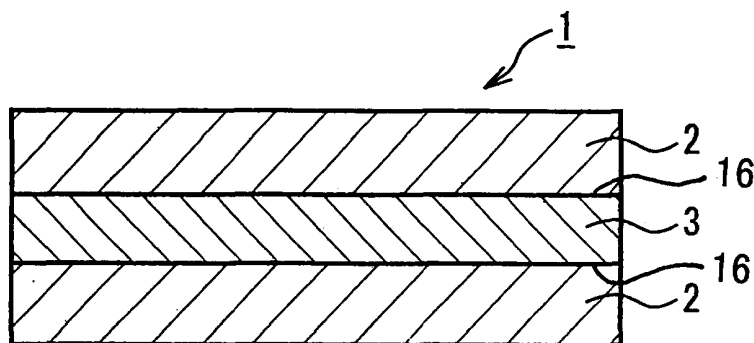

(57) Abstract: The present invention provides a light and thin backside covering material for a solar cell module which is excellent in moisture resistance and durability and is a good insulator without causing a short circuit with underlying wire nor leak current. Also the invention provides a durable and high performance solar cell module using this backside covering material as a rear surface protection member. The backside covering material for a solar cell module is a three-layer laminated

film, wherein a moisture resistant film (3) is sandwiched between two films (2) having heat resistance and weather resistance. A deposited layer (5) of inorganic oxide is formed on a surface of a base film (4) to make the moisture resistant film (3).



WO 02/03475 A1

## DESCRIPTION

### Backside covering material for a solar cell module and its use

#### Field of the Invention

The present invention relates to a backside covering material used for a rear surface protection member of a solar cell module and a solar cell module using said material. Particularly, it relates to the backside covering material for a solar cell module having excellent moisture resistance and durability and insulating very well to prevent leak current, and to a durable and high-performance solar cell module using the material as the rear surface protection member.

#### Background of the Invention

A solar cell module has been paid attention as a device directly converting solar energy into electric energy from the aspects of effective use of natural resources and ecology, and various solar cell modules have been developed.

As shown in Fig. 3, in a solar cell module, solar cells 14 (photovoltaic element made of silicon etc.) are sealed by ethylene-vinyl acetate copolymer (EVA) films 13A, 13B in between a transparent front surface (light receiving face) protection member 11 and a rear surface protection member (backside covering material) 12.

A solar cell module 10 is produced by the following procedures. First, a front surface protection member 11 made of glass or the like, EVA film 13A for

sealant, silicon photovoltaic element 14, EVA film 13B for sealant, and a backside covering material 12 are stacked up in this sequence. Then, EVA is melted by heat and cross-linked to unify the whole solar cell module.

A backside covering material is desired to be light and thin to make a solar cell module light and thin. The backside covering material is also desired to have durability in a long term since a solar cell module is usually installed outside. Further, the backside covering material needs to have high moisture resistance to prevent permeation of moisture and water causing rusting in underlying parts such as photovoltaic element, wire, and electrodes.

The conventional backside covering material is a laminated film comprising metal foil such as aluminum foil and galvanized iron foil as a moisture preventing layer put between two resin film layers.

However, there are several disadvantages associated with the conventional backside covering material using metal foil. First, a solar cell module using the conventional material sometimes has leak current. Second, projections of underlying parts such as a photovoltaic element and a wire may penetrate through a resin film to cause a short-circuit with metal foil. Third, a laminated resin film without including metal foil cannot give enough moisture resistance.

### **Summary of the Invention**

An object of this invention is to provide a backside covering material for a rear surface protection member of a solar cell module which doesn't have any disadvantages mentioned above, is light and thin, has improved moisture resistance

and durability, and also is a good insulator. Another object of this invention is to provide a solar cell module with high durability and performance using the backside covering material for a rear surface protection member.

The backside covering material for a solar cell module in this invention includes a moisture resistant film disposed between two films having heat resistance and weather resistance, wherein the moisture resistant film has a deposited layer of inorganic oxide on a surface of a base film.

The backside covering material of this invention is light and thin. The moisture resistant film having the base film and the deposited layer of inorganic oxide on the surface of the base film is highly moisture resistant and is an excellent insulator so that a short-circuit and leak current associated with underlying parts such as a photovoltaic element and a wire of a solar cell module is prevented.

Inorganic oxide used for the deposited layer of the moisture resistant film is preferably silicon oxide, most preferably  $\text{SiO}_x$ , where  $x$  is in a range of 1.7-1.9. The thickness of the deposited layer is preferably in a range of 100-500 Å.

An anchor coat layer may be formed between the base film and the deposited layer of inorganic oxide. The anchor coat layer ensures the prevention of moisture permeating through the backside covering material of a solar cell module for a long time. The anchor coat layer may be of acrylic urethane resin.

The backside covering material of a solar cell module of this invention may also have an adhesive layer on one surface thereof.

The backside covering material of a solar cell module of this invention may have moisture permeability not higher than  $1.0\text{g}/\text{m}^2/\text{day}$ .

In this invention, it is preferred to use hydrogenated polybutadiene-denatured urethane adhesive to bond the film having heat resistance and weather resistance and the moisture resistant film.

A solar cell module of this invention includes at least one solar cell, a front surface protection member and a rear surface protection member. The solar cell(s) is disposed between the front surface protection member and the rear surface protection member, and the solar cell(s) is sealed by the protection members. The rear surface protection member is made of the backside covering material of this invention.

### **Brief Description of the Drawings**

Fig. 1 is a cross-sectional view of an embodiment of this invention relating to a backside covering material for a solar cell module.

Fig. 2a is a cross-sectional view of a moisture resistant film.

Fig. 2b is a cross-sectional view of a moisture resistant film.

Fig. 3 is a cross-sectional view of a conventional solar cell module.

Fig. 4 is a cross-sectional view of an embodiment of a solar cell module using the backside covering material of this invention.

Fig. 5 is a cross-sectional view of another embodiment of a solar cell module using the backside covering material of this invention.

Fig. 6 is a cross-sectional view of an embodiment of a backside covering material working also as a sealant for a solar cell module.

## Detailed Descriptions of the Preferred Embodiments

Preferred embodiments of this invention will be described in detail with reference to drawings. The drawings represent just embodiments of the invention, and the invention is not limited to those drawings.

Fig. 1 is a cross-sectional view of a backside covering material for a solar cell module according to an embodiment of this invention and Fig. 2a is a cross-sectional view of a moisture resistant film of the backside covering material.

A backside covering material 1 in Fig. 1 is a laminated film including a moisture resistant film 3 disposed between two films 2, 2 having heat resistance and weather resistance. The films 2, 2, 3 are made integral to form the backside covering material 1.

The moisture resistant film 3 has, as shown in Fig. 2a, a base film 4 and a deposited layer 5 which is formed by depositing inorganic oxide on a surface of the base film by one of thin layer forming processes, for example, CVD (chemical vapor deposition) method, PVD (physical vapor deposition) method, and the like.

The deposited layer 5 of inorganic oxide works as a moisture resistance layer. The inorganic oxide is preferably aluminum oxide or silicon oxide. Silicon oxide is suitable because of its durability under hot and humid condition. A thickness of this deposited layer is preferably in a range of 100- 500 Å, most preferably 200-400 Å. It is preferable to use silicon oxide  $\text{SiO}_x$ , where x is in a range of 1.7-1.9, for the moisture resistance layer.

The base film 4 is required to endure heat and pressure during the manufacturing process of the solar cell module. The base film 4 can be made of

fluororesin such as polytetrafluoroethylene (PTFE), 4-fluoroethylene-perchloroalkoxy copolymer (PFA), 4-fluoroethylene-6-fluoropropylene copolymer (FEP), 2-ethylene-4-fluoroethylene copolymer (ETFE), poly3-chlorofluoroethylene (PCTFE), polyvinylidene fluoride (PVDF), and polyvinyl fluoride (PVF), polyester resin such as polyethylene terephthalate (PET), and other various resins such as polycarbonate, polymethyl methacrylate (PMMA), and polyamide. The base film may include two or more kinds of resins selected from those resins listed above, and may be a multi-layer film. If necessary, additives such as a pigment, an ultraviolet light absorber and so on may be added to the base film through permeation or coating or mixing. The thickness of the base film 4 is preferably in a range from 3 to 300 $\mu\text{m}$ , most preferably from 5 to 200 $\mu\text{m}$ .

As shown in Fig. 2b, an anchor coat layer 6 may be formed between the base film 4 and the deposited layer 5 of inorganic oxide to prevent moisture permeation for a long time. The anchor coat layer 6 ensures the long-term close adhesion between the deposited layer 5 and the base film 4, which allows an excellent moisture resistance of the moisture resistant film 3A.

The anchor coat layer 6 can be formed of acrylic resin, polyester resin, alkyd resin, urethane alkyd resin, polyamide resin, polyurethane resin, phenolic resin or the like. Among them, acrylic resin is preferable.

Examples of acrylic resin used for the anchor coat layer 6 include copolymer resins from esters (methyl methacrylate, butyl methacrylate, butyl acrylate, 2-hydroxyethyl acrylate, and the like) and comonomers (acrylic ester, acrylic acid, methacrylic acid and the like). When acrylic urethane resin is used for

the anchor coat layer 6, the moisture resistant film is considerably improved in preventing moisture permeation. Such acrylic urethane resin is prepared by introducing functional groups (carboxyl group, hydroxyl group, methylol group, glycidyl group, and the like) to side chains of those copolymers followed by cross-linking with aliphatic isocyanate, for example, tetramethylene diisocyanate, trimethylhexamethylene diisocyanate, and the like, or aromatic isocyanate, for example, tolylene diisocyanate (TDI), diphenylmethane diisocyanate (MDI), polymeric diphenylmethane diisocyanate (P-MDI), naphthalene diisocyanate (NDI), and the like.

The anchor coat layer 6 can be formed by painting the application liquid on the base film and drying up. The application liquid is desirable to be an aqueous solution.

A thickness of the anchor coat layer 6 is preferably in a range from 0.01 to 1 $\mu$ m.

Prior to form the anchor coat layer 6 the surface of the base film 4 may be processed by the corona treatment to improve close adhesion between the layer 6 and the film 4.

The moisture resistant film having improved moisture resistance and close adhesion with the deposited layer can be obtained by curing for more than 24 hours at 40-80°C after deposition of inorganic oxide onto the base film.

The backside covering material 1 of a solar cell module has a laminated three-layer structure. A middle layer is the moisture resistant film 3 or 3A disposed between two films 2, 2 having heat resistance and weather resistance.

The film 2 having heat resistance and weather resistance is required to endure heat and pressure during the manufacturing process of the solar cell module like the base film. Materials of the film 2 can be the same materials with that of the base film mentioned above. Also, similar to the base film, the film 2 having heat resistance and weather resistance can be made of two or more kinds of resins. The film 2 can be a composite laminating two or more films. If necessary, additives such as a pigment, an ultraviolet light absorber, a coupling agent and so on may be added to materials of the film having heat resistance and weather resistance through permeation or coating or mixing. A thickness of the film 2 is preferably in a range from 5 to 200 $\mu\text{m}$ .

A color of the film 2 having heat resistance and weather resistance is not particularly specified. While white color and the like are appropriate for improving efficiency of generating electricity, black and other dark colors are appropriate for a nice appearance when a solar cell module is installed at houses.

Two films 2, 2 having heat resistance and weather resistance putting the moisture resistant film between them are not necessarily made of the same materials

With respect to two films having heat resistance and weather resistance, one of two films placed outer side of a solar cell module is preferred to be made of fluororesin because of its high weather resistance, and the other film placed inner side of a solar cell module is preferred to be made of materials including a pigment and so on, that is, materials having reflectivity.

A method of manufacturing the backside covering material of this

invention may include the steps of: applying an adhesive 16 between the film 2 having heat resistance and weather resistance and the moisture resistant film 3 ; and bonding films by the dry lamination method or the heat press method to form a composite.

The adhesive 16 can be one of ordinary polyester or polyether adhesives. However, a polyether adhesive has low initial adhesion and sometimes has insufficient heat resistance. A polyester adhesive having high heat resistance sometimes has low heat -and- moisture resistance. These are caused by the fact that those adhesives have the chemical structure  $\text{—O—}$  or  $\text{—C=O—O—}$  in their main chains.

To overcome these disadvantages, a hydrogenated polybutadiene denatured urethane adhesive may be used to bond films 2, 2 and the moisture resistant film. The main chain of this adhesive is a butadiene structure and, further, the main chain is hydrogenated to prevent the degradation caused by breakage of double bonds. Because of the main chain constructed by the chemical structure  $\text{—CH}_2\text{—}$ , this adhesive shows a considerably improved durability in adhesion compared to conventional adhesives.

The backside covering material for a solar cell module may be unified with EVA film used as a sealant through the lamination. A thickness of EVA film is preferably in a range of 0.1-1mm.

Fig. 6 is a cross-sectional view of a backside covering material for a solar cell module unified with a sealant.

The backside covering material unified with the sealant 1' for a solar cell

module comprises two films having heat resistance and weather resistance 2, 2, the moisture resistant film 3 put in between two films 2, 2, and further, an adhesive layer 15 disposed adjacent to an outer surface of one of films 2, 2.

In the back side covering material unified with the sealant 1', the films having heat resistance and weather resistance are formed to protect the moisture resistant film 3 and to improve working efficiency in manufacturing solar cell modules. These films are also required to endure heat and pressure through manufacturing process of a solar cell module. Since one of these two films 2 placed on the opposite side of the adhesion layer 15 becomes an outermost layer of a solar cell module once assembled, the film 2 is required to withstand degradation in field use for an extended period of time.

The adhesion layer 15 works as a sealant of underlying parts such as photovoltaic element and other members and also as a cushioning material. That is, the adhesion layer is required to have good adhesion by the heat to bond and unify a transparent front surface protection member made of glass or the like, a conducting film made of metallic oxide such as ITO, and a silicon photovoltaic element. EVA resin, PVB resin or the like is usually used for the adhesion layer. Adhesive resins such as silicon resin, acrylic resin, butyl resin, and epoxy resin, can also be used for the adhesion layer. EVA adhesive resin is mostly used because of its handling efficiency and low cost. EVA resin composition used for this EVA adhesive resin will be detailed later.

A thickness of the adhesion layer 15 is preferably in a range of 0.1-1mm.

A solar cell module of this invention is composed of laminated layers

including the backside covering material 1 (or 1'), EVA sealing film 13B, at least one solar cell 14 made of silicon photovoltaic element or the like, EVA sealing film 13A, and the front surface protection member 11 made of glass or high-functioning laminated film. It is desirable that those layers are bonded by a vacuum laminator operating under the following heating and pressing condition: temperature 120-150°C; deaeration time for 2-15min; pressure 0.5-1atm; and pressing time for 8-45min.

In order to improve weather resistance it is preferred to add a cross-linking agent into EVA resin composition. The cross-linking agent is preferably chosen from organic peroxides generating radicals above 100°C, most preferably from organic peroxides having a half-life of 10 hours and a decomposition temperature above 70°C. Examples of those organic peroxides include 2,5-dimethylhexane; 2,5-dihydroperoxide, 2,5-dimethyl-2,5-di(tert-butylperoxy)hexane, 3-di-tert-butylperoxide, tert-dicumyl peroxide, 2,5-dimethyl-2,5-di(tert-butyl-peroxy)hexyne, dicumyl peroxide,  $\alpha, \alpha'$ -bis(tert-butylperoxyisopropyl)benzene, n-butyl-4,4-bis(tert-butyl-peroxy)butane, 2,2-bis(tert-butylperoxy)butane, 1,1-bis(tert-butylperoxy)cyclohexane, 1,1-bis(tert-butylperoxy)-3,3,5-trimethylcyclohexane, tert-butyl peroxybenzoate, and benzoyl peroxide. The amount of organic peroxide is preferably 5 parts by weight or less, most preferably 1-3 parts by weight, for 100 parts by weight of EVA resin composition.

A coupling agent made of silane compounds may be added into EVA resin composition to improve adhesion of EVA resin. Examples of silane coupling agent include  $\gamma$ -chloropropyltrimethoxysilane, vinyltrichlorosilane, vinyltriethoxysilane,

vinyl-tris-( $\beta$ -methoxyethoxy)silane,  $\gamma$ -methacryloxypropyltrimethoxysilane,  $\beta$ -(3,4-ethoxycyclohexyl)ethyltrimethoxysilane,  $\gamma$ -glycidoxypropyltrimethoxysilane, vinyltriacetoxysilane,  $\gamma$ -mercaptopropyltrimethoxysilane,  $\gamma$ -aminopropyltrimethoxysilane, and N- $\beta$ -(aminoethyl)- $\gamma$ -aminopropyltrimethoxysilane. The amount of the silane coupling agent is preferably 5 parts by weight or less, most preferably 0.1-2 parts by weight, for 100 parts by weight of EVA resin composition.

A crosslinker may be added into EVA resin composition to increase gel fraction of EVA resin, that is, to improve durability of EVA resin. The crosslinker can be a crosslinker having 3 functional groups such as triallyl isocyanurate and triallyl isocyanate, or having only one functional group such as NK ester. The amount of the crosslinker is preferably 10 parts by weight or less, most preferably 1-5 parts by weight, for 100 parts by weight of EVA resin composition.

EVA resin composition may include compound(s) such as hydroquinone, hydroquinone monomethyl ether, p-benzoquinone, and/or methylhydroquinone to improve the stability of EVA resin. The amount of such compound(s) is 5 parts by weight or less for 100 parts by weight of EVA resin composition.

Other additives, for example, colorant, ultraviolet light absorber, anti-aging agent, and discoloring inhibitor may be added into EVA resin composition. The colorant may be an inorganic pigment (metallic oxide, metallic powder, and the like) or an organic pigment (azo group, phthalocyanine group, azine group, acid lake, basic lake, or the like). Examples of the ultraviolet light absorber include

benzophenone such as 2-hydroxy-4-octoxybenzophenone and 2-hydroxy-4-methoxy-5-sulfobenzophenone, benzotriazole such as 2-(2'-hydroxy-5-methylphenyl)benzotriazole, and salicylate such as phenylsulicylate, p-t-butylphenyl sulicylate. With respect to an anti-aging agent, amine compounds, phenol compounds, bisphenyl compounds, and hindered amine compounds, for example, di-t-butyl-p-cresol and bis(2,2,6,6-tetramethyl-4-piperazyl)sebacate are used.

Besides EVA resin, PVB resin, silicon resin, acrylic resin, butyl resin, and epoxy resin can be used for sealing films 13A, 13B of this invention.

The backside covering material of this invention (Fig. 3) is applied to a bulk solar cell module using single crystal or polycrystal of silicon. Also, the backside covering material can be applied to a thin film solar cell module 20 using silicon film, II-VI compound (CdTe), chalcopyrite thin film (CIS), or organic semiconductor without making any changes in the material's structure as shown in Fig. 4, where glass 21, a transparent electrode 22, a thin film semiconductor 23, a metallic electrode 24, a sealant 25, and a back covering material 26 are shown. Further, the backside covering material can be applied to a flexible type of thin film solar cell module, in which a front surface protection member is made of transparent resin film instead of glass, as shown in Fig. 5, where a transparent resin film 31, a sealant 32, a thin film solar cell element 33, a base film 34, a sealant 35, and a backside covering material 36 are shown.

Hereinafter, the present invention will be described in detail with reference to examples and comparative examples.

## Examples 1 and 2

One of two films having heat resistance and weather resistance was made of polyester film mixed with a white pigment (U2, manufactured by Teijin-Du Pont Film, Co. Ltd., thickness: 38 $\mu$ m) and the other film was made of ETFE film (AFFLEX manufactured by Asahi Glass Co. Ltd., thickness: 21 $\mu$ m). After placing a moisture resistant film having a composition in Table 1 in between two films described above, those three films were bonded to make a backside covering material of this invention. The bonding was done through an ordinary dry lamination method at temperature 60-90°C with 3kg of nip pressure using an acrylic urethane adhesive applied with 10 $\mu$ m of thickness.

The backside covering materials made by the method described above have been through the endurance test, in which the materials were let stand for 1000 hours under a more harsh condition, at 85°C with 90%RH, than an ordinary endurance test condition, at 65°C with 95%RH. After the endurance test, the moisture permeability of the materials was measured by the MOCON method (at 40°C, 90%RH). The results are listed in Table 1.

## Comparative Example 1

A laminated film was formed by the same manner with Example 1, in which a middle layer of a transparent PET film (S-PET manufactured by Teijin-Du Pont Film, Co. Ltd., thickness: 50 $\mu$ m) was sandwiched with two white PVF films (TEDLER manufactured by Du Pont, Co. Ltd., thickness: 38 $\mu$ m). The film was tested by the same test with that in Example 1. The result is given in Table 1.

Table 1

		Examples		Comparative Example
		1	2	1
Composition of moisture resistant film	Base film (Thickness)	PET film (12 $\mu$ m)	PET film (12 $\mu$ m)	PVF/PET/PVF (38 $\mu$ m/50 $\mu$ m/38 $\mu$ m)
	Presence of anchor coat layer	No	Yes	
	Resin of anchor coat layer (Thickness)	—	Acrylic urethane resin(0.1 $\mu$ m)	
	Compound used for deposited layer (Thickness)	Silicon oxide (200 $\text{\AA}$ )	Silicon oxide (200 $\text{\AA}$ )	
Moisture permeability (g/m <sup>2</sup> /day)		3.7	0.2	5.5

As a result from Table 1, it has been found that the backside covering material of this invention is excellent in preventing moisture permeation and in durability.

### Example 3

One of two films having heat resistance and weather resistance was made of polyester film mixed with a white pigment (U2 manufactured by Teijin-Du Pont Film, Co. Ltd., thickness: 38 $\mu$ m) and the other film was made of ETFE film (AFFLEX manufactured by Asahi Glass, Co. Ltd., thickness: 21 $\mu$ m). A moisture resistant film was made by depositing SiO<sub>x</sub> (x=1.8) on a surface of PET film with 12 $\mu$ m of thickness to form a moisture resistance layer with 200  $\text{\AA}$  of thickness. The moisture resistant film was placed in between two films having heat resistance and weather resistance. These three films were bonded with an adhesive given in Table 2. Further EVA adhesive layer with 50 $\mu$ m of thickness was formed on the

outer surface of the polyester film to make a backside covering material working also as a sealant of this invention.

The obtained backside covering material unified with the sealant has been through an endurance test, in which the material was let stand for 1000 hours under a more harsh condition, at 85°C with 90%RH, than an ordinary endurance test condition, at 65°C with 95%RH. After the endurance test, moisture permeability of the material was measured by the MOCON method (at 40°C, 90%RH). Also, adhesion of the material was measured before and after the endurance test by the T-type adhesion test method. The results are given in Table 2.

#### Comparative example 2

A laminated film consisting of a transparent PET film (S-PET manufactured by Teijin-Du Pont Film, Co. Ltd., thickness: 50 $\mu$ m) sandwiched with two white PVF films (TEDLER manufactured by Du Pont, Co. Ltd., thickness: 38 $\mu$ m) was made in the same manner with Example 1. Moisture permeability and adhesion of the film were measured in the same manner with Example 3. The results are given in Table 2.

#### Comparative Examples 3 and 4

A backside covering material unified with a sealant was formed in the same manner with Example 3 except for using an adhesive given in Table 2 to bond films having heat resistance and weather resistance and the moisture resistant film.

Moisture permeability and adhesion of the films were measured in the same manner with Example 3. The results are given in Table 2.

Table 2

Example	Moisture resistant film	Adhesive	Moisture permeability (g/m <sup>2</sup> /day)	Adhesion (gf/25mm)	
				Before endurance test	After endurance test
Example 3	SiOx deposited layer	Hydrogenated polybutadiene denatured urethane	0.3	2100	1500
Comparative Example 2	PVF/PET/PVF	Polyurethane	5.5	2000	150
Comparative Example 3	SiOx deposited layer	Polyether	1.5	1700	300
Comparative Example 4	SiOx deposited layer	Polyester	3.6	2400	100

As a result from Table 2, it has been found that the backside covering material unified with the sealant of this invention is excellent in preventing moisture permeation, adhesion, and durability.

As detailed above, a backside covering material for a solar cell module of this invention is light, thin, and excellent in moisture resistance and durability. Further, the material doesn't have any problems associated with a short circuit or leak current. A solar cell module using this backside covering material as its rear surface protection member is free from rust, and has an excellent moisture resistance, a long-term durability, and no lowering of performance caused by a short circuit or leak current.

## CLAIMS

1. A backside covering material used for a rear surface protection member of a solar cell module including a moisture resistant film disposed in between two films having heat resistance and weather resistance, wherein said moisture resistant film has a base film and a deposited layer of inorganic oxide on the surface of the base film.
2. A backside covering material for a solar cell module as claimed in claim 1, wherein said inorganic oxide is silicon oxide.
3. A backside covering material for a solar cell module as claimed in claim 2, wherein silicon oxide is  $\text{SiO}_x$ , where x is in a range of 1.7-1.9.
4. A backside covering material for a solar cell module as claimed in any one of claims 1 through 3, wherein an anchor coat layer is formed between the base film and the deposited layer of inorganic oxide of said moisture resistant film.
5. A backside covering material for a solar cell module as claimed in claim 4, wherein said anchor coat layer is made of acrylic resin, polyester resin, alkyd resin, urethane alkyd resin, polyamide resin, polyurethane resin, or phenolic resin.
6. A backside covering material for a solar cell module as claimed in claim 4, wherein said anchor coat layer is made of acrylic urethane resin.
7. A backside covering material for a solar cell module as claimed in any one of claims 4 through 6, wherein a thickness of the anchor coat layer is in a range of 0.01-1 $\mu\text{m}$ .
8. A backside covering material for a solar cell module as claimed in any one

of claims 1 through 7, wherein a thickness of said deposited layer of inorganic oxide is in a range of 100-500Å.

9. A backside covering material for a solar cell module as claimed in any one of claims 1 through 8, wherein said base film includes at least one film made of substance selected from a group consisting of fluororesin, polyester, polycarbonate, polymethylmethacrylate, and polyamide.

10. A backside covering material for a solar cell module as claimed in any one of claims 1 through 9, wherein a thickness of the base film is in a range of 3-300µm, preferably in a range of 5-200µm.

11. A backside covering material for a solar cell module as claimed in any one of claims 1 through 10, wherein said film having heat resistance and weather resistance and the moisture resistant film are bonded with a hydrogenated polybutadiene denatured urethane adhesive.

12. A backside covering material for a solar cell module as claimed in any one of claims 1 through 11, wherein an adhesive layer is disposed adjacent to one surface of said backside covering material.

13. A backside covering material for a solar cell module as claimed in claim 12, wherein the adhesive layer is made of EVA resin, PVB resin, silicone resin, acrylic resin, butyl resin, or epoxy resin.

14. A backside covering material for a solar cell module as claimed in any one of claims 1 through 13, wherein moisture permeability of said backside covering material is 1.0g/m<sup>2</sup>/day or less.

15. A solar cell module comprising:

at least one solar cell; and

a front surface protection member and a rear surface protection member  
putting said at least one solar cell there between:

said rear surface protection member being the backside covering material  
for a solar cell module described in any one of claims 1 through 14.

Fig. 1

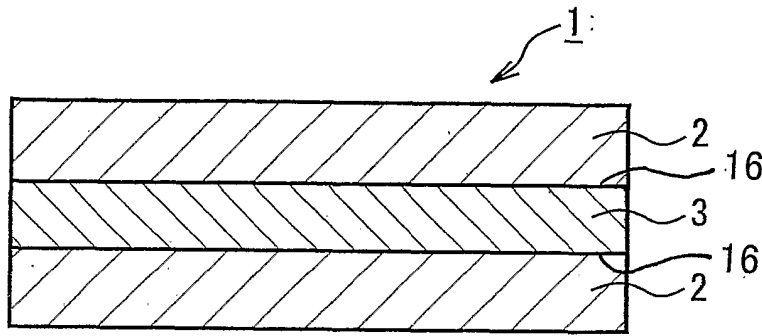

Fig. 2a

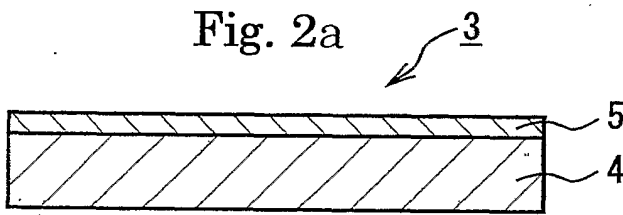

Fig. 2b

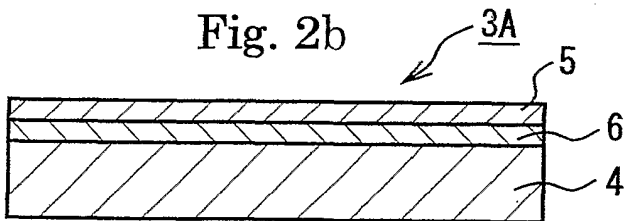

Fig. 3

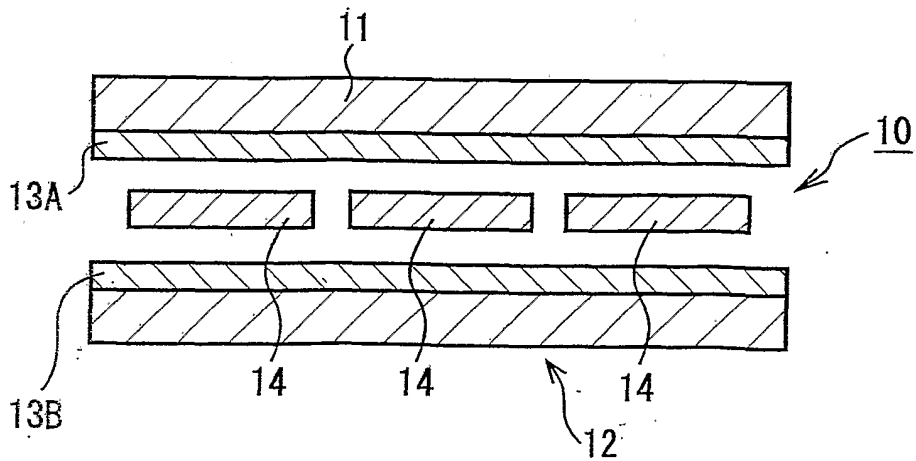

Fig. 4

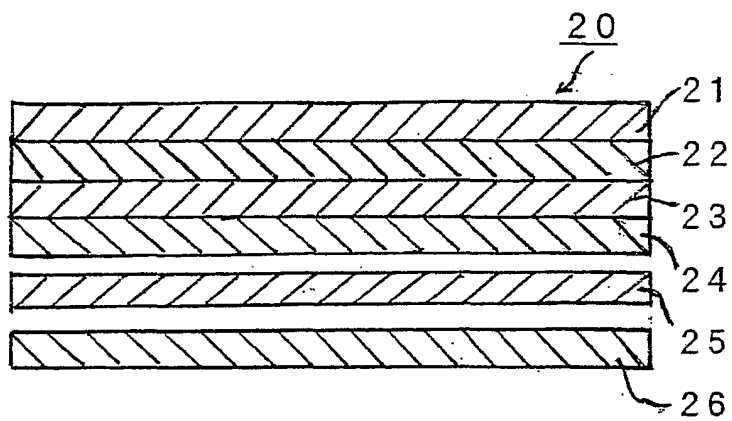

Fig. 5

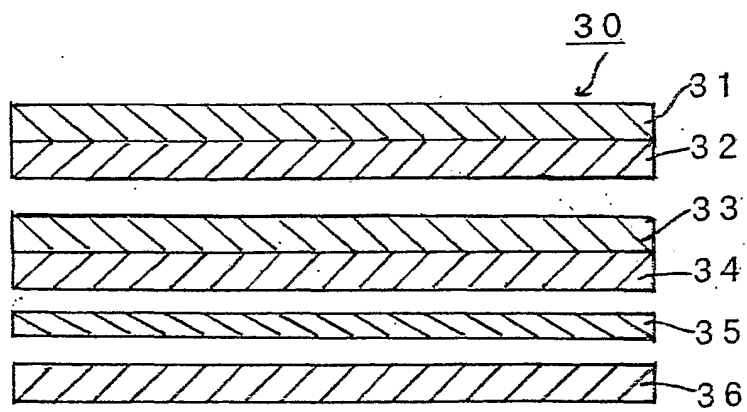
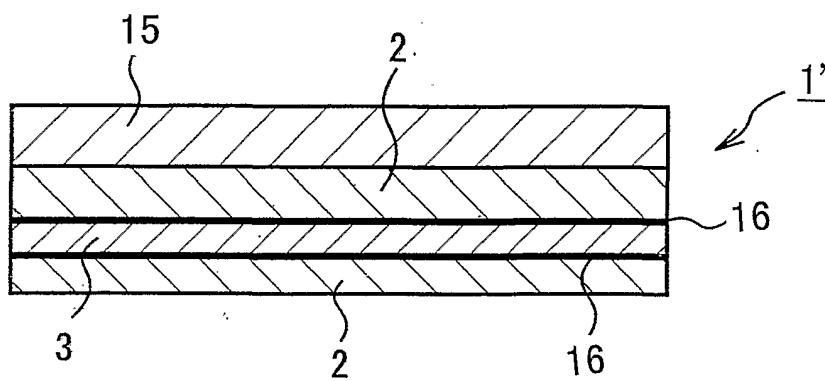

Fig. 6



INTERNATIONAL SEARCH REPORT

Int. Patent Application No  
PCT/JP 01/04832

A. CLASSIFICATION OF SUBJECT MATTER  
IPC 7 H01L31/048

According to International Patent Classification (IPC) or to both national classification and IPC

B. FIELDS SEARCHED

Minimum documentation searched (classification system followed by classification symbols)  
IPC 7 H01L

Documentation searched other than minimum documentation to the extent that such documents are included in the fields searched

Electronic data base consulted during the international search (name of data base and, where practical, search terms used)

WPI Data, EPO-Internal, PAJ

C. DOCUMENTS CONSIDERED TO BE RELEVANT

Category *	Citation of document, with indication, where appropriate, of the relevant passages	Relevant to claim No.
X	PATENT ABSTRACTS OF JAPAN vol. 2000, no. 07, 29 September 2000 (2000-09-29) & JP 2000 114565 A (DAINIPPON PRINTING CO LTD), 21 April 2000 (2000-04-21) abstract	1
X	PATENT ABSTRACTS OF JAPAN vol. 010, no. 046 (E-383), 22 February 1986 (1986-02-22) & JP 60 201652 A (TOPPAN INSATSU KK), 12 October 1985 (1985-10-12) abstract	1,2

Further documents are listed in the continuation of box C.

Patent family members are listed in annex.

\* Special categories of cited documents :

\*A\* document defining the general state of the art which is not considered to be of particular relevance

\*E\* earlier document but published on or after the international filing date

\*L\* document which may throw doubts on priority claim(s) or which is cited to establish the publication date of another citation or other special reason (as specified)

\*O\* document referring to an oral disclosure, use, exhibition or other means

\*P\* document published prior to the international filing date but later than the priority date claimed

\*T\* later document published after the international filing date or priority date and not in conflict with the application but cited to understand the principle or theory underlying the invention

\*X\* document of particular relevance; the claimed invention cannot be considered novel or cannot be considered to involve an inventive step when the document is taken alone

\*Y\* document of particular relevance; the claimed invention cannot be considered to involve an inventive step when the document is combined with one or more other such documents, such combination being obvious to a person skilled in the art.

\*&\* document member of the same patent family

Date of the actual completion of the international search

6 December 2001

Date of mailing of the international search report

13/12/2001

Name and mailing address of the ISA

European Patent Office, P.B. 5818 Patentlaan 2  
NL - 2280 HV Rijswijk  
Tel. (+31-70) 340-2040, Tx. 31 651 epo nl,  
Fax: (+31-70) 340-3016

Authorized officer

Visentin, A

## INTERNATIONAL SEARCH REPORT

 Inte Application No  
 PCT/JP 01/04832

## C.(Continuation) DOCUMENTS CONSIDERED TO BE RELEVANT

Category °	Citation of document, with indication, where appropriate, of the relevant passages	Relevant to claim No.
X	EP 0 631 328 A (CANON KK) 28 December 1994 (1994-12-28) page 9, line 15-23 page 9, line 54 -page 10, line 11 page 7, line 30-39; figure 12 ---	1,2,12, 13,15
A	EP 1 150 357 A (BRIDGESTONE CORP) 31 October 2001 (2001-10-31) the whole document & WO 00 35025 A (BRIDGESTONE CORPORATION) 15 June 2000 (2000-06-15) ---	1,2,12, 13,15
A	PATENT ABSTRACTS OF JAPAN vol. 1999, no. 02, 26 February 1999 (1999-02-26) & JP 10 308521 A (MITSUBISHI CHEM CORP), 17 November 1998 (1998-11-17) abstract ---	1,2,8,9, 14,15
A	PATENT ABSTRACTS OF JAPAN vol. 1995, no. 02, 31 March 1995 (1995-03-31) & JP 06 318728 A (CANON INC), 15 November 1994 (1994-11-15) abstract ---	1
P,X	WO 00 62348 A (IINO YASUHIRO ;OTANI KAORU (JP); TAKANO KAZUYA (JP); BRIDGESTONE C) 19 October 2000 (2000-10-19) figures 1-3 -----	1,2,10, 12,13,15

## INTERNATIONAL SEARCH REPORT

Information on patent family members

Int'l Application No

PCT/JP 01/04832

Patent document cited in search report		Publication date	Patent family member(s)	Publication date
JP 2000114565	A	21-04-2000	NONE	
JP 60201652 5	A		NONE	
EP 0631328	A	28-12-1994	DE 69410536 D1 DE 69410536 T2 EP 0631328 A1 JP 7142756 A US 5707459 A	02-07-1998 26-11-1998 28-12-1994 02-06-1995 13-01-1998
EP 1150357	A	31-10-2001	JP 2000174296 A JP 2000174297 A JP 2000174298 A JP 2000174299 A EP 1150357 A1 US 2001009160 A1 WO 0035025 A1	23-06-2000 23-06-2000 23-06-2000 23-06-2000 31-10-2001 26-07-2001 15-06-2000
JP 10308521 5	A		NONE	
JP 06318728 5	A	02-08-1988	NONE	
WO 0062348	A	19-10-2000	JP 2000294813 A WO 0062348 A1	20-10-2000 19-10-2000