

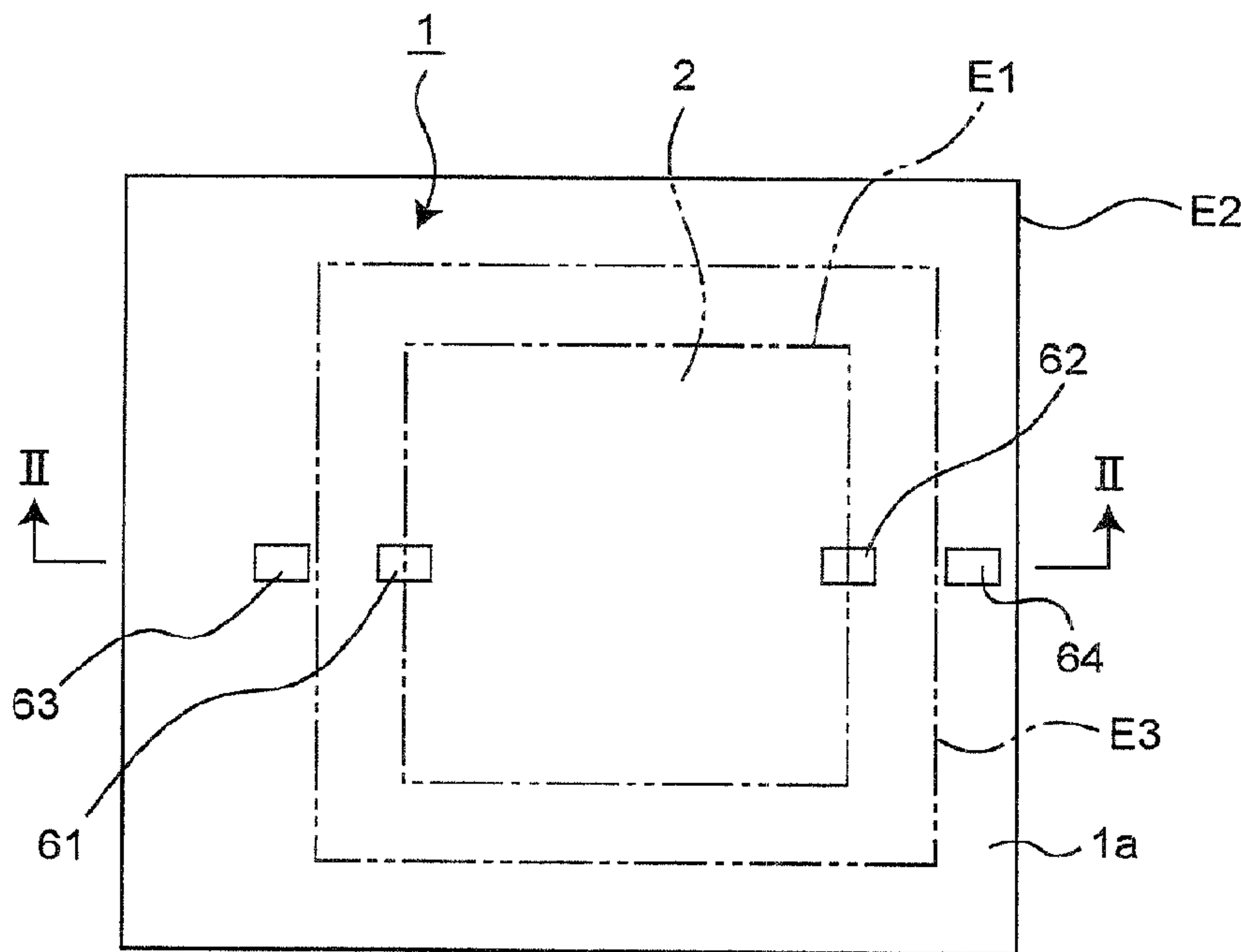

(22) Date de dépôt/Filing Date: 2003/05/29  
 (41) Mise à la disp. pub./Open to Public Insp.: 2004/01/19  
 (45) Date de délivrance/Issue Date: 2007/01/16  
 (30) Priorité/Priority: 2002/07/19 (JP2002-211654)

(51) Cl.Int./Int.Cl. *G01B 7/16* (2006.01),  
*B60J 7/057* (2006.01), *G01L 9/00* (2006.01),  
*G01P 15/12* (2006.01)  
 (72) Inventeurs/Inventors:  
 MIYAJIMA, HISAKAZU, JP;  
 ARAKAWA, MASAO, JP;  
 YABUTA, AKIRA, JP;  
 SAKAI JUN, JP  
 (73) Propriétaire/Owner:  
 MATSUSHITA ELECTRIC WORKS, LTD., JP  
 (74) Agent: KIRBY EADES GALE BAKER

(54) Titre : CAPTEUR POUVANT MESURER UNE GRANDEUR PHYSIQUE A L'AIDE D'UN COMPOSANT DE DEFORMATION MECANIQUE  
 (54) Title: MECHANICAL DEFORMATION AMOUNT SENSOR



(57) **Abrégé/Abstract:**

A mechanical deformation amount sensor includes a sensor structure which is formed by a semiconductor substrate or an insulating substrate. The sensor integrally includes a deformation portion deformable when a physical quantity to be detected is applied to the sensor structure. The sensor also includes a support portion for supporting the deformation portion, a carbon nanotube resistance element disposed on the deformation portion so as to be mechanically deformed in response to deformation of the deformation portion and a wiring pattern which is formed in a pattern on the sensor structure so as to be connected to the carbon nanotube resistance element. By applying a voltage to the carbon nanotube resistance element via the wiring pattern, a change of electrical conductivity of the carbon nanotube resistance element upon mechanical deformation of the carbon nanotube resistance element is transduced in an electrical signal.

**ABSTRACT**

A mechanical deformation amount sensor includes a sensor structure which is formed by a semiconductor substrate or an insulating substrate. The sensor integrally includes a deformation portion deformable when a physical quantity to be detected is applied to the sensor structure. The sensor also includes a support portion for supporting the deformation portion, a carbon nanotube resistance element disposed on the deformation portion so as to be mechanically deformed in response to deformation of the deformation portion and a wiring pattern which is formed in a pattern on the sensor structure so as to be connected to the carbon nanotube resistance element. By applying a voltage to the carbon nanotube resistance element via the wiring pattern, a change of electrical conductivity of the carbon nanotube resistance element upon mechanical deformation of the carbon nanotube resistance element is transduced in an electrical signal.

**MECHANICAL DEFORMATION AMOUNT SENSOR****FIELD OF INVENTION**

5

The present invention relates to mechanical deformation amount sensors such as acceleration sensors, pressure sensors or the like.

10 **BACKGROUND OF THE INVENTION**

As a sensor for detecting a magnitude of a physical quantity to be detected, a mechanical deformation amount sensor is known in which a mechanical deformation amount of a sensor structure caused by application of the physical quantity thereto is taken as an indicator of the magnitude of the physical quantity and is converted into an electrical signal. Typical examples include semiconductor acceleration sensors and semiconductor pressure sensors. In semiconductor acceleration sensors and semiconductor pressure sensors, the sensor structure is formed by a semiconductor substrate and a phenomenon in which when a stress is applied to a semiconductor crystal, electric resistance of the semiconductor crystal changes, namely, piezoelectric resistance, is utilized such that the stress generates an electrical signal.

Meanwhile, a strain sensor employing a carbon nanotube is proposed in, for example, Japanese Patent Laid-Open Publication No. 11-241903 (1999). This known strain sensor is a molded item having a sheet-like or any other predetermined shape in which electrically conductive fine particles of carbon nanotubes or the like are dispersed in a polymer formed by, for example, ethylene-



vinyl acetate copolymer (EVA). In this known strain sensor, a strain amount is detected by measuring a change of electric resistance, which is caused by stretching of the sensor due to an external force.

5

In the above described conventional sensor utilizing the piezoelectric resistance, when the sensor structure is formed on a silicon substrate, the piezoelectric resistance can be formulated by semiconductor diffusion technology in the course of the process of forming the sensor structure. Thus, the sensor structure can be advantageously manufactured by a series of semiconductor processes. However, since the rate of change of the piezoelectric resistance, i.e. electrical conductivity, corresponding to the amount of mechanical deformation of the sensor structure is limited, it is quite difficult to obtain sensitivities higher than that of the potential power of the piezoelectric resistance.

10  
15  
20

Meanwhile, in the above-mentioned strain sensor, since the molded item having the sheet-like or any other predetermined shape obtained by dispersing the electrically conductive fine particles of the carbon nanotube or the like in the polymer is used as a detecting resistance element, the combined resistance is increased by contact resistance of the particles, thereby resulting in a drop of sensitivity. Furthermore, in case the molded item having the sheet-like or any other predetermined shape is used as a mechanical deformation amount detection element, the molded item should be mounted on a structure in which a desired mechanical deformation amount can be detected. However, since it is difficult to mount the molded item on a mechanical deformation portion having a size of the order of several microns, a problem arises

25  
30

that the strain sensor as a whole becomes large.

#### **SUMMARY OF THE INVENTION**

5           Accordingly, an object of the present invention  
is to provide, with a view to eliminating the above-  
mentioned drawbacks of prior art, a mechanical deformation  
amount sensor such as an acceleration sensor, a pressure  
sensor or the like, which is capable of achieving higher  
10           sensitivity than prior art sensors.

          Certain exemplary embodiments can provide a  
mechanical deformation amount sensor, comprising: a sensor  
structure formed by one of a semiconductor substrate and an  
15           insulating substrate and integrally includes a deformation  
portion deformable, when a physical quantity to be detected  
is applied to the sensor structure, due to the physical  
quantity and a support portion for supporting the  
deformation portion; a first carbon nanotube resistance  
20           element provided on deformation portion to be mechanically  
deformed when the physical quantity to be detected is  
applied to said sensor structure; a second carbon nanotube  
resistance element provided on said support portion that is  
not deformed when the physical quantity to be detected is  
25           applied to said sensor structure; and a wiring pattern  
which is formed in a pattern on said sensor structure to be  
connected to said first carbon nanotube resistance element  
and said second carbon nanotube resistance element, wherein  
a voltage is applied to the first and second carbon  
30           nanotube resistance elements via said wiring pattern such  
that a change of electrical conductivity of said first  
carbon nanotube resistance element upon mechanical  
deformation of said first carbon nanotube resistance  
element is fetched as an electrical signal.



3a

Certain exemplary embodiments can provide a mechanical deformation amount sensor, comprising: a sensor structure formed by one of a semiconductor substrate or an insulating substrate and integrally including a deformation portion that is deformable, when a physical quantity to be detected is applied to said sensor structure, due to the physical quantity and a support portion for supporting said deformation portion; a carbon nanotube resistance element provided on said deformation portion to be mechanically deformed in response to a deformation of said deformation portion; and a wiring pattern formed in a pattern on said sensor structure to be connected to said carbon nanotube resistance element, wherein a voltage is applied to said carbon nanotube resistance element via said wiring pattern, such that a change of electrical conductivity of said carbon nanotube resistance element upon mechanical deformation of said carbon nanotube resistance element is fetched as an electrical signal, a reference resistance element being provided at a portion of said sensor structure other than said deformation portion, said reference resistance element and said carbon nanotube resistance element being connected to each other by said wiring pattern to form a bridge circuit.

25

Certain exemplary embodiments can provide a mechanical deformation amount sensor, comprising: a sensor structure formed by one of a semiconductor substrate or an insulating substrate and integrally including a deformation portion that is deformable, when a physical quantity to be detected is applied to said sensor structure, due to the physical quantity and a support portion for supporting said deformation portion; a carbon nanotube resistance element provided on said deformation

30

3b

portion to be mechanically deformed in response to a deformation of said deformation portion; and a wiring pattern formed in a pattern on said sensor structure to be connected to said carbon nanotube resistance element, 5 wherein a voltage is applied to said carbon nanotube resistance element via said wiring pattern, such that a change of electrical conductivity of said carbon nanotube resistance element upon mechanical deformation of said carbon nanotube resistance element is fetched as an 10 electrical signal, a step portion being formed on said deformation portion, said carbon nanotube resistance element being provided on said deformation portion so as to stride over said step portion.

15 Certain exemplary embodiments can provide a mechanical deformation amount sensor, comprising: a sensor structure formed by one of a semiconductor substrate or an insulating substrate and integrally including a deformation portion that is deformable, when a physical 20 quantity to be detected is applied to said sensor structure, due to the physical quantity and a support portion for supporting said deformation portion; a carbon nanotube resistance element provided on said deformation portion to be mechanically deformed in response to a deformation of said deformation portion; and a wiring 25 pattern formed in a pattern on said sensor structure to be connected to said carbon nanotube resistance element, wherein a voltage is applied to said carbon nanotube resistance element via said wiring pattern, such that a 30 change of electrical conductivity of said carbon nanotube resistance element upon mechanical deformation of said carbon nanotube resistance element is fetched as an electrical signal, said carbon nanotube resistance element being formed by a single-wall carbon nanotube, wherein



said carbon nanotube resistance element is formed by a plurality of single-wall carbon nanotubes which are arranged side by side and are electrically connected to each other in parallel.

5

Certain exemplary embodiments can provide a mechanical deformation amount sensor, comprising: a sensor structure formed by one of a semiconductor substrate or an insulating substrate and integrally including a deformation portion that is deformable, when a physical quantity to be detected is applied to said sensor structure, due to the physical quantity and a support portion for supporting said deformation portion; a carbon nanotube resistance element provided on said deformation portion to be mechanically deformed in response to a deformation of said deformation portion; and a wiring pattern formed in a pattern on said sensor structure to be connected to said carbon nanotube resistance element, wherein a voltage is applied to said carbon nanotube resistance element via said wiring pattern, such that a change of electrical conductivity of said carbon nanotube resistance element upon mechanical deformation of said carbon nanotube resistance element is fetched as an electrical signal, said mechanical deformation amount sensor acting as an acceleration sensor having an acceleration as the physical quantity to be detected, wherein said sensor structure further includes a weight portion integrally coupled with said support portion by said deformation portion.

10  
15  
20  
25



**BRIEF DESCRIPTION OF THE DRAWINGS**

This object and features of the present invention will become apparent from the following description taken in conjunction with the preferred embodiments thereof with reference to the accompanying drawings in which:

Fig. 1 is a top plan view of a pressure sensor according to a first embodiment of the present invention;

Fig. 2 is a sectional view taken along the line II-II in Fig. 1;

Fig. 3 is a circuit diagram of a bridge circuit for detecting a detection signal, employed in the pressure sensor of Fig. 1;

Fig. 4 is an explanatory view of the layout of electrodes and a metal wire in the bridge circuit of Fig. 3;

Fig. 5 is a sectional explanatory view of a carbon nanotube used for the bridge circuit of Fig. 3;

Fig. 6 is a sectional view explanatory of the carbon nanotube of Fig. 5;

Fig. 7 is a view similar to that of Fig. 2, particularly showing operation of the pressure sensor of Fig. 1;

Fig. 8 is a top plan view of a pressure sensor according to a second embodiment of the present invention;

Fig. 9 is a sectional view taken along the line IX-IX in Fig. 8;

5 Fig. 10 is a view similar to Fig. 9, particularly showing operation of the pressure sensor of Fig. 8;

10 Fig. 11 is a top plan view of a pressure sensor according to a third embodiment of the present invention;

Fig. 12 is a sectional view taken along the line XII-XII in Fig. 11;

15 Fig. 13 is a circuit diagram of a bridge circuit for detecting a detection signal, employed in the pressure sensor of Fig. 11;

20 Fig. 14 is a view similar to Fig. 12, particularly showing operation of the pressure sensor of Fig. 11;

25 Fig. 15 is a top plan view of an acceleration sensor according to a fourth embodiment of the present invention, the upper glass cap being removed therefrom;

Fig. 16 is a sectional view taken along the line XVI-XVI in Fig. 15, the upper glass cap being provided;

30

Fig. 17 is a view similar to Fig. 16; particularly showing operation of the acceleration sensor of Fig. 15;

Fig. 18 is a top plan view of an acceleration sensor according to a fifth embodiment of the present invention, the upper glass cap being removed therefrom;

5 Fig. 19 is a sectional view taken along the line XIX-XIX in Fig. 18, the upper glass cap being provided;

10 Fig. 20 is a view similar to Fig. 19, particularly showing operation of the acceleration sensor of Fig. 18;

15 Fig. 21 is a top plan view of an acceleration sensor according to a sixth embodiment of the present invention, the upper glass cap being removed therefrom; and

20 Fig. 22 is a sectional view taken along the line XXII-XXII in Fig. 21, the upper glass cap being provided.

25 Before the description of the present invention proceeds, it is to be noted that like parts are designated by like reference numerals throughout several views of the accompanying drawings.

#### DETAILED DESCRIPTION OF THE INVENTION

30 Hereinafter, mechanical deformation amount sensors according to embodiments of the present invention are described with reference to the drawings.

#### First embodiment



As shown in Figs. 1 and 2, a mechanical deformation amount sensor according to a first embodiment acts as a pressure sensor for detecting fluid pressure. In this embodiment, a sensor structure 1 is a so-called micro-electromechanical systems (MEMS) sensor chip (semiconductor pressure sensor chip) obtained from a silicon substrate. The pressure sensor chip 1 is constituted by a support portion 1a having the shape of a rectangular frame and a thin-walled diaphragm 2 occupying an inside space of the frame of the support portion 1a. In this pressure sensor chip 1, the diaphragm 2 acting as a thin-walled pressure bearing portion is formed by etching a recess 3 into a portion of a rear face of the pressure sensor chip 1 by anisotropic etching such that a wall of the recess 3, namely, the diaphragm 2 has a predetermined thickness. Thus, as shown in Fig. 1, the support portion 1a has three rectangular frame edges, i.e., an innermost rectangular frame edge E1 bounding the diaphragm 2, an outermost rectangular frame edge E2 defining an outer contour of the sensor structure 1 and an intermediate rectangular frame edge E3 defining a contour of a mouth of the recess 3. A base 4 made of glass and having a pressure introduction bore 5 for introducing the fluid pressure into the recess 3 is secured to the rear face of the pressure sensor chip 1. In the pressure sensor chip 1, when the fluid pressure is introduced from the pressure introduction bore 5 into the recess 3, the diaphragm 2 is deformed so as to be deflected.

30

In order to transduce an electrical signal from a deformation amount of the diaphragm 2 in accordance with magnitude of the fluid pressure, carbon nanotube resistance elements 61 and 62 are provided on a front face

of the diaphragm 2. Each of the carbon nanotube resistance elements 61 and 62 is provided and fixed at a central location of each of the opposite sides of the innermost rectangular frame edge E1 of the support portion 1a in a peripheral edge portion of the diaphragm 2 such that axes of the carbon nanotube resistance elements 61 and 62 are aligned with each other. A carbon nanotube has such a property that when the carbon nanotube is deformed in a direction perpendicular to an axial or longitudinal direction of the carbon nanotube, electrical conductivity (electric resistance) of the carbon nanotube changes in accordance with the deformation amount. Deflective deformation of the diaphragm 2 is produced in a thickness direction of the substrate. Hence, since the axial direction of the carbon nanotube is orthogonal to the direction of deflective deformation of the diaphragm 2 by the above described arrangement of the carbon nanotube resistance elements 61 and 62, deflective deformation of the diaphragm 2 is efficiently transmitted to the carbon nanotube resistance elements 61 and 62 and thus, the electrical conductivity of the carbon nanotube increases. Meanwhile, since the carbon nanotube resistance elements 61 and 62 are also provided in the peripheral edge portion of the diaphragm 2, whose deflective deformation is large, deflective deformation of the diaphragm 2 is efficiently transmitted to the carbon nanotube resistance elements 61 and 62, thereby resulting in increase of change of electrical conductivity of the carbon nanotube.

30 An overall length of the carbon nanotube resistance elements 61 and 62 may be placed on the diaphragm 2. However, in this embodiment, each of the carbon nanotube resistance elements 61 and 62 is disposed so as to stride over, at its longitudinal middle portion,



the boundary E1 of the diaphragm 2 and the support portion 1 a such that a substantially half portion of each of the carbon nanotube resistance elements 61 and 62 are placed on the diaphragm 2. This is because the diaphragm 2 is subjected to large deflective deformation in the neighborhood of the boundary E1 of the diaphragm 2 and the support portion 1a so as to flex.

Meanwhile, as shown in Fig. 3, a bridge circuit for detecting a detection signal is formed by the carbon nanotube resistance elements 61 and 62 and reference resistance elements 63 and 64. Each of the reference resistance elements 63 and 64 is provided and fixed on the front face of the support portion 1a which is not deformed by the fluid pressure. The axes of the reference resistance elements 63 and 64 are aligned with those of the carbon nanotube resistance elements 61 and 62. Carbon nanotubes are used as material of the reference resistance elements 63 and 64. The resistance elements 61 to 64 made of the carbon nanotubes are formed so as to have an identical electric resistance when no pressure is applied to the diaphragm 2. By using identical carbon nanotubes 61-64 having an identical resistance, the detection accuracy of the bridge circuit is improved.

25

In the bridge circuit, the carbon nanotube resistance elements 61 and 62 which are deformed in response to deformation of the diaphragm 2 are, respectively, disposed on a pair of opposite sides of the innermost rectangular frame edge E1 of the support portion 1a. The reference resistance elements 63 and 64 are respectively provided outside a pair of opposite sides of the intermediate rectangular frame edge E3 of the support portion 1a. A DC voltage  $V_d$  is applied between a junction

30



8a of the carbon nanotube resistance element 61 and the reference resistance element 64 and a junction 8b of the carbon nanotube resistance element 62 and the reference resistance element 63. A potential difference between a junction 9a of the carbon nanotube resistance element 61 and the reference resistance element 63 and a junction 9b of the carbon nanotube resistance element 62 and the reference resistance element 64 corresponds to the detection signal.

10

Fig. 4 shows an example of a wiring pattern 7 for connecting the resistance elements 61 to 64 so as to form the bridge circuit. In this example, the wiring pattern 7 is formed on the surface of the sensor structure 1 including the diaphragm 2, while electrode pads for the input terminals 8a and 8b for applying the DC voltage  $V_d$  to the bridge circuit and electrode pads for the output terminals 9a and 9b for providing the detection signal are disposed on the surface of the support portion 1a. The wiring pattern 7 can be formed by a metal wire such as aluminum but may also be formed through diffusion wiring by doping the silicon substrate acting as the pressure sensor chip 1. Alternatively, the wiring pattern may be formed by combination of the above two procedures.

25

Fig. 5 schematically shows the layout of a carbon nanotube 6 for forming the carbon nanotube resistance elements 61 and 62 and the reference resistance elements 63 and 64. As shown in Fig. 5, the carbon nanotube 6 is a rod-like minute structure connected, at its opposite end portions, to the wiring pattern 7. In order to form the carbon nanotube 6 at a predetermined location on the surface of the sensor structure 1, a method in which a carbon nanotube formed already into a

30

rod-like shape is provided and fixed at the predetermined location. Alternatively, a method in which a carbon nanotube is grown at the predetermined location on the surface of the sensor structure 1 may be employed. In the former method, a commercially available carbon nanotube can be used but the sensor structure 1 is minute and size of the carbon nanotube itself is quite small, so that handling of the carbon nanotube is not so easy. Hence, the latter method is preferably employed. In the latter method, a metal such as iron, nickel and cobalt or a compound containing one of said metals may be used as a catalyst and the carbon nanotube formed at the predetermined location by using the catalyst as a starting point. For example, in Fig. 5, at the location for providing the carbon nanotube 6 on the surface of the pressure sensor chip 1, ferric oxide ( $\text{Fe}_2\text{O}_3$ ) is formed as catalytic portions. The catalytic portions are disposed at locations corresponding to opposite end portions of the carbon nanotube 6 such that the carbon nanotube 6 is formed between the catalytic portions by such processes as chemical vapor deposition (CVD) and arc discharge. In order to form the catalytic portions, resist patterning, for example, is performed on the surface of the pressure sensor chip 1 so as to deposit, sputter, drip or spin coat the catalytic material. Meanwhile, in order to form the carbon nanotube 6, CVD or arc discharge is performed at a temperature ranging from 500 to  $1,000^\circ\text{C}$  while a mixed gas composed of hydrocarbon gas such as methane and hydrogen gas is provided for forming the carbon nanotube 6.

30

Carbon nanotubes are roughly classified into single-wall carbon nanotubes (SWNT) and multi-wall carbon nanotubes (MWNT). Single-wall carbon nanotubes are a cylindrical substance formed by a single graphite sheet.



On the other hand, multi-wall carbon nanotubes are a cylindrical substance formed by a plurality of graphite sheets provided concentrically or in a scroll. The carbon nanotube 6 employed in the present invention is preferably a single-wall carbon nanotube but may also be a multi-wall carbon nanotube. However, since change of electrical conductivity of single-wall carbon nanotubes upon its deformation in the direction orthogonal to the longitudinal direction is larger than that of multi-wall carbon nanotubes, single-wall carbon nanotubes are more advantageous for achieving high sensitivity than multi-wall carbon nanotubes. In this embodiment, each of the resistance elements 61 to 64 employing the carbon nanotubes 6 is formed by a plurality of single-wall carbon nanotubes which are arranged side by side and are electrically connected to each other in parallel. As a result, since scattering degrees of change of the electrical conductivity of the respective single-wall carbon nanotubes are averaged so as to be restrained, not only high sensitivity can be gained but detection accuracy can be improved.

In this embodiment, each of the opposite end portions of the carbon nanotube 6 is covered by a metal electrode 10 extending from the wiring pattern 7 and made of aluminum or titanium/gold. By providing the metal electrode 10, the opposite end portions of the carbon nanotube 6 and the wiring pattern 7 can be connected to each other positively. In addition, since the metal electrode 10 grips each of the opposite end portions of the carbon nanotube 6, the carbon nanotube 6 is firmly fixed so as to be prevented from being removed from the predetermined location on the surface of the chip 1.



In this embodiment, a surface of the carbon nanotube 6 may also be covered by an insulating coating film 13 as shown in Fig. 6. The insulating coating film 13 protects the carbon nanotube 6 and secures the carbon nanotube 6 to the pressure sensor chip 1 more firmly. The insulating coating film 13 may be provided so as to cover the carbon nanotube 6 spottily but a passivation film provided on the surface of the pressure sensor chip 1 may be used as the insulating coating film 13. Thus, the insulating coating film 13 not only protects the surface of the sensor chip 1 but protects and secures the carbon nanotube 6. As shown in Fig. 6, an insulating film 11 made of silicon dioxide ( $\text{SiO}_2$ ) or the like is provided on the surface of the pressure sensor chip 1 formed by the silicon substrate and the carbon nanotube 6 and the metal wire of the wiring pattern 7 are provided on the insulating film 11. In case the wiring pattern 7 includes a portion formed by diffusion wiring, the portion of diffusion wiring is disposed in the pressure sensor chip 1 under the insulating film 11 but may be electrically conducted to a surface of the insulating film 11 by forming a contact hole at a desired location of the insulating film 1.

In the semiconductor pressure sensor of the first embodiment, when no fluid pressure is introduced into the recess 3 from the pressure introduction bore 5 of the base 4, the potential difference between the output terminals 9a and 9b of the bridge circuit is zero. However, if fluid pressure is introduced into the recess 3 from the pressure introduction bore 5 of the base 4, a central portion of the diaphragm 2 is deflected by the fluid pressure so as to be expanded upwardly as shown in Fig. 7 and the peripheral edge portion of the diaphragm 2

is deformed so as to be pulled obliquely upwardly. Thus, the carbon nanotube resistance elements 61 and 62 fixed at the peripheral edge portion of the diaphragm 2 are subjected to compressive deformation in a direction orthogonal to their axial direction, i.e. in a direction of small modulus of elasticity in response to deformation of the peripheral edge portion of the diaphragm 2. By this compressive deformation of the carbon nanotube resistance elements 61 and 62, electric resistance, i.e., electrical conductivity between the carbon nanotube resistance elements 61 and 62 changes in accordance with amount of the compressive deformation and a potential difference corresponding to the change of the electric resistance is generated between the output terminals 9a and 9b of the bridge circuit. Since a magnitude of this potential difference corresponds to a magnitude of the fluid pressure applied to the diaphragm 2, the fluid pressure can be detected from this potential difference.

## 20 Second embodiment

Figs. 8 and 9 show a semiconductor pressure sensor according to a second embodiment of the present invention. In the first embodiment, a surface of the pressure sensor chip 1 including the diaphragm 2 is flat and the carbon nanotube resistance elements 61 and 62 are arranged and fixed on this flat surface of the pressure sensor chip 1. The second embodiment is designed to make the best use of such a property of a carbon nanotube that electric resistance of the carbon nanotube changes greatly at its location having a large angle of deformation.

Namely, in this embodiment, a step portion 12 is formed at a boundary of the peripheral edge portion,



i.e., a deformation portion of the diaphragm 2 and the support portion 1 a as shown in Fig. 9 such that a surface of the diaphragm 2 is set lower than that of the support portion 1 a surrounding the diaphragm 2. Each of the carbon nanotube resistance elements 61 and 62 is disposed and fixed so as to longitudinally stride over the step portion 12 and is bent from the surface of the support portion 1a to the surface of the diaphragm 2 along a vertical surface of the step portion 12. Since other constructions of the semiconductor pressure sensor of this embodiment are similar to those of the pressure sensor of the first embodiment, the description is abbreviated for the sake of brevity.

15 In the semiconductor pressure sensor, when fluid pressure is introduced into the recess 3 from the pressure introduction bore 5 of the base 4, a central portion of the diaphragm 2 is deflected by the fluid pressure so as to be expanded upwardly and the peripheral edge portion of the diaphragm 2 is deformed so as to be pulled obliquely upwardly as shown in Fig. 10. Thus, each of the carbon nanotube resistance elements 61 and 62 secured to the step portion 12 in the peripheral edge portion of the diaphragm 2 is subjected to compressive deformation in a direction orthogonal to its axial or longitudinal direction, i.e., in a direction of small modulus of elasticity in response to deformation of the peripheral edge portion of the diaphragm 2. At this time, since a portion of each of the carbon nanotube resistance elements 61 and 62, which is disposed at the step portion 12, is subjected to compressive deformation at a large angle, the electric resistance (electrical conductivity) between opposite ends of each of the carbon nanotube resistance elements 61 and 62 changes greatly and thus,



the potential difference between the output terminals 9a and 9b of the bridge circuit becomes large. Namely, since a large-level electrical signal can be obtained by the small deformation amount, the fluid pressure can be  
5 detected at high sensitivity.

### Third embodiment

10 Figs. 11 and 12 show a semiconductor pressure sensor according to a third embodiment of the present invention. In the first and second embodiments, the bridge circuit is formed by providing the reference resistance elements 63 and 64. In this embodiment, reference  
15 resistance elements 63' and 64' are provided at a central portion of a surface of the diaphragm 2 such that an axial direction of the reference resistance elements 63' and 64' is parallel to that of the carbon nanotube resistance elements 61 and 62 disposed in the peripheral edge portion  
20 of the diaphragm 2. A bridge circuit shown in Fig. 13 is formed by using the reference resistance elements 63' and 64'. The reference resistance elements 63' and 64' are constituted by carbon nanotubes.

25 In the semiconductor pressure sensor, when fluid pressure is introduced into the recess 3 from the pressure introduction bore 5 of the base 4, a central portion of the diaphragm 2 is deflected by the fluid pressure so as to be expanded upwardly and the peripheral  
30 edge portion of the diaphragm 2 is deformed so as to be pulled obliquely upwardly as shown in Fig. 14. Thus the reference resistance elements 63' and 64' disposed at the central portion of the diaphragm 2 are deformed so as to be stretched, while the carbon nanotube resistance

elements 61 and 62 fixed at the peripheral edge portion of the diaphragm 2 are subjected to compressive deformation in a direction orthogonal to an axial direction of the carbon nanotube resistance elements 61 and 62, i.e., in a direction of small modulus of elasticity in response to deformation of the peripheral edge portion of the diaphragm 2. A direction of change of electric resistance of the carbon nanotube resistance elements 61 and 62 is opposite to that of the reference resistance elements 63' and 64'.

Thus, potential difference produced between the output terminals 9a and 9b of the bridge circuit becomes larger than that of the first embodiment. Namely, since a large-level electrical signal can be obtained by the small deformation amount, the fluid pressure can be detected at higher sensitivity.

#### 20 Fourth embodiment

Figs. 15 and 16 show an acceleration sensor according to a fourth embodiment of the present invention. In the first to third embodiments, the mechanical deformation amount sensor acted as a pressure sensor. In this fourth embodiment, the mechanical deformation amount sensor acts as the acceleration sensor. By performing micromachining such as etching on a silicon substrate as shown in Fig. 15, an acceleration sensor chip 20 is formed. This acceleration sensor chip 20 includes a frame-like support portion 21 and a weight portion 22 whose one side is integrally attached to the support portion 21 by a pair of parallel beam portions 23. The weight portion 22 is pivotally provided in a space surrounded by the support



portion 21. As shown in Fig. 16, a metallic film 24 is provided on an upper surface of the support portion 21 along an outer peripheral portion of the acceleration sensor chip 20. An upper glass cap 26 formed with a recess 5 25 enabling upward movement of the weight portion 22, is provided on an upside of the acceleration sensor chip 20. The underside of this upper glass cap 26 is bonded to the outer peripheral portion of the upside of the acceleration sensor chip 20 via the metallic film 24.

10

A lower glass cap 28 formed with a recess 27 enabling downward movement of the weight portion 22 is secured to an underside of the acceleration sensor chip 20. An outer peripheral portion of an upside of the lower 15 glass cap 28 is bonded to the underside of the support portion 21 of the acceleration sensor chip 20 by anodic bonding.

The carbon nanotube resistance elements 61 and 20 62 are fixed to the beam portions 23 acting as a deformation portion which is deformed by pivotal movement of the weight portion 22. The carbon nanotube resistance elements 61 and 62 are disposed so as to axially or longitudinally stride over the beam portions 23 and the 25 weight portion 22 such that an axial direction of the carbon nanotube resistance elements 61 and 62 is orthogonal to a direction of deformation of the beam portions 23. Meanwhile, the reference resistance elements 63 and 64 formed by carbon nanotubes are secured to an 30 upside of the weight portion 22 so as to axially extend orthogonally to the axial direction of the carbon nanotube resistance elements 61 and 62. The resistance elements 61 to 64 are fixed to the acceleration sensor chip 20 in the same manner as the first embodiment. Although a metal



wire for effecting bridge connection of the resistance elements 61 to 64 in the same manner as depicted in Fig. 3 is formed on the surface of the support portion 21, the weight portion 22 and the beam portions 23 and input and output electrodes of the bridge circuit are formed on the surface of the support portion 21, these circuit components are not shown in Figs. 15 and 16. In Fig. 16, stoppers 29 and 30 for restraining movement of the weight portion 22 are, respectively, provided on the upper glass cap 26 and the lower glass cap 28.

If an acceleration is applied to the acceleration sensor in the direction of the arrow Y as shown in Fig. 17, a force corresponding to the acceleration is applied to the weight portion 22 so as to pivot the weight portion 22 as shown. By this pivotal movement of the weight portion 22, the beam portions 23 for coupling the support portion 21 and the weight portion 22 with each other are subjected to deflective deformation and thus, the carbon nanotube resistance elements 61 and 62 are also deformed in response to this deflective deformation of the beam portions 23.

A deformation amount of the carbon nanotube resistance elements 61 and 62 corresponds to a magnitude of the acceleration and the electric resistance (electrical conductivity) between opposite ends of the carbon nanotube resistance elements 61 and 62 changes in response to this deformation amount. Thus, potential difference corresponding to the change of electric resistance is produced between the output terminals 9a and 9b of the bridge circuit as shown in Fig. 3. Since the magnitude of this potential difference corresponds to the

magnitude of the acceleration applied to the weight portion 22, the acceleration can be detected from the potential difference.

5

#### Fifth embodiment

Figs. 18 and 19 show an acceleration sensor according to a fifth embodiment of the present invention. In this embodiment, a step portion 23a is formed on an upside of the beam portion 23 by setting a surface of the support portion 21 higher than that of the weight portion 22 as shown in Figs. 18 and 19. Each of the carbon nanotube resistance elements 61 and 62 is disposed and fixed so as to stride over the step portion 23a from the surface of the support portion 21 to the surface of the weight portion 22.

Namely, in the same manner as the step portion 12 of the second embodiment, a large change of electric resistance of the carbon nanotube resistance elements 61 and 62 is obtained upon deformation of the beam portions 23 in order to increase sensor sensitivity. Since a function of the step portion 23a is identical with that of the step portion 12 of the second embodiment, the description is not repeated for sake of brevity. Also, since operation of the acceleration sensor at the time an acceleration is applied thereto in the direction of the arrow Y as shown in Fig. 20 is similar to that of the fourth embodiment, the description is not repeated for sake of brevity.

#### Sixth embodiment



Figs. 21 and 22 show an acceleration sensor according to a sixth embodiment of the present invention. In the acceleration sensors of the fourth and fifth embodiments, the reference resistance elements 63 and 64 formed by the carbon nanotubes are provided on the upside of the weight portion 22. In this embodiment, the reference resistance elements 63' and 64' are fixed to the beam portions 23 as shown in Figs. 21 and 22 such that axes of the reference resistance elements 63' and 64' are orthogonal to those of the carbon nanotube resistance elements 61 and 62. The bridge circuit shown in Fig. 13 is constituted by the resistance elements 61, 62, 63' and 64' formed by carbon nanotubes. Since other constructions of the acceleration sensor are similar to those of the fourth embodiment, the description is not repeated for sake of brevity.

The embodiments have been described above as concrete examples of the present invention. However, it is needless to say that the present invention is not limited to these embodiments but may be modified variously. For example, in case the reference resistance elements are used in the above embodiments, the reference resistance elements may be replaced by diffused resistors. Meanwhile, in the above embodiments, the MEMS sensor employing the silicon substrate is recited as an example but may be replaced by a sensor structure formed by a substrate made of another semiconductor material. In the present invention, since the carbon nanotubes are used as the detection elements, there is no restriction that a semiconductor substrate should be used as the substrate as in a configuration based on piezoelectric resistance. A substrate made of an insulating material such as glass can also be used.



Furthermore, the above embodiments were directed to pressure sensors and acceleration sensors. However, other sensors such as, for example, tactile sensors for detecting contact pressure, sound wave sensors (microphone) for detecting air pressure, ultrasonic sensors, sensors for detecting pressure changes in a human body may also be developed using mechanical deformation amount sensor technology.

By the above described arrangement of the mechanical deformation amount sensor of the present invention, the physical quantity can be detected based on electrical characteristics of the carbon nanotube at higher sensitivity than in prior art sensors. Namely, when the physical quantity to be detected by the sensor is applied to the sensor structure in a state where the voltage is applied to the carbon nanotube resistance element via the wiring pattern, the deformation portion is initially deformed and then, the carbon nanotube resistance element is mechanically deformed in response to the deformation of the deformation portion. The carbon nanotube has a property that its electrical conductivity (electric resistance) changes upon its mechanical deformation. Since quantity of change of its electrical conductivity is quite large in comparison with piezoelectric resistance, the electrical conductivity of the carbon nanotube resistance element changes rather greatly upon its mechanical deformation, so that quantity of change of voltage or electric current due to the change of the electrical conductivity becomes comparatively large and is converted, through the wiring pattern, into a highly sensitive electrical signal. Since this electrical signal is used as an index indicative of magnitude of the physical quantity to be detected and is converted into the

physical quantity, the physical quantity can be detected at high sensitivity.

In the present invention, if the deformation  
5 portion is subjected to mechanical deformation when the physical quantity to be detected is applied to the sensor structure, the deformation portion is not specifically restricted in shape, etc. For example, the deformation portion can be so formed as to be thinner than the support  
10 portion and is deformed so as to be deflected elastically when the physical quantity is applied to the sensor structure.

Meanwhile, in the present invention, the sensor  
15 structure is preferably a so-called micro-electro-mechanical systems (MEMS) sensor chip formed by micromachining a silicon substrate. In the present invention employing the carbon nanotube which is a quite minute element, the MEMS sensor chip is very advantageous  
20 for achieving both high sensitivity and compactness. In this case, the carbon nanotube resistance element is preferably provided on the deformation portion through an insulating film.

25 Furthermore, in the present invention, the carbon nanotube resistance element is preferably disposed such that a longitudinal direction of the carbon nanotube resistance element is orthogonal to a direction of deformation of the deformation portion. The carbon  
30 nanotube has a property that its electrical conductivity changes upon its deformation in a direction orthogonal to its longitudinal direction. Since the longitudinal direction of the carbon nanotube resistance element is orthogonal to the direction of deformation of the



deformation portion, deformation of the deformation portion is reflected most precisely in deformation of the carbon nanotube resistance element. As a result, change of electrical conductivity of the carbon nanotube resistance element increases accordingly, which is advantageous for achieving high sensitivity.

Additionally, in the present invention, the wiring pattern may have, at its end portion connected to the carbon nanotube resistance element, a metal electrode such that each of opposite end portions of the carbon nanotube resistance element is covered by the metal electrode. Thus, the carbon nanotube resistance element can be positively connected to the wiring pattern by the metal pattern and the carbon nanotube resistance element can be securely fixed to the deformation portion.

Meanwhile, in the present invention, a surface of the carbon nanotube resistance element is preferably covered by an insulating coating film. This is because the insulating coating film can not only protect the carbon nanotube resistance element but fix the carbon nanotube resistance element to the deformation portion more securely. In this case, the insulating coating film may be formed by a passivation film provided on a surface of the sensor structure so as to not only protect the surface of the sensor structure but protect and fix the carbon nanotube resistance element.

Also, in the present invention, it is preferable that a step portion be formed on the deformation portion and the carbon nanotube resistance element be provided on the deformation portion so as to stride over the step portion.



Thus, the change of the electrical conductivity of the carbon nanotube at its portion having a large angle of deformation is large as compared with a case in which  
5 the carbon nanotube resistance element is provided on a flat face. A large change of electrical conductivity can be obtained in response to a small deformation amount and thus, higher sensitivity can be achieved.

10 Meanwhile, in the present invention, it is preferable that a reference resistance element be provided at a portion of the sensor structure other than the deformation portion and that the reference resistance  
15 element and the carbon nanotube resistance element be connected to each other by the wiring pattern so as to form a bridge circuit. In this case, a voltage is applied to an input terminal of the bridge circuit and a voltage of an output terminal of the bridge circuit can be  
20 detected as an electrical signal corresponding to a change of electrical conductivity of the carbon nanotube resistance element upon mechanical deformation of the carbon nanotube resistance element. High sensitivities can be gained and detection accuracy improved. In this  
25 case, the reference resistance element is preferably formed by a carbon nanotube. When both the detective resistance element and the reference resistance element are identically formed by the carbon nanotubes, detection accuracy is improved further.

30 Meanwhile, in the present invention, the carbon nanotube resistance element is preferably formed by a single-wall carbon nanotube. This is because change of electrical conductivity of the single-wall carbon nanotube upon its deformation in a direction orthogonal to its

longitudinal direction is larger than that of a multi-wall carbon nanotube. In this case, it is preferable that the carbon nanotube resistance element be formed by a plurality of the single-wall carbon nanotubes which are  
5 arranged side by side and are electrically connected to each other in parallel. Thus, since scattering degrees of change of electrical conductivity of the respective single-wall carbon nanotubes are averaged so as to be restrained, not only high sensitivity can be gained but  
10 detection accuracy can be improved.

Furthermore, in the present invention, an acceleration sensor having an acceleration as the physical quantity to be detected is provided as one concrete  
15 example of the mechanical deformation amount sensor. In the acceleration sensor, the sensor structure further includes a weight portion integrally coupled with the support portion by the deformation portion.

Moreover, in the present invention, a pressure sensor having a fluid pressure as the physical quantity to be detected is provided as another concrete example of the  
20 mechanical deformation amount sensor. In the sensor structure of the pressure sensor, the support portion is formed in a shape of a frame and the deformation portion is formed by a diaphragm occupying an inside space of the frame of the support portion such that the diaphragm bears  
25 the fluid pressure. In this case, the carbon nanotube resistance element is preferably provided at a peripheral edge portion of the diaphragm.  
30

As is clear from the foregoing description, mechanical deformation amount sensors of the present invention can detect, as an electrical signal based on



change of electrical conductivity of carbon nanotube resistance elements, magnitude of a physical quantity applied to the sensor structure. Such a remarkable effect is gained by utilizing electrical characteristics of the carbon nanotube. The physical quantity can be detected at higher sensitivity than prior art configurations employing, for example, a piezoelectric resistance element.

## CLAIMS:

1. A mechanical deformation amount sensor,  
comprising:

5

a sensor structure formed by one of a  
semiconductor substrate and an insulating substrate and  
integrally includes a deformation portion deformable, when  
a physical quantity to be detected is applied to the  
10 sensor structure, due to the physical quantity and a  
support portion for supporting the deformation portion;

a first carbon nanotube resistance element  
provided on deformation portion to be mechanically  
15 deformed when the physical quantity to be detected is  
applied to said sensor structure;

a second carbon nanotube resistance element  
provided on said support portion that is not deformed when  
20 the physical quantity to be detected is applied to said  
sensor structure; and

a wiring pattern which is formed in a pattern  
on said sensor structure to be connected to said first  
25 carbon nanotube resistance element and said second carbon  
nanotube resistance element,

wherein a voltage is applied to the first and  
second carbon nanotube resistance elements via said wiring  
30 pattern such that a change of electrical conductivity of  
said first carbon nanotube resistance element upon  
mechanical deformation of said first carbon nanotube  
resistance element is fetched as an electrical signal.



2. The mechanical deformation amount sensor of claim 1, wherein said deformation portion is formed to be thinner than said support portion and is deformed to be deflected elastically when the physical quantity is applied to said sensor structure.

3. The mechanical deformation amount sensor of claim 1, wherein said sensor structure comprises a micro-electro-mechanical systems (MEMS) sensor chip formed by a silicon substrate.

4. The mechanical deformation amount sensor of claim 3, wherein said first carbon nanotube resistance element is provided on said deformation portion through an insulating film.

5. The mechanical deformation amount sensor of claim 1, wherein said first carbon nanotube resistance element is disposed such that a longitudinal direction of said first carbon nanotube resistance element is orthogonal to a direction of deformation of said deformation portion.

6. The mechanical deformation amount sensor of claim 1, wherein said wiring pattern has, at an end portion connected to said first carbon nanotube resistance element, a metal electrode such that each of opposite end portions of said first carbon nanotube resistance element is covered by said metal electrode.

30

7. The mechanical deformation amount sensor of claim 1, wherein a surface of said first carbon nanotube resistance element is covered by an insulating coating film.

8. The mechanical deformation amount sensor of claim 7, wherein said insulating coating film comprises a passivation film provided on a surface of said sensor structure.

5

9. The mechanical deformation amount sensor of claim 1, wherein the carbon nanotube resistance element is formed by a single-wall carbon nanotube.

10 10. The mechanical deformation amount sensor of claim 1, which acts as a pressure sensor having a fluid pressure as the physical quantity to be detected,

15 wherein in said sensor structure, said support portion is formed in a shape of a frame and said deformation portion is formed by a diaphragm occupying an inside space of said frame of said support portion such that said diaphragm bears the fluid pressure.

20 11. The mechanical deformation amount sensor of claim 10, wherein said carbon nanotube resistance element is provided at a peripheral edge portion of said diaphragm.

25 12. A mechanical deformation amount sensor, comprising:

30 a sensor structure formed by one of a semiconductor substrate or an insulating substrate and integrally including a deformation portion that is deformable, when a physical quantity to be detected is applied to said sensor structure, due to the physical quantity and a support portion for supporting said deformation portion;



a carbon nanotube resistance element provided on said deformation portion to be mechanically deformed in response to a deformation of said deformation portion; and

5 a wiring pattern formed in a pattern on said sensor structure to be connected to said carbon nanotube resistance element, wherein a voltage is applied to said carbon nanotube resistance element via said wiring pattern, such that a change of electrical conductivity of  
10 said carbon nanotube resistance element upon mechanical deformation of said carbon nanotube resistance element is fetched as an electrical signal, a reference resistance element being provided at a portion of said sensor structure other than said deformation portion, said  
15 reference resistance element and said carbon nanotube resistance element being connected to each other by said wiring pattern to form a bridge circuit.

13. The mechanical deformation amount sensor of  
20 claim 12, wherein said reference resistance element comprises a carbon nanotube.

14. A mechanical deformation amount sensor,  
comprising:

25 a sensor structure formed by one of a semiconductor substrate or an insulating substrate and integrally including a deformation portion that is deformable, when a physical quantity to be detected is  
30 applied to said sensor structure, due to the physical quantity and a support portion for supporting said deformation portion;

a carbon nanotube resistance element provided on said deformation portion to be mechanically deformed in response to a deformation of said deformation portion; and

5 a wiring pattern formed in a pattern on said sensor structure to be connected to said carbon nanotube resistance element, wherein a voltage is applied to said carbon nanotube resistance element via said wiring pattern, such that a change of electrical conductivity of  
10 said carbon nanotube resistance element upon mechanical deformation of said carbon nanotube resistance element is fetched as an electrical signal, a step portion being formed on said deformation portion, said carbon nanotube resistance element being provided on said deformation  
15 portion so as to stride over said step portion.

15. A mechanical deformation amount sensor, comprising:

20 a sensor structure formed by one of a semiconductor substrate or an insulating substrate and integrally including a deformation portion that is deformable, when a physical quantity to be detected is applied to said sensor structure, due to the physical  
25 quantity and a support portion for supporting said deformation portion;

a carbon nanotube resistance element provided on said deformation portion to be mechanically deformed in  
30 response to a deformation of said deformation portion; and

a wiring pattern formed in a pattern on said sensor structure to be connected to said carbon nanotube resistance element, wherein a voltage is applied to said



carbon nanotube resistance element via said wiring pattern, such that a change of electrical conductivity of said carbon nanotube resistance element upon mechanical deformation of said carbon nanotube resistance element is  
5 fetched as an electrical signal, said carbon nanotube resistance element being formed by a single-wall carbon nanotube, wherein said carbon nanotube resistance element is formed by a plurality of single-wall carbon nanotubes which are arranged side by side and are electrically  
10 connected to each other in parallel.

16. A mechanical deformation amount sensor, comprising:

15 a sensor structure formed by one of a semiconductor substrate or an insulating substrate and integrally including a deformation portion that is deformable, when a physical quantity to be detected is applied to said sensor structure, due to the physical  
20 quantity and a support portion for supporting said deformation portion;

a carbon nanotube resistance element provided on said deformation portion to be mechanically deformed in  
25 response to a deformation of said deformation portion; and

a wiring pattern formed in a pattern on said sensor structure to be connected to said carbon nanotube resistance element, wherein a voltage is applied to said  
30 carbon nanotube resistance element via said wiring pattern, such that a change of electrical conductivity of said carbon nanotube resistance element upon mechanical deformation of said carbon nanotube resistance element is fetched as an electrical signal, said mechanical

deformation amount sensor acting as an acceleration sensor having an acceleration as the physical quantity to be detected,

- 5                    wherein said sensor structure further includes a weight portion integrally coupled with said support portion by said deformation portion.

Fig. 1

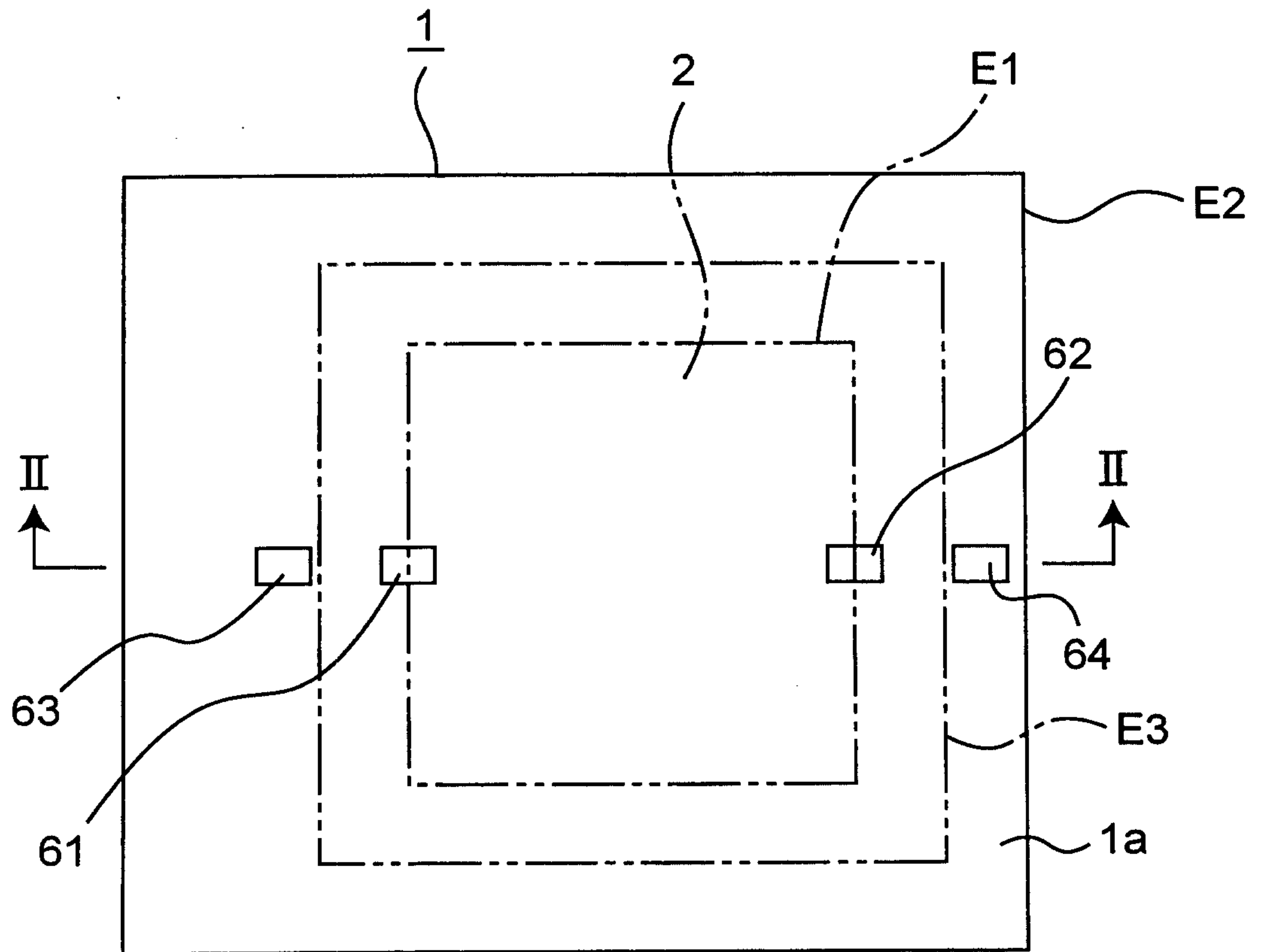

Fig. 2

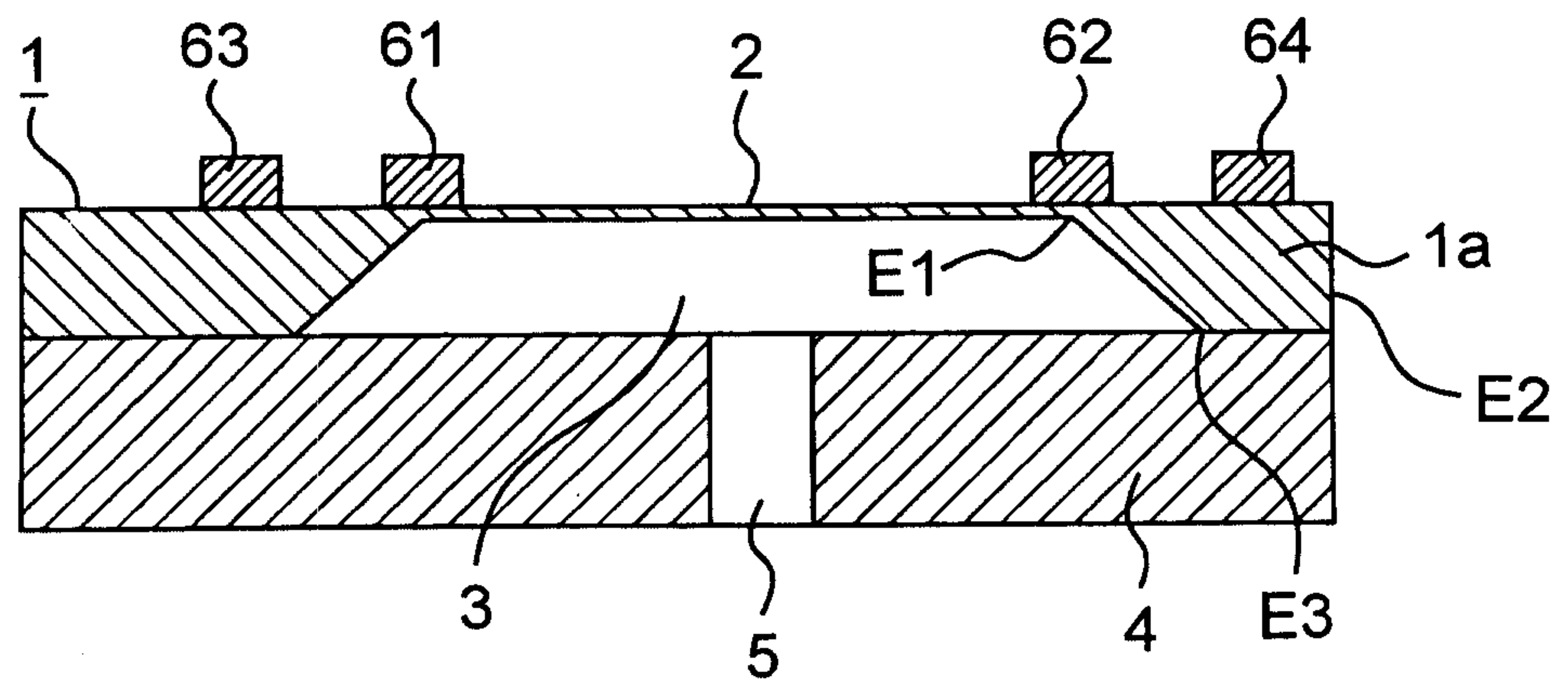
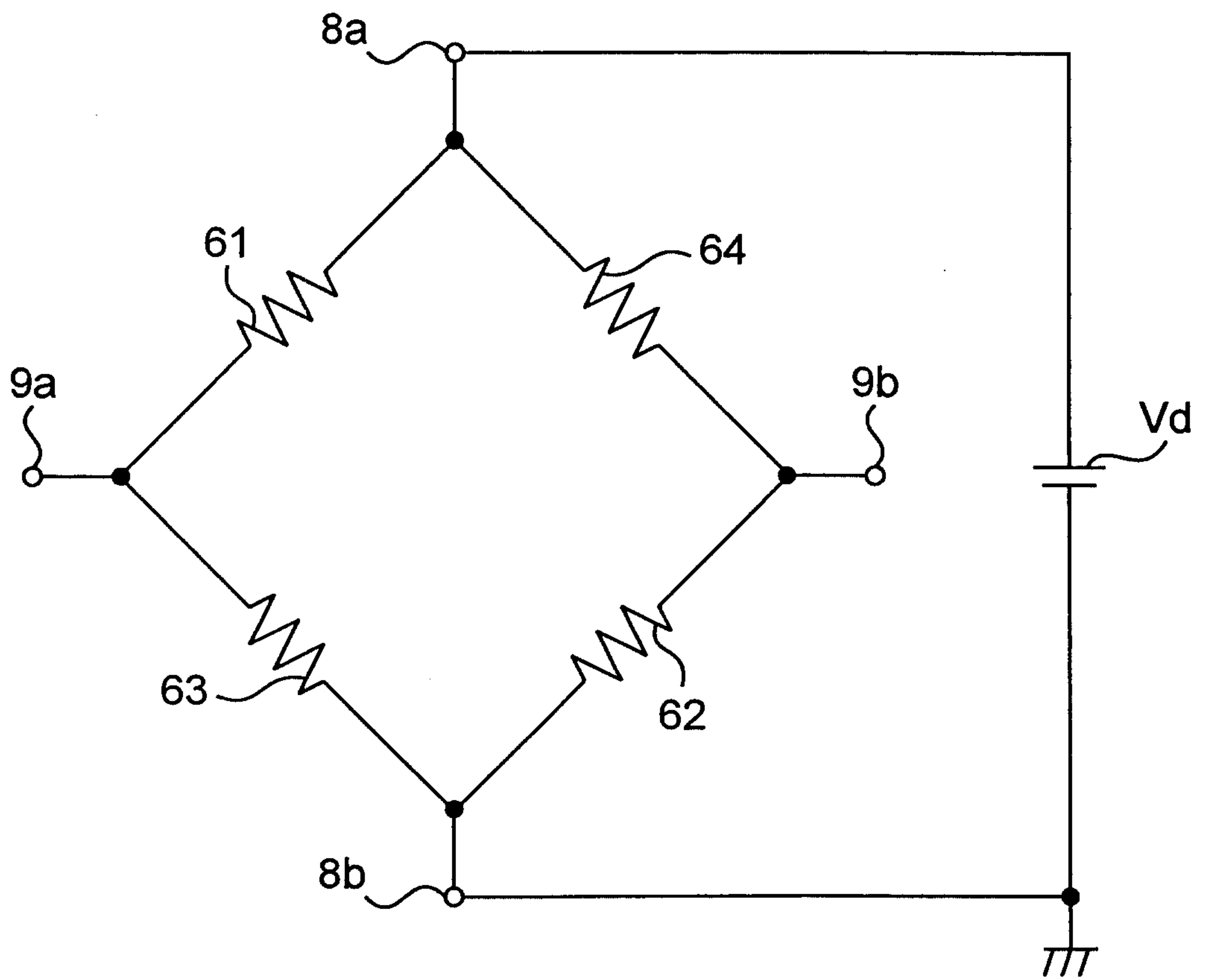
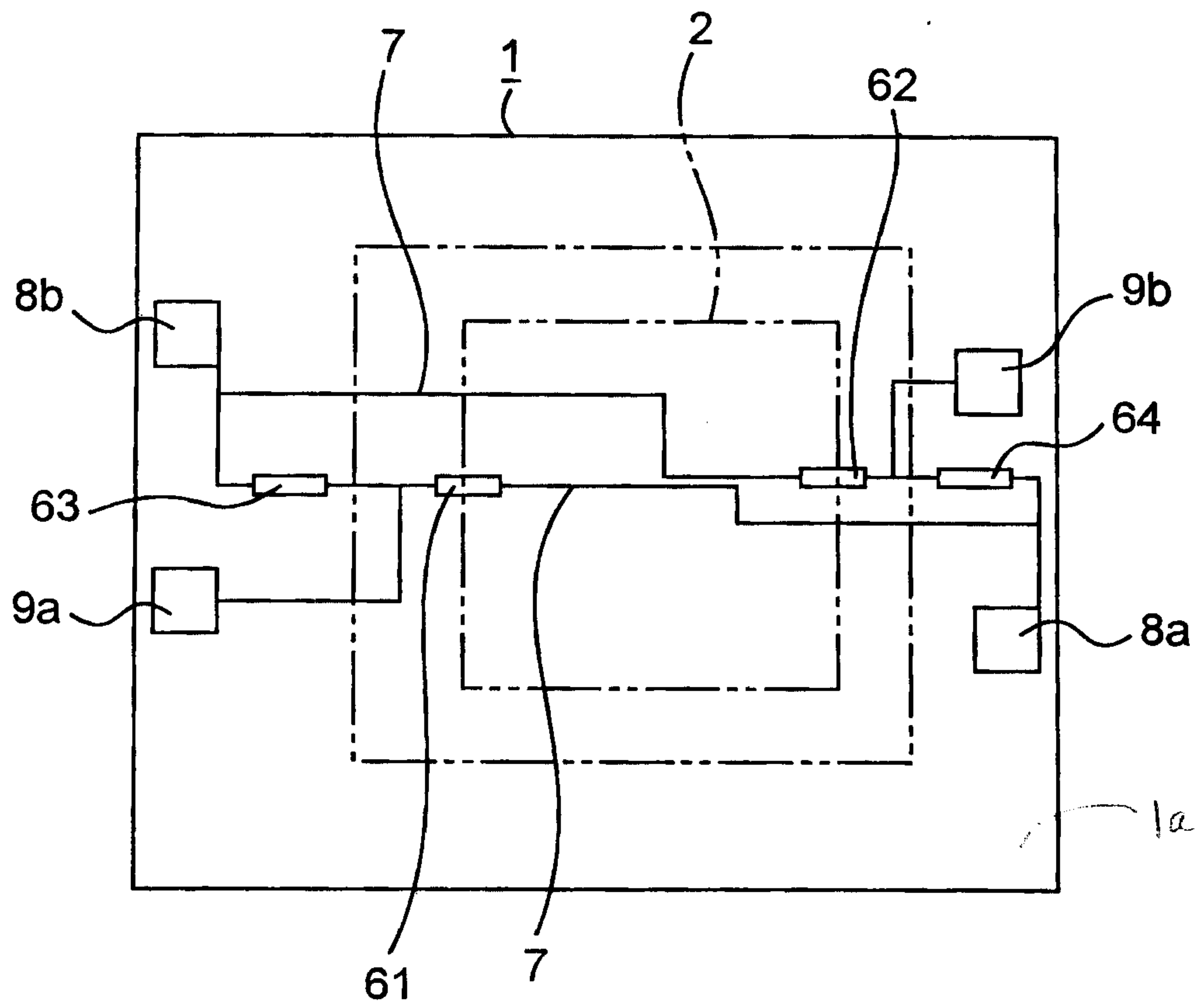



Fig.3



**Fig.4**



**Fig.5**

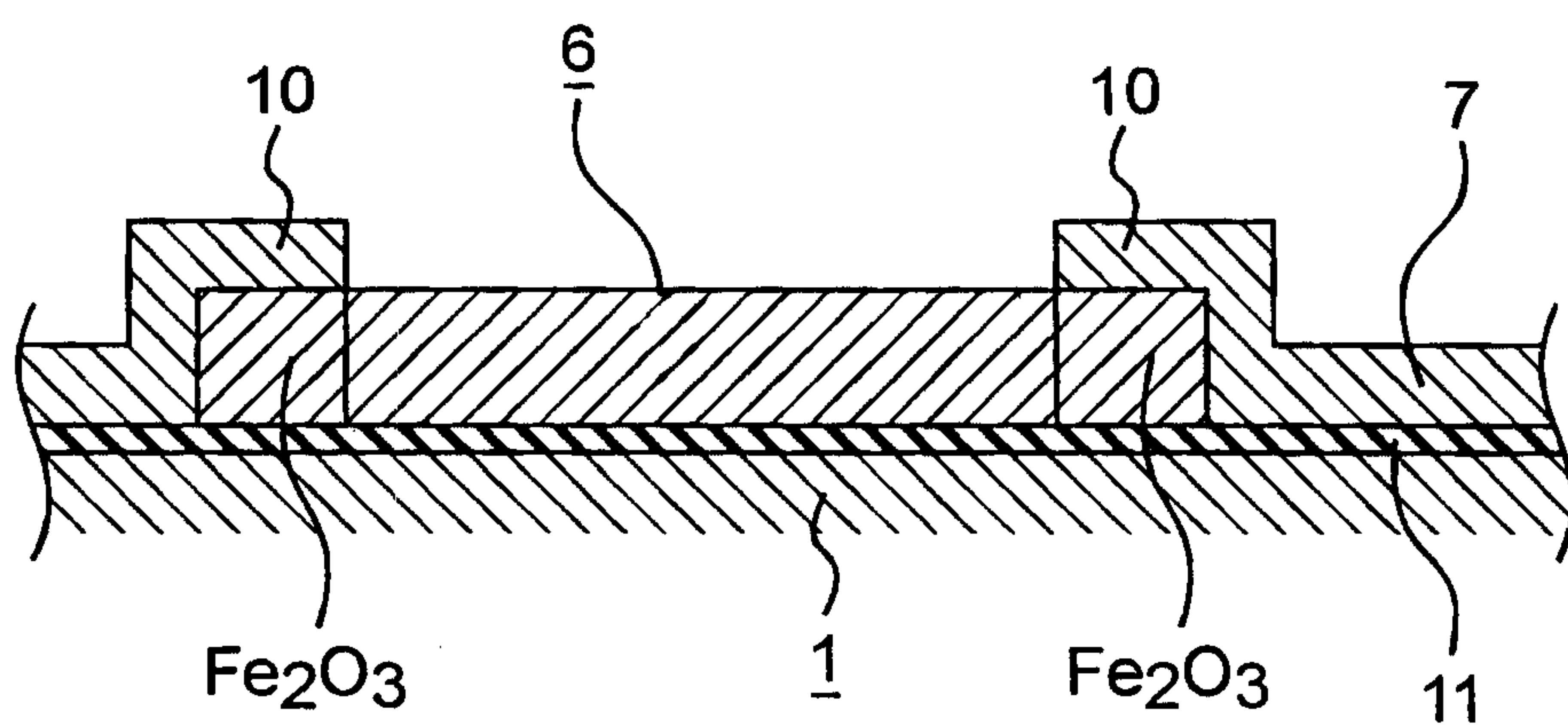

*Fig. 6*

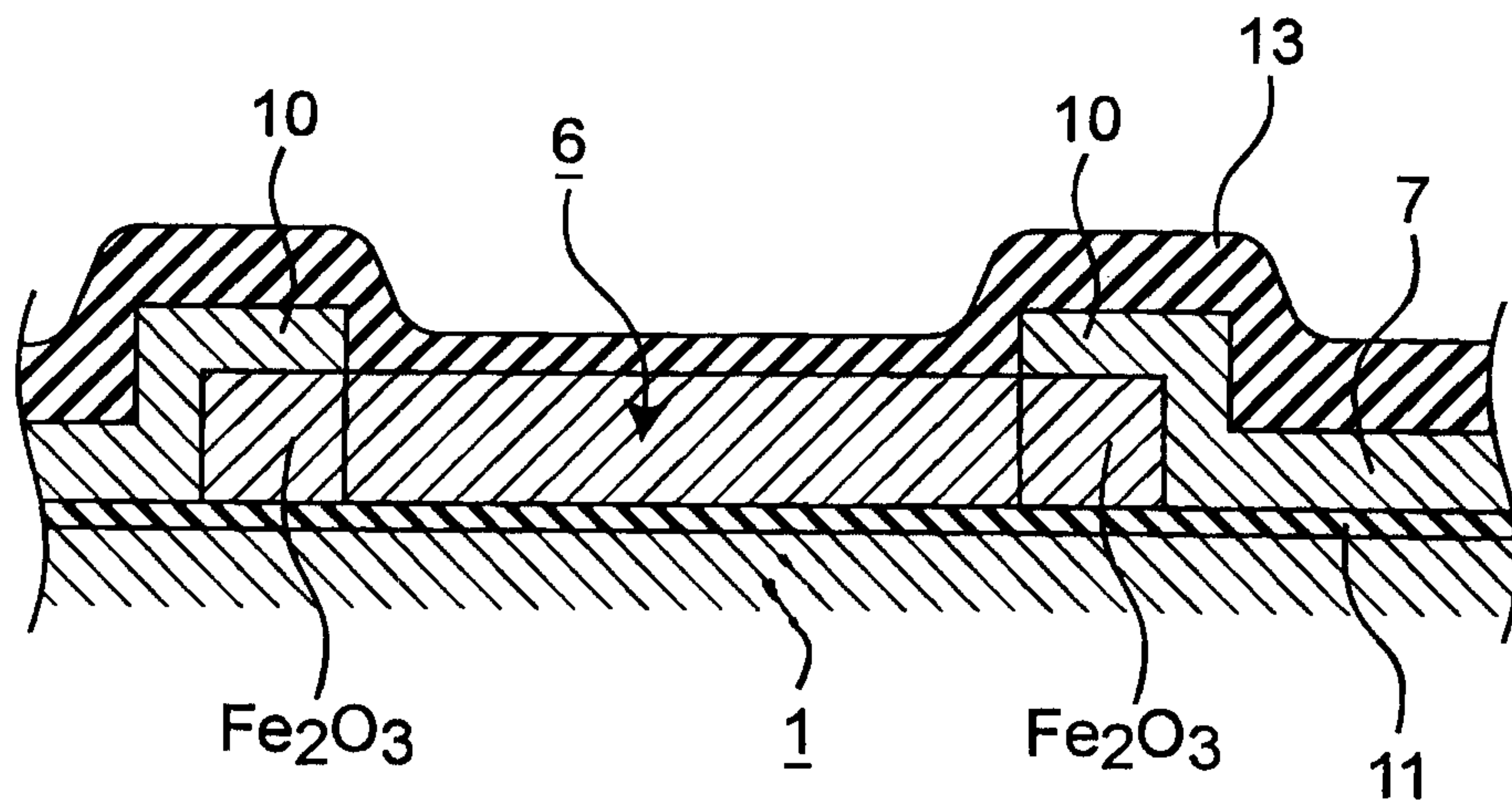

*Fig. 7*

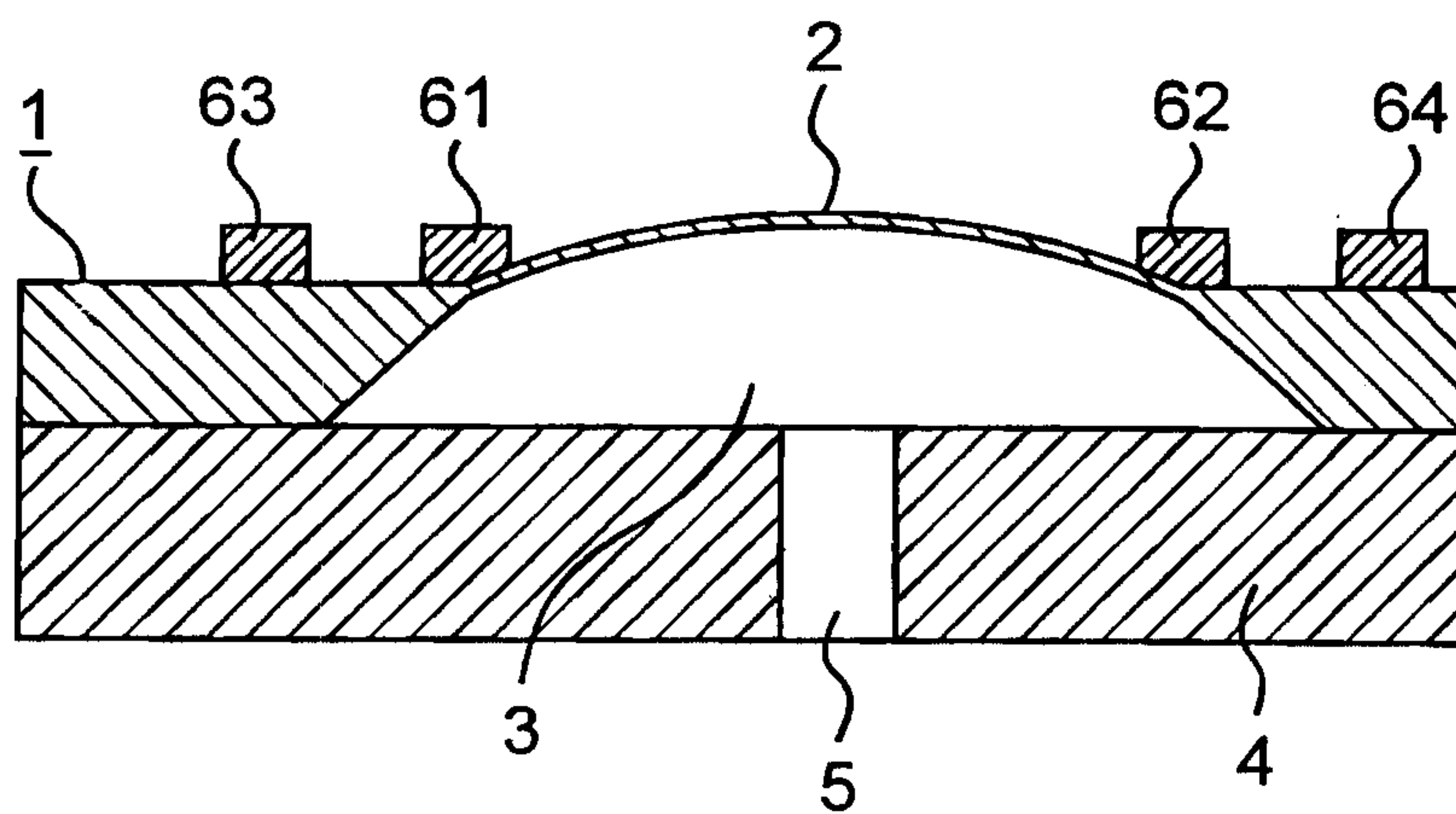



Fig. 8

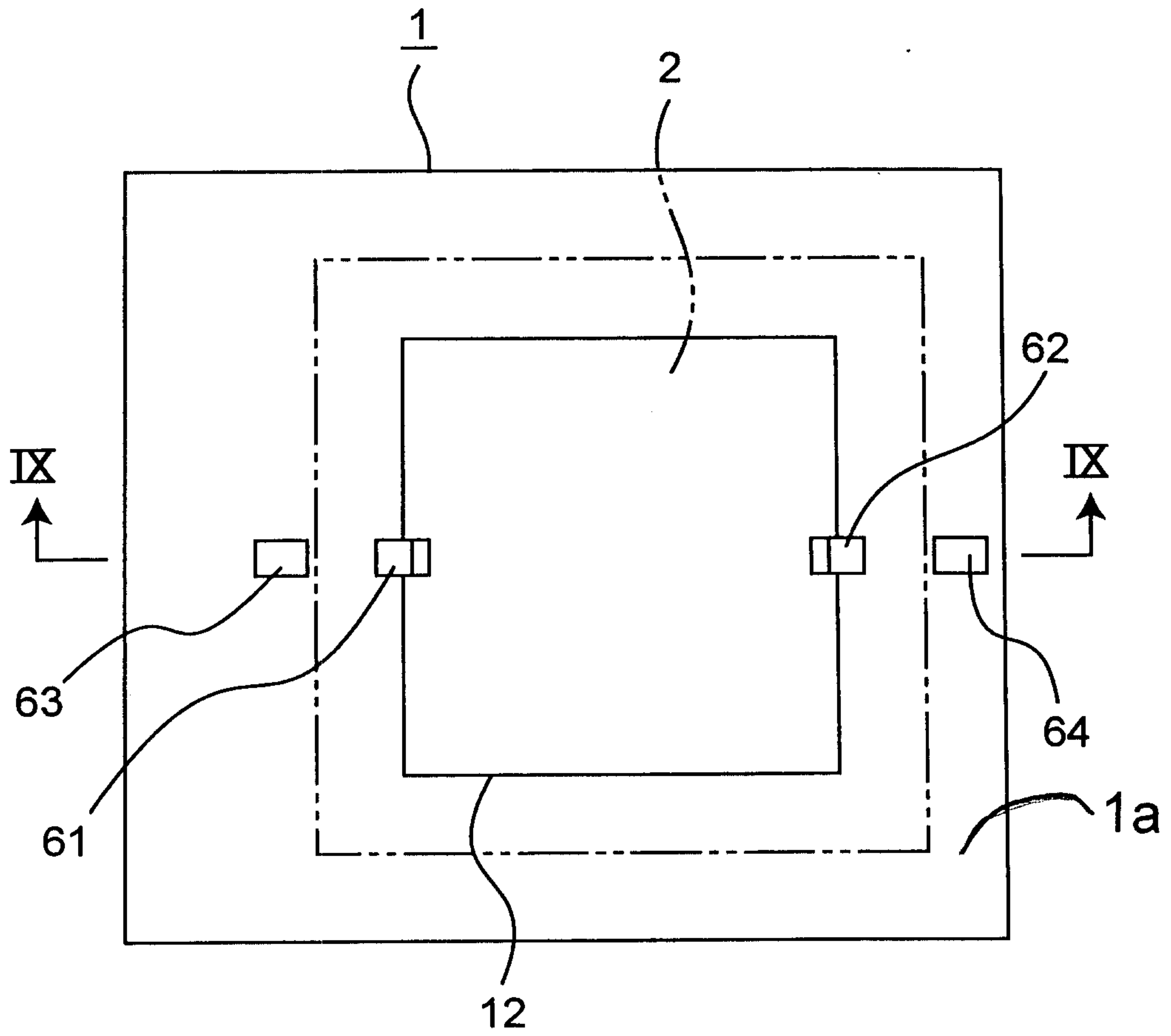
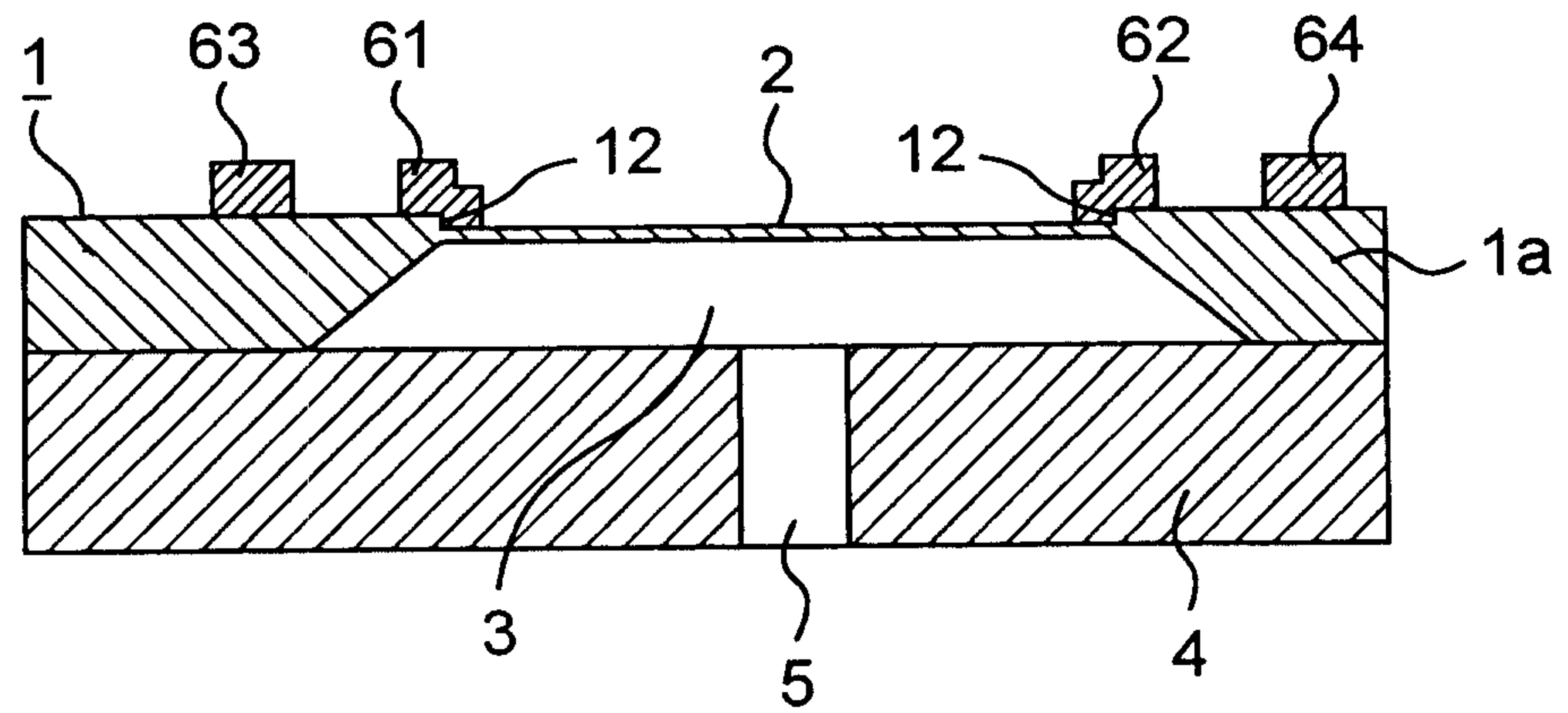

Fig. 9



*Fig. 10*

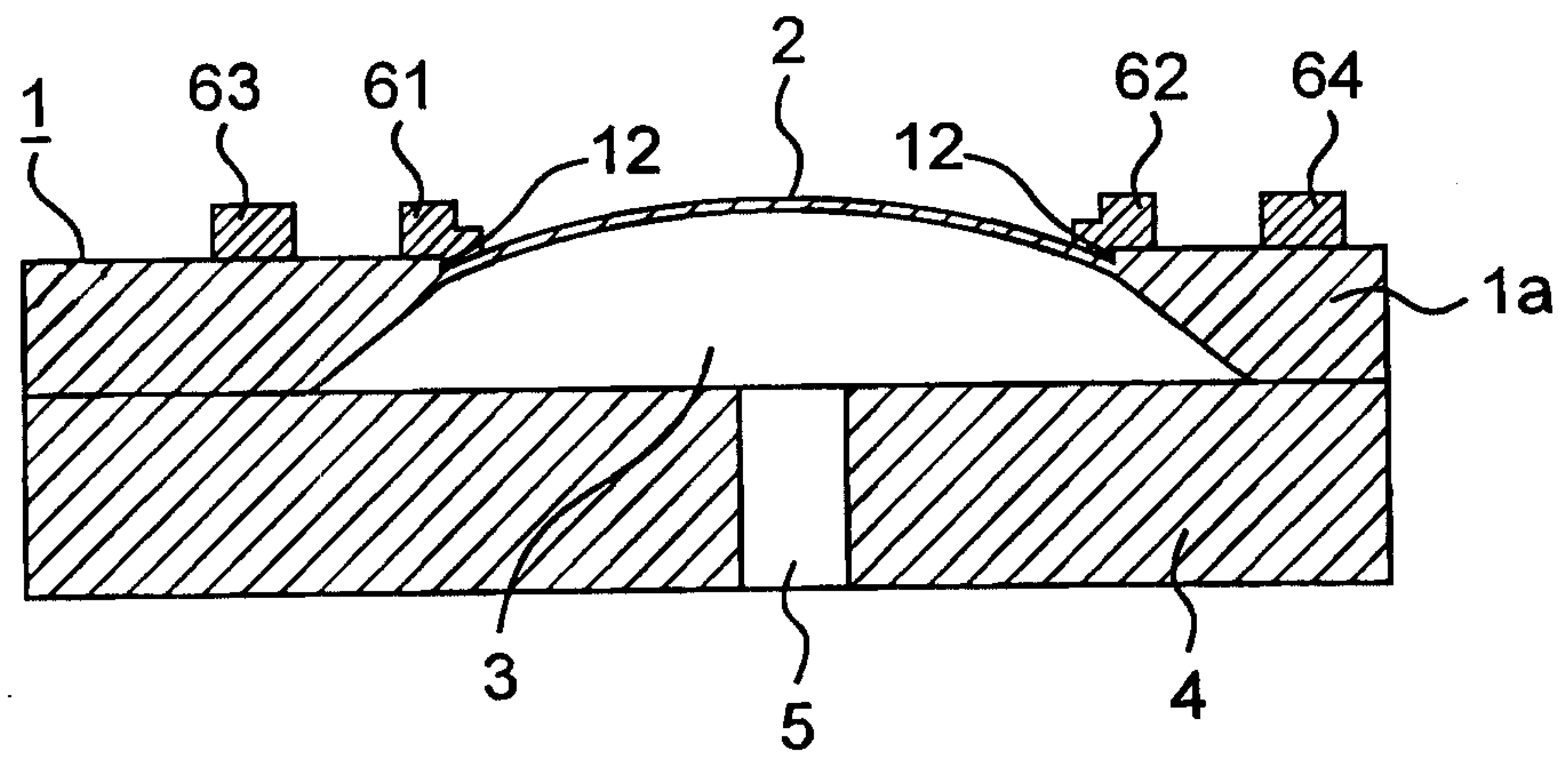

Fig. 11

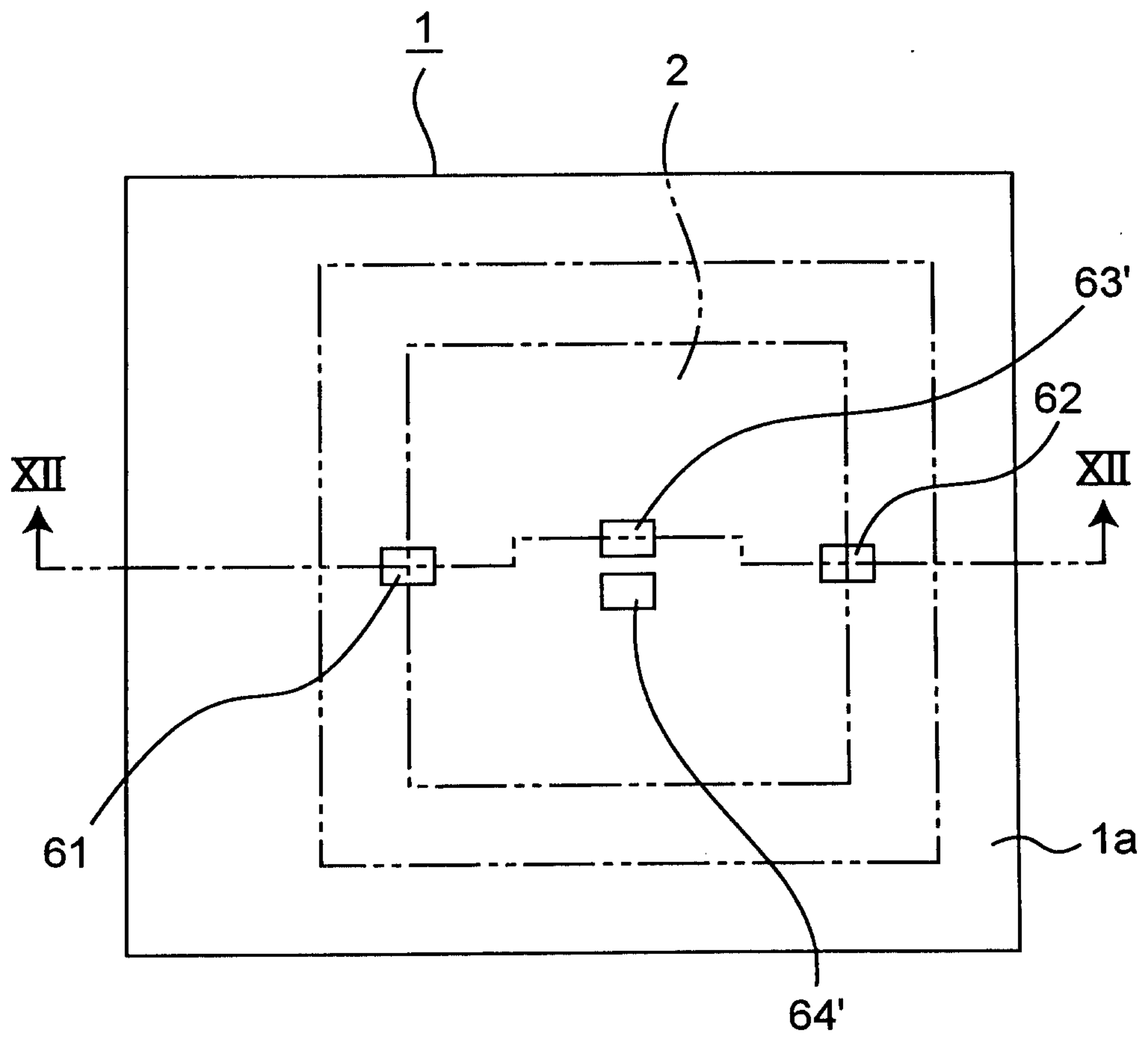

Fig. 12

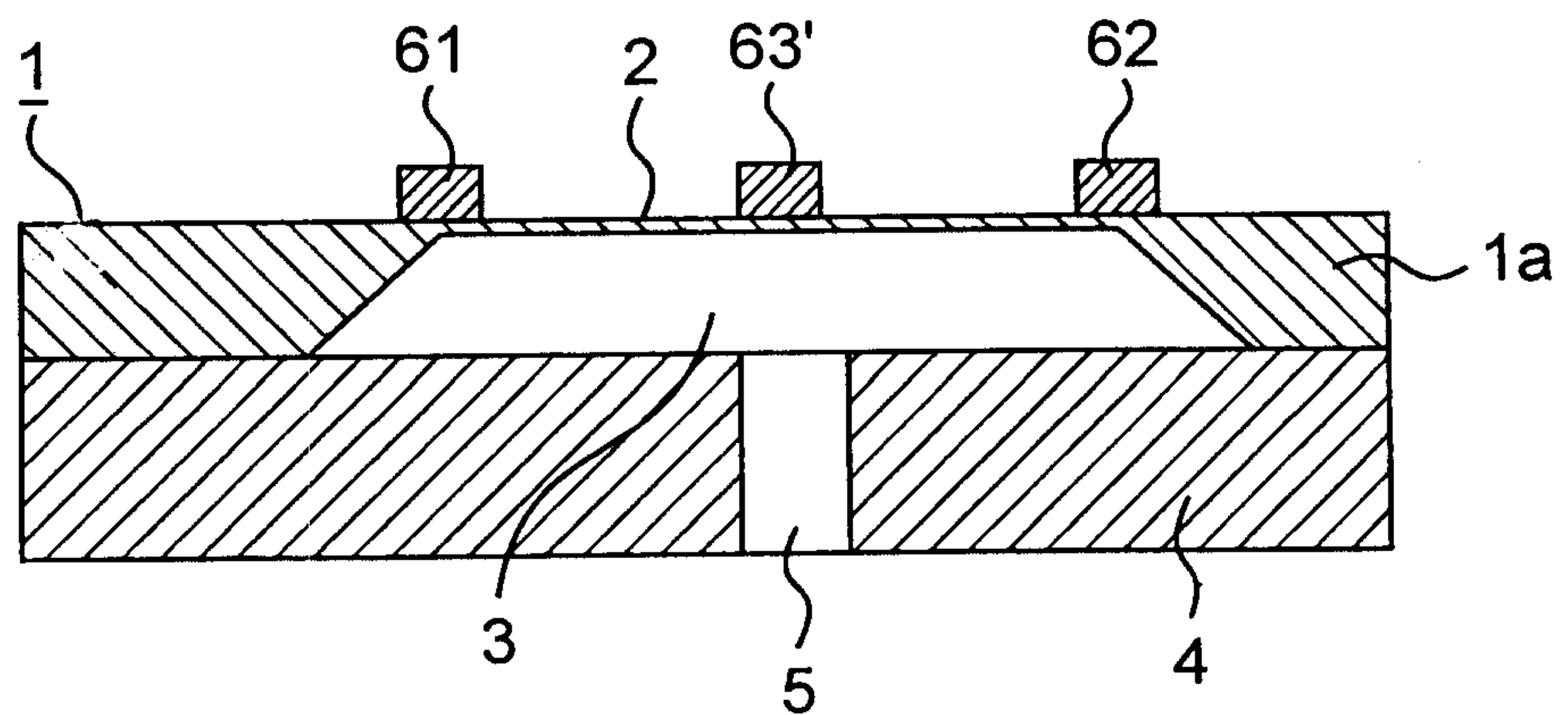



Fig. 13

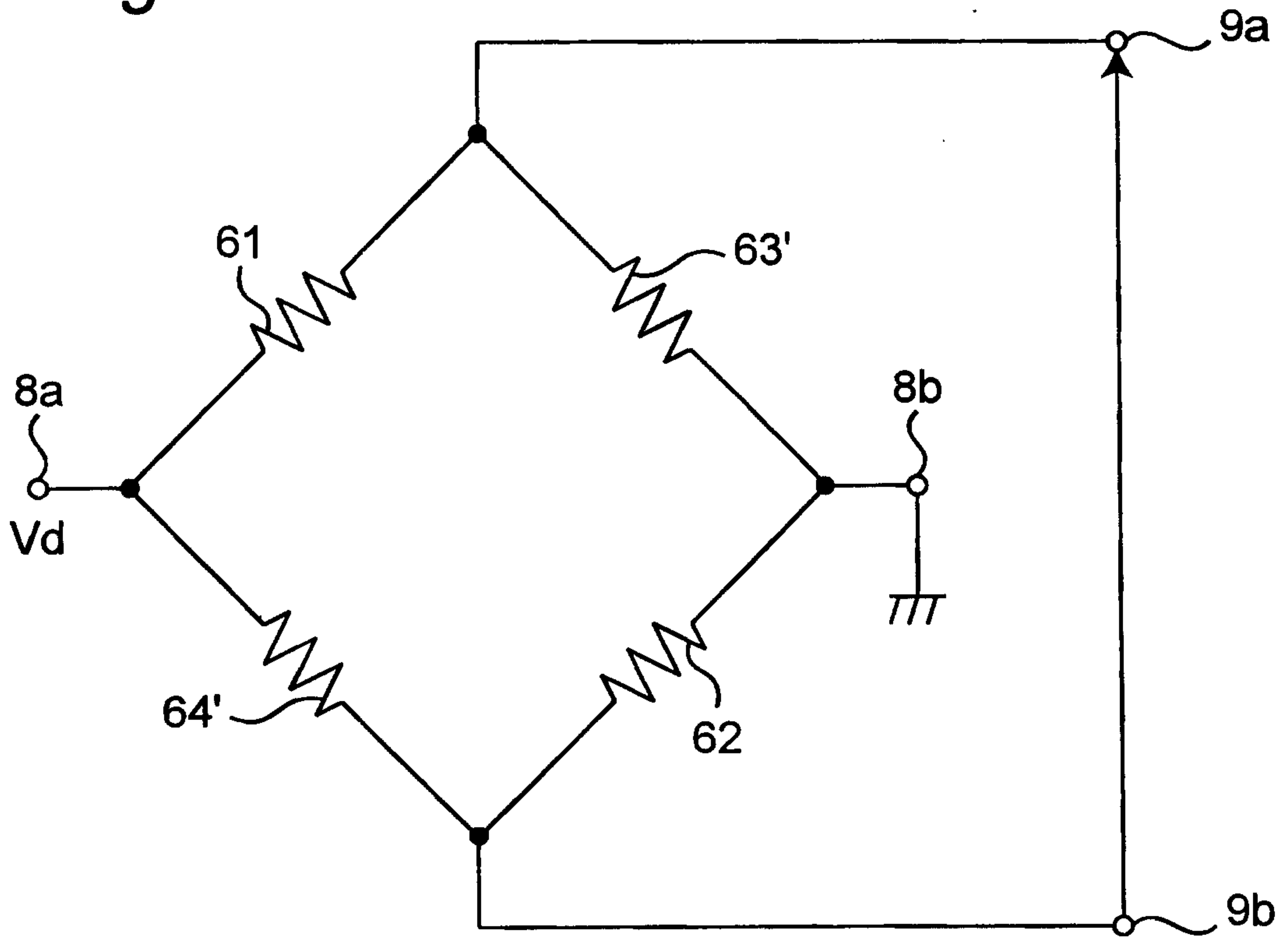
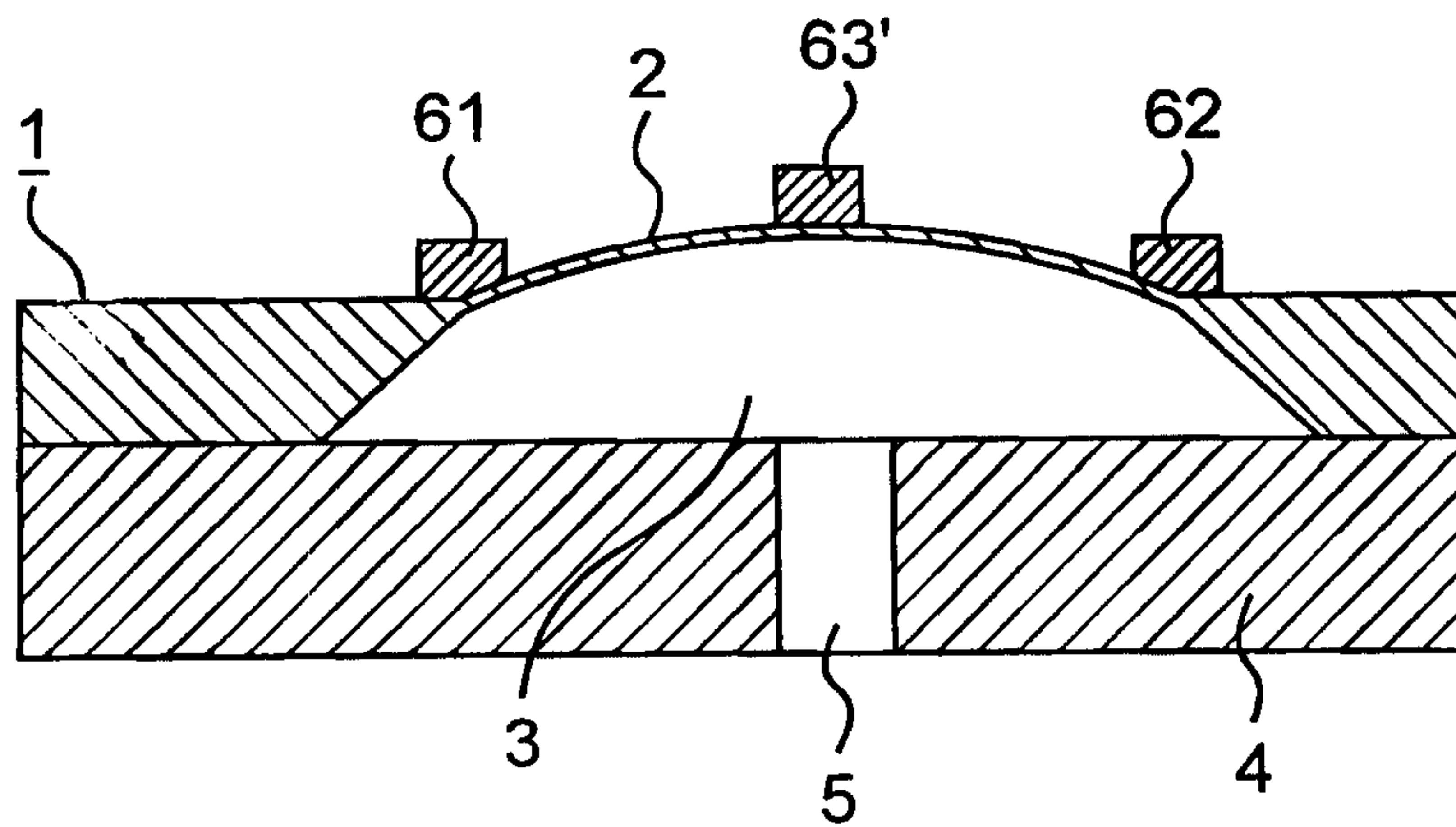
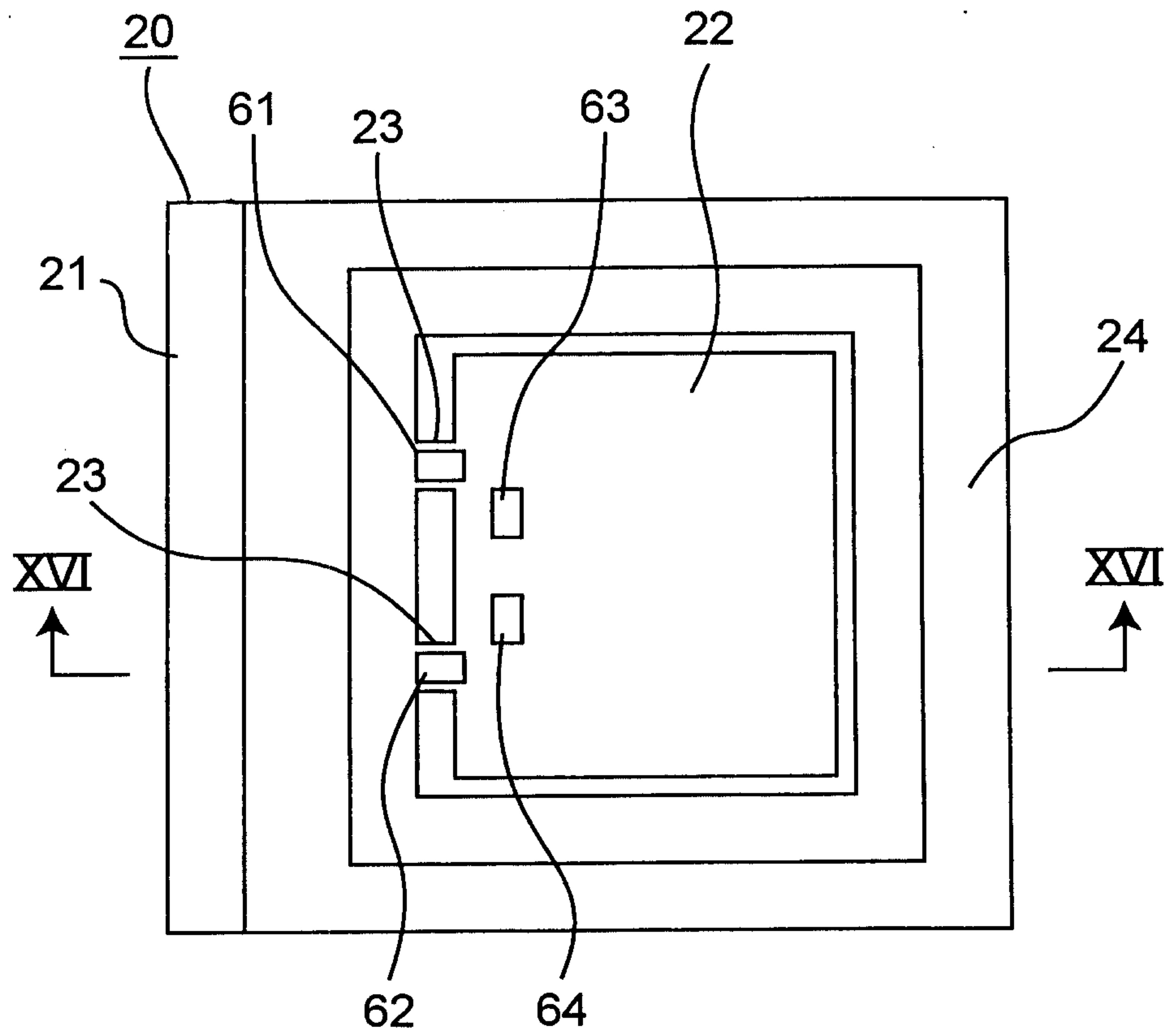

Fig. 14



*Fig. 15*



*Fig. 16*

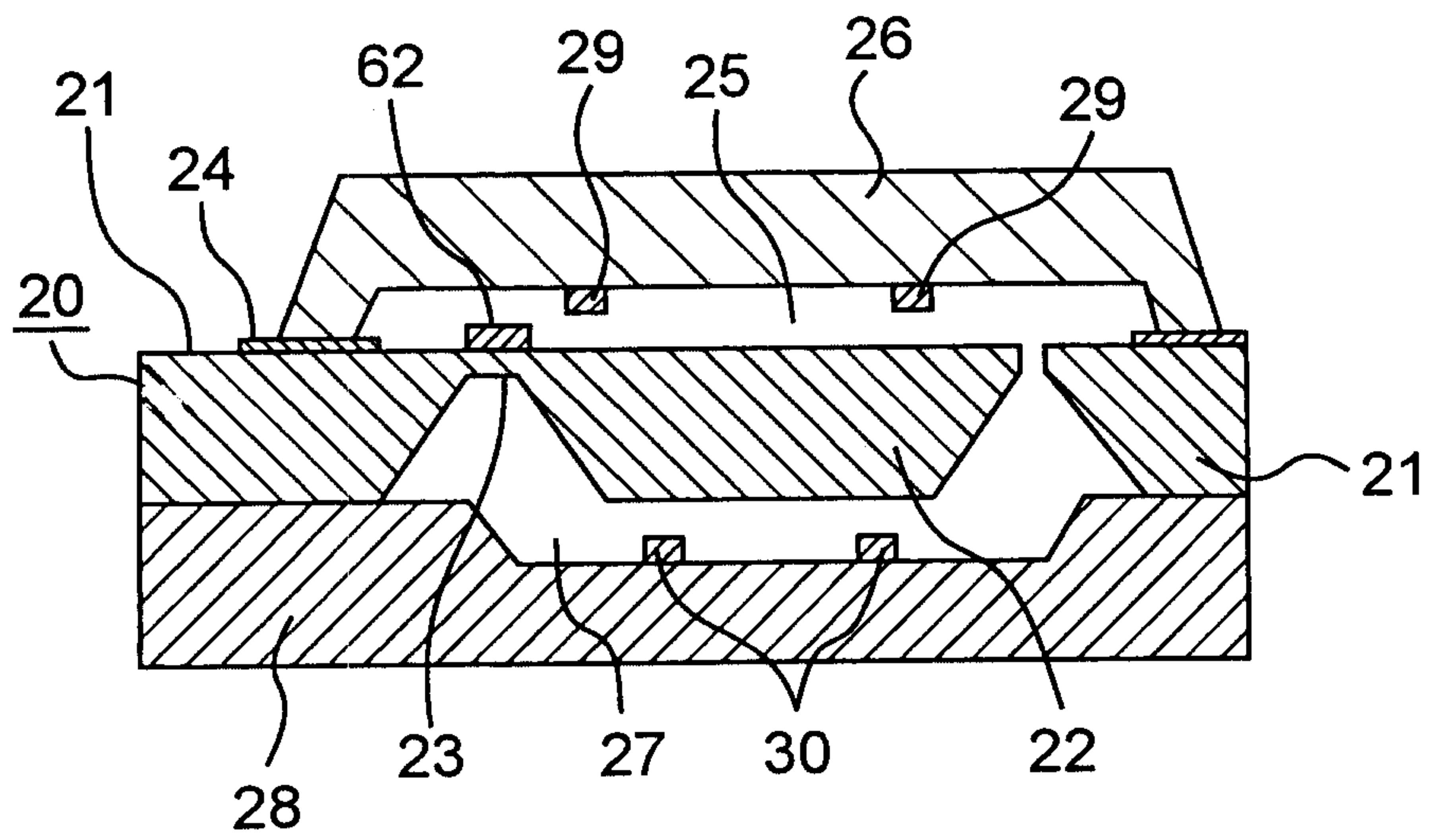

Fig. 17

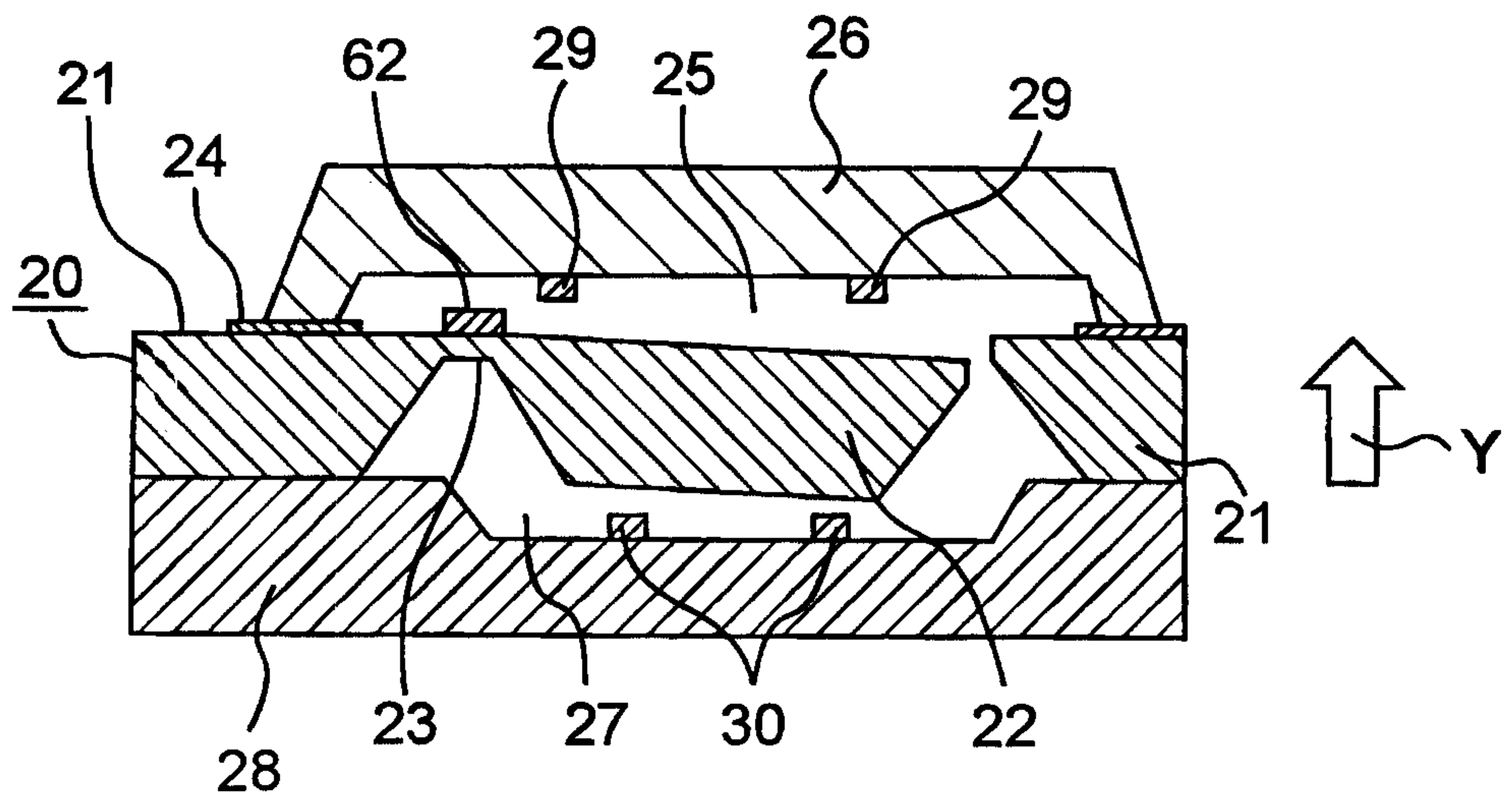
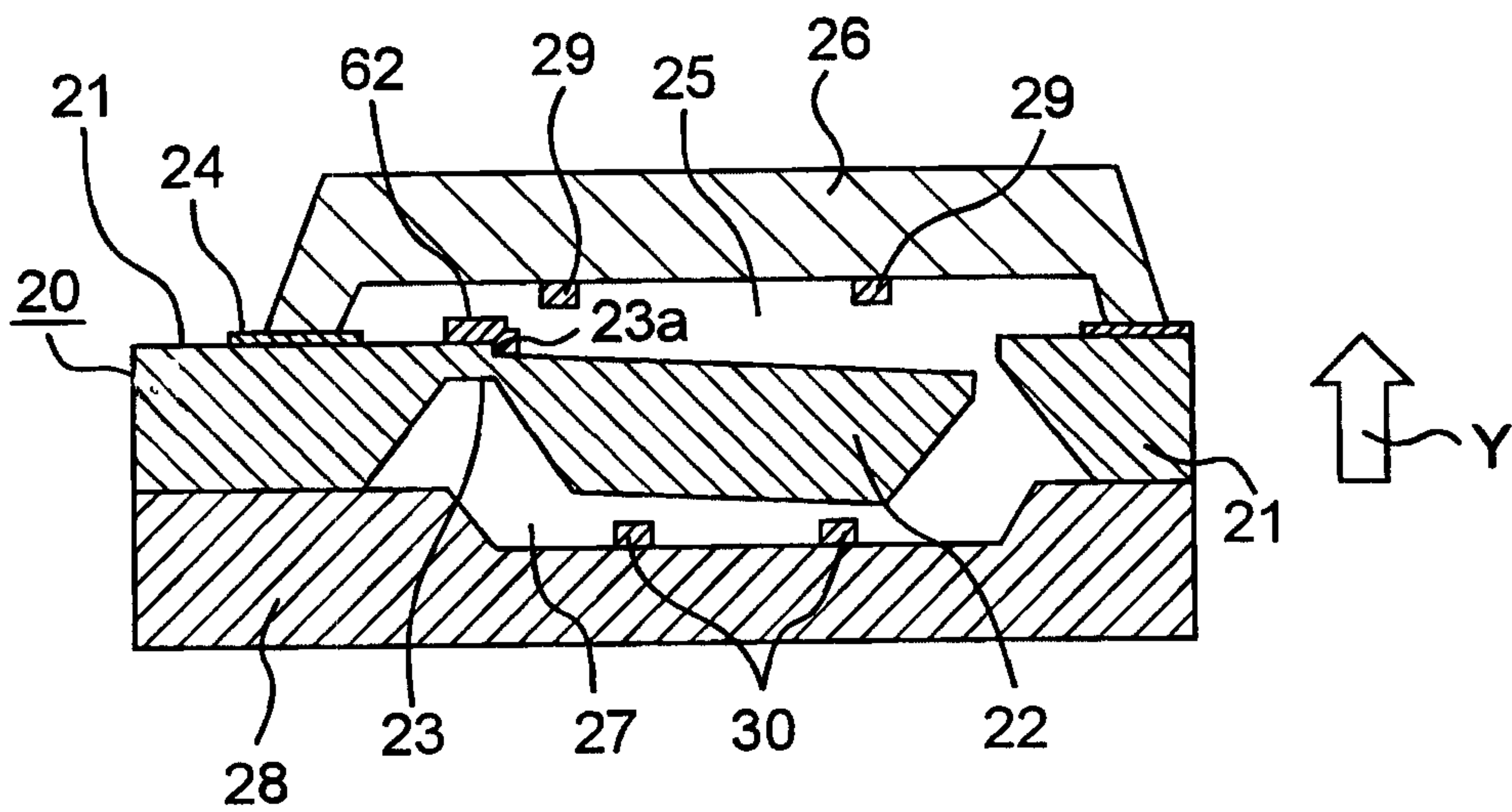
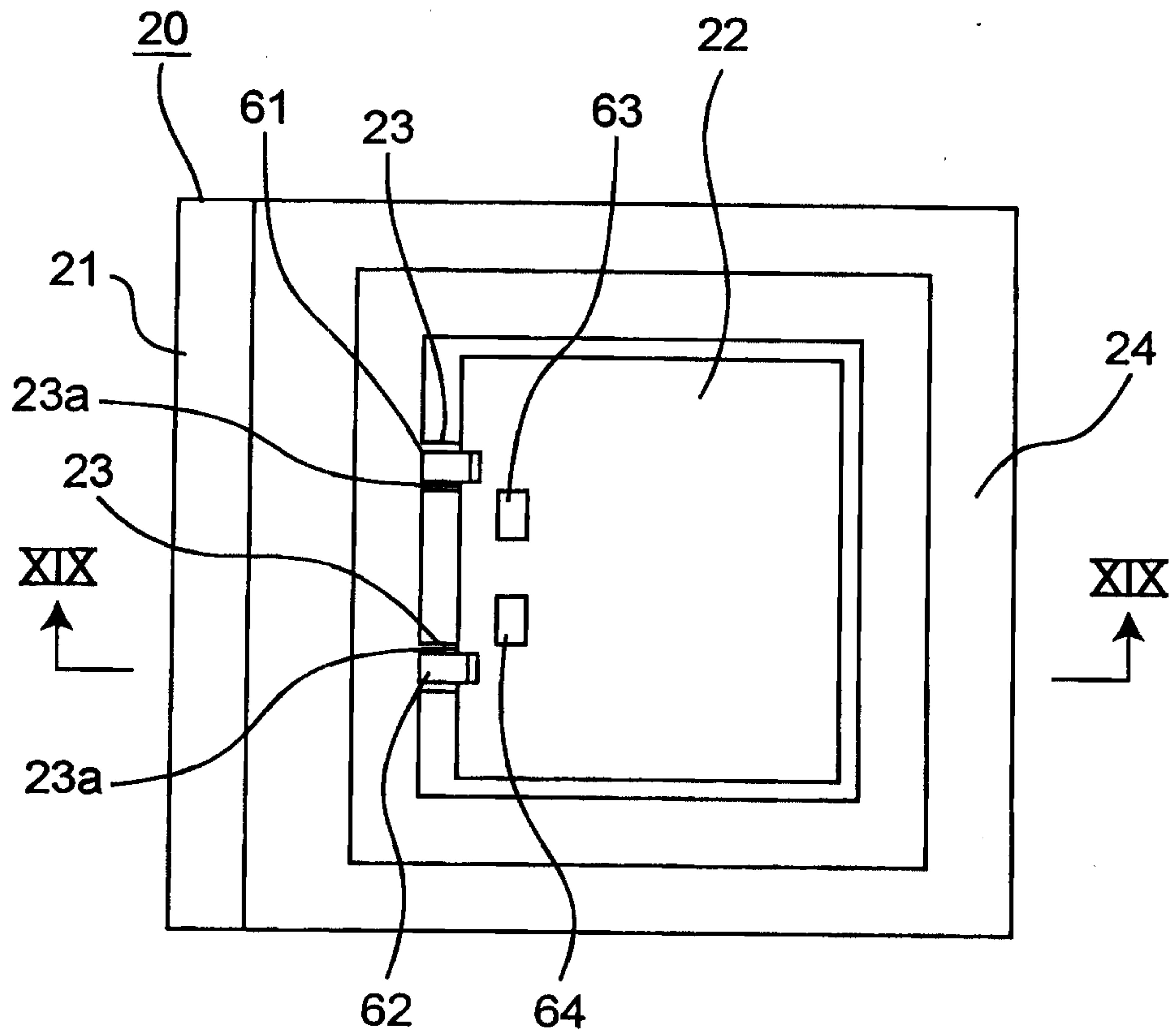



Fig. 20



**Fig. 18**



**Fig. 19**

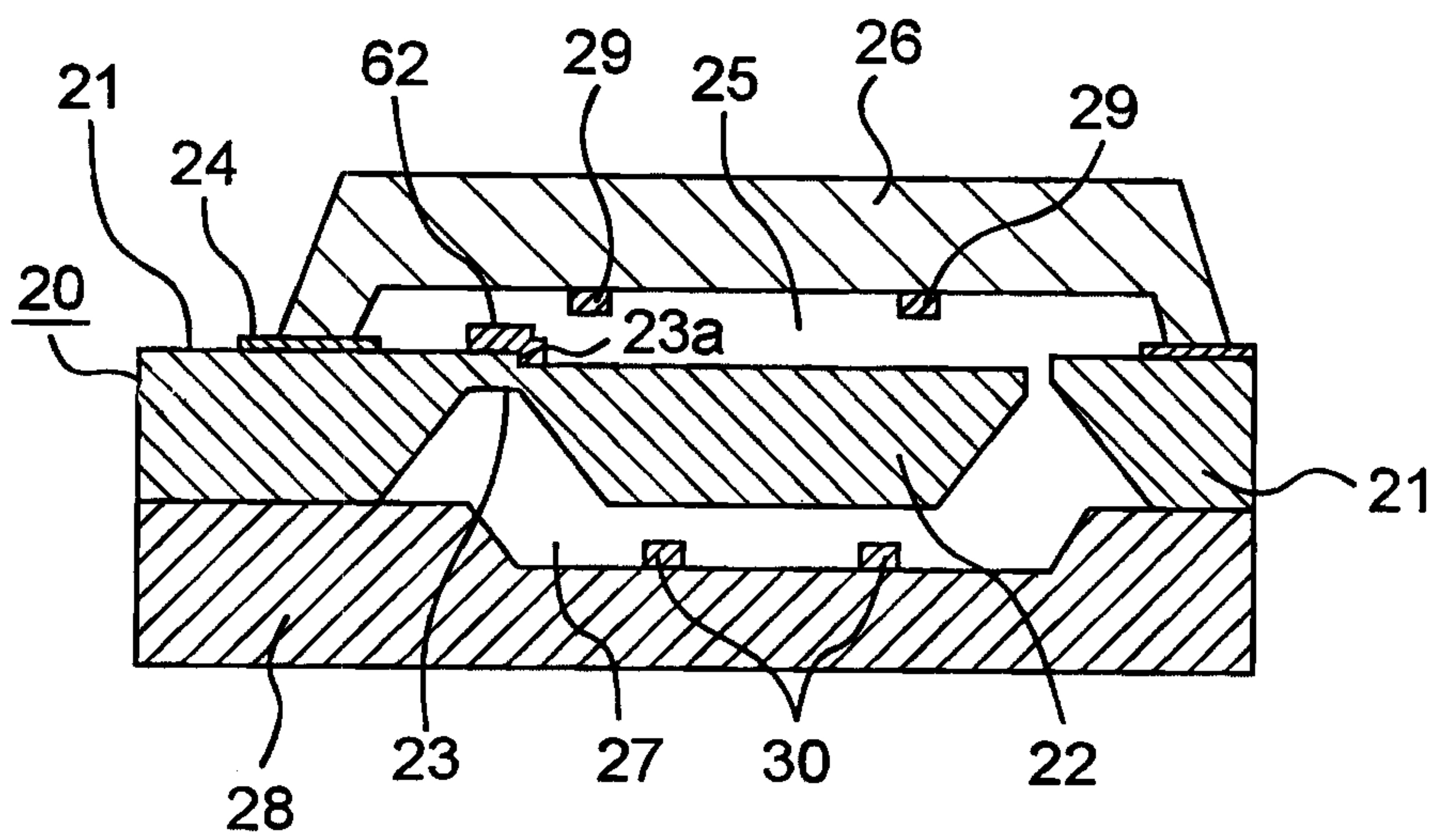

*Fig.21*

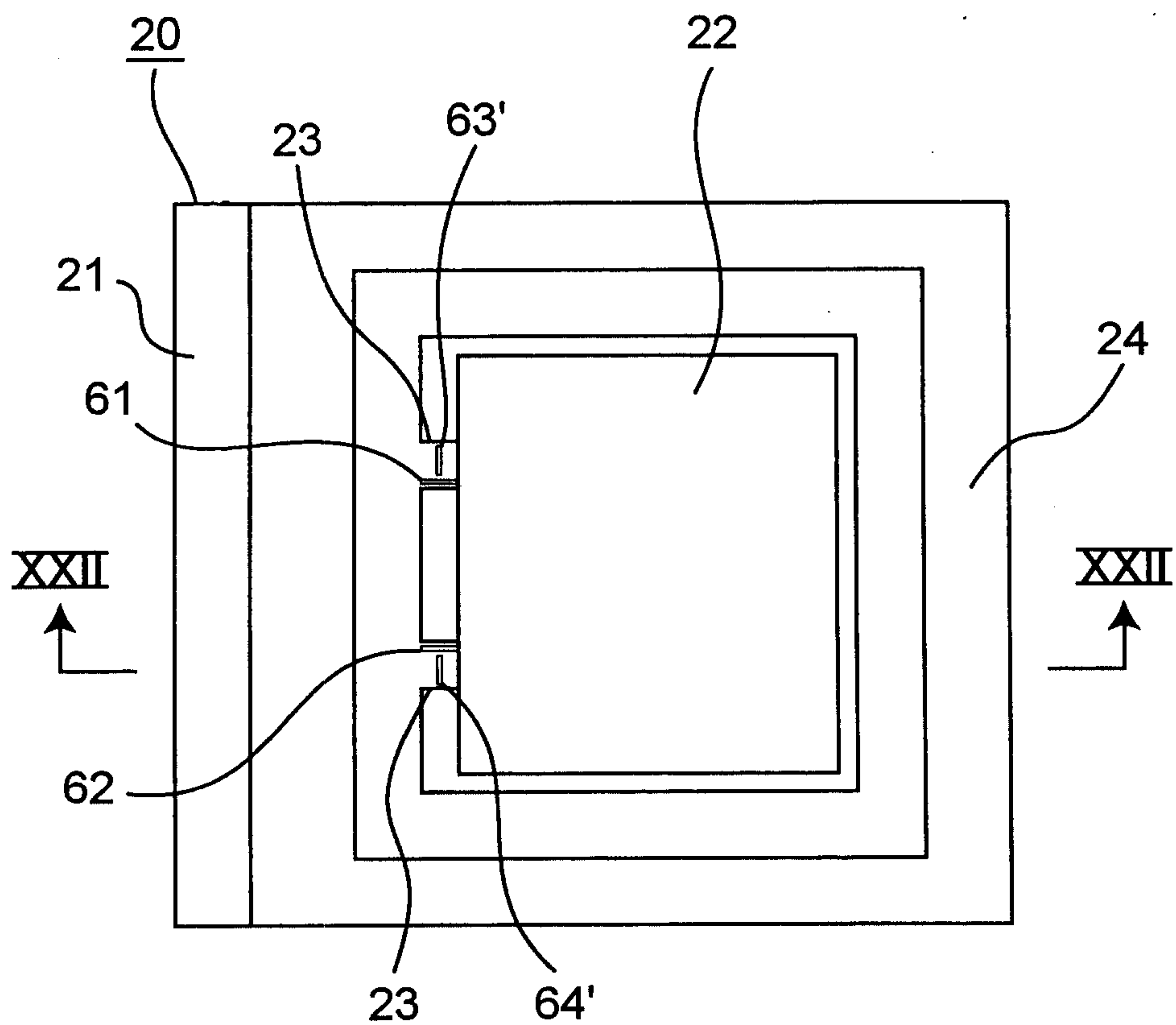

*Fig.22*

