

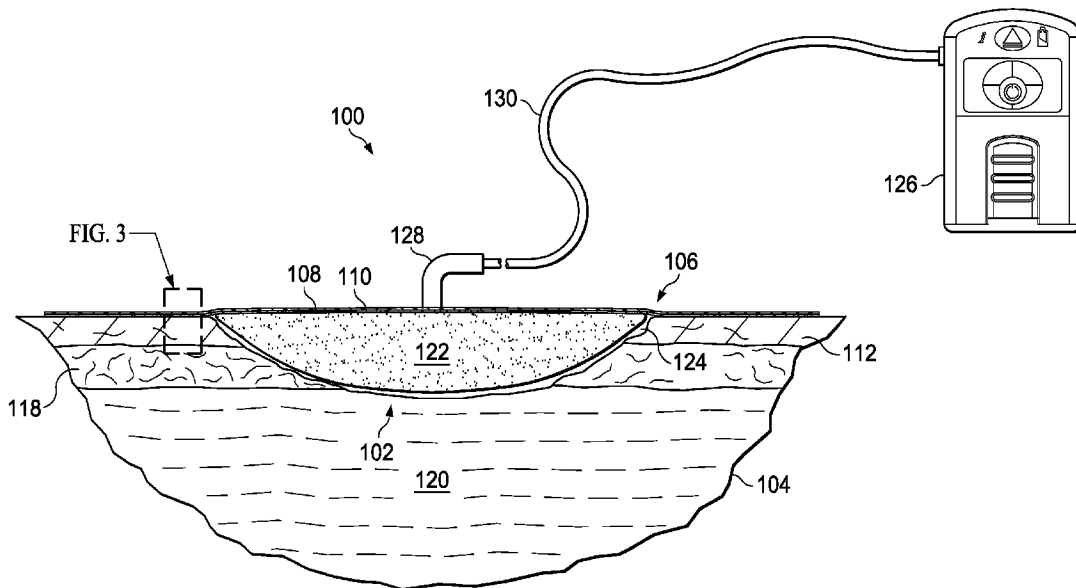

(86) Date de dépôt PCT/PCT Filing Date: 2013/11/14
 (87) Date publication PCT/PCT Publication Date: 2014/05/22
 (45) Date de délivrance/Issue Date: 2020/10/27
 (85) Entrée phase nationale/National Entry: 2015/05/15
 (86) N° demande PCT/PCT Application No.: US 2013/070070
 (87) N° publication PCT/PCT Publication No.: 2014/078518
 (30) Priorité/Priority: 2012/11/16 (US61/727,660)

(51) Cl.Int./Int.Cl. *A61F 13/00* (2006.01),
A61F 13/02 (2006.01), *A61M 1/00* (2006.01)
 (72) Inventeurs/Inventors:
LOCKE, CHRISTOPHER BRIAN, GB;
ROBINSON, TIMOTHY MARK, GB
 (73) Propriétaire/Owner:
KCI LICENSING, INC., US
 (74) Agent: BORDEN LADNER GERVAIS LLP

(54) Titre : CHAMP MEDICAL AVEC COUCHES ADHESIVES A MOTIFS ET SON PROCEDE DE FABRICATION
 (54) Title: MEDICAL DRAPE WITH PATTERN ADHESIVE LAYERS AND METHOD OF MANUFACTURING SAME



(57) **Abrégé/Abstract:**

A medical drape for use with a reduced pressure system for providing reduced pressure to a tissue site is described. In some embodiments, the drape may include a flexible film, and an adhesive layer coupled to the flexible film. The adhesive layer may include a first adhesive disposed on a first portion of the flexible film in a first pattern. The first adhesive can be configured to secure the flexible film proximate to the tissue site. The adhesive layer generally includes a second adhesive disposed on a second portion of the flexible film in a second pattern. The second adhesive can be configured to seal the flexible film proximate to the tissue site. The first pattern and the second pattern are preferably registered so that the first portion and the second portion are offset to cover substantially different portions of the flexible film.

(12) INTERNATIONAL APPLICATION PUBLISHED UNDER THE PATENT COOPERATION TREATY (PCT)

(19) World Intellectual Property
Organization
International Bureau(10) International Publication Number
WO 2014/078518 A1(43) International Publication Date
22 May 2014 (22.05.2014)

(51) International Patent Classification:

A61F 13/00 (2006.01) A61M 1/00 (2006.01)
A61F 13/02 (2006.01)

(21) International Application Number:

PCT/US2013/070070

(22) International Filing Date:

14 November 2013 (14.11.2013)

(25) Filing Language:

English

(26) Publication Language:

English

(30) Priority Data:

61/727,660 16 November 2012 (16.11.2012) US

(71) Applicant: **KCI LICENSING, INC.** [US/US]; Legal Department- Intellectual Property, P.o. Box 659508, San Antonio, TX 78265-9508 (US).(72) Inventors: **LOCKE, Christopher Brian**; 6 Bosworth Mews, Bournemouth, Dorset BH9 3SD (GB). **ROBINSON, Timothy Mark**; 27 Wellington Terrace, Basings-toke, Hampshire RG23 8HH (GB).(74) Agent: **CAUBLE, Chris M.**; SNR Denton US LLP, P.O. Box 061080, Wacker Drive Station, Willis Tower, Chicago, IL 60606 (US).

(81) Designated States (unless otherwise indicated, for every kind of national protection available): AE, AG, AL, AM, AO, AT, AU, AZ, BA, BB, BG, BH, BN, BR, BW, BY, BZ, CA, CH, CL, CN, CO, CR, CU, CZ, DE, DK, DM, DO, DZ, EC, EE, EG, ES, FI, GB, GD, GE, GH, GM, GT, HN, HR, HU, ID, IL, IN, IR, IS, JP, KE, KG, KN, KP, KR, KZ, LA, LC, LK, LR, LS, LT, LU, LY, MA, MD, ME, MG, MK, MN, MW, MX, MY, MZ, NA, NG, NI, NO, NZ, OM, PA, PE, PG, PH, PL, PT, QA, RO, RS, RU, RW, SA, SC, SD, SE, SG, SK, SL, SM, ST, SV, SY, TH, TJ, TM, TN, TR, TT, TZ, UA, UG, US, UZ, VC, VN, ZA, ZM, ZW.

(84) Designated States (unless otherwise indicated, for every kind of regional protection available): ARIPO (BW, GH, GM, KE, LR, LS, MW, MZ, NA, RW, SD, SL, SZ, TZ, UG, ZM, ZW), Eurasian (AM, AZ, BY, KG, KZ, RU, TJ, TM), European (AL, AT, BE, BG, CH, CY, CZ, DE, DK, EE, ES, FI, FR, GB, GR, HR, HU, IE, IS, IT, LT, LU, LV, MC, MK, MT, NL, NO, PL, PT, RO, RS, SE, SI, SK, SM, TR), OAPI (BF, BJ, CF, CG, CI, CM, GA, GN, GQ, GW, KM, ML, MR, NE, SN, TD, TG).

Published:

— with international search report (Art. 21(3))

(54) Title: MEDICAL DRAPE WITH PATTERN ADHESIVE LAYERS AND METHOD OF MANUFACTURING SAME

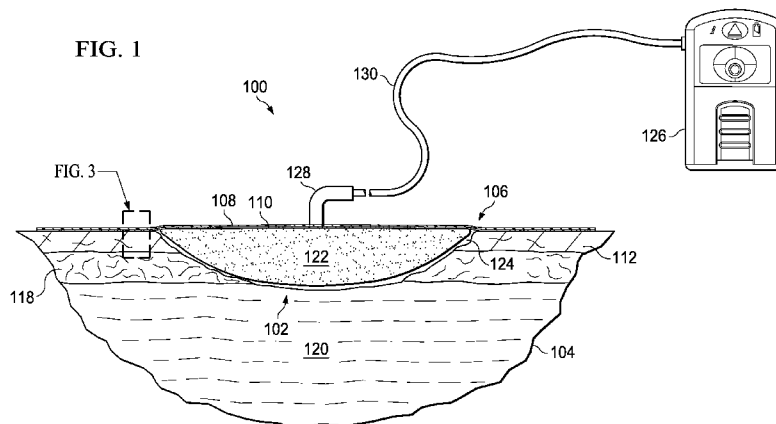

(57) Abstract: A medical drape for use with a reduced pressure system for providing reduced pressure to a tissue site is described. In some embodiments, the drape may include a flexible film, and an adhesive layer coupled to the flexible film. The adhesive layer may include a first adhesive disposed on a first portion of the flexible film in a first pattern. The first adhesive can be configured to secure the flexible film proximate to the tissue site. The adhesive layer generally includes a second adhesive disposed on a second portion of the flexible film in a second pattern. The second adhesive can be configured to seal the flexible film proximate to the tissue site. The first pattern and the second pattern are preferably registered so that the first portion and the second portion are offset to cover substantially different portions of the flexible film.



WO 2014/078518 A1

MEDICAL DRAPE WITH PATTERN ADHESIVE LAYERS AND METHOD OF MANUFACTURING SAME

[0001] 

FIELD

[0002] The present disclosure relates generally to dressings for adhering to a patient, and more particularly, but without limitation to, a medical drape having patterned adhesive layers deposited thereon and methods to manufacture the same.

BACKGROUND

[0003] Clinical studies and practice have shown that reducing pressure in proximity to a tissue site can augment and accelerate growth of new tissue at the tissue site. The applications of this phenomenon are numerous, but it has proven particularly advantageous for treating wounds. Regardless of the etiology of a wound, whether trauma, surgery, or another cause, proper care of the wound is important to the outcome. Treatment of wounds with reduced pressure is commonly referred to as “reduced-pressure therapy,” but may also be known by other names, including “negative pressure wound therapy” and “vacuum therapy,” for example. Reduced-pressure therapy may provide a number of benefits, including migration of epithelial and subcutaneous tissues, improved blood flow, and micro-deformation of tissue at a wound site. Together, these benefits can increase development of granulation tissue and reduce healing times.

[0004] While the clinical benefits of reduced-pressure therapy are widely known, the cost and complexity of reduced-pressure therapy can be a limiting factor in its application, and the development and operation of reduced-pressure systems, components, and processes continues to present significant challenges to manufacturers, healthcare providers, and patients.

SUMMARY

[0005] According to an illustrative, non-limiting embodiment, a medical drape is described. The medical drape may include a flexible film and a first adhesive disposed on a first portion of the flexible film in a first pattern. The medical drape may also include a second adhesive disposed on a second portion of the flexible film in a second pattern. The second pattern may be registered with the first pattern so that the first portion and the second portion cover substantially different portions of the flexible film.

[0006] According to another illustrative embodiment, a system for treating a tissue site with reduced pressure is described. The system may include a manifold for distributing reduced pressure proximate to a tissue site and a reduced-pressure source fluidly coupled to the manifold. The system may also include a drape. The drape may include a first adhesive and a second adhesive coupled to the drape. The second adhesive may be registered with the first adhesive so that the first adhesive and the second adhesive cover substantially different portions of the drape.

[0007] According to yet another illustrative embodiment, a method of manufacturing a medical drape is disclosed. The method provides a flexible film and disposes a first adhesive on a side of the flexible film in a first pattern. The method also disposes a second adhesive on the side of the flexible film in a second pattern. The first adhesive and the second adhesive cover substantially different portions of the flexible film. The second adhesive may have a tackiness less than a tackiness of the first adhesive.

[0008] According to still another illustrative embodiment, a method for treating a tissue site with reduced pressure is disclosed. The method disposes a manifold for distributing reduced pressure proximate to a tissue site and fluidly couples a reduced-pressure source to the manifold. The method disposes a medical drape over the tissue site. The medical drape may have a first adhesive and a second adhesive coupled to the medical drape. The second adhesive may be registered with the first adhesive so that the first and second adhesives cover substantially different portions of the medical drape. The method applies the second adhesive to the tissue site to form a sealing coupling between the drape and the tissue site. The method positions the drape. The method applies a force to the first adhesive to form a bonding coupling between the drape and the tissue site.

[0009] Other aspects, features, and advantages of the illustrative embodiments will become apparent with reference to the drawings and detailed description that follow.

BRIEF DESCRIPTION OF THE DRAWINGS

[0010] Illustrative embodiments are described in detail below with reference to the attached drawings, which are incorporated by reference herein, and wherein:

[0011] Figure 1 is a schematic, diagram (with a portion shown in elevation) of an illustrative embodiment of a system for treating a tissue site on a patient with reduced pressure that may be associated with some illustrative embodiments of the system;

[0012] Figure 2 is an exploded, perspective view of an illustrative embodiment of a medical drape;

[0013] Figure 3A is an exploded view in cross section of a portion of the system of Figure 1;

[0014] Figure 3B is an assembled view in cross section of the portion of Figure 3A with sealing couplings;

[0015] Figure 3B is an assembled view in cross section of the portion of Figure 3A with contact couplings;

[0016] Figure 4A is a plan view of the medical drape and a portion of an adhesive layer of Figure 2 having a bonding adhesive disposed thereon;

[0017] Figure 4B is a plan view of the medical drape and the adhesive layer of Figure 2 having the bonding adhesive and a sealing adhesive disposed thereon;

[0018] Figure 5A is a plan view of the medical drape and a portion of the adhesive layer of Figure 2 having a bonding adhesive disposed thereon;

[0019] Figure 5B is a plan view of the medical drape and a portion of the adhesive layer of Figure 2 having a sealing adhesive disposed thereon;

[0020] Figure 5C is a plan view of the medical drape and the adhesive layer of Figure 2 having the bonding adhesive of Figure 5A and the sealing adhesive of Figure 5B disposed thereon;

[0021] Figure 6A is a plan view of the medical drape and a portion of the adhesive layer of Figure 2 having a bonding adhesive disposed thereon;

[0022] Figure 6B is a plan view of the medical drape and a portion of the adhesive layer of Figure 2 having a sealing adhesive disposed thereon;

[0023] Figure 6C is a plan view of the medical drape and the adhesive layer of Figure 2 having the bonding adhesive of Figure 6A and the sealing adhesive of Figure 6B disposed thereon;

[0024] Figure 7A is a schematic diagram of an illustrative screen apparatus for manufacturing the medical drape of Figure 2;

[0025] Figure 7B is a schematic diagram of a portion of an exterior surface of a first rotary screen of Figure 7A;

[0026] Figure 7C is a schematic diagram of a portion of an exterior surface of a second rotary screen of Figure 7A;

[0027] Figure 8A is a schematic diagram of an illustrative transfer apparatus for manufacturing the medical drape of Figure 2;

[0028] Figure 8B is a schematic diagram of a portion of an exterior surface of a first transfer cylinder of Figure 8A;

[0029] Figure 8C is a schematic diagram of a portion of an exterior surface of a second transfer cylinder of Figure 8A;

[0030] Figure 8D is a schematic diagram of a portion of another exterior surface of a first transfer cylinder of Figure 8A;

[0031] Figure 8E is a schematic view of a portion of another exterior surface of a second transfer cylinder of Figure 8A;

[0032] Figure 9A is a schematic diagram of an illustrative extrusion apparatus for manufacturing the medical drape of Figure 2;

[0033] Figure 9B is a cross sectional view taken along line 9B—9B of Figure 9A, illustrating the manufacture of an adhesive layer of the medical drape of Figure 2 using the system of Figure 9A;

[0034] Figure 10A is a schematic diagram of an illustrative extrusion apparatus for manufacturing the medical drape of Figure 2; and

[0035] Figure 10B is a cross sectional view taken along line 10B—10B of Figure 10A, illustrating the manufacture of an adhesive layer of the medical drape of Figure 2 using the system of Figure 10A.

DETAILED DESCRIPTION

[0036] New and useful systems, methods, and apparatuses associated with medical drapes used for regulating pressure are set forth in the appended claims. Objectives, advantages, and a preferred mode of making and using the systems, methods, and apparatuses may be understood best by reference to the following detailed description in conjunction with the accompanying drawings. The description provides information that enables a person skilled in the art to make and use the claimed subject matter, but may omit certain details already well-known in the art. Moreover, descriptions of various alternatives using terms such as “or” do not necessarily require mutual exclusivity unless clearly required by the context. The claimed subject matter may also encompass alternative embodiments, variations, and equivalents not specifically described in detail. The following detailed description should therefore be taken as illustrative and not limiting.

[0037] Figure 1 is a sectional view of a system 100 for treating a tissue site 102 with a reduced pressure illustrating details that may be associated with some embodiments. The system 100 may include a drape, such as a medical drape 106, which may be attached to an epidermis 112. The medical drape 106 can substantially prevent the leakage of fluids while allowing vapor to egress through medical drape 106. The medical drape 106 can maintain an adequately strong mechanical connection to the epidermis 112 during operation, but may be detached with minimal or substantially reduced pain.

[0038] In general, components of the reduced-pressure therapy system 100 may be coupled directly or indirectly. For example, the reduced-pressure source 126 may be directly coupled to the reduced-pressure interface 128 and indirectly coupled to the tissue site 102 through the reduce-pressure interface 128. Components may be fluidly coupled to each other to provide a path for transferring fluids (i.e., liquid and/or gas) between the components. In some embodiments, components may be fluidly coupled with a tube, for example. A “tube,” as used herein, broadly refers to a tube, pipe, hose, conduit, or other structure with one or more lumina adapted to convey fluids between two ends. Typically, a tube is an elongated, cylindrical structure with some flexibility, but the geometry and rigidity may vary. In some embodiments, components may additionally or alternatively be coupled by virtue of physical proximity, being integral to a single structure, or being formed from the same piece of material. Coupling may also include mechanical, thermal, electrical, or chemical coupling (such as a chemical bond) in some contexts.

[0039] In operation, a tissue interface, such as the manifold 122, may be placed within, over, on, against, or otherwise adjacent to a tissue site. For example, the manifold 122 may be placed against a tissue site, and the medical drape 106 may be placed over the manifold 122 and sealed to tissue proximate to the tissue site. Tissue proximate to a tissue site is often undamaged epidermis peripheral to the tissue site. Thus, the drape 108 can provide a sealed therapeutic environment 124 proximate to the tissue site. The sealed therapeutic environment 124 may be substantially isolated from the external environment, and the reduced-pressure source 126 can reduce the pressure in the sealed therapeutic environment 124. Reduced pressure applied uniformly through the tissue interface in the sealed therapeutic environment 124 can induce macrostrain and microstrain in the tissue site, as well as remove exudates and other fluids from the tissue site. The removed exudates and other fluids can be collected in a container and disposed of properly.

[0040] The fluid mechanics of using a reduced-pressure source to reduce pressure in another component or location, such as within a sealed therapeutic environment 124, can be mathematically complex. However, the basic principles of fluid mechanics applicable to reduced-pressure therapy are generally well-known to those skilled in the art, and the process of reducing pressure may be described illustratively herein as “delivering,” “distributing,” or “generating” reduced pressure, for example.

[0041] In general, exudates and other fluids flow toward lower pressure along a fluid path. This orientation is generally presumed for purposes of describing various features and components of reduced-pressure therapy systems herein. Thus, in the context of reduced-pressure therapy, the term “downstream” typically implies something in a fluid path relatively closer to a reduced-pressure source, and conversely, the term “upstream” implies something relatively further away from a reduced-pressure source. Similarly, it may be convenient to describe certain features in terms of fluid “inlet” or “outlet” in such a frame of reference. However, a fluid path may also be reversed in some applications, such as by substituting a positive-pressure source, and this descriptive convention should not be construed as a limiting convention.

[0042] The term “tissue site” in this context broadly refers to a wound or defect located on or within tissue, including but not limited to, bone tissue, adipose tissue, muscle tissue, neural tissue, dermal tissue, vascular tissue, connective tissue, cartilage, tendons, or ligaments. A wound may include chronic, acute, traumatic, subacute, and dehisced wounds, partial-thickness burns, ulcers (such as diabetic, pressure, or venous insufficiency ulcers),

flaps, and grafts, for example. The term “tissue site” may also refer to areas of tissue that are not necessarily wounded or defective, but are instead areas in which it may be desired to add or promote the growth of additional tissue. For example, reduced pressure may be used in certain tissue areas to grow additional tissue that may be harvested and transplanted to another tissue location. In some embodiments, the tissue site 102 may be a wound that extends through the epidermis 112, through a dermis 118, and into subcutaneous tissue 120.

[0043] “Reduced pressure” generally refers to a pressure less than a local ambient pressure, such as the ambient pressure in a local environment external to a sealed therapeutic environment 124 provided by the medical drape 106. In many cases, the local ambient pressure may also be the atmospheric pressure in a patient’s vicinity. Alternatively, the pressure may be less than a hydrostatic pressure associated with tissue at the tissue site. Unless otherwise indicated, values of pressure stated herein are gauge pressures. Similarly, references to increases in reduced pressure typically refer to a decrease in absolute pressure, while decreases in reduced pressure typically refer to an increase in absolute pressure.

[0044] A reduced-pressure source, such as the reduced-pressure source 126, may be a reservoir of air at a reduced pressure, or may be a manual or electrically-powered device that can reduce the pressure in a sealed volume, such as a vacuum pump, a suction pump, a wall-suction port available at many healthcare facilities, or a micro-pump, for example. A reduced-pressure source may be housed within or used in conjunction with other components, such as sensors, processing units, alarm indicators, memory, databases, software, display devices, or operator interfaces that further facilitate reduced-pressure therapy. While the amount and nature of reduced pressure applied to a tissue site may vary according to therapeutic requirements, the pressure typically ranges between -5 mm Hg (-667 Pa) and -500 mm Hg (-66.7 kPa). Common therapeutic ranges are between -75 mm Hg (-9.9 kPa) and -300 mm Hg (-39.9 kPa).

[0045] A tissue interface, such as the manifold 122, can generally be adapted to contact a tissue site or other layers of a dressing, such as the medical drape 106. A tissue interface may be partially or fully in contact with a tissue site. If a tissue site is a wound, for example, a tissue interface may partially or completely fill the wound, or may be placed over the wound. A tissue interface may take many forms, and may be many sizes, shapes, or thicknesses depending on a variety of factors, such as the type of treatment being implemented or the nature and size of a tissue site. For example, the size and shape of a tissue interface may be adapted to the contours of deep and irregular shaped tissue sites.

[0046] Generally, a manifold, such as the manifold 122, for example, is a substance or structure adapted to distribute or remove fluids from a tissue site. A manifold may include flow channels or pathways that can distribute fluids provided to and removed from a tissue site. In one illustrative embodiment, the flow channels or pathways may be interconnected to improve distribution of fluids provided to or removed from a tissue site. For example, a manifold may be an open-cell foam, porous tissue collection, and other porous material such as gauze or felted mat that generally includes structural elements arranged to form flow channels. Liquids, gels, and other foams may also include or be cured to include flow channels.

[0047] In one illustrative embodiment, the manifold 122 may be a porous foam pad having interconnected cells adapted to distribute reduced pressure across a tissue site. The foam material may be either hydrophobic or hydrophilic. In one non-limiting example, the manifold 122 may be reticulated polyurethane foam such as GranuFoam[®] dressing available from Kinetic Concepts, Inc. of San Antonio, Texas.

[0048] In some embodiments, such as embodiments in which the manifold 122 may be made from a hydrophilic material, the manifold 122 may also wick fluid away from a tissue site while continuing to distribute reduced pressure to the tissue site. The wicking properties of the manifold 122 may draw fluid away from a tissue site by capillary flow or other wicking mechanisms. An example of a hydrophilic foam is a polyvinyl alcohol, open-cell foam such as V.A.C. WhiteFoam[®] dressing available from Kinetic Concepts, Inc. of San Antonio, Texas. Other hydrophilic foams may include those made from polyether. Other foams that may exhibit hydrophilic characteristics include hydrophobic foams that have been treated or coated to provide hydrophilicity.

[0049] A tissue interface may further promote granulation at a tissue site if pressure within a sealed therapeutic environment 124 is reduced. For example, any or all of the surfaces of the manifold 122 may have an uneven, coarse, or jagged profile that can induce microstrains and stresses at a tissue site if reduced pressure is applied through the manifold 122.

[0050] In some example embodiments, a tissue interface may be constructed from bioresorbable materials. Suitable bioresorbable materials may include, without limitation, a polymeric blend of polylactic acid (PLA) and polyglycolic acid (PGA). The polymeric blend may also include without limitation polycarbonates, polyfumarates, and capralactones. The tissue interface may further serve as a scaffold for new cell-growth, or a scaffold material

may be used in conjunction with the tissue interface to promote cell-growth. In general, a scaffold material may be a biocompatible or biodegradable substance or structure used to enhance or promote the growth of cells or formation of tissue, such as a three-dimensional porous structure that provides a template for cell growth. Illustrative examples of scaffold materials include calcium phosphate, collagen, PLA/PGA, coral hydroxy apatites, carbonates, or processed allograft materials.

[0051] The medical drape 106 is an example of a sealing member. A sealing member may be constructed from a material that can provide a fluid seal between two environments or components, such as between a therapeutic environment and a local external environment. The sealing member may be, for example, an impermeable or semi-permeable, elastomeric film or barrier that can provide a seal adequate to maintain a reduced pressure at a tissue site for a given reduced-pressure source. For semi-permeable materials, the permeability generally should be low enough that a desired reduced pressure may be maintained. An attachment device may be used to attach a sealing member to an attachment surface, such as undamaged epidermis, a gasket, or another sealing member. The attachment device may take many forms. For example, an attachment device may be a medically-acceptable, pressure-sensitive adhesive that extends about a periphery, a portion, or an entire sealing member. Other example embodiments of an attachment device may include a double-sided tape, paste, hydrocolloid, hydrogel, silicone gel, organogel, or an acrylic adhesive.

[0052] A "container" broadly includes a canister, pouch, bottle, vial, or other fluid collection apparatus. A container, for example, can be used to manage exudates and other fluids withdrawn from a tissue site. In many environments, a rigid container may be preferred or required for collecting, storing, and disposing of fluids. In other environments, fluids may be properly disposed of without rigid container storage, and a re-usable container could reduce waste and costs associated with reduced-pressure therapy.

[0053] A reduced-pressure interface 128 may be used to fluidly couple a reduced-pressure delivery conduit 130 to the sealed therapeutic environment 124. The reduced pressure developed by the reduced-pressure source 126 may be delivered through the reduced-pressure delivery conduit 130 to the reduced-pressure interface 128. In one illustrative embodiment, the reduced-pressure interface 128 may be a T.R.A.C.[®] Pad or Sensa T.R.A.C.[®] Pad available from KCI of San Antonio, Texas. The reduced-pressure interface 128 allows the reduced pressure to be delivered to the sealed therapeutic environment 124. In other exemplary embodiments, the reduced-pressure interface 128 may also be a conduit

inserted through the medical drape 106. The reduced pressure may also be generated by a device directly coupled to the medical drape 106, such as a micropump.

[0054] The provision of negative pressure therapy with negative pressure therapy systems, such as the system 100, is increasingly being performed with smaller therapy devices that use battery power rather than a connection to an electrical outlet. Use of battery power decreases the total power supply available to a therapy device. As a result, power drains that would be considered negligible in a device powered through an electrical outlet connection may significantly reduce the ability of the therapy device to provide therapy. A power drain refers to operation of the therapy device that requires use of electrical power, for example, operation of a pump to generate reduced pressure. Power drains may be caused by low-level dressing leaks, for example. A low-level dressing leak can drain power from a battery of a therapy device by repeatedly triggering operation of the therapy device to maintain the necessary reduced pressure at the tissue site. These power drains shorten the useful life of the therapy device before disposal of the therapy device, recharge of the battery, or battery replacement is required. Leak detection techniques may help to identify some leaks that may be then sealed by the user; however, low level leaks will challenge the most sensitive leak detection systems and may often go undetected.

[0055] Low level dressing leaks may occur between the medical drape and the epidermis surrounding a tissue site when the medical drape fails to completely seal to the epidermis. Medical drapes are a balance between the strength of the adhesive required to enable the medical drape to seal against leaks and the pain which may result when the medical drape is removed. A bonding adhesive may be better for sealing, but the adhesive strength would cause significantly more discomfort upon medical drape removal. In addition, removing a medical drape with a bonding adhesive may cause significant damage to patients having delicate or damaged skin.

[0056] A medical drape that has a sealing adhesive can fill gaps between the drape and the epidermis to limit leaks and can be easy to remove with low discomfort to the patient. Various sealing, gap-filling adhesives, such as silicone, hydrocolloids, and hydrogels, have been tried but each has drawbacks. For example, hydrogel adhesives are usually low tack and prone to swelling, creep, and mobility when used with fluid systems. In another example, silicone adhesives can fill gaps and seal, but are not breathable and may lose the necessary mechanical bonding strength as the silicone adhesives interact with moisture during use. To counter these problems, silicone adhesives often require additional materials

to secure the silicone adhesive to the patient. For example, a low leak medical drape may be formed from two adhesive layers: a thick sealing adhesive, perhaps in the shape of a gasket or ring, and a thinner bonding adhesive layer used to keep the sealing adhesive in place. The thinner bonding adhesive may be applied as medical drape strips, or combined with the thicker sealing adhesive as an outer border. Low-leak medical drapes constructed in this way can be more complex than a medical drape using a single adhesive, increasing the complexity of manipulation and operation.

[0057] A hybrid medical drape having a thick sealing layer that is perforated and laminated over an adhesive coated film can overcome some of these challenges. For example, a hybrid medical drape may include a film layer having a bonding adhesive applied directly to the film layer, and a sealing adhesive applied directly to the bonding adhesive. The sealing adhesive can be perforated to expose the bonding adhesive. When the medical drape is applied to a patient, the bonding adhesive can be pushed through the perforations of the sealing adhesive to secure the sealing adhesive to the patient. This laminated configuration may provide the benefits of the sealing adhesive and the bonding adhesive over the entire medical drape area. For example, the laminated configuration is able to seal typical low-level leaks, is conformable and of sufficient strength to ensure a seal, and mechanically affixes to the epidermis without secondary processes. The laminated configuration also requires minimal additional application care by the user and can be removable with minimal trauma to the patient.

[0058] However, construction of the laminated configuration requires additional assembly steps and an increase in materials that may significantly increase costs. In addition, as two layers of adhesive are applied to the film layer, the total thickness of the medical drape can significantly increase, reducing breathability of the medical drape. Still further, as two full layers of adhesive are applied, significantly more adhesive material is needed to construct the medical drape.

[0059] As disclosed herein, the system 100 can overcome these challenges and others by providing a hybrid medical drape with registered adhesives. In some embodiments, for example, the medical drape 106 may have two adhesives, a bonding adhesive and a sealing adhesive, each adhesive coupled to the medical drape 106 with minimal overlap.

[0060] Figure 2 is an exploded perspective view of the medical drape 106 illustrating additional details that may be associated with some embodiments. The medical drape 106 may include a flexible film 108 and an adhesive layer 110 adjacent to the flexible film 108.

The flexible film 108 may be a breathable drape, for example, and typically may have a high moisture-vapor-transfer-rate (MVTR). The flexible film 108 may be formed from a range of medically approved films ranging in thickness from about 15 microns (μm) to about 50 microns (μm). The flexible film 108 may comprise a suitable material or materials, such as the following: hydrophilic polyurethane (PU), cellulose, hydrophilic polyamides, polyvinyl alcohol, polyvinyl pyrrolidone, hydrophilic acrylics, hydrophilic silicone elastomers, and copolymers of these. As one specific, illustrative, non-limiting embodiment, the flexible film 108 may be formed from a breathable cast matt polyurethane film sold by Expopak Advanced Coatings of Wrexham, United Kingdom, under the name INSPIRE 2301.

[0061] The high MVTR of the flexible film 108 allows vapor to egress and inhibits liquids from exiting. In some embodiments, the MVTR of the flexible film 108 may be greater than or equal to $300\text{g}/\text{m}^2/24$ hours. In other embodiments, the MVTR of the flexible film 108 may be greater than or equal to $1000\text{g}/\text{m}^2/24$ hours. The illustrative INSPIRE 2301 film may have an MVTR (inverted cup technique) of $14400\text{g}/\text{m}^2/24$ hours and may be approximately 30 microns thick. In other embodiments, a drape having a low MVTR or that allows no vapor transfer might be used. The flexible film 108 can also function as a barrier to liquids and microorganisms.

[0062] Figure 3A is an exploded cross sectional view of the medical drape 106 illustrating additional details that may be associated with some embodiments. The flexible film 108 has a first side 134 and a second side 136. The adhesive layer 110 has a first side 140 and a second side 142. The first side 140 of the adhesive layer 110 may be coupled to the second side 136 of the flexible film 108. The adhesive layer 110 may be a medically-acceptable, pressure-sensitive adhesive, glue, bonding agent, or cement, for example. In some embodiments, two adhesives having different characteristics may be used to form the adhesive layer 110. For example, the adhesive layer 110 may include a first adhesive such as a bonding adhesive 132 and a second adhesive such as a sealing adhesive 138. In some embodiments, the placement of the bonding adhesive 132 and the sealing adhesive 138 may be coordinated so that the bonding adhesive 132 and the sealing adhesive 138 both couple to the second side 136 of the flexible film 108.

[0063] The bonding adhesive 132 may be a high bond strength acrylic adhesive, pattern rubber adhesive, high-tack silicone adhesive, or polyurethane, for example. In some embodiments, the bond strength of the bonding adhesive 132 may have a peel adhesion or resistance to being peeled from a stainless steel material between about $6\text{N}/25\text{mm}$ to about

10N/25mm on stainless steel substrate at 23° C at 50% relative humidity based on the American Society for Testing and Materials (“ASTM”) standard ASTM D3330. In a non-limiting illustrative example, the bonding adhesive 132 of the adhesive layer 110 comprises an acrylic adhesive with coating weight of 15 grams/m² (gsm) to 70 grams/m² (gsm). The bonding adhesive 132 may be about 30 microns to about 60 microns in thickness.

[0064] The sealing adhesive 138 may be an adhesive having a low to medium tackiness, for example, a silicone polymer, polyurethane, or an additional acrylic adhesive. In some embodiments, the bond strength of the sealing adhesive 138 may have a peel adhesion or resistance to being peeled from a stainless steel material between about 0.5N/25mm to about 1.5N/25mm on stainless steel substrate at 23° C at 50% relative humidity based on ASTM D3330. The sealing adhesive 138 may have a tackiness such that the sealing adhesive 138 may achieve the bond strength above after a contact time of less than 60 seconds. Tackiness may be considered a bond strength of an adhesive after a very low contact time between the adhesive and a substrate. In some embodiments, the sealing adhesive 138 may be about 100 microns to about 400 microns thick and have a tackiness that may be about 30% to about 50% of the tackiness of the bonding adhesive 132. The adhesive layer 110 may partially cover the second side 136 of the flexible film 108, leaving portions of the second side 136 of the flexible film 108 free of adhesive.

[0065] Figure 3B is a sectional view of the medical drape 106 illustrating additional details that may be associated with some embodiments. In some embodiments, the thickness of the bonding adhesive 132 may be less than the thickness of the sealing adhesive 138 so that the adhesive layer 110 may have a varying thickness. If the adhesive layer 110 is placed proximate to or in contact with the epidermis 112 of the patient 104, the second side 142 of the sealing adhesive 138 may be in contact with the epidermis 112 of the patient 104 to form sealing couplings 150. In some embodiments, the thickness of the bonding adhesive 132 may be less than the thickness of the sealing adhesive 138, forming a gap 139 between the bonding adhesive 132 and the epidermis 112.

[0066] Figure 3C is a sectional view of the medical drape 106 illustrating additional details that may be associated with some embodiments. If the medical drape 106 is in a desired location, pressure may be applied to the first side 134 of the flexible film 108. The pressure may cause the second side 142 of the bonding adhesive 132 to be pressed at least partially into contact with the epidermis 112 to form bonding couplings 152. The bonding couplings 152 provide secure, releasable mechanical fixation to the patient 104. The sealing

couplings 150 between the sealing adhesive 138 and the epidermis 112 may be sufficient to seal the flexible film 108 to the epidermis 112. The sealing couplings 150 may not be as mechanically strong as the bonding couplings 152 between the bonding adhesive 132 and the epidermis 112.

[0067] In operation, according to one illustrative embodiment of the medical drape 106 in the context of the system 100, the manifold 122 may be applied proximate to the tissue site 102. The medical drape 106 may then be disposed over the manifold 122 and the epidermis 112 to form the sealed therapeutic environment 124. In applying the medical drape 106, any release liners may be removed and the second side 142 of the adhesive layer 110 may be applied to the epidermis 112 and over the manifold 122. The tackiness of the sealing adhesive 138 may form sealing couplings 152 and hold the medical drape 106 initially in position. The tackiness of the sealing adhesive 138 may be such that if an adjustment or repositioning is desired, the medical drape 106 may be removed and reapplied or repositioned. If the medical drape 106 is in a desired position, the first side 134 of the flexible film 108 may be pressed, for example, with hand pressure. The pressure causes at least some portion of the bonding adhesive 132 to deform and contact the epidermis 112 to form the bonding couplings 152. The bonding couplings 152 may be a firm —although releasable—attachment. In some embodiments, the bonding couplings 152 may have a peel force against the epidermis 112 between about 0.5N/25mm to about 2N/25mm.

[0068] The pattern of the bonding adhesive 132 and the pattern of the sealing adhesive 138 may be registered. Registration of the bonding adhesive 132 and the sealing adhesive 138 generally refers to the alignment of the two adhesives relative to one another. In particular, registration of the bonding adhesive 132 and the sealing adhesive 138 may refer to the coordination of adhesive placement on the flexible film 108 to achieve a desired effect. For example, a certain percentage of overlap of one adhesive over the other adhesive, minimal overlap of one adhesive over the other adhesive so that the adhesives are offset from one another, or complete overlap of one adhesive over the other adhesive are all adhesive placements that may be considered registered. For example, the bonding adhesive 132 and the sealing adhesive 138 may be registered by being disposed on the second side 136 of the flexible film 108 so that the bonding adhesive 132 and the sealing adhesive 138 each substantially couple to the second side 136 of the flexible film 108. In addition, the bonding adhesive 132 and the sealing adhesive 138 of the example may be aligned relative to one another to have minimal overlap of one adhesive over the other adhesive. In another

example, the sealing adhesive 138 may be offset from the bonding adhesive 132, with both adhesives being coupled to the flexible film 108. Registering the bonding adhesive 132 and the sealing adhesive 138 provides for easier manufacturing and use of the medical drape 106. Registering of the bonding adhesive 132 and the sealing adhesive 138 may also enhance desired properties of the medical drape 106 as described in more detail below. Illustrative, but non-limiting, examples of the registration of the bonding adhesive 132 and the sealing adhesive 138 are described in more detail with respect to the following embodiments.

[0069] Figure 4A is a plan view of the second side 136 of the flexible film 108 illustrating additional details that may be associated with some embodiments. In some embodiments, the bonding adhesive 132 may be formed on or adhered to the flexible film 108 before the sealing adhesive 138. The bonding adhesive 132 may be applied to the second side 136 of the flexible film 108 to form one or more cells 715 of the bonding adhesive 132. In some embodiments, each cell 715 may be separated from adjacent cells 715 so that the cells 715 may generally be equally distributed about the second side 136 of the flexible film 108. The distribution of the cells 715 may leave portions 717 of the second side 136 of the flexible film 108 free of the bonding adhesive 132. The cells 715 may be distributed in a suitable pattern, and the distribution of the cells 715 may depend in part on the intended application of the medical drape 106. Other distributions of the cells 715 are contemplated. In some embodiments, each cell 715 may have a generally square shape, although other shapes, such as rectangular, circular, triangular, amorphous shaped cells, or the like are contemplated. Each cell 715 may have a thickness of about 30 microns to about 60 microns, although other thicknesses may be used.

[0070] Figure 4B is a plan view of the second side 136 of the flexible film 108 illustrating additional details that may be associated with some embodiments. In some embodiments, the sealing adhesive 138 may be formed on the flexible film 108 following formation of the cells 715 of the bonding adhesive 132. The sealing adhesive 138 may be distributed so that the portions 717 of the second side 136 of the flexible film 108 between each cell 715 may be covered by the sealing adhesive 138. In some embodiments, distribution of the sealing adhesive 138 on the portions 717 registers the sealing adhesive 138 with the cells 715 of the bonding adhesive 132. In some embodiments, both the sealing adhesive 138 and the bonding adhesive 132 may be applied substantially to the second side 136 of the flexible film 108 with minimal overlap of the sealing adhesive 138 and the bonding adhesive 132. In other embodiments, the sealing adhesive 138 may be disposed on

the second side 136 of the flexible film 108 prior to placement of the bonding adhesive 132 on the second side 136 of the flexible film 108. Some overlap between the bonding adhesive 132 and the sealing adhesive 138 may occur during manufacturing. The sealing adhesive 138 may have a thickness of about 100 microns to about 400 microns, although other thicknesses may be used. In some embodiments, the bonding adhesive 132 and the sealing adhesive 138 collectively cover substantially all of the second side 136 of the flexible film 108. In other embodiments, the bonding adhesive 132 and the sealing adhesive 138 may collectively cover a portion of the second side 136 of the flexible film 108 that may be less than the entirety of the second side 136.

[0071] Figure 5A is a plan views of the medical drape 106 illustrating additional details that may be associated with some embodiments. In some embodiments, the bonding adhesive 132 may first be deposited on the second side 136 of the flexible film 108. The bonding adhesive 132 may be distributed on the second side 136 of the flexible film 108 so that the bonding adhesive 132 forms a checkerboard pattern having cells 970 of the bonding adhesive 132 that may be offset from the cells 970 on adjacent rows. As shown, the cells 970 of the bonding adhesive 132 in this example embodiment may be disposed on the second side 136 of the flexible film 108 in three rows 971, 972, and 973. More or fewer rows may be used. In some embodiments, the cells 970 may be rectangular. In other embodiments, the cells 970 may be other shapes including, rectangular, square, circular, ovoid, triangular, amorphously shaped, or the like. Each cell 970 of each row may have a first dimension having a first orientation with respect to a first edge 937 of the flexible film 108 and a second dimension having a second orientation with respect to the first edge 937 of the flexible film 108. In some embodiments, each cell 970 may be rectangular in shape. The first dimension may be a length L, and the second dimension may be a width W. In some embodiments, the length L may be approximately twice the width W of each cell 970. In other embodiments, the cells 970 of each row may be differently shaped from the cells 970 of prior and successive rows.

[0072] In some embodiments, the length L of the cells 970 of the first row 971 may be aligned with a first edge 937 of the flexible film 108. The first row 971 may also be aligned with a second edge 941 of the flexible film 108 that may be opposite the first edge 937. In some embodiments, the cells 970 of the first row 971 may be disposed proximate to the first edge 937 of the flexible film 108. Each cell 970 of the first row 971 may be separated from adjacent cells 970 of the first row 971. The separation of adjacent cells 970

may provide a portion of the second side 136 of the flexible film 108 between each cell 970 that is free of the bonding adhesive 132. In some embodiments, the separation between each cell 970 of the first row 971 may be about the length L. A reference line 935 of the first row 971 may be aligned with a center of the width W of the cells 970 of the first row 971.

[0073] The second row 972 may be disposed adjacent to the first row 971 along the width of the flexible film 108. The second row 972 may be offset from the cells 970 of the first row 971 along the length of the flexible film 108. In some embodiments, the cells 970 of the second row 972 align with separation between the cells 970 of the first row 971, that is, between the cells 970 of the first row 971. In the illustrative embodiment of Figure 5A, a corner of a cell 970 of the first row 971 proximate to the second edge 941 is proximate to a corner of a cell 970 of the second row 972 that is proximate to the first edge 937. Each cell 970 of the second row 972 may be separated from adjacent cells 970 of the second row 972. In some embodiments, a portion of the second side 136 of the flexible film 108 may be substantially free of the bonding adhesive 132 between each cell 970 of the second row 972. In some embodiments, the separation between the cells 970 of the second row 972 may be about the length L of each cell 970.

[0074] The third row 973 may be disposed adjacent to the cells 970 of the second row 972 along the width of the flexible film 108. The cells 970 of the third row 973 may be offset from the cells 970 of the second row 972 and aligned with the cells 970 of the first row 971 along the length of the flexible film 108. As shown in the illustrative embodiment of Figure 5A, a corner of a cell 970 of the second row 972 proximate to the second edge 941 may be proximate to a corner of a cell 970 of the third row 973 that is proximate to the first edge 937. Each cell 970 of the third row 973 may be separated from adjacent cells 970 of the third row 973. In some embodiments, a portion of the second side 136 of the flexible film 108 may be free of the bonding adhesive 132 between each cell 970 of the third row 973. In some embodiments, the separation between each cell 970 of the third row 973 may be approximately equal to the length L of each cell 970 of the third row 973. The third row 973 may have a reference line 955 aligned with a center of the width W of the cells 970 of the third row 973. In some embodiments, the rows 971-973 may be evenly distributed across the width of the flexible film 108 between the first edge 937 and the second edge 941.

[0075] Figure 5B is a plan view of the second side 136 of the flexible film 108 illustrating additional details that may be associated with some embodiments. In some embodiments, the sealing adhesive 138 may be disposed on the second side 136 of the

flexible film 108 in strips. In some embodiments, there may be four strips of the sealing adhesive 138: a first strip 939, a second strip 943, a third strip 940, and a fourth strip 944. In some embodiments, each strip may have an oscillating shape, such as the illustrated sinusoidal wave or other periodically oscillating wave shape. In some embodiments, each strip may propagate parallel to the first edge 937 and the second edge 941. The first strip 939 and the second strip 943 may be oriented with the respect to the reference line 935. The maximum and minimum amplitudes of the first strip 939 and the second strip 943 may be determined relative to the reference line 935. The third strip 940 and the fourth strip 944 may be oriented with respect to the reference line 955. The maximum and minimum amplitudes of the third strip 940 and the fourth strip 944 may be determined relative to the reference line 955.

[0076] Figure 5C is a plan view of the second side 136 of the flexible film 108 illustrating additional details that may be associated with some embodiments. In some embodiments, a maximum amplitude of the first strip 939 and the second strip 943 may align with a center of the length L of the cells 970 of the first row 971. The first strip 939 and the second strip 943 may have a minimum amplitude proximate to reference line 935. The first strip 939 and the second strip 943 may have a frequency so that the minimum amplitude may align with a center of the length L of the cells 970 of the second row 972. In some embodiments, each of the first strip 939 and the second strip 943 may have an amplitude approximately equivalent to the width W of the cells 970 of the first row 971. In some embodiments, the first strip 939 and the second strip 943 of the sealing adhesive 138 may substantially enclose the cells 970 of the bonding adhesive 132 in the first row 971. Similarly, due to the offset of the cells 970 of the second row 972 from the cells 970 of the first row 971, the second strip 943 may also partially enclose the second row 972 of the bonding adhesive 132.

[0077] The third strip 940 and the fourth strip 944 of the sealing adhesive 138 may be deposited similarly. For example, the third strip 940 and the fourth strip 944 of the sealing adhesive 138 may be deposited proximate to the third row 973 of the bonding adhesive 132. In some embodiments, the third strip 940 and the fourth strip 944 may have a maximum amplitude from the reference line 955. The maximum amplitude of the third strip 940 and the fourth strip 944 may align with a center of the length L of the cells 970 of the third row 973. The third strip 940 and the fourth strip 944 may have a minimum amplitude proximate to reference line 955. The third strip 940 and the fourth strip 944 may have a frequency so

that the minimum amplitude may align with a center of the length L of the cells 970 of the second row 972. In some embodiments, the third strip 940 and the fourth strip 944 may have an amplitude approximately equivalent to the width W of the cells 970 of the third row 973. In some embodiments, the third strip 940 and the fourth strip 944 of the sealing adhesive 138 may enclose the cells 970 of the bonding adhesive 132 in the third row 973. Due to the offset of the cells 970 of the third row 973 with the cells 970 of the second row 972, the third strip 940 may partially enclose the second row 972 of the bonding adhesive 132.

[0078] The bonding adhesive 132 and the sealing adhesive 138 may cover only a portion of the second side 136 of the flexible film 108. In some embodiments, each cell 970 of the bonding adhesive 132 may be at least partially enclosed by the sealing adhesive 138. In some embodiments, the sealing adhesive 138 may be disposed on the second side 136 of the flexible film 108 prior to the disposition of the bonding adhesive 132 on the second side 136 of the flexible film 108. In some embodiments, the bonding adhesive 132 and the sealing adhesive 138 are registered. For example, portions of the second side 136 of the flexible film 108 covered by the bonding adhesive 132 may be different than the portions of the second side 136 of the flexible film 108 covered by the sealing adhesive 138. However, some overlap between the bonding adhesive 132 and the sealing adhesive 138 may occur.

[0079] Figures 6A-6C are plan views of the second side 136 of the flexible film 108 illustrating the bonding adhesive 132 and the sealing adhesive 138 disposed in another pattern that may be associated with other embodiments. In some embodiments, the bonding adhesive 132 may first be deposited on the second side 136 of the flexible film 108 as shown in Figure 6A. The flexible film 108 may have a reference line 961 aligned with a center of the width DW of the flexible film 108. The reference line 961 may be generally parallel to the first edge 937 and the second edge 941 of the flexible film 108. The bonding adhesive 132 may be deposited as a strip 960 of adhesive having an oscillating wave shape. For example, the strip 960 may have a sinusoidal wave shape, square-wave shape, or other periodically oscillating shape. In some embodiments, the strip 960 may have a peak-to-peak amplitude across the reference line 961 approximately equivalent to the width DW of the flexible film 108. The amplitude of the strip 960 may be other amplitudes so that the flexible film 108 may have multiple strips 960. For example, in other embodiments, the strip 960 may comprise two strips having a peak-to-peak amplitude equivalent to one-half the width of the flexible film 108, and the strips 960 may not cross the reference line 961.

[0080] A first strip 962 and a second strip 963 of sealing adhesive 138 having an oscillating wave shape may be deposited on the second side 136 of the flexible film 108. The oscillating wave shape of the first strip 962 and the second strip 963 may have a sine-wave shape, square-wave shape, or other periodically oscillating shape, for example. The first strip 962 and the second strip 963 may be disposed on opposite sides of the reference line 961 and propagate parallel to the first side 937 and the second side 941 of the flexible film 108. In some embodiments, the strip 960 may have a frequency greater than the frequency of the first strip 962 and the second strip 963 so that, for a given length of the flexible film 108, the bonding adhesive 132 of the strip 960 may provide more coverage of the second side 136 than the sealing adhesive 138 of the first strip 962 and the second strip 963. The amplitudes and the frequencies of the strip 960, the first strip 962, and the second strip 963 may vary as needed depending on the application of the particular medical drape 106.

[0081] As illustrated in Figure 5A-6C, there may be portions of the second side 136 of the flexible film 108 free of adhesives. Portions of the flexible film 108 that may be free of adhesive may expose more of the flexible film 108 directly to moisture. Increasing the direct exposure of the flexible film 108 to moisture may enhance vapor transmission, for example. Increasing vapor transmission may provide a corresponding increase in MVTR.

[0082] There may be a number of ways that the medical drape 106 may be manufactured. For example, a method of manufacturing a medical drape may include disposing a first adhesive on a side of the flexible film in a first pattern and disposing a second adhesive on the side of the flexible film in a second pattern so that the first adhesive and the second adhesive cover substantially different portions of the flexible film. The first pattern and the second pattern may be deposited by moving the flexible film past a rotary member so that the flexible film contacts a portion of an exterior of the rotary member while the flexible film moves relative to the rotary member. The rotary member may have openings formed in the exterior surface of the rotary member or an engraved portion in at least one of the first pattern and the second pattern. In some embodiments, one of the adhesives may be supplied to an interior of the rotary member, and the adhesive may be compressed through openings of the rotary member onto the flexible film. In other embodiments, one of the adhesives may be coated into the engraving on the exterior portion of the rotary member, and the adhesive may be transferred from the rotary member onto the flexible film. In still another embodiment, the adhesives may be deposited by extruding the adhesives onto the flexible film.

[0083] Figure 7A is a schematic diagram illustrating an example embodiment of an apparatus 700 for manufacturing the medical drape 106. The flexible film 108 may be provided on a conveyor assembly 701. The conveyor assembly 701 may be, for example, a belt conveyor, gravity conveyor, bucket conveyor, roller conveyor, chain conveyor, vibrating conveyor, or other suitable device, configured to transport the flexible film 108 through the apparatus 700. The conveyor assembly 701 may be one or more conveyor systems or a single conveyor system as schematically illustrated in Figure 7A. The conveyor assembly 701 may include additional components not illustrated or described herein that can support and operate the described components. The conveyor assembly 701 may include one or more rollers 705. The rollers 705 may be configured to cause translation of a belt or carrier, such as belt 703, and may be free-spinning or motorized. The flexible film 108 may be provided to the conveyor assembly 701. In some embodiments, the flexible film 108 may be provided to the conveyor assembly 701 in sheets that may appear continuous to the conveyor assembly 701. For example, the flexible film 108 may be provided in rolls that may be disposed onto the conveyor assembly 701. The conveyor assembly 701 may unroll the roll of the flexible film 108 as the conveyor assembly 701 moves a first end of the flexible film 108 through the process. The flexible film 108 may be disposed on the conveyor assembly 701 so that the second side 136 of the flexible film 108 may face away from the belt 703 of the conveyor assembly 701. In some embodiments, the flexible film 108 may move in response to movement of the belt 703 of the conveyor assembly 701.

[0084] As shown in Figure 7A, the conveyor assembly 701 may convey the flexible film 108 to a first screen assembly, such as screen assembly 707. The screen assembly 707 may include additional components not illustrated herein that support and operate the components described below. The screen assembly 707 may include a first rotary screen, such as rotary screen 709. The rotary screen 709 may be a cylinder having a polymeric or metal material mounted on an exterior portion of the cylinder so that the material forms a side surface of the rotary screen 709. The rotary screen 709 may have one or more openings 711 extending through the material of the rotary screen 709 to form a screen or mesh that allows an adhesive or other bonding material to flow through the rotary screen 709. The openings 711 may form a pattern so that the flow may be passively controlled. In some embodiments, the openings 711 may form a mesh having portions blocked to prevent flow at those locations. In one illustrative embodiment, the openings 711 in the rotary screen 709 correspond with a desired distribution of the bonding adhesive 132. Figure 7B illustrates a

portion of an exterior surface of the rotary screen 709. In some embodiments, the openings 711 may be one or more openings spaced axially parallel to an axis 710 of the rotary screen 709 and spaced around the circumference of the rotary screen 709. In a non-limiting illustrative embodiment, the openings 711 may be square shaped. An adhesive may be transferred through the square shape of the openings 711 to the flexible film 108, forming the one or more cells 715 distributed on the second side 136 of the flexible film 108 as illustrated in Figure 4A and 4B, for example.

[0085] Referring again to Figure 7A, the rotary screen assembly 707 may also include a first press, such as press 719. The press 719 may be disposed within an interior surface 721 of the rotary screen 709. The press 719 may be configured to compress a bonding material, such as the bonding adhesive 132, against the interior surface 721 of the rotary screen 709 and through the openings 711. In some embodiments, the press 719 may be a weighted object configured to roll along a bottom of the rotary screen 709. The press 719 may be a cylindrical weight positioned so that the side surface of the press 719 may be in contact with the interior surface 721. As the rotary screen 709 rotates, the press 719 may rotate and remain in contact with the interior surface 721. For example, the press 719 may be formed of a material having sufficient weight to remain in contact with the interior surface 721 during rotation or operation of the rotary screen 709. In other illustrative embodiments, the press 719 may be fixed on an axle to prevent relative linear motion between the rotary screen 709 and the press 719. The axle may be fixed or may float and be biased to maintain the press 719 in contact with the interior surface 721. In other embodiments, the press 719 may be motorized. In still other embodiments, the press 719 may be a blade or squeegee that does not rotate.

[0086] A bonding adhesive 720 may be supplied to the interior surface 721 of the rotary screen 709 by a suitable means, provided that the bonding adhesive 720 may be suitably viscous to flow through the rotary screen 709. In some embodiments, for example, the viscosity range of the bonding adhesive 132 may be between about 100mPa's to 10000mPa's. The bonding adhesive 132 may be pseudoplastic, that is, the viscosity of the bonding adhesive 132 may be proportional to the applied shear rate and shear thinning so that, at relatively high shear, the bonding adhesive 132 has a low viscosity. As the rotary screen 709 rotates in the direction indicated by the arrow 723 and the conveyor assembly 701 moves the flexible film 108 in the direction indicated by the arrow 725, the flexible film 108 may pass between the conveyor assembly 701 and a contact patch 727 of the rotary screen

709. The contact patch 727 may be that portion of the rotary screen 709 in contact with or adjacent to the belt 703 of the conveyor assembly 701 at a given moment during the manufacturing process. The press 719 may be disposed within the interior surface 721 of the rotary screen 709 adjacent to the contact patch 727.

[0087] As the rotary screen 709 rotates, the bonding adhesive 720 may be carried toward the press 719. Continued rotation of the rotary screen 709 causes the bonding adhesive 720 to engage the press 719, and the press 719 forces the bonding adhesive 720 through the openings 711 and onto the second side 136 of the flexible film 108. The press 719 remains adjacent to the contact patch 727 during operation of the screen assembly 707. The speed of rotation of the rotary screen 709 and the linear speed of the flexible film 108 through the conveyor assembly 701 may determine the amount and thickness of the bonding adhesive 720 deposited onto the second side 136 of the flexible film 108 as the cells 715 of the bonding adhesive 132. In some embodiments, the speed of the flexible film 108 through the conveyor assembly 701 and the speed of the rotary screen 709 may also be coordinated to control the distance between each cell 715 that may be deposited on the flexible film 108.

[0088] The conveyor assembly 701 may continue to move the flexible film 108 following passage of the flexible film 108 through the screen assembly 707. The conveyor assembly 701 may move the flexible film 108 and the cells 715 of the bonding adhesive 132 past a curing or drying assembly, such as curing assembly 729. The curing assembly 729 may be a suitable apparatus configured to cure or dry the cells 715 of the bonding adhesive 132 while the conveyor assembly 701 moves the flexible film 108 past the curing assembly 729. Other exemplary embodiments may not include the curing assembly 729. Following transfer of the bonding adhesive 132, the bonding adhesive 138 may increase in viscosity, through drying or curing whether assisted or unassisted, so that the bonding adhesive 132 may resist flow under the application conditions for the medical drape 106.

[0089] The conveyor assembly 701 may convey the flexible film 108 to a second screen assembly, such as screen assembly 731. The screen assembly 731 may include additional components not illustrated herein that support and operate the components described below. The screen assembly 731 may include a second rotary screen, such as rotary screen 733. The rotary screen 733 may be a cylinder having a polymeric or metal material mounted on an exterior portion of the cylinder so that the material forms a side surface of the rotary screen 733. The rotary screen 733 may have one or more openings 735 extending through the material of the rotary screen 733 to form a screen that allows an

adhesive or other bonding material to flow through the rotary screen 733. The openings 735 may form a pattern that permits flow through the rotary screen 733 to be passively controlled. In some embodiments, the openings 735 in the rotary screen 733 correspond with a desired distribution of the sealing adhesive 138. The openings 735 may be one or more openings axially separated along a length of the rotary screen 733 parallel to an axis 738 of the rotary screen 733 and separated around the circumference of the rotary screen 733. In other embodiments, the openings 735 may be a mesh permitting flow of a bonding material, through a substantial portion of the side surface of the rotary screen 733.

[0090] Figure 7C illustrates a portion of the exterior surface of the rotary screen 733. In some embodiments, the openings 735 may constitute a large portion of the exterior surface of the rotary screen 733. Barriers 734 may be disposed on the mesh forming the outer surface of the rotary screen 733. The barriers 734 may be disposed at certain locations around the circumference of the rotary screen 733, blocking communication through the side surface of the rotary screen 733. In some embodiments, the barriers 734 may be separated and axially parallel to an axis 738 of the rotary screen 733. The barriers 734 may also be separated around the circumference of the rotary screen 733. In some embodiments, the orientation of the barriers 734 on the side surface of the rotary screen 733 aligns the barriers 734 with the cells 715 of the bonding adhesive 132 previously applied to the second side 136 of the flexible film 108 by the first screen apparatus 707. The configuration of the barriers 734 permits application of the sealing adhesive 138 to the portions 717 of the second side 136 of the flexible film 108, but not to the cells 715 of the bonding adhesive 132 on the second side 136 of the flexible film 108 as shown in Figure 4B.

[0091] The screen assembly 731 may also include a second press, such as a press 739. The press 739 may be disposed within an interior of the rotary screen 733 and configured to compress an adhesive or bonding material, such as the sealing adhesive 138, against an interior surface 741 of the rotary screen 733. In some embodiments, the press 739 may be a weighted object configured to roll along a bottom of the rotary screen 733. In one non-limiting example, the press 739 may be a cylindrical weight positioned so that a side surface of the press 739 may be in contact with the interior surface 741. As the rotary screen 733 rotates, the press 739 may rotate and remain in contact with the interior surface 741. The press 739 may be formed of a suitable material having sufficient weight to remain in contact with the interior surface 741 during rotation or operation of the rotary screen 733. In other exemplary embodiments, the press 739 may be fixed on an axle to prevent relative linear

motion between the rotary screen 733 and the press 739. The axle may be fixed or may float and be biased to maintain the press 739 in contact with the interior surface 741. In other embodiments, the press 739 may be motorized. In still other embodiments, the press 739 may not rotate.

[0092] A sealing adhesive 740 may be supplied to the interior of the rotary screen 733 by a suitable means, provided that the sealing adhesive 740 has a suitable viscosity to allow flow of the sealing adhesive 740 through the openings 735. In some embodiments, for example, the viscosity range of the sealing adhesive 138 may be between about 100mPa's to 10000mPa's. The sealing adhesive 138 may be pseudoplastic, that is, the viscosity of the sealing adhesive 138 may be proportional to the applied shear rate and shear thinning so that, at relatively high shear, the sealing adhesive 138 has a low viscosity. As the rotary screen 733 rotates in the direction indicated by the arrow 743 and the conveyor assembly 701 moves in the direction indicated by the arrow 725, the flexible film 108 may pass between the conveyor assembly 701 and a contact patch 745 of the rotary screen 733. The contact patch 745 may be that portion of the rotary screen 733 in contact with or adjacent to the upper surface 703 of the conveyor assembly 701 at a given moment during the manufacturing process. The press 739 may be disposed within the interior 741 of the rotary screen 733 adjacent to the contact patch 745. As the rotary screen 733 rotates, the sealing adhesive 740 may be carried toward the press 739. As the sealing adhesive 740 engages the press 739, the press 739 may force the sealing adhesive 740 through the openings 735 and onto the second side 136 of the flexible film 108 as the sealing adhesive 138. The press 739 may remain adjacent to the contact patch 745 during operation of the screen assembly 731. If the openings 735 are a mesh having portions blocked to prevent flow, the sealing adhesive 740 may be deposited as the sealing adhesive 138. As shown in Figure 4B, the sealing adhesive 138 may register with the cells 715 to cover the portions 717 of the second side 136 of the flexible film 108, leaving the cells 715 of the bonding adhesive 132 exposed.

[0093] Continuing to refer to Figure 7A, the speed of rotation of the rotary screen 733 and the linear speed of the conveyor assembly 701 may be configured to control the amount of the sealing adhesive 720 deposited or transferred onto the second side 136 of the flexible film 108. In some embodiments, the speed of the conveyor assembly 701 and the speed of the rotary screen 739 may be coordinated so that the sealing adhesive 740 may be deposited between each cell 715 of the bonding adhesive to cover the portions 717.

[0094] The conveyor assembly 701 may continue to move the flexible film 108 following passage of the flexible film 108 through the screen assembly 731. The conveyor assembly 701 may move the flexible film 108 having the adhesive layer 110, formed of the bonding adhesive 132 and the sealing adhesive 138 disposed thereon, past a curing assembly, such as curing assembly 747. The curing assembly 747 may be a suitable apparatus configured to cure the sealing adhesive 138 while the conveyor assembly 701 moves the flexible film 108 past the curing assembly 747. Other exemplary embodiments do not include the curing assembly 747. Following transfer of the sealing adhesive 138, the sealing adhesive 138 may increase in viscosity, through drying or curing whether assisted or unassisted, so that the sealing adhesive 138 may resist flow under the application conditions for the medical drape 106. The rotary screen 709 and the rotary screen 733 may have a suitable formation of openings 711, 735 to apply a desired adhesive pattern on the second side 136 of the flexible film 108.

[0095] Figures 8A-8E are schematic diagrams illustrating another example apparatus 800 for manufacturing some embodiments of the medical drape 106. The flexible film 108 may be provided on a conveyor assembly 801. The conveyor assembly 801 may include one or more rollers 803 through which the flexible film 108 may be conveyed. Generally, the rollers 803 may suspend the flexible film 108 and may be motorized or otherwise powered so that the flexible film 108 may be carried through the conveyor assembly 801. The conveyor assembly 801 may be one or more conveyor systems or a single conveyor system as schematically illustrated in Figure 8A. The flexible film 108 may be provided to the conveyor assembly 801 in a suitable manner. In some embodiments, the flexible film 108 may be provided to the conveyor assembly 801 so that the conveyor assembly 801 receives the flexible film 108 in a continuous or nearly continuous sheet during operation of the conveyor assembly 801. For example, the flexible film 108 may be provided in rolls that may be disposed onto the conveyor assembly 801. The conveyor assembly 801 may unroll the rolls of the flexible film 108 as the conveyor assembly 801 moves a first end of the flexible film 108 through the apparatus 800.

[0096] The conveyor assembly 801 may convey the flexible film 108 to a first transfer assembly, such as a transfer assembly 805. The transfer assembly 805 may include additional components not illustrated herein to support and operate the schematically illustrated components. The transfer assembly 805 may include a first transfer cylinder, such as a transfer cylinder 807, a first well, such as a well 809, a first impression roll, such as an

impression roll 811, and a first blade, such as a blade 813, for example. The transfer cylinder 807 may be a cylinder having a side surface with an engraved pattern 814 formed in an exterior of the side surface of the cylinder. The well 809 may be a suitable container having an interior configured to house or store an adhesive or bonding material, such as the bonding adhesive 132. In some embodiments, the adhesive or bonding material may be stored in a liquid form. In other embodiments, the adhesive or bonding material may be stored in a gel form. In the illustrative embodiments, the bonding adhesive 132 may be housed in the well 809 in a suitably viscous form. The viscosity range of the bonding adhesive 132 may be between about 100mPa's to 10000mPa's. The bonding adhesive 132 may be pseudoplastic, that is, the viscosity of the bonding adhesive 132 may be proportional to the applied shear rate and shear thinning so that, at relatively high shear, the bonding adhesive 132 has a low viscosity. The transfer cylinder 807 and the well 809 may be disposed adjacent to each other so that a portion of the transfer cylinder 807 may be submerged in the bonding adhesive 132 during operation of the transfer assembly 805, submerging at least a portion of the engraved pattern 814 of the transfer cylinder 807 in the bonding adhesive 132.

[0097] In some embodiments, the well 809 may be mounted to a floor or other suitable support device and have an upper portion opposite the floor that may be open to the ambient environment. The transfer cylinder 807 may be mounted on an axle 815 so that a lower portion of the transfer cylinder 807 may be disposed within the interior of the well 809. The transfer cylinder 807 may be rotatable about an axle 815 passing through a center of the transfer cylinder 807. In some embodiments, the transfer cylinder 807 rotates about the axle 815 in the direction indicated by the arrow 817. As the transfer cylinder 807 rotates about the axle 815, the lower portion may be submerged in the bonding adhesive 132 housed within the well 809. While submerged, the bonding adhesive 132 may be drawn into the engraved pattern 814, filling the engraved pattern 814 with the bonding adhesive 132. In an embodiment, the bonding adhesive 132 may be drawn into the engraved pattern 814 by capillary action caused by the inter-molecular attractive forces between the bonding adhesive 132 and the engraved pattern 814. For example, adhesion forces between the bonding adhesive 132 and the solid surface of the engraved pattern 814 may pull the bonding adhesive 132 into the engraved pattern 814. As the submerged portion rotates out of the well 809, the submerged portion of the transfer cylinder 807 may rotate past the blade 813. The blade 813 may be a squeegee configured to exert a force on the surface of the transfer cylinder 807 and may be formed of a rubber based material or the like. The blade 813 may be in contact with

the exterior surface of the transfer cylinder 807 so that, as the transfer cylinder 807 rotates out of the well 809, excess amounts of the bonding adhesive 132, which may not be located in the engraved pattern 814, may be scraped or removed from the exterior surface of the transfer cylinder 807.

[0098] Continued rotation of the transfer cylinder 807 brings the exterior surface of the transfer cylinder 807 having the engraved pattern 814 full of the bonding adhesive 132 proximate to the impression roll 811. The impression roll 811 may be disposed adjacent to the transfer cylinder 807 so that a sheet or film, such as the flexible film 108, placed between the exterior surface of the transfer cylinder 807 and an exterior surface of the impression roll 811 may be compressed between them. The impression roll 811 may be configured to rotate on an axis 819 in the direction indicated by the arrow 821 so that the flexible film 108 may be passed through the transfer assembly 805. As the flexible film 108 passes between the exterior surfaces of the transfer cylinder 807 and the impression roll 811, the second side 136 of the flexible film 108 may be pressed against the exterior of the side surface of the transfer cylinder 807 by the impression roll 811 at a location 823. The compression causes the bonding adhesive 132 drawn into the engraved pattern on the exterior of the side surface of the transfer cylinder 807 to be transferred onto the second side 136 of the flexible film 108 as a portion of the adhesive layer 110.

[0099] The conveyor assembly 801 may continue to move the flexible film 108 following passage of the flexible film 108 through the transfer assembly 805. For example, the conveyor assembly 801 may move the flexible film 108, having the bonding adhesive 132 deposited by the transfer assembly 805 thereon, past a curing or drying assembly, such as the curing assembly 825. The curing assembly 825 may be a suitable apparatus configured to cure or dry the bonding adhesive 132 while the conveyor assembly 801 moves the flexible film 108 past the curing assembly 825. Following transfer of the bonding adhesive 132, the bonding adhesive 132 may increase in viscosity, through drying or curing and whether assisted or unassisted, so that the bonding adhesive 132 may resist flow under the application conditions for the medical drape 106. In some embodiments, the flexible film 108 may be configured to pass through another transfer assembly (not shown) to deposit another layer of the bonding adhesive 132 onto the second side 136 so that the bonding adhesive 132 may have a suitable thickness. In these embodiments, the conveyor assembly 801 may be configured to transport the flexible film 108 having the bonding adhesive 132 through another transfer assembly, to operate in reverse to re-feed the flexible film 108 through the

transfer assembly 805, or the flexible film 108 may be removed from the conveyor assembly 801 and passed through the transfer assembly 805 again to apply another layer of the bonding adhesive 132.

[00100] Once the bonding adhesive 132 of the adhesive layer 110 may be of a suitable thickness, the conveyor assembly 801 may convey the flexible film 108 and the bonding adhesive 132 to a second transfer assembly, such as a transfer assembly 827. The transfer assembly 827 may include a second transfer cylinder, such as transfer cylinder 829, a second well, such as a well 831, a second impression roll, such as an impression roll 833, and a second blade, such as a blade 835. The transfer cylinder 829 may be a cylinder having a side surface with an engraved pattern 830 formed in an exterior of the side surface of the cylinder. The second well 831 may be a suitable container having an interior configured to house or store the sealing adhesive 138. In some embodiments, the adhesive or bonding material may be stored in a liquid form. In other embodiments, the adhesive or bonding material may be stored in a gel form. In the illustrative embodiments, the sealing adhesive 138 may be housed in the second well 831 in a suitably viscous form. In an embodiment, the viscosity range of the sealing adhesive 138 may be between about 100mPa's to 10000mPa's. The sealing adhesive 138 may be pseudoplastic, that is, the viscosity of the sealing adhesive 138 may be proportional to the applied shear rate and shear thinning so that, at relatively high shear, the sealing adhesive 138 has a low viscosity. The transfer cylinder 829 and the second well 831 may be disposed adjacent to each other so that a lower portion of the transfer cylinder 829 may be submerged in the sealing adhesive 138 during operation of the transfer assembly 827, submerging at least a portion of the engraved pattern 830 of the transfer cylinder 829 in the sealing adhesive 138.

[00101] In some embodiments, the second well 831 may be mounted to a floor or other suitable support device and have an upper portion opposite the floor that may be open to the ambient environment. The transfer cylinder 829 may be mounted on an axle 837 so that a lower portion of the transfer cylinder 829 may be disposed within the interior of the second well 831. The transfer cylinder 829 may be rotatable about an axle 837 passing through a center of the transfer cylinder 829. In some embodiments, the transfer cylinder 829 rotates about the axle 837 in the direction indicated by the arrow 839. As the transfer cylinder 829 rotates about the axle 837, a portion of the exterior of the side surface of the transfer cylinder 829 may be submerged in the sealing adhesive 138 housed within the second well 831. While submerged, the sealing adhesive 138 may be drawn into the engraved

pattern 830, filling the engraved pattern 830 with the sealing adhesive 138. In some embodiments, the sealing adhesive 138 may be drawn into the engraved pattern 830 by capillary action due to the inter-molecular attractive forces between the sealing adhesive 138 and the engraved pattern 830. As the submerged portion rotates out of the second well 831, the submerged portion of the transfer cylinder 829 may rotate past the blade 835. The blade 835 may be a squeegee configured to exert a force on the surface of the transfer cylinder 829 and may be formed of a rubber based material or the like. The blade 835 may be in contact with the exterior side surface so that, as the transfer cylinder 829 rotates out of the second well 831, excess amounts of the sealing adhesive 138 not located in the engraved pattern 830 may be scraped or removed from the exterior surface of the transfer cylinder 829.

[00102] Continued rotation of the transfer cylinder 829 brings the exterior of the side surface of the transfer cylinder 829 having the engraved pattern 830 full of the sealing adhesive 138 proximate to the impression roll 833. The impression roll 833 may be disposed adjacent to the transfer cylinder 829 so that a sheet or film, such as the flexible film 108, placed between the exterior side surface of the transfer cylinder 829 and an exterior surface of the impression roll 833 may be compressed between them. The impression roll 833 may be configured to rotate on an axle 841 in the direction indicated by the arrow 843 so that the flexible film 108 may be passed through the transfer assembly 827. As the flexible film 108 passes between the exterior surfaces of the transfer cylinder 829 and the impression roll 833, the second side 136 of the flexible film 108 may be pressed against the exterior of the side surface of the transfer cylinder 829 by the impression roll 833 at a location 834. The compression causes the sealing adhesive 138 drawn into the engraved pattern on the exterior surface of the transfer cylinder 829 to be transferred onto the second side 136 of the flexible film 108 as the sealing adhesive 138 portion of the adhesive layer 110.

[00103] The conveyor assembly 801 continues to move the flexible film 108 following passage of the flexible film 108 through the transfer assembly 827. The conveyor assembly 801 may move the flexible film 108, having the adhesive layer 110 printed thereon, past a curing or drying assembly, such as curing assembly 845. The curing assembly 845 may be a suitable apparatus configured to cure or dry the sealing adhesive 138 while the conveyor assembly 801 moves the flexible film 108 past the curing assembly 845. Following transfer of the sealing adhesive 138, the sealing adhesive 138 may increase in viscosity, through drying or curing and whether assisted or unassisted, so that the sealing adhesive 138 may resist flow under the application conditions for the medical drape 106. In some

embodiments, the flexible film 108 may be configured to pass through another transfer assembly (not shown) to deposit another layer of the sealing adhesive 138 so that the sealing adhesive 138 may have a suitable thickness. In these embodiments, the conveyor assembly 801 may be configured to transport the flexible film 108 having the sealing adhesive 138 through another transfer assembly, to operate in reverse to re-feed the flexible film 108 through the transfer assembly 827, or the flexible film 108 may be removed from the conveyor assembly 801 and passed through the transfer assembly 827 again to apply another layer of the sealing adhesive 138.

[00104] Figures 8B-8E are schematic diagrams illustrating additional details that may be associated with example embodiments of the transfer cylinder 807 and the second transfer cylinder 827. For example, as shown in Figure 8B, the engraved pattern 814 may comprise cells aligned on the surface of the transfer cylinder 807 to deposit the cells 715 of the bonding adhesive 132 of the adhesive layer 110 illustrated in Figure 4A. Similarly, as shown in Figure 8D, the engraved pattern 814 may comprise cells aligned on the surface of the transfer cylinder 807 to deposit the cells 970 of the bonding adhesive 132 of the adhesive layer 110 illustrated in Figure 5A. In some embodiments, the speed of the conveyor assembly 801 and the speed of the transfer cylinder 807 may be coordinated to ensure desired deposition of the bonding adhesive 132. As shown in Figure 8C, the engraved pattern 830 may encompass a substantial portion of the exterior surface of the transfer cylinder 829. Unengraved portions of the exterior surface of the transfer cylinder 829 may form plateaus 828 having a size and shaped substantially equivalent to the cells 715 of the bonding adhesive 132. The plateaus 828 may be aligned on the surface of the transfer cylinder 829 to contact the cells 715 of the bonding adhesive 132 to deposit the sealing adhesive 138 onto portions 717 of the second side 136 of the flexible film 108 as illustrated in Figure 4B. The plateaus 828 may prevent or limit overlap of the bonding adhesive 132 by the sealing adhesive 138. Similarly, as shown in Figure 8E, the engraved pattern 830 may comprise strips aligned on the surface of the transfer cylinder 829 to deposit the first strip 939 and the second strip 943 of the sealing adhesive 138 illustrated in Figure 5B. In some embodiments, the speed of the conveyor assembly 801 and the speed of the transfer cylinder 829 may be coordinated to ensure desired deposition of the sealing adhesive 138 of the adhesive layer 110.

[00105] Figures 9A and 9B are schematic diagrams of an extrusion apparatus 900 for the manufacturing of the medical drape 106. The flexible film 108 may be provided on a conveyor assembly 901. The conveyor assembly 901 may include one or more rollers

903 on which the flexible film 108 may be disposed. Generally, the rollers 903 may support the flexible film 108 and may be motorized or otherwise powered so that the flexible film 108 may be transported on the conveyor assembly 901. The conveyor assembly 901 may be a conveyor belt, gravity conveyor, bucket conveyor, roller conveyor, chain conveyor, vibrating conveyor, or other device, configured to transport the medical drape 106 through the extrusion apparatus 900. The conveyor assembly 901 may be one or more conveyor systems or a single conveyor system as schematically illustrated in Figure 9A. The flexible film 108 may be provided to the conveyor assembly 901 in a suitable manner. In some embodiments, the flexible film 108 may be provided to the conveyor assembly 901 in sheets that appear continuous to the conveyor assembly 901 during operation of the conveyor assembly 901. For example, the flexible film 108 may be provided in rolls that may be disposed onto the conveyor assembly 901 and unrolled by the conveyor assembly 901 as the conveyor assembly 901 moves a first end of the flexible film 108 through the extrusion apparatus 900. The flexible film 108 may be disposed on the conveyor assembly 901 so that the first side 134 of the flexible film 108 may be adjacent to an upper surface 905 of a belt of the conveyor assembly 901.

[00106] The conveyor assembly 901 may convey the flexible film 108 through an extrusion assembly 907. The extrusion assembly 907 can include one or more bonding adhesive extruders, such as bonding adhesive extruder 909, and one or more sealing adhesive extruders, such as sealing adhesive extruders 911. The bonding adhesive extruder 909 may be coupled to a bonding adhesive supply 913 for the supply of the bonding adhesive 132 to the bonding adhesive extruder 909. Similarly, the sealing adhesive extruders 911 may be coupled to a sealing adhesive supply 915 for the supply of sealing adhesive 138 to the sealing adhesive extruders 911. The extrusion assembly 907 may also include a control system 917 communicatively coupled to the bonding adhesive extruder 909, the sealing adhesive extruders 911, the bonding adhesive supply 913, and the sealing adhesive supply 915 to operate the extrusion assembly 907 as disclosed herein.

[00107] The control system 917 may include programmable logic controllers, data processing systems, or the like, configured to receive input from the above listed devices and communicate with those same devices for operation thereof. A data processing system suitable for storing and/or executing program code may include at least one processor coupled directly or indirectly to memory elements through a system bus. The memory elements can include local memory employed during actual execution of the program code,

bulk storage, and cache memories which provide temporary storage of at least some program code in order to reduce the number of times code may be retrieved from bulk storage during execution. The bonding adhesive extruder 909 and the sealing adhesive extruders 911 may be coupled to respective motorized controllers and operable for motion relative to an initial position as disclosed herein. The motorized controllers may be a suitable device configured to receive operative signals or instructions from the control system 917.

[00108] The control system 917 may include discreet input/output devices that may be suitable devices such as pneumatic sensors, temperature sensors, or the like configured to communicate signals to the control system 917. Input/output or I/O devices (including but not limited to keyboards, displays, pointing devices, etc.) can be coupled to the system either directly or through intervening I/O controllers. Network adapters, such as a modem or ethernet card, may also be coupled to the control system 917 to enable the control system 917 to become coupled to other data processing systems or remote printers or storage devices through intervening private or public networks.

[00109] Each bonding adhesive extruder 909 may be disposed proximate to the upper surface 905 of the conveyor assembly 901. Each bonding adhesive extruder 909 may include a valve and a die configured to extrude an amount of bonding adhesive 132 at a pre-defined interval for a pre-defined duration to deposit the bonding adhesive 132 on the second side 136 of the flexible film 108. Figure 9B is a schematic diagram representing a portion of a cross section of the extrusion apparatus 900 taken along line 9B—9B of Figure 9A. The view of Figure 9B is taken at a moment in time (t) during operation of the extrusion apparatus 900 where a portion of the bonding adhesive 132 and the sealing adhesive 138 may have been deposited onto the flexible film 108 as described in more detail below. Three bonding adhesive extruders 909 are illustrated in the exemplary embodiments of Figure 9B, including a first bonding adhesive extruder 909A, a second bonding adhesive extruder 909B, and a third bonding adhesive extruder 909C. Each bonding adhesive extruder 909 may be arranged relative to an adjacent bonding adhesive extruder 909 so that the respective nozzles may be aligned across a width of the flexible film 108. In some embodiments, the first bonding adhesive extruder 909A, the second bonding adhesive extruder 909B, and the third bonding adhesive extruder 909C may coat the width of the flexible film 108 with the bonding adhesive 132 when the first bonding adhesive extruder 909A, the second bonding adhesive extruder 909B, and the third bonding adhesive extruder 909C may be actuated substantially simultaneously. For example, if each of the first bonding adhesive extruder 909A, the second

bonding adhesive extruder 909B, and the third bonding adhesive extruder 909C actuated substantially simultaneously, the bonding adhesive 132 would substantially cover the second side 136 of the flexible film 108. In some embodiments, the valves of the first bonding adhesive extruder 909A, the second bonding adhesive extruder 909B, and the third bonding adhesive extruder 909C may be alternately actuated by the control system 917 so that a checkerboard pattern may be deposited on the second side 136 of the flexible film 108 as illustrated in Figure 5A.

[00110] Continuing to refer to Figure 9B, the adhesive layer 110 may be deposited in the following illustrative manner. As the conveyor assembly 901 moves the flexible film 108 past the first bonding adhesive extruder 909A, the second bonding adhesive extruder 909B, and the third bonding adhesive extruder 909C, the control system 917 may actuate the first bonding adhesive extruder 909A and the third bonding adhesive extruder 909C to extrude the bonding adhesive 132 through the respective nozzles for a duration of about three seconds. Following the three second extrusion, the control system 917 may then stop the extrusion of bonding adhesive 132 through the first bonding adhesive extruder 909A and the third bonding adhesive extruder 909C. The control system 917 may then actuate the second bonding adhesive extruder 909B to deposit the bonding adhesive 132 for a duration of about three seconds. The apparatus may then alternately actuate the first bonding adhesive extruder 909A and the third bonding adhesive extruder 909C, and the second bonding adhesive extruder 909B. In this manner, the bonding adhesive 132 may be deposited as shown in Figure 5A to form the first row 971, the second row 972, and the third row 973. The first bonding adhesive extruder 909A, the second bonding adhesive extruder 909B, and the third bonding adhesive extruder 909C may each be operated independently for varying durations to form a desired pattern of the adhesive layer 110 on the second side 136 of the flexible film 108. In other embodiments, more or fewer bonding adhesive extruders 909 may be used and actuated in a suitable manner for a suitable duration to deposit the desired pattern on the second side 136 of the flexible film 108. The extrusion duration may be shorter or longer than three seconds as desired.

[00111] Continuing to refer to Figures 9A and 9B, the sealing adhesive 138 may be applied in the following illustrative manner. Two pairs of sealing adhesive extruders 911 are shown in Figure 9B. The first pair of sealing adhesive extruders 911 includes a first sealing adhesive extruder 911A and a second sealing adhesive extruder 911B that may be positioned relative to the reference line 935. In some embodiments, the first sealing adhesive

extruder 911A may be configured to move parallel to the width of the flexible film 108 a preset distance from the reference line 935 so that the first sealing adhesive extruder 911A may oscillate between the reference line 935 and the first edge 937 of the flexible film 108. The oscillation may occur in a sinusoidal manner so that, if the flexible film 108 is conveyed past the first sealing adhesive extruder 911A, the first strip 939 of the sealing adhesive 138 may be deposited on the second side 136 of the flexible film 108. Similarly, the second sealing adhesive extruder 911B may be configured to move parallel to the width of the flexible film 108 a preset distance from the reference line 935 so that the second sealing adhesive extruder 911B may oscillate between the reference line 935 and the second edge 941 of the flexible film 108. The oscillation may occur in a sinusoidal manner so that, if the flexible film 108 is carried past the second sealing adhesive extruder 911B, the second strip 943 of the sealing adhesive 138 having sinusoidal wave form may be deposited on the second side 136 of the flexible film 108.

[00112] The second pair of sealing adhesive extruders 911 includes a third sealing adhesive extruder 911C and a fourth sealing adhesive extruder 911D that may be positioned relative to the reference line 955. In some embodiments, the third sealing adhesive extruder 911C may be configured to move parallel to the width of the flexible film 108 a preset distance from the reference line 955 so that the third sealing adhesive extruder 911C may oscillate between the reference line 955 and the first edge 937 of the flexible film 108. For example, the oscillation may occur in a sinusoidal manner so that, if the flexible film 108 is carried past the third sealing adhesive extruder 911C, the strip 940 of the sealing adhesive 138 having a sinusoidal wave form may be deposited on the second side 136 of the flexible film 108. Similarly, the fourth sealing adhesive extruder 911D may be configured to move parallel to the width of the flexible film 108 a preset distance from the reference line 955 so that the fourth sealing adhesive extruder 911D may oscillate between the reference line 955 and the second edge 941 of the flexible film 108. The oscillation may occur in a sinusoidal manner so that, if the flexible film 108 is carried past the fourth sealing adhesive extruder 911D, the strip 944 of the sealing adhesive 138 having a sine-wave shape may be deposited on the second side 136 of the flexible film 108. The control system 917 may control the speed of oscillation of the pairs of sealing adhesive extruders 911. In some embodiments, the pairs of sealing adhesive extruders 911 may be actuated by the control system 917 to deposit the first adhesive strip 939, the second adhesive strip 943, the third

adhesive strip 940, and the fourth adhesive strip 944 on the second side 136 of the flexible film 108 as illustrated in Figure 5B.

[00113] Figures 10A and 10B are schematic diagrams of other embodiments of an extrusion apparatus 1000 configured to deposit the adhesive layer 110 of the illustrative medical drape 106 of Figures 6A-6C. The extrusion apparatus 1000 may generally include the equipment shown and described with respect to Figures 9A and 9B, modified as described below. The reference labels of the components of Figures 9A and 9B that may be substantially similar in Figures 10A and 10B and analogous components have been indicated by indexing the reference numerals by 100. For example, the extrusion apparatus 1000 may include a conveyor assembly 1001 having rollers 1003, and a belt 1005; and an extrusion assembly 1007 having a bonding adhesive supply 1013, a sealing adhesive supply 1015, and a control system 1017. Each component of the conveyor assembly 1001 and the extrusion assembly 1007 may be substantially similar to the components of the conveyor assembly 901 and the extrusion assembly 907 described above with respect to Figure 9A. Figure 10B is a schematic diagram, representative of a portion of a cross-section of the extrusion apparatus 1000 taken along line 10B—10B of Figure 10A. The view of Figure 10B is taken at a moment in time (t) during operation of the extrusion apparatus 1000 where a portion of the bonding adhesive 132 and the sealing adhesive 138 may have been deposited onto the flexible film 108. The sealing adhesive 138 may be deposited on the second side 136 of the flexible film 108 in a manner similar to that described with respect to Figures 9A and 9B, to deposit the first strip 962 and the second strip 963 of Figure 10B. The bonding adhesive extruder 1009 may be an oscillating extruder 1009. The oscillating extruder 1009 may oscillate about a reference line 961. The oscillation may occur in a sinusoidal manner so that, if the flexible film 108 is carried past the oscillating extruder 1009, a strip 960 of the bonding adhesive 132 having an oscillating wave form may be deposited on the second side 136 of the flexible film 108. In some embodiments, the period of oscillation for the oscillating extruder 1009 may be shorter than the period of oscillation for the first sealing adhesive extruder 1011A and the second sealing adhesive extruder 1011B of the first pair of sealing adhesive extruders 1011.

[00114] The manufacturing apparatuses described above with respect to specific embodiments of the medical drape 106 may be used to manufacture the embodiments of Figures 4A-6C, as well as variations thereof. In some embodiments, the rheology of the adhesives may be modified in a suitable manner to reduce the amount of flow between the

process of deposition onto the flexible film 108 by the screen depositing, transfer, or extrusion processes and curing or drying to prevent adhesive migration onto undesired areas of the flexible film 108. In still other embodiments, the flexible film 108 may be rotated or inverted repeatedly during the drying or curing process to limit adhesive migration on the flexible film 108.

[00115] In still other embodiments, the adhesives may be mixed with blowing or expanding agents, for example organic and inorganic low temperature boiling point liquids. The blowing or expanding agents allow for the adhesives to expand under the application of heat or light to increase the thickness of the adhesive following deposition by one of the above described processes. The blowing or expanding agents may reduce the amount of adhesive needed and decrease the cost of production and the cost of the resulting medical drape 106. In some embodiments, the application of heat or light may be delayed until application of the medical drape 106 to the epidermis 112 of the patient 104 so that the contact area with the patient's epidermis 112 may increase as the bonding adhesive 132 and the sealing adhesive 138 warm by contact with the patient's epidermis 112. The application of light or heat following application of the medical drape 106 to the epidermis 112 can provide a better seal for some embodiments of the medical drape 106 to the epidermis 112.

[00116] Using the above described apparatuses to manufacture patterned adhesive layers onto a drape can provide numerous advantages. For example, the amount of overlap between adhesive layers can be decreased and allow greater control of the application of the adhesive to the drape. The amount of adhesive needed to achieve the desired results can be decreased, providing a cost savings over prior art manufacturing methods. A hybrid medical drape 106 having two adhesive types may be produced that allows for an increased evaporation efficiency. Areas of the flexible film 108 uncovered by either the bonding adhesive 132 or the sealing adhesive 138 can also allow for high fluid diffusion and evaporation over coated regions. High fluid diffusion and evaporation can increase the ability of the medical drape 106 to manage fluid balance with healthy skin. High fluid diffusion and evaporation can also increase the ability of the medical drape 106 to evaporate fluid from underlying structures, such as the manifold 122. When combined with system 100 of Figure 1, the medical drape 106 may increase the diffusion efficiency of the system 100. In addition, use of a broader range of combinations of different adhesives may be obtained. Still further, the process of manufacturing the medical drape 106 may be simplified, further decreasing the cost of production of the medical drape 106.

[00117] Although certain structures and their advantages have been disclosed in the context of certain illustrative, non-limiting embodiments, it should be understood that various changes, substitutions, permutations, and alterations can be made without departing from the scope of the appended claims. It will be appreciated that features that may be described in connection to one embodiment may also be applicable to other embodiments. It will also be understood that the benefits and advantages described above may relate to one embodiment or may relate to several embodiments. It will further be understood that reference to “an” item refers to one or more of those items.

[00118] The steps of the methods described herein may be carried out in a suitable order, or simultaneously where appropriate.

[00119] Where appropriate, aspects of the embodiments described above may be combined with aspects of the other embodiments described to form further examples having comparable or different properties and addressing the same or different problems.

[00120] It will be understood that the embodiments described herein are given by way of example only and that various modifications may be made by those skilled in the art. The above specification, examples and data provide a complete description of the structure and use of exemplary embodiments. Although various embodiments have been described above with a certain degree of particularity, or with reference to one or more individual illustrations, those skilled in the art could make numerous alterations to the example embodiments without departing from the scope of the claims.

CLAIMS

We claim:

1. A medical drape comprising:
 - a flexible film; and
 - a first adhesive disposed on a first portion of a side of the flexible film in a first pattern, and
 - a second adhesive disposed on a second portion of the side of the flexible film in a second pattern, the second pattern registered with the first pattern so that the first portion and the second portion cover substantially different portions of the side of the flexible film, wherein the second adhesive has a thickness that is greater than a thickness of the first adhesive.
2. The medical drape of claim 1, wherein the second adhesive has a tackiness less than a tackiness of the first adhesive.
3. The medical drape according to claim 1 or claim 2, wherein the first adhesive has a thickness between about 30 microns and about 65 microns, and the second adhesive has a thickness between about 100 microns and about 400 microns.
4. The medical drape according to any one of claims 1 to 3, wherein the first portion and the second portion cover less than the side of the flexible film.
5. The medical drape according to any one of claims 1 to 4, wherein:
 - the first pattern comprises a plurality of cells; and
 - the second pattern substantially covers the flexible film between the cells of the first pattern.
6. The medical drape of claim 5, wherein the cells are equidistantly separated on the flexible film.

7. The medical drape according to any one of claims 1 to 4, wherein the second pattern comprises one or more periodic wave-shaped strips of the second adhesive that propagate parallel to an edge of the flexible film.
8. The medical drape according to any one of claims 1 to 4 and 7, wherein the first pattern comprises a strip of adhesive having a periodic wave-shape that propagates parallel to an edge of the flexible film.
9. The medical drape of claim 8, wherein the strip of adhesive has a peak-to-peak amplitude substantially equivalent to a width of the flexible film.
10. The medical drape according to any one of claims 1 to 9, wherein the flexible film comprises a polyurethane film.
11. The medical drape according to any one of claims 1 to 10, wherein the flexible film has a moisture vapor transfer rate between about 300 g/m²/24 hours to about 14,400 g/m²/24 hours.
12. The medical drape of claim 11, wherein the flexible film has a moisture vapor transfer rate of about 1000 g/m²/24 hours.
13. The medical drape according to any one of claims 1 to 12, wherein the first adhesive is an acrylic adhesive, and the second adhesive is a silicone adhesive.

14. A system for treating a tissue site with reduced pressure, the system comprising:
 - a manifold for distributing reduced pressure proximate to a tissue site;
 - a reduced-pressure source fluidly coupled to the manifold;
 - a drape; and
 - a first adhesive and a second adhesive coupled to the drape, the second adhesive registered with the first adhesive so that the first adhesive and the second adhesive cover substantially different portions of the drape, wherein the second adhesive has a thickness greater than a thickness of the first adhesive.
15. The system of claim 14, wherein the first adhesive is configured to bond the drape proximate to the tissue site, and the second adhesive is configured to seal the drape proximate to the tissue site to form a sealed space that contains the manifold.
16. The system according to claim 14 or claim 15, wherein the second adhesive has a tackiness less than a tackiness of the first adhesive.
17. The system according to any one of claims 14 to 16, wherein the drape comprises a flexible film, and the first adhesive and the second adhesive substantially cover a side of the flexible film.
18. The system according to any one of claims 14 to 17, wherein the first adhesive and the second adhesive cover less than a side of the drape.
19. The system according to any one of claims 14 to 18, wherein the first adhesive has a thickness between about 30 microns and about 65 microns, and the second adhesive layer has a thickness between about 100 microns and about 400 microns.

20. The system according to any one of claims 14 to 19, wherein:
 - the first adhesive comprises a plurality of cells; and
 - the second adhesive substantially covers the drape between the plurality of cells.
21. The system of claim 20, wherein the cells of the first adhesive are equidistantly separated from adjacent cells of the first adhesive.
22. The system according to any one of claims 14 to 19, wherein the second adhesive comprises one or more periodic wave-shaped strips of the second adhesive that propagate parallel to an edge of the drape.
23. The system according to any one of claims 14 to 19 and 22, wherein the first adhesive comprises a strip of adhesive having a periodic wave-shape that propagates parallel to an edge of the drape.
24. The system of claim 23, wherein the strip of adhesive has a peak-to-peak amplitude substantially equivalent to a width of the drape.
25. The system according to any one of claims 14 to 24, wherein the first adhesive is an acrylic adhesive, and the second adhesive is a silicone adhesive.
26. The system of claim 17, wherein the flexible film comprises a polyurethane film.
27. The system of claim 17, wherein the flexible film has a moisture vapor transfer rate between about 300 g/m²/24 hours to about 14,400 g/m²/24 hours.
28. The system of claim 27, wherein the flexible film has a moisture vapor transfer rate of about 1000 g/m²/24 hours.
29. The system according to any one of claims 14 to 28, wherein the first adhesive is an acrylic adhesive, and the second adhesive is a silicone adhesive.
30. A method of manufacturing a medical drape, the method comprising:
 - providing a flexible film;

disposing a first adhesive on a side of the flexible film in a first pattern; and disposing a second adhesive on the side of the flexible film in a second pattern, so that the first adhesive and the second adhesive cover substantially different portions of the flexible film, the second adhesive having a thickness greater than a thickness of the first adhesive, the second adhesive having a tackiness less than a tackiness of the first adhesive.

31. The method of claim 30, wherein disposing the first adhesive and the second adhesive comprises substantially covering the side of the flexible film with the first adhesive and the second adhesive.
32. The method according to claim 30 or claim 31, wherein disposing the first adhesive and the second adhesive comprises covering a portion of the side of the flexible film.
33. Use of a system for treating a tissue site with reduced pressure, the system including:
 - a manifold configured for distributing reduced pressure proximate to a tissue site and configured for coupling to a reduced-pressure source; and
 - a medical drape configured to be disposed over the tissue site, the medical drape having a first adhesive and a second adhesive coupled to the medical drape, the second adhesive registered with the first adhesive so that the first and second adhesives cover substantially different portions of the medical drape, wherein the second adhesive has a thickness greater than a thickness of the first adhesive;wherein the second adhesive is configured to be coupled to the tissue site to form a sealing coupling between the drape and the tissue site;
wherein the drape is positionable; and
wherein the first adhesive is configured to have a force applied thereto to form a bonding coupling between the drape and the tissue site.

34. Use of a system for treating a tissue site with reduced pressure in accordance with claim 33, wherein the first adhesive has a thickness between about 30 microns and about 65 microns, and the second adhesive layer has a thickness between about 100 microns and about 400 microns.
35. Use of a system for treating a tissue site with reduced pressure according to claim 33 or claim 34, wherein the first adhesive is an acrylic adhesive, and the second adhesive is a silicone adhesive.
36. Use of a system for treating a tissue site with reduced pressure according to any one of claims 33 to 35, wherein the flexible film comprises a polyurethane film.
37. Use of a system for treating a tissue site with reduced pressure according to any one of claims 33 to 36, wherein the flexible film has a moisture vapor transfer rate between about 300 g/m²/24 hours to about 14,400 g/m²/24 hours.
38. Use of a system for treating a tissue site with reduced pressure in accordance with claim 37, wherein the flexible film has a moisture vapor transfer rate of about 1000 g/m²/24 hours.
39. Use of a system for treating a tissue site with reduced pressure according to any one of claims 33 to 38, wherein the second adhesive has a tackiness less than a tackiness of the first adhesive.

40. A medical drape comprising:

a flexible film;

a first adhesive disposed on a first portion of the flexible film in a first pattern; and

a second adhesive disposed on a second portion of the flexible film in a second pattern, the second pattern registered with the first pattern so that the first portion and the second portion cover substantially different portions of the flexible film;

wherein the first pattern comprises:

a first row of the first adhesive adjacent to an edge of the flexible film, the first row having a plurality of cells, each cell separated from adjacent cells of the first row, and

a second row of the first adhesive separated from the edge of the flexible film, the second row having a plurality of cells offset from the cells of the first row, each cell separated from adjacent cells of the second row;

wherein the second pattern comprises one or more periodic wave-shaped strips of the second adhesive, the periodic wave-shaped strips having maximum and minimum amplitudes that correspond with medial portions of the cells of the first and second rows, respectively, so that the periodic wave-shaped strips enclose the cells of the first and second rows that propagate parallel to the edge of the flexible film.

41. A system for treating a tissue site with reduced pressure, the system comprising:

- a manifold for distributing reduced pressure proximate to a tissue site;
- a reduced-pressure source fluidly coupled to the manifold;
- a drape; and
- a first adhesive and a second adhesive coupled to the drape, the second adhesive registered with the first adhesive so that the first adhesive and the second adhesive cover substantially different portions of the drape;

wherein the first adhesive comprises:

- a first row of cells adjacent to an outer edge of the drape, the first row having a plurality of cells, each cell separated from an adjacent cell of the first row; and
- a second row of cells separated from the edge of the drape, the second row having a plurality of cells offset from the cells of the first row, each cell separated from an adjacent cell of the second row;

wherein the second adhesive comprises one or more periodic wave-shaped strips, the periodic wave-shaped strips having maximum and minimum amplitudes that correspond with centers of the cells of the first and the second rows of cells, respectively, so that the periodic wave-shaped strips enclose the cells of the first and the second rows.

42. A method of manufacturing a medical drape, the method comprising:
- providing a flexible film;
 - disposing a first adhesive on a side of the flexible film in a first pattern; and
 - disposing a second adhesive on the side of the flexible film in a second pattern, so that the first adhesive and the second adhesive cover substantially different portions of the flexible film; the second adhesive having a tackiness less than a tackiness of the first adhesive;
- wherein disposing the first adhesive on the side of the flexible film in the first pattern comprises:
- moving the flexible film past a rotary member so that the flexible film contacts a portion of an exterior of the rotary member while the flexible film moves linearly relative to the rotary member,
 - supplying the first adhesive to an interior of the rotary member, and
 - compressing the first adhesive through openings of the rotary member onto the flexible film, the openings being formed in the exterior surface of the rotary member in the first pattern.
43. The method of claim 42, wherein disposing a second adhesive on the side of the flexible film in a second pattern comprises:
- moving the flexible film past a rotary member so that the flexible film contacts a portion of an exterior of the rotary member while the flexible film moves linearly relative to the rotary member;
 - supplying the second adhesive to an interior of the rotary member; and
 - compressing the second adhesive through openings of the rotary member onto the flexible film, the openings being formed in the exterior surface of the rotary member in the second pattern.

44. A method of manufacturing a medical drape, the method comprising:
- providing a flexible film;
 - disposing a first adhesive on a side of the flexible film in a first pattern; and
 - disposing a second adhesive on the side of the flexible film in a second pattern, so that the first adhesive and the second adhesive cover substantially different portions of the flexible film; the second adhesive having a tackiness less than a tackiness of the first adhesive;
- wherein disposing a first adhesive on the side of the flexible film in a first pattern comprises:
- providing one or more extruders configured to receive the first adhesive and operable to extrude the first adhesive onto the flexible film,
 - moving the flexible film relative to the extruders, and
 - actuating the extruders to extrude the first adhesive onto the flexible film as the flexible film moves linearly past the extruders.
45. The method of claim 44, wherein disposing a second adhesive on the side of the flexible film in a second pattern comprises:
- providing one or more extruders configured to receive the second adhesive and to extrude the second adhesive onto the flexible film;
 - moving the flexible film in a first direction relative to the extruders;
 - moving the extruders linearly in a second direction perpendicular to the movement of the flexible film, the movement being cyclical between a first edge of the flexible film and a second edge of the flexible film; and
 - actuating the extruders to extrude the second adhesive through the extruders onto the first side of the flexible film as the flexible film moves past the extruders.

46. A method of manufacturing a medical drape, the method comprising:

- providing a flexible film;
- disposing a first adhesive on a side of the flexible film in a first pattern; and
- disposing a second adhesive on the side of the flexible film in a second pattern, so
 - that the first adhesive and the second adhesive cover substantially different portions of the flexible film; the second adhesive having a tackiness less than a tackiness of the first adhesive;

wherein disposing a first adhesive on the side of the flexible film in a first pattern comprises:

- providing an extruder configured to receive the first adhesive and to extrude the first adhesive onto the flexible film,
- moving the flexible film linearly relative to the extruder,
- actuating the extruder to extrude the first adhesive through the extruder onto the flexible film as the flexible film moves linearly past the extruder,
- moving the extruder linearly perpendicular to the movement of the flexible film, the movement being cyclical between a first edge of the flexible film and a second edge of the flexible film, and
- moving the flexible film perpendicular to the extruder, the first pattern being a periodic wave-shaped strip in response.

47. A method of manufacturing a medical drape, the method comprising:
- providing a flexible film;
 - disposing a first adhesive on a side of the flexible film in a first pattern; and
 - disposing a second adhesive on the side of the flexible film in a second pattern, so
 - that the first adhesive and the second adhesive cover substantially different portions of the flexible film; the second adhesive having a tackiness less than a tackiness of the first adhesive;
- wherein the disposing a first adhesive on the side of the flexible film in a first pattern comprises:
- providing a transfer cylinder having the first pattern engraved on an exterior portion of the transfer cylinder,
 - coating the transfer cylinder with the first adhesive,
 - pressing the transfer cylinder onto the flexible film as the flexible film moves linearly past the transfer cylinder to deposit the first adhesive on the flexible film, and
 - curing the first adhesive on the flexible film.
48. The method of claim 47, wherein disposing a second adhesive on the side of the flexible film in a second pattern comprises:
- providing a transfer cylinder having the second pattern engraved on an exterior portion of the transfer cylinder;
 - coating the transfer cylinder with the second adhesive;
 - pressing the transfer cylinder onto the flexible film as the flexible film moves linearly past the transfer cylinder to deposit the second adhesive on the flexible film; and
 - curing the second adhesive on the flexible film.

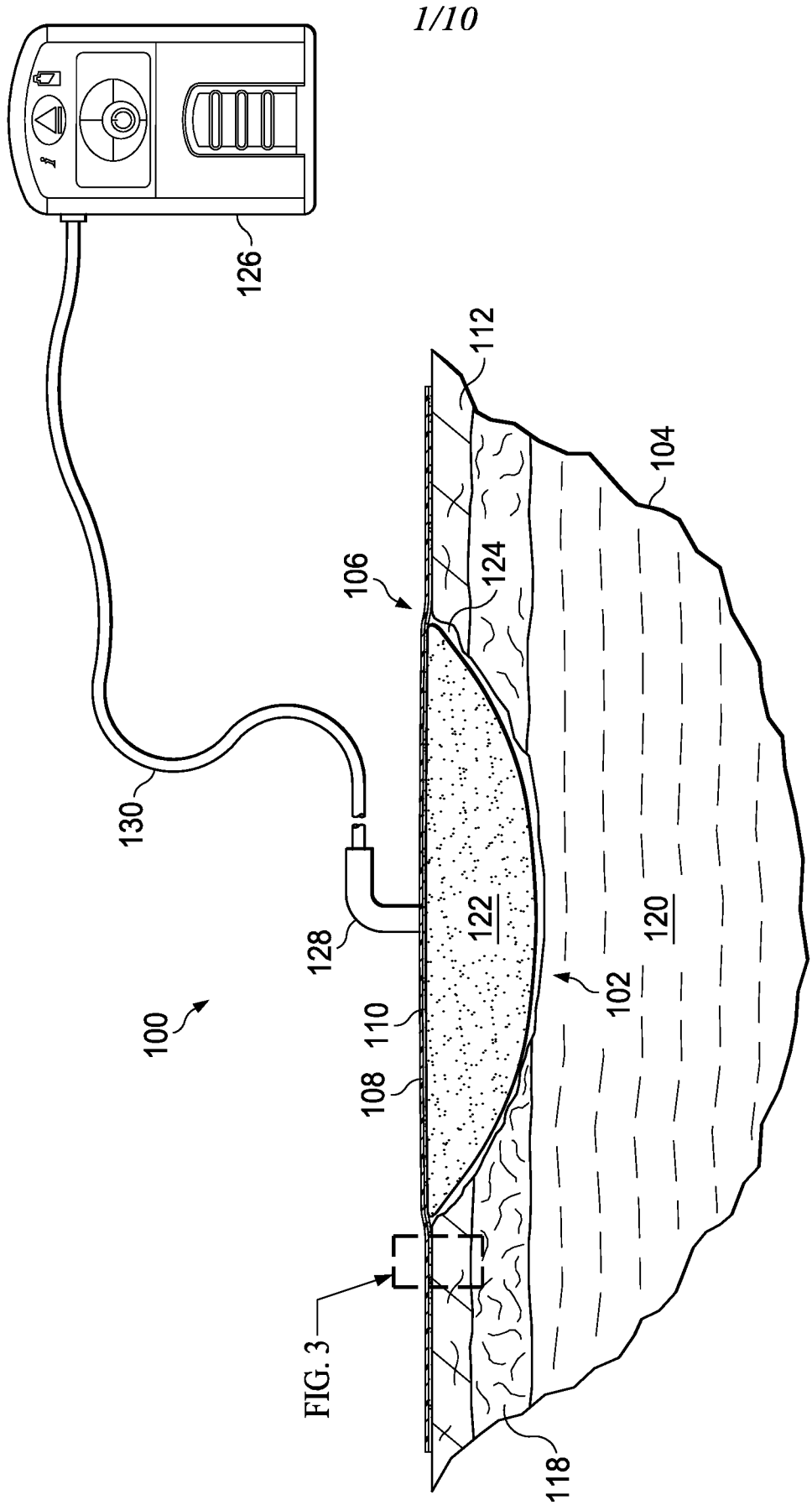

FIG. 1

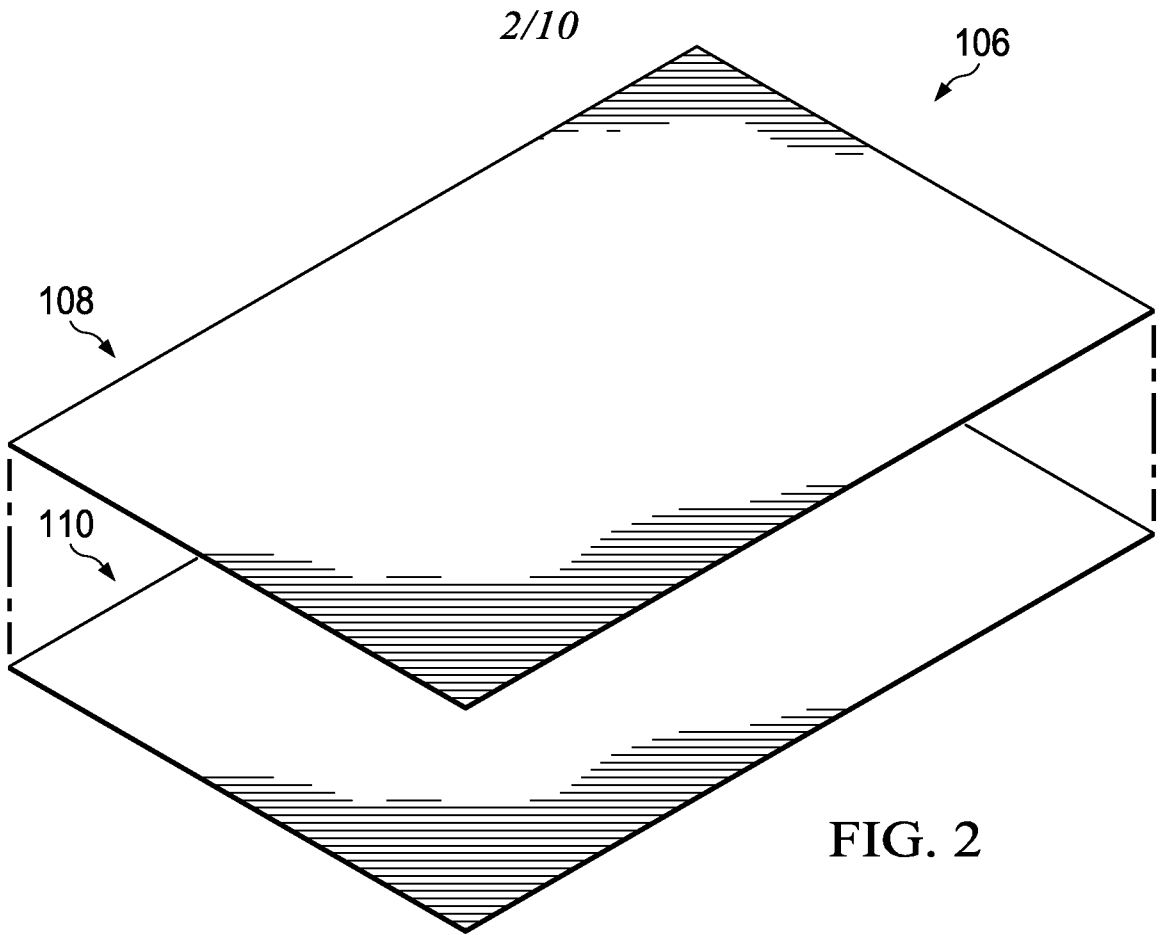

FIG. 2

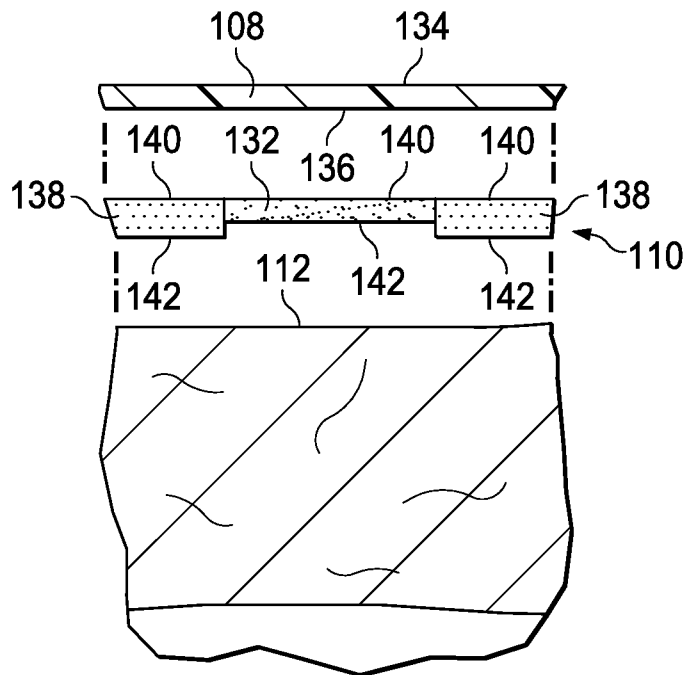

FIG. 3A

3/10

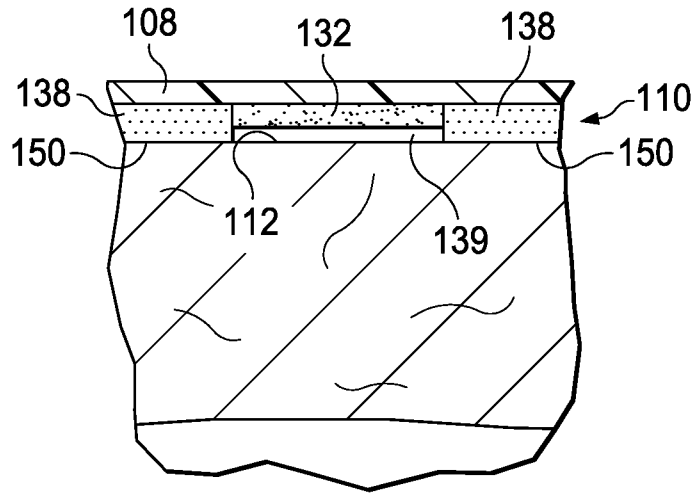

FIG. 3B

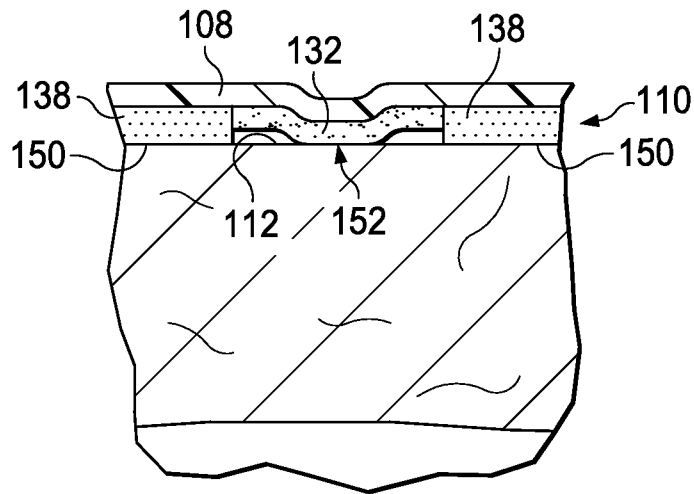
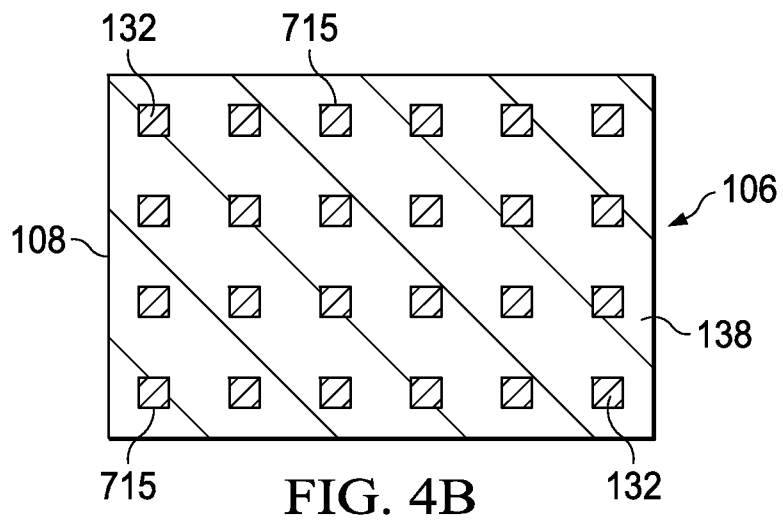
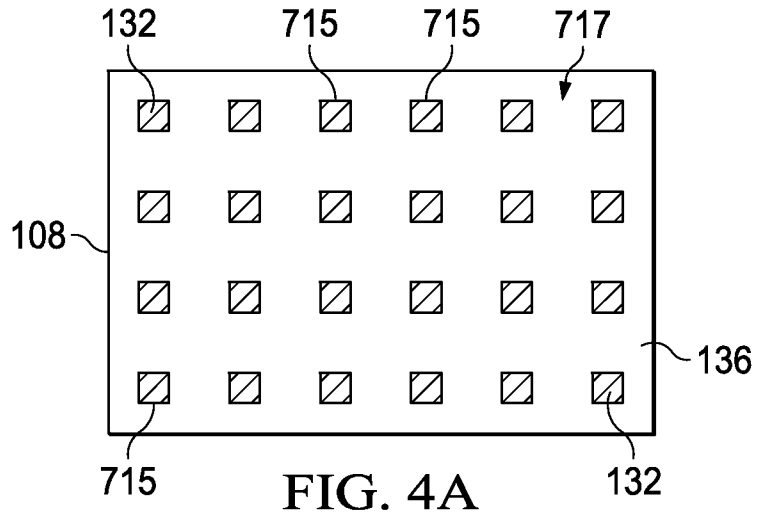

FIG. 3C



5/10

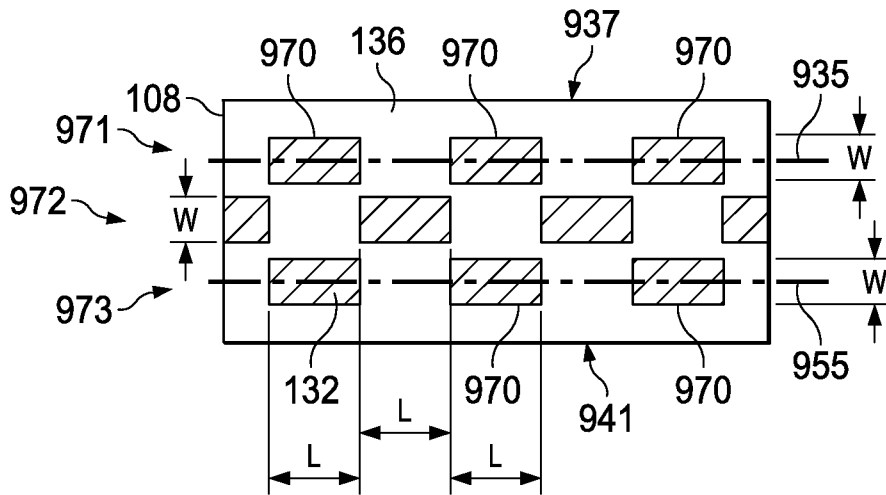

FIG. 5A

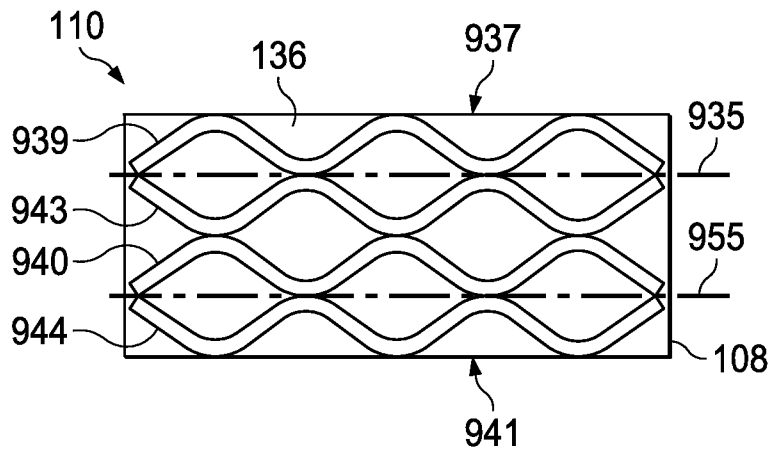

FIG. 5B

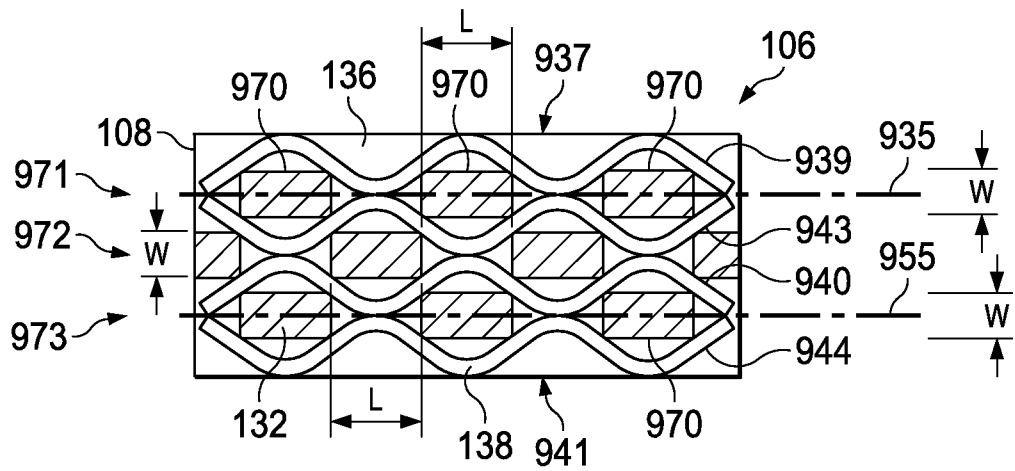

FIG. 5C

6/10

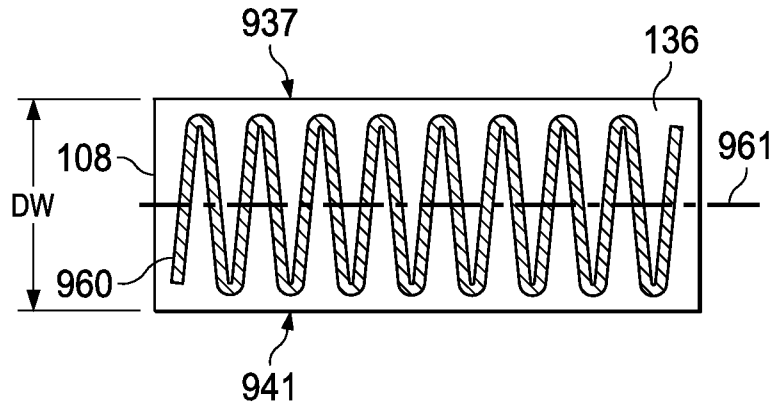

FIG. 6A

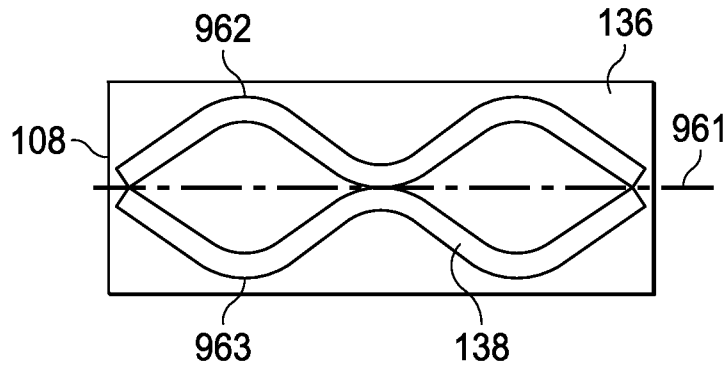

FIG. 6B

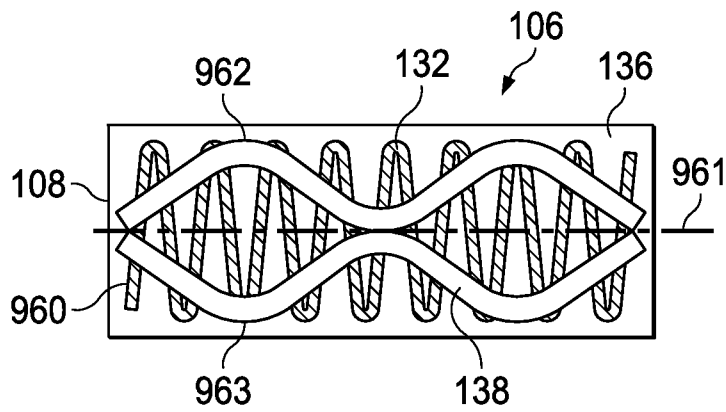

FIG. 6C

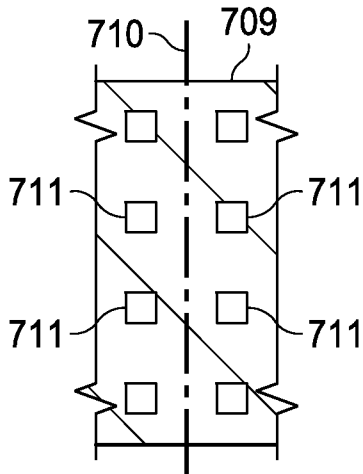

FIG. 7B

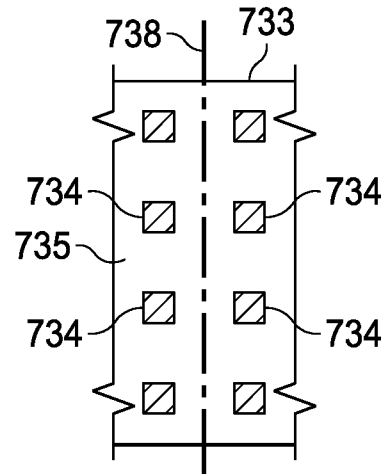

FIG. 7C

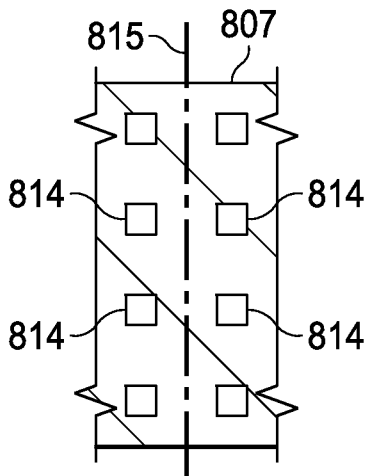

FIG. 8B

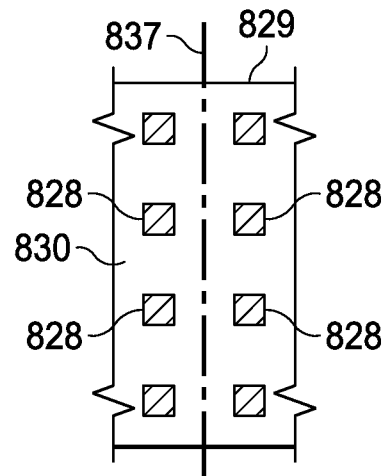

FIG. 8C

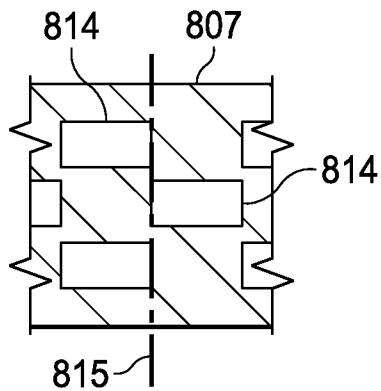

FIG. 8D

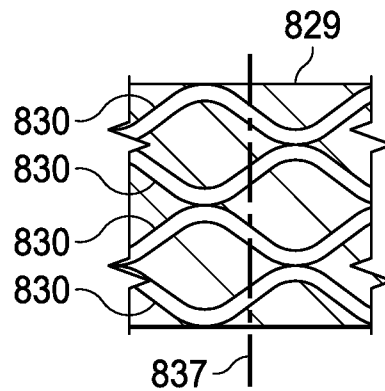

FIG. 8E

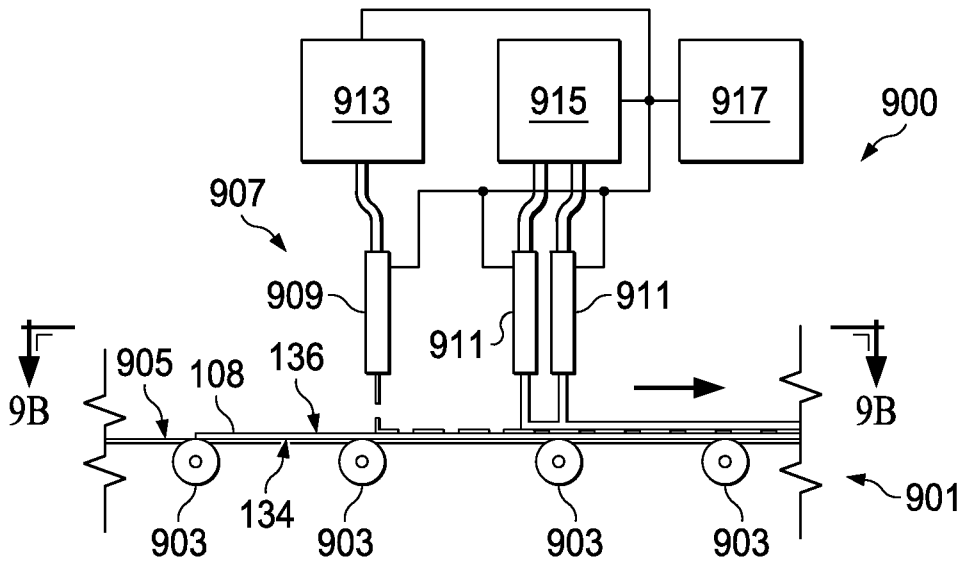

FIG. 9A

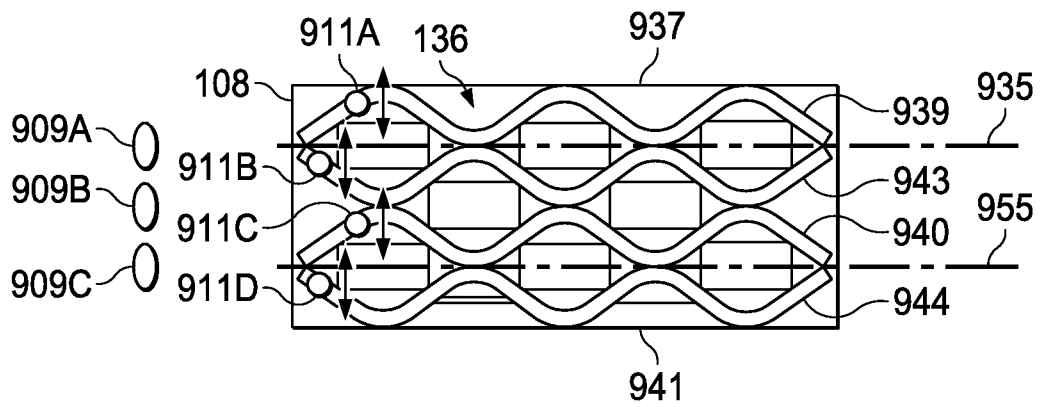

FIG. 9B

10/10

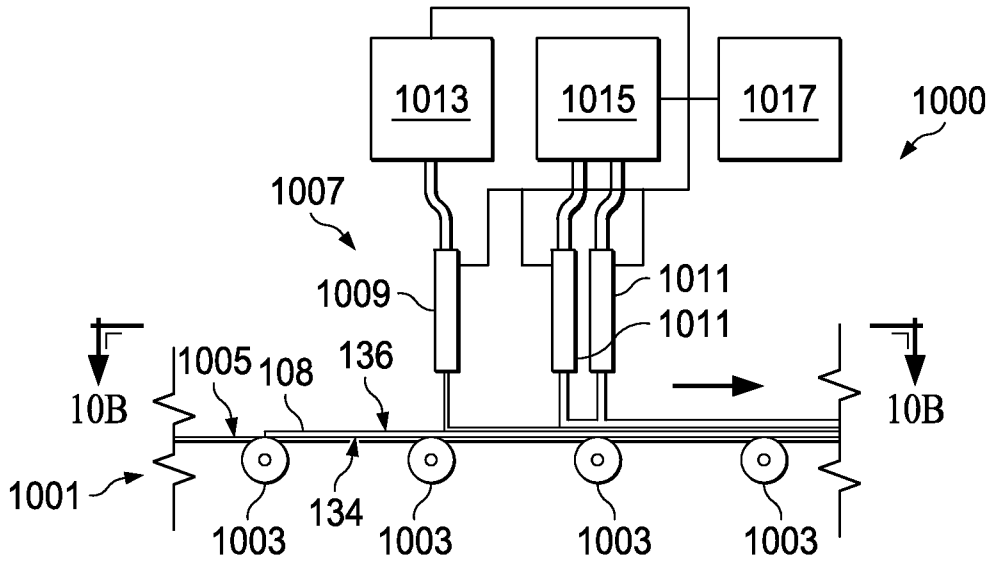

FIG. 10A

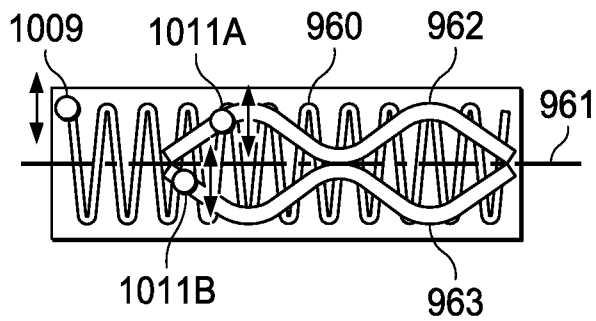

FIG. 10B

