



## INTERNATIONAL APPLICATION PUBLISHED UNDER THE PATENT COOPERATION TREATY (PCT)

<b>(51) International Patent Classification :</b>  <b>H04L 25/02, 5/20</b>	<b>A3</b>	<b>(11) International Publication Number:</b> <b>WO 95/26128</b>  <b>(43) International Publication Date:</b> 5 October 1995 (05.10.95)
<b>(21) International Application Number:</b> PCT/US95/03609 <b>(22) International Filing Date:</b> 21 March 1995 (21.03.95) <b>(30) Priority Data:</b> 08/219,664                      29 March 1994 (29.03.94)                      US <b>(71) Applicant:</b> APPLE COMPUTER, INC. [US/US]; 20525 Mariani Avenue, Cupertino, CA 95014 (US). <b>(72) Inventors:</b> VAN BRUNT, Roger, W.; 1214 A Stanyan Street, San Francisco, CA 94117 (US). OPRESCU, Florin, A.; 833 Fife Way, Sunnyvale, CA 94087 (US). <b>(74) Agents:</b> SCHELLER, James, C. et al.; Blakely, Sokoloff, Taylor & Zafman, 7th floor, 12400 Wilshire Boulevard, Los Angeles, CA 90025-1026 (US).	<b>(81) Designated States:</b> AM, AT, AT (Utility model), AU, BB, BG, BR, BY, CA, CH, CN, CZ, CZ (Utility model), DE, DE (Utility model), DK, DK (Utility model), EE, EE (Utility model), ES, FI, FI (Utility model), GB, GE, HU, JP, KE, KG, KP, KR, KZ, LK, LR, LT, LU, LV, MD, MG, MN, MW, MX, NL, NO, NZ, PL, PT, RO, RU, SD, SE, SG, SI, SK, SK (Utility model), TJ, TM, TT, UA, UG, UZ, VN, European patent (AT, BE, CH, DE, DK, ES, FR, GB, GR, IE, IT, LU, MC, NL, PT, SE), OAPI patent (BF, BJ, CF, CG, CI, CM, GA, GN, ML, MR, NE, SN, TD, TG), ARIPO patent (KE, MW, SD, SZ, UG).  <b>Published</b> <i>With international search report.</i> <i>Before the expiration of the time limit for amending the claims and to be republished in the event of the receipt of amendments.</i>  <b>(88) Date of publication of the international search report:</b> 26 October 1995 (26.10.95)	

**(54) Title:** COMMON MODE COMPENSATION CIRCUIT**(57) Abstract**

In a driver circuit for a twisted pair cable, a compensator for preventing appreciable common mode current flow into or out of the twisted pair cable in response to the device receiving a wide range of common mode voltage bias levels. A wide range of external bias voltages may be received as a result of variations in the ground node voltages of two coupled devices. The compensator circuit utilizes a feed back loop and monitors the bias voltage received on the twisted pair cable. As the magnitude of the common mode current increases due to external bias voltage variation from a reference bias voltage, the current flow of prochannel transistors, coupled in an arrangement of the present invention, is increased (or decreased, as necessary) so that reduced common mode current flows onto the twisted pair cable. The present invention reduces appreciable common mode current flow through the twisted pair cable from the driver that are due to variations in the external bias voltage between communication devices. The present invention provides high common mode output impedance for the driver circuit by altering the effective common mode early voltage characteristics of the driver circuit while utilizing shorter channel length transistors for high speed communication capacity. The present invention also offers reduced current supply capacity of the common mode bias voltage source. The present invention operates ideally within driver circuits compatible with the IEE P1394 communication standard.

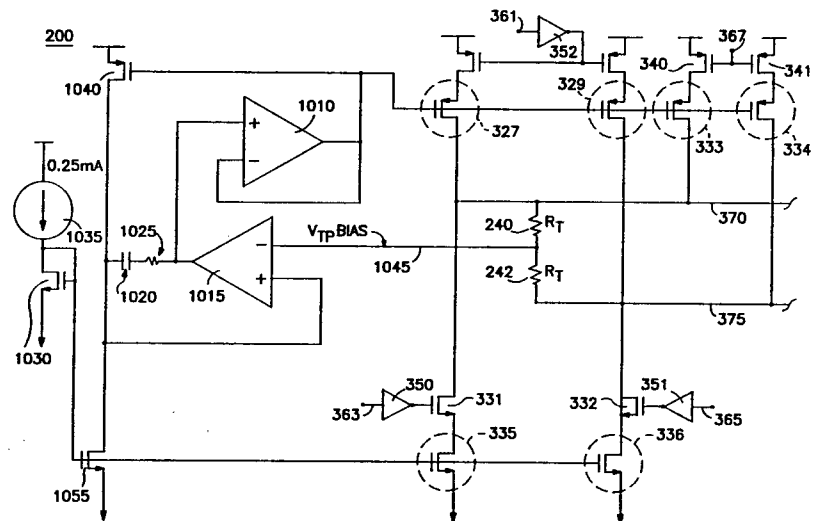

**FOR THE PURPOSES OF INFORMATION ONLY**

Codes used to identify States party to the PCT on the front pages of pamphlets publishing international applications under the PCT.

AT	Austria	GB	United Kingdom	MR	Mauritania
AU	Australia	GE	Georgia	MW	Malawi
BB	Barbados	GN	Guinea	NE	Niger
BE	Belgium	GR	Greece	NL	Netherlands
BF	Burkina Faso	HU	Hungary	NO	Norway
BG	Bulgaria	IE	Ireland	NZ	New Zealand
BJ	Benin	IT	Italy	PL	Poland
BR	Brazil	JP	Japan	PT	Portugal
BY	Belarus	KE	Kenya	RO	Romania
CA	Canada	KG	Kyrgystan	RU	Russian Federation
CF	Central African Republic	KP	Democratic People's Republic of Korea	SD	Sudan
CG	Congo	KR	Republic of Korea	SE	Sweden
CH	Switzerland	KZ	Kazakhstan	SI	Slovenia
CI	Côte d'Ivoire	LI	Liechtenstein	SK	Slovakia
CM	Cameroon	LK	Sri Lanka	SN	Senegal
CN	China	LU	Luxembourg	TD	Chad
CS	Czechoslovakia	LV	Latvia	TG	Togo
CZ	Czech Republic	MC	Monaco	TJ	Tajikistan
DE	Germany	MD	Republic of Moldova	TT	Trinidad and Tobago
DK	Denmark	MG	Madagascar	UA	Ukraine
ES	Spain	ML	Mali	US	United States of America
FI	Finland	MN	Mongolia	UZ	Uzbekistan
FR	France			VN	Viet Nam
GA	Gabon				

# INTERNATIONAL SEARCH REPORT

International Application No  
PCT/US 95/03609

<b>A. CLASSIFICATION OF SUBJECT MATTER</b> IPC 6 H04L25/02 H04L5/20				
According to International Patent Classification (IPC) or to both national classification and IPC				
<b>B. FIELDS SEARCHED</b>				
Minimum documentation searched (classification system followed by classification symbols) IPC 6 H04L				
Documentation searched other than minimum documentation to the extent that such documents are included in the fields searched				
Electronic data base consulted during the international search (name of data base and, where practical, search terms used)				
<b>C. DOCUMENTS CONSIDERED TO BE RELEVANT</b>				
Category	Citation of document, with indication, where appropriate, of the relevant passages	Relevant to claim No.		
A	DE-C-21 824 (SIEMENS) 14 July 1882  see the whole document ---	1,7,12, 13,22,28		
A	PROCEEDINGS OF THE BIPOLAR CIRCUITS AND TECHNOLOGY MEETING, MINNEAPOLIS, SEPT. 17 - 18, 1990, no. -, 17 September 1990 - 18 September 1990 JOPKE J, pages 144-147, XP 000202471 SUNDSTROM R ET AL 'A LOW POWER DIFFERENTIAL BUS UTILIZING NOVEL SPLIT LEVEL BUS TECHNIQUE' see page 144, right column, paragraph 1 see figures 2,3 --- -/--	1,7,12, 13,22,28		
<table style="width: 100%; border: none;"> <tr> <td style="width: 50%; border: none;"><input checked="" type="checkbox"/> Further documents are listed in the continuation of box C.</td> <td style="width: 50%; border: none;"><input checked="" type="checkbox"/> Patent family members are listed in annex.</td> </tr> </table>			<input checked="" type="checkbox"/> Further documents are listed in the continuation of box C.	<input checked="" type="checkbox"/> Patent family members are listed in annex.
<input checked="" type="checkbox"/> Further documents are listed in the continuation of box C.	<input checked="" type="checkbox"/> Patent family members are listed in annex.			
* Special categories of cited documents :				
<table style="width: 100%; border: none;"> <tr> <td style="width: 50%; border: none;">                     *A* document defining the general state of the art which is not considered to be of particular relevance                      *E* earlier document but published on or after the international filing date                      *L* document which may throw doubts on priority claim(s) or which is cited to establish the publication date of another citation or other special reason (as specified)                      *O* document referring to an oral disclosure, use, exhibition or other means                      *P* document published prior to the international filing date but later than the priority date claimed                 </td> <td style="width: 50%; border: none;">                     *T* later document published after the international filing date or priority date and not in conflict with the application but cited to understand the principle or theory underlying the invention                      *X* document of particular relevance; the claimed invention cannot be considered novel or cannot be considered to involve an inventive step when the document is taken alone                      *Y* document of particular relevance; the claimed invention cannot be considered to involve an inventive step when the document is combined with one or more other such documents, such combination being obvious to a person skilled in the art.                      *&amp;* document member of the same patent family                 </td> </tr> </table>			*A* document defining the general state of the art which is not considered to be of particular relevance *E* earlier document but published on or after the international filing date *L* document which may throw doubts on priority claim(s) or which is cited to establish the publication date of another citation or other special reason (as specified) *O* document referring to an oral disclosure, use, exhibition or other means *P* document published prior to the international filing date but later than the priority date claimed	*T* later document published after the international filing date or priority date and not in conflict with the application but cited to understand the principle or theory underlying the invention *X* document of particular relevance; the claimed invention cannot be considered novel or cannot be considered to involve an inventive step when the document is taken alone *Y* document of particular relevance; the claimed invention cannot be considered to involve an inventive step when the document is combined with one or more other such documents, such combination being obvious to a person skilled in the art. *&* document member of the same patent family
*A* document defining the general state of the art which is not considered to be of particular relevance *E* earlier document but published on or after the international filing date *L* document which may throw doubts on priority claim(s) or which is cited to establish the publication date of another citation or other special reason (as specified) *O* document referring to an oral disclosure, use, exhibition or other means *P* document published prior to the international filing date but later than the priority date claimed	*T* later document published after the international filing date or priority date and not in conflict with the application but cited to understand the principle or theory underlying the invention *X* document of particular relevance; the claimed invention cannot be considered novel or cannot be considered to involve an inventive step when the document is taken alone *Y* document of particular relevance; the claimed invention cannot be considered to involve an inventive step when the document is combined with one or more other such documents, such combination being obvious to a person skilled in the art. *&* document member of the same patent family			
Date of the actual completion of the international search  <b>18 September 1995</b>	Date of mailing of the international search report  <b>28.09.95</b>			
Name and mailing address of the ISA European Patent Office, P.B. 5818 Patentlaan 2 NL - 2280 HV Rijswijk Tel. (+ 31-70) 340-2040, Tx. 31 651 epo nl, Fax (+ 31-70) 340-3016	Authorized officer  <b>Scriven, P</b>			

**INTERNATIONAL SEARCH REPORT**

International Application No  
PCT/US 95/03609

C.(Continuation) DOCUMENTS CONSIDERED TO BE RELEVANT		
Category *	Citation of document, with indication, where appropriate, of the relevant passages	Relevant to claim No.
A	EP-A-0 568 197 (HEWLETT PACKARD CO) 3 November 1993  see abstract; figure 4 ---	2, 4, 8, 11, 14, 17, 22, 23, 25, 26, 29, 30
A	EP,A,0 303 407 (HEWLETT-PACKARD) 15 February 1989 see abstract; figure 1 see page 2, line 5 - line 17 see page 2, line 47 - line 53 ---	1, 7, 12, 13, 22, 28
A	PATENT ABSTRACTS OF JAPAN vol. 9 no. 219 (M-410) [1942] ,6 September 1985 & JP,A,60 079849 (NIPPON DENKI) see abstract -----	3, 10, 24

## INTERNATIONAL SEARCH REPORT

I. International application No.

PCT/US 95/03609

**Box I Observations where certain claims were found unsearchable (Continuation of item 1 of first sheet)**

This international search report has not been established in respect of certain claims under Article 17(2)(a) for the following reasons:

1.  Claims Nos.:  
because they relate to subject matter not required to be searched by this Authority, namely:
  
2.  Claims Nos.:  
because they relate to parts of the international application that do not comply with the prescribed requirements to such an extent that no meaningful international search can be carried out, specifically:
  
3.  Claims Nos.:  
because they are dependent claims and are not drafted in accordance with the second and third sentences of Rule 6.4(a).

**Box II Observations where unity of invention is lacking (Continuation of item 2 of first sheet)**

This International Searching Authority found multiple inventions in this international application, as follows:

1. claims 1,2,4-9,11-21,28-35: compensation for changes in bias currents
2. claims 3,10: transmission of data rate information
3. claims 22-27: communication network

1.  As all required additional search fees were timely paid by the applicant, this international search report covers all searchable claims.
  
2.  As all searchable claims could be searched without effort justifying an additional fee, this Authority did not invite payment of any additional fee.
  
3.  As only some of the required additional search fees were timely paid by the applicant, this international search report covers only those claims for which fees were paid, specifically claims Nos.:
  
4.  No required additional search fees were timely paid by the applicant. Consequently, this international search report is restricted to the invention first mentioned in the claims; it is covered by claims Nos.:

**Remark on Protest**

- The additional search fees were accompanied by the applicant's protest.
- No protest accompanied the payment of additional search fees.

# INTERNATIONAL SEARCH REPORT

Information on patent family members

International Application No

PCT/US 95/03609

Patent document cited in search report	Publication date	Patent family member(s)	Publication date
DE-C-21824		NONE	
EP-A-0568197	03-11-93	US-A- 5206602 JP-A- 6224659	27-04-93 12-08-94
EP-A-303407	15-02-89	CA-A- 1321416 DE-D- 3852798 DE-T- 3852798 JP-A- 1091554 US-A- 4875205	17-08-93 02-03-95 18-05-95 11-04-89 17-10-89