

*J. S. Bodge.*  
*Grain Winnower.*

*No. 40,548.*

*Patented Nov. 10, 1863.*

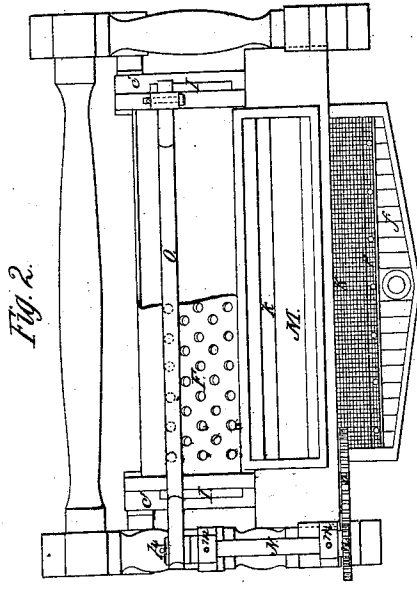
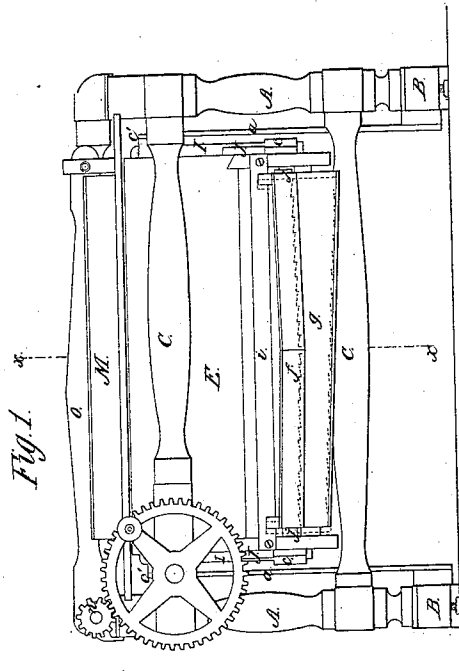
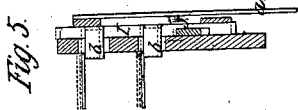
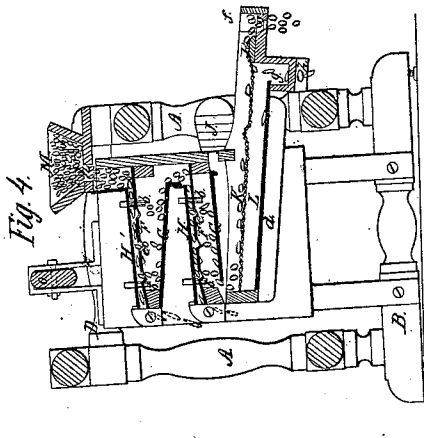
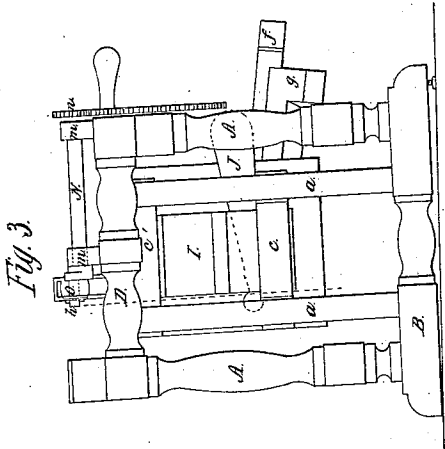

*Witnesses,*  
*James H. Gordon*  
*Chas Smith*

*Inventor,*  
*John S. Bodge*

# UNITED STATES PATENT OFFICE.

JOHN S. BODGE, OF BATH, NEW YORK.

## IMPROVEMENT IN GRAIN-SEPARATORS.

Specification forming part of Letters Patent No. 40,548, dated November 10, 1863.

*To all whom it may concern:*

Be it known that I, JOHN S. BODGE, of Bath, in the county of Steuben and State of New York, have invented a new and Improved Grain-Separator; and I do hereby declare that the following is a full, clear, and exact description of the same, reference being had to the accompanying drawings, making part of this specification, in which—

Figure 1 is a front elevation of a machine embodying my invention. Fig. 2 is a plan of the same. Fig. 3 is an end elevation of the same. Fig. 4 is a transverse section taken in the line *xx* of Fig. 1. Fig. 5 is a vertical section of one end of the riddle-frame, showing the brackets, slide, and wedge.

Similar letters of reference indicate corresponding parts in the several figures.

The nature of my invention consists, first, in slides having inwardly-projecting arms or brackets, in combination with tapering keys for adjusting the same; second, the adjustable imperforate plate for holding the oats which are to be separated from the wheat flatwise upon the riddles, in combination with the riddles; third, the inclined screen having one or more ridges across it for the purpose of separating from the wheat the short oats which pass through the riddles; fourth, the shoe, adapted to have longitudinal movement in the riddle-frame, in combination with the riddles; fifth, surrounding a portion of each of the perforations of the riddles at bottom with a sloping flange; sixth, forming the bottom of the trough with offsets or steps for the purpose of preventing a retrograde movement of the wheat in its passage to the place of delivery, all as will be hereinafter fully explained.

To enable others skilled in the art to which my invention appertains to fully understand and use the same, I will proceed to describe its construction and operation.

The frame on which the working parts of the machine are supported is composed of four wooden posts, A, rising from opposite ends of the two wooden sills B, and connected together by side and end rails, C D, respectively. Attached to the inner side of the sills B, equidistant from the center and rising to nearly the top of the frame, are two slender like strips of wood, *a a*, attached at their upper extremities to and supporting a frame, E, which has a reciprocating oscillating motion.

Secured in the frame E are two riddles, F F', which are slightly inclined toward the rear side of the machine. Below the riddle F, and inclined correspondingly in a reverse direction, is an imperforate plate, G, and below the riddle F', and running parallel with it, is an imperforate plate, G', both plates being for the purpose of conducting the grain passing through one riddle to the top of the one immediately preceding. The perforations in the metal plates forming the riddles F and F' are made diagonally through the plates with a flange, *e*, partly surrounding each at bottom, for the purpose to be hereinafter explained. Located immediately above each of the riddles is an imperforate plate, H, supported at each end on two arms or brackets, *b b*, (seen in figure,) which protrude through vertical slots in the end pieces of the frame E from slides I, which are adapted to move up and down in box-straps *c c'* or other suitable guides attached to the frame E on the outside. When it is desired to enlarge the space between the riddles and imperforate plates H, for the purpose of allowing larger grain to pass between them, the slides are moved upward by the tapering keys J, which are driven in between a shoulder on the slides I and the lower box-straps *c*. As these keys J are retracted, the slides by gravity descend, and with them the imperforate plates H. Beneath the riddle F', and supported in an inclined position in the frame E on guides *d d*, Figs. 1 and 4, is a shoe, L, provided with a wire screen, K, which empties into a trough, *f*. The bottom of the shoe terminates in front in an inclined trough, *g*, which is provided at its lower end with a discharge-aperture, *h*, Fig. 4. The shoe L is adapted to have a slight longitudinal movement in the frame E independent of the riddles, and it is kept from lateral displacement by a bar, *i*. At each end the shoe L is provided with a strip of cloth, rubber, or other soft material, *j*, Fig. 1, which acts as a cushion to lessen the shock to the shoe and frame, as the former is thrown from side to side of the latter by the movements of the same.

M is a hopper or receptacle for the grain to be separated and cleaned. This hopper in the accompanying illustration is represented as an oblong rectangular box with downwardly-converging sides and a narrow opening, *k*, through the bottom, extending the

entire length of the box. No means of graduating the size of this opening is shown in the accompanying illustration, but any of the various modes of effecting this object may be adopted.

N is a shaft journaled horizontally in boxes *m* on top of one of the end rails. One end of this shaft is provided with a pinion, *n*, gearing into a large cog driving-wheel, and the other end is provided with an eccentric wrist-pin, *p*, which imparts a reciprocating motion to the riddles F F' and shoe L through the intervention of a pitman, O', which is connected to the frame by a pin and box-strap, the pitman working between the vertical sides of the strap on the pin.

The grain to be separated and cleaned being placed in the hopper M and the machine put in motion, it falls onto the upper end of the riddle F, (shown in Figs. 2 and 4,) whence it slides over the same, the wheat and chaff falling through the perforations onto the oppositely-inclined imperforate plate, G, whence they are conducted to the upper end of the riddle F', thence over and through this riddle, in the same manner as in the first instance, onto the imperforate plate G', over the lower end of which they are precipitated onto the upper end of the wire screen K, descending which, and being separated thereby from by the chaff and oats smaller than wheat, they pass into the trough *f*, whence they are discharged through a central aperture in a marketable condition. The screen K should be coarse enough to pass chaff and short oats through it, but not grains of wheat. The oats, which are mixed with the wheat, being of nearly the same size as the wheat, except in length, if allowed to bound upon the riddles F and F', will pass through the perforations thereof with the wheat, but if kept flatwise upon the riddles they will slide over the perforations without passing through them, and escape at the lower end of the riddle, as represented in Fig. 4 of the drawings. The flange surrounding the back part of the perforations in the riddle at bottom is to prevent oats which are but a trifle longer than the grains of wheat from tipping up and working through the perforations with the wheat. The movable imperforate plates H H' are for the purpose of keeping the oats flatwise upon the riddles F and F', and thus prevent them from passing through the same with the wheat, which they would do if allowed to turn upon end. These plates at the commencement of the process of separating

and cleaning grain should be adjusted so as to leave a space between them and the riddle of sufficient size to allow the largest size wheat to pass through without more than barely touching the former. As it sometimes happens that in a quantity of grain to be separated there are oats no larger than a large grain of wheat, it is necessary to provide some means of separating these short oats from the wheat. Usually this is done by means of a fan-blast. The provision made in my invention to effect this object is to have one or more ridges, P, Figs. 2 and 4, formed across the wire screen, which is too fine to permit the passage of wheat through it, which ridge or ridges serve to catch the oats which descend the screen with the wheat, and turn them upon end or into nearly a vertical position, when, being smaller than the wheat, they pass readily through the meshes of the screen, along with the chaff, and thus are prevented from mixing with the cleaned wheat. At every movement of the shoe the wheat in its trough advances one or more steps toward the center until it finally passes through the discharge-opening into a proper receptacle ready to receive it. The chaff and short oats passing through the screen are in like manner conducted to the lower end of the trough *g*, where they escape through the opening *h*.

Having thus described my invention, what I claim as new, and desire to secure by Letters Patent, is—

1. The slides I, having inwardly-projecting arms or brackets *b*, in combination with the tapering keys *j*, as and for the purpose specified.
2. The adjustable imperforate plates H H', in combination with the riddles F and F', as and for the purpose specified.
3. The inclined screen K, having one or more ridges, P, across it, as and for the purpose specified.
4. The shoe L, adapted to have longitudinal movement in the frame E, in combination with the riddles F and F' and imperforate plates H and H', as described.
5. Surrounding a portion of each of the perforations in the riddles F and F' at bottom with a sloping flange, *e*, as and for the purpose specified.

JOHN S. BODGE.

Witnesses:

T. W. WHITING,  
CHARLES WILSON.