

Dec. 20, 1966

J. J. COWLEY

3,292,821

COIN OPERATED OXYGEN DISPENSER

Filed July 15, 1965

2 Sheets-Sheet 1

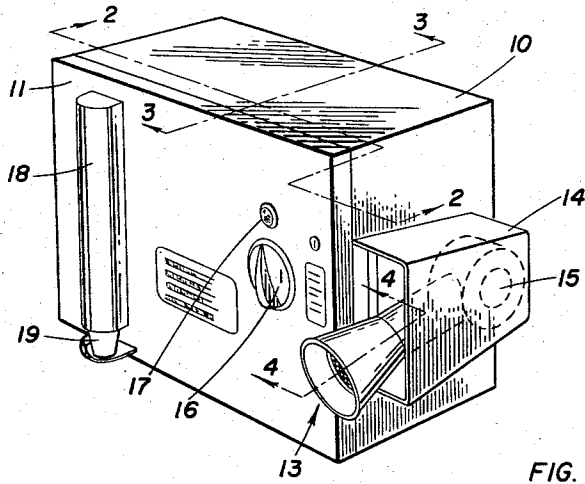

FIG. 1

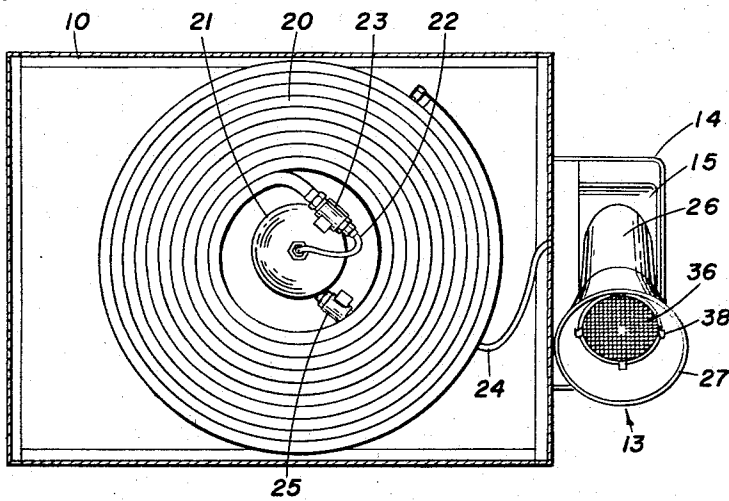

FIG. 2

INVENTOR:
JOHN J. COWLEY

BY: *Cavanagh & Norman*

Dec. 20, 1966

J. J. COWLEY

3,292,821

COIN OPERATED OXYGEN DISPENSER

Filed July 15, 1965

2 Sheets-Sheet 2

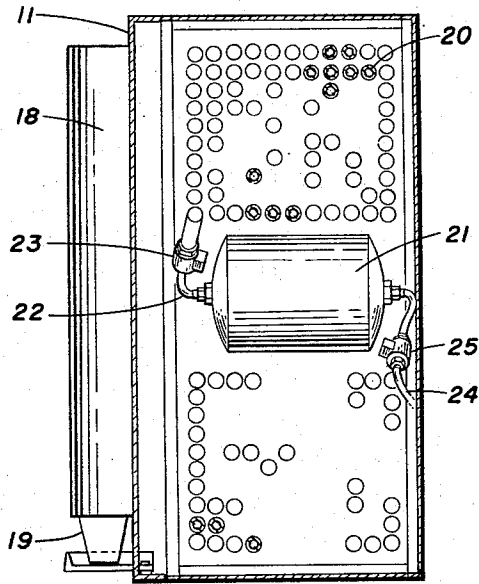

FIG. 3

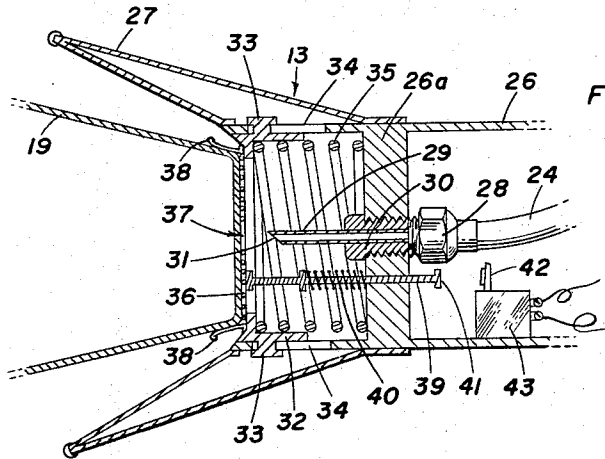

FIG. 4

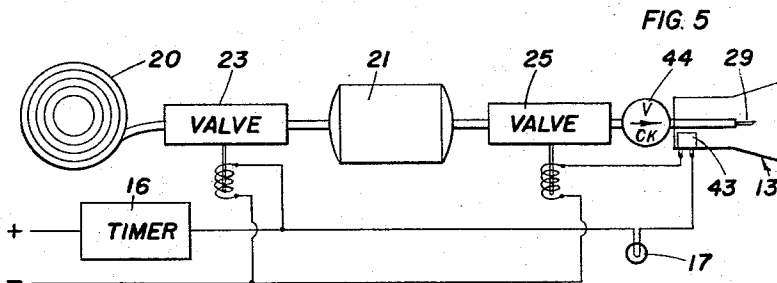

FIG. 5

INVENTOR:
JOHN J. COWLEY

BY: *Cavanagh & Norman*

1

3,292,821

COIN OPERATED OXYGEN DISPENSER

John James Cowley, 238 Carmichael Ave.,
Toronto, Ontario, Canada

Filed July 15, 1965, Ser. No. 472,088

10 Claims. (Cl. 222-2)

The invention relates to a coin operated oxygen dispenser.

It is well known that the breathing of air enriched with substantial quantities of additional oxygen for short periods of time can greatly accelerate recovery of persons from fatigue due to, for example, overexertion in sports, and also can be of considerable assistance in speeding the recovery of persons who have otherwise reduced the available oxygen in their bloodstream as for example by over indulgence in alcohol. For this reason, oxygen inhalators are frequently made available at sporting events and are also available in a very few social and recreational centres. However, the use of normal oxygen inhalator devices requires the assistance of a skilled operator and in addition is relatively difficult to control with a result that the charges made for the use of the oxygen are excessive and as a result such services have not been made available except in a very few instances.

It is apparent however that if such oxygen can be made available automatically without the use of an assistant and can be metered in predetermined quantities, a considerable opportunity exists for the installation of oxygen breathing equipment in a very large number of locations such as for example, swimming baths and other local sporting facilities, and also in hotels and beverage rooms. However, the provision of such an automatic oxygen breathing apparatus has generally speaking been felt to be a difficult problem due to the difficulty of storing oxygen under pressure with a sufficient degree of safety and also due to the difficulty of reducing the pressure and dispensing the oxygen in an economical and efficient manner.

Accordingly, it is a general objective of the present invention to provide a coin operated oxygen dispensing apparatus which is relatively simple and economical to build and in which the oxygen is stored in an improved manner with a high degree of safety, and in which the dispersing and breathing of the oxygen is performed in a simple manner in response to the deposit of a coin by a purchaser without the assistance of an operator, which apparatus may be constructed and operated substantially in the manner of an automatic vending machine.

More particularly, it is an objective of the present invention to provide apparatus having the foregoing advantages which is hygienic to use and is provided with disposable mask means avoiding the contamination of the apparatus by users.

More particularly, it is an objective of the present invention to provide apparatus having the foregoing advantages which is provided with means for metering the total flow of oxygen dispensed at any one sale and in addition, is provided with means for controllably restricting flow of oxygen during any one such sale so as to avoid wastage.

The foregoing and other advantages will become apparent from the following description of a preferred embodiment of the invention which will now be described with reference to the following drawings in which like reference devices refer to like parts thereof throughout the various views and diagrams and in which:

FIGURE 1 is a perspective illustration of a coin operated vending machine for dispensing oxygen according to the present invention;

FIGURE 2 is a sectional illustration along the line 2-2 of FIGURE 1;

FIGURE 3 is a sectional side elevation along the line 3-3 of FIGURE 1;

2

FIGURE 4 is a sectional side elevation greatly enlarged of a detail of the machine illustrated in FIGURE 1; and FIGURE 5 is a schematic circuit diagram.

From FIGURE 1 it will be noted that the invention comprises a wall mounted container 10 of sheet steel box-like construction and having a front closure 11 hingedly mounted thereto along one vertical side (not shown) and having locking means generally indicated as 12 located adjacent the other vertical side. An oxygen dispenser head indicated generally by the arrow 13 (to be described in more detail below) is partially enclosed within housing 14 permitting only limited upward and downward swinging movement of dispensing head 13 about pivoting axis 15, and simultaneously protecting the same from destruction due to misuse. The front closure 11 is also provided with a coin slot and timing mechanism generally indicated as 16 and a warning light 17 for indicating that the machine is in operation and a conventional hopper or magazine 18 for storing and dispensing paper cups 19 which are retained therein by swingably mounted retaining plate 18a or any other suitable similar control means.

Turning now to FIGURES 2 and 3 it will be noted that housing 10 is largely occupied by pressure container 20 for storing of compressed oxygen. Container 20 comprises a single continuous tube wound about itself in a spiral form substantially as shown to provide a greatly elongated continuous tubular pressure container capable of withstanding very high internal pressures and having a relatively thin walled structure in relation to the pressure and volume contained thereby avoiding the destructive effects of an explosion if it should take place. The details of construction of such pressure container 20 are described in co-pending United States patent application Ser. No. 450,325, filed Apr. 23, 1965 for Tubular Pressure Vessel. Vessel 20 is preferably connected to an expansion chamber 21 by means of capillary tube 22, escape of oxygen from vessel 20 to vessel 21 being controlled by the solenoid operated valve 23. Expansion vessel or chamber 21 is further connected to the oxygen dispensing head 13 by means of tube 24, passage of oxygen therefrom being controlled by solenoid operated valve 25.

Oxygen dispensing head 13 is shown in FIGURE 4 in detail and will be seen to comprise the substantially tubular rigid arm portion 26 having a generally coned shaped mouthpiece or end portion 27 fastened thereto. Within tubular arm 26 is located tube 24 at the other end of which is connected through valve 25 to expansion chamber 21 as described above. Tube 24 terminates in junction fitting 28 making screw threaded connection to injection needle 29 having a passage 30 extending therethrough and terminating in a sharpened or pointed end 31. Around needle 31 there is provided a sliding sleeve portion 32 fitting within a forward extension of tubular arm 26 and having slide members 33 extending through slots 34 formed in tubular arm 26 for the purpose. Coil spring 35 is retained by sleeve 32 and urges the same normally outwardly of tubular arm 26. Across the open mouth defined by sleeve 32 there is provided a gauze or wire mesh screen 36 having a central axial opening 37 for passage of needle point 31 therethrough and around the edges of screen 36 there are provided a series of spring steel fingers 38 for gripping the lower end of a cup 19 and holding the same in engagement with screen 36 substantially as shown in FIGURE 4. The inner side of screen 36 is in engagement with a plunger member 39 spring urged by spring 40 into engagement with screen 36 and extending slidably through partition portion 26a of tubular sleeve 26 and terminating in a contact button 41 oriented to engage spring contact 42 of electrical switch 43. For additional safety, a one-way flow control valve 44 is located close

to needle 29, in tube 24 so as to permit flow of oxygen outwardly but to prevent reverse flow of air upwardly into tube 24.

The circuit diagram of the apparatus is shown in FIGURE 5 and it will be seen that electrical power is supplied under the control of timer 16 to solenoid valve 23 and solenoid valve 25. Solenoid valve 23 is designed to supply high pressure oxygen from vessel 20 to vessel 21 and to cut off immediately a predetermined back pressure existing in vessel 21 thereby providing a predetermined unit charge in response to the deposit of a coin. Solenoid valve 25 is controlled by switch 43 and operates to pass oxygen from vessel 21 to needle 29 upon switch 43 being operated by insertion of a cup 19 between fingers 38 and depression of cup 19 so as to compress spring 35 and force needle point 31 through the base of cup 19.

In operation, a person in need of oxygen may insert a coin into coin mechanism 16 and rotate the timing device in a manner similar to for example, a parking meter or the like mechanism. Such operation will close the electrical circuit thereby applying electrical power to valves 23 and 25 and to switch 43 and will also energize warning light 17 thereby indicating that the machine is in operation. As soon as electrical power is supplied to solenoid valve 23, high pressure oxygen from container 20 is applied to expansion chamber 21 which is of a predetermined unit sale volume and, as soon as a predetermined pressure within chamber 21 is built up, valve 23 functions to cut-off further supply of oxygen thereby vending a predetermined unit quantity of oxygen in response to the insertion of a single coin. The purchaser then removes a single cup 19 from hopper 18, swinging plate member 18a swinging sideways once only to permit such dispensing. The cup 19 is then placed or fitted within spring steel fingers 38 located around the edges of screen 36 which retain the base of cup 19 in position thereon. The purchaser then pushes cup 19 inwardly against coil spring 35 until needle point 31 pierces the base of cup 19. At approximately the same moment, plunger member 39 will be depressed into contact with spring contact 42 of electrical switch 43 which in turn controls the operation of solenoid valve 25. Operation of solenoid valve 25 permits the flow of oxygen from expansion chamber 21 through tube 24 and needle 29 into the interior of cup 19 where the oxygen is available for the purchaser to inhale. Upon the purchaser having inhaled once deeply, he may permit cup 19 to be released and move forwardly under the influence of spring 35 thereby disengaging plunger 39 from switch 43 and cutting off valve 25 thereby terminating flow of oxygen into cup 19. When the purchaser is again ready to inhale a further quantity of oxygen he may again depress cup 19 against spring 35, thereby procuring a further flow of oxygen into cup 19 from expansion chamber 21. These movements may be repeated until the pressure of the oxygen stored in chamber 21 is reduced to substantially or only slightly above atmospheric pressure at which time no further oxygen will flow therefrom. If however the purchaser decides to discontinue further inhalation while some oxygen pressure remains in chamber 21 then the apparatus will be automatically switched off by the timing mechanism contained in coin mechanism 16 thereby switching off electrical supply both to solenoid valve 23 and to solenoid valve 25.

It will be noted that throughout the entire operation, and after termination of inhalation, all dead zones which might otherwise entrap and retain foreign matter are directed at a downward angle thereby ensuring that any gas or foreign matter will be ejected into the surrounding atmosphere and avoiding a build up of such matter or gas which might be harmful, and minimizing the risk of explosion. In addition, it will be understood that although the present invention has been described in connection with a partly mechanical and partly electrical operation, the entire mechanism can be operated by

mechanical means thereby avoiding the necessity for locating the mechanism at or near an electrical outlet and also for the purpose of meeting any special requirements of local authorities and safety organizations if such are in force in the particular locality.

The foregoing is a description of a preferred embodiment of the invention by way of example only and the invention is not limited to the specific features shown but contemplates all such variations as come within the spirit of the invention as defined by the following claims.

What I claim is:

1. Coin operated apparatus for dispensing gaseous oxygen and the like in predetermined unit volume and comprising: a pressure vessel for storing said gas; metering means connected thereto for regulating flow of gas volume therefrom; coin responsive control means for operation of said metering means; a dispensing head connected to said vessel and oriented to direct gas dispensed therefrom towards a purchaser; a dispensing needle having a gas passageway therein, in said dispensing head; and, a grill member movably mounted to conceal said needle and slidable to permit the same to pass therethrough.

2. The apparatus as claimed in claim 1 including spring means oriented to control sliding movement of said grill and finger means on said grill member oriented to releasably engage a disposable mouthpiece.

3. The apparatus as claimed in claim 1 including a dispensing arm swingably mounted in a vertical plane for supporting said dispensing head at varying heights.

4. Coin operated apparatus for dispensing gaseous oxygen and the like in predetermined unit volume and comprising: a high pressure vessel for storing said gas; a low-pressure vessel constituting a gas expansion chamber of predetermined unit volume connected to said pressure vessel; check valve means between said high and low pressure vessels; a dispensing head connected to said vessel and oriented to direct gas dispensed therefrom towards a purchaser; and, coin operated dispensing valve means between said low pressure vessel and said dispensing head.

5. The apparatus as claimed in claim 4 including pressure responsive coin operated check valve operating means operable to cause said check valve to check flow of gas from said high to said low pressure vessel upon a predetermined pressure being reached in said low pressure vessel.

6. The apparatus as claimed in claim 4 including time control means operable to control said dispensing valve and cut off flow from said low-pressure vessel after a predetermined time.

7. Coin operated apparatus for dispensing gaseous oxygen and the like in predetermined unit volume and comprising: a pressure vessel for storing said gas; an expansion chamber of predetermined unit volume connected to said pressure vessel; pressure responsive coin operated check valve means between said pressure vessel and said chamber operable to check flow of gas thereto upon a predetermined pressure being reached in said chamber; a dispensing head connected to said vessel and oriented to direct gas dispensed therefrom towards a purchaser; coin operated dispensing valve means between said chamber and said dispensing head; and time control means operable to control said dispensing valve and cut off flow from said chamber after a predetermined time and wherein said check valve, dispensing valve and time control means are electrically operated and are connected together in circuit.

8. The apparatus as claimed in claim 7 including manually operable control means responsive to a purchaser for checking flow of gas from said dispensing head.

9. Coin operated apparatus for dispensing gaseous oxygen and the like in predetermined unit volume and comprising: a pressure vessel for storing said gas; an expansion chamber of predetermined unit volume connected to said pressure vessel; coin operated dispensing valve means between said chamber and said dispensing head; a dis-

5

dispensing head connected to said vessel and oriented to direct gas dispensed therefrom towards a purchaser; a dispensing needle having a gas passageway therein, in said dispensing head; a grill member movably mounted to conceal said needle and slidable to permit the same to pass therethrough; and, dispensing control means responsive to movement of said grill to operate said dispensing valve.

10. The apparatus as claimed in claim 9 including one way flow control means between said chamber and said dispensing head.

6

References Cited by the Examiner

UNITED STATES PATENTS

2,855,926	10/1958	Koppelman.	
3,079,044	2/1963	Flynn -----	222—2
3,130,722	4/1964	Dempsey et al. -----	128—143
3,193,624	7/1965	Webb et al. -----	128—141 X
3,208,574	9/1965	Anson -----	194—3

ROBERT B. REEVES, *Primary Examiner.*

10 STANLEY H. TOLLBERG, *Examiner.*