

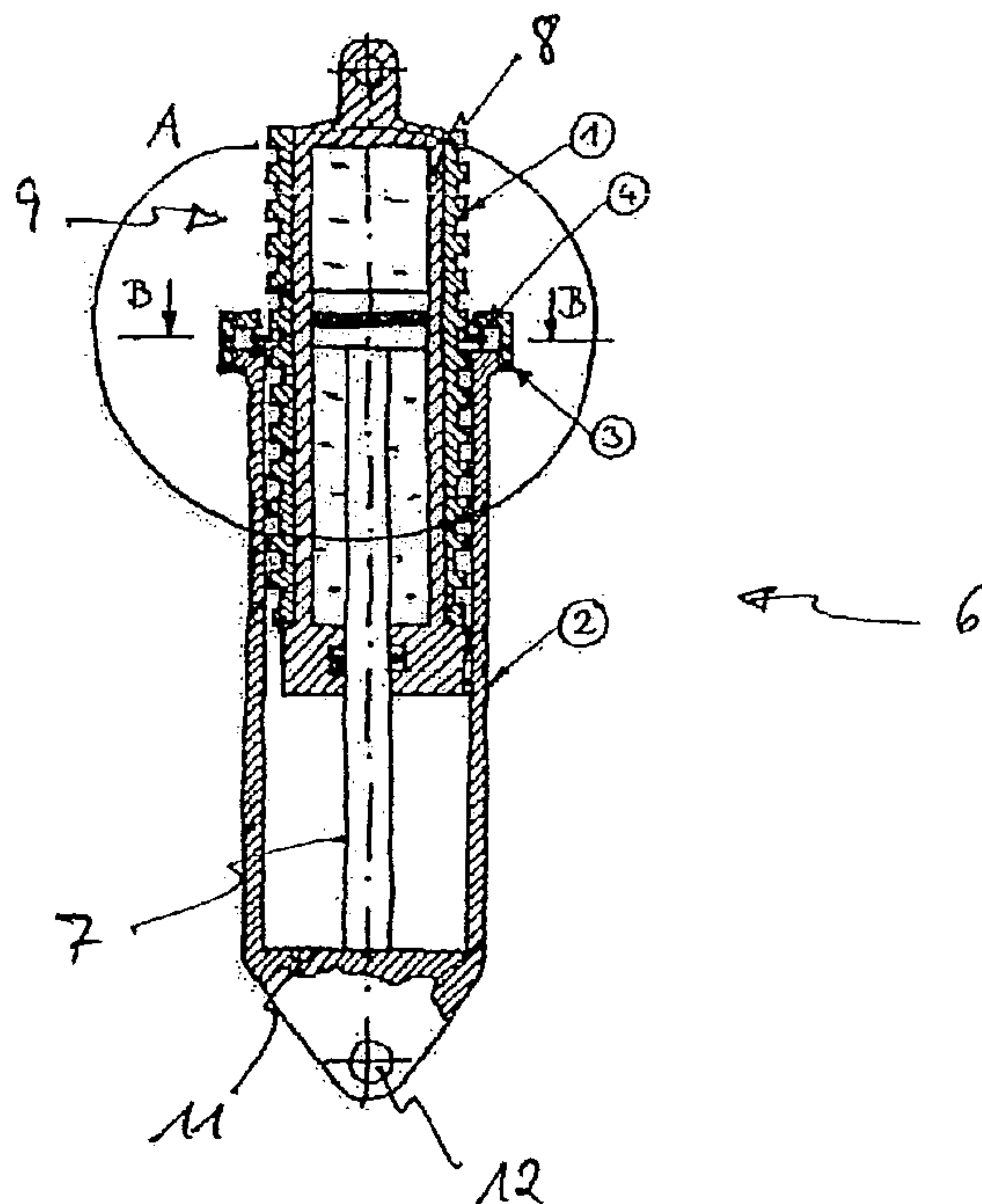

(86) Date de dépôt PCT/PCT Filing Date: 2006/08/31
 (87) Date publication PCT/PCT Publication Date: 2007/03/15
 (85) Entrée phase nationale/National Entry: 2008/02/05
 (86) N° demande PCT/PCT Application No.: EP 2006/008532
 (87) N° publication PCT/PCT Publication No.: 2007/028543
 (30) Priorités/Priorities: 2005/09/07 (DE60/714,807);
 2005/09/07 (DE10 2005 042 510.0)

(51) Cl.Int./Int.Cl. *F15B 15/26* (2006.01)
 (71) Demandeur/Applicant:
 AIRBUS DEUTSCHLAND GMBH, DE
 (72) Inventeur/Inventor:
 HAASE, GUNNAR, DE
 (74) Agent: BORDEN LADNER GERVAIS LLP

(54) Titre : VERROUILLAGE MECANIQUE EXTERIEUR POUR ACTIONNEUR LINEAIRE
 (54) Title: EXTERIOR MECHANICAL INTERLOCK FOR A LINEAR ACTUATOR



(57) **Abrégé/Abstract:**

The present invention relates to a locking mechanism, which permits to fix a piston rod (7) of a linear actuator (6) relatively to the cylinder (8) of the same (6). Furthermore, the invention relates to the usage of a linear actuator equipped with such a locking mechanism as well as to an aircraft with at least one linear activator that is equipped with the locking mechanism according to the present invention. The locking mechanism according to the present invention comprises a plurality of first positive locking elements (9) which are arranged lengthwise with the outside circumference of the cylinder (8) and in certain distances to one another and at least one second positive locking element (4), which is moved together with the piston rod (7) upon activation of the linear actuator (6) and thus passes a segment of the cylinder (8). The at least one second positive locking element (4) is positively engageable with one of the plurality of first locking elements (9) at discrete positions of the cylinder lengthwise, by which the piston rod (7) is fixed relatively to the cylinder (8).

(12) INTERNATIONAL APPLICATION PUBLISHED UNDER THE PATENT COOPERATION TREATY (PCT)

(19) World Intellectual Property Organization
International Bureau(43) International Publication Date
15 March 2007 (15.03.2007)

PCT

(10) International Publication Number
WO 2007/028543 A1(51) International Patent Classification:
F15B 15/26 (2006.01)

(21) International Application Number:

PCT/EP2006/008532

(22) International Filing Date: 31 August 2006 (31.08.2006)

(25) Filing Language: English

(26) Publication Language: English

(30) Priority Data:

10 2005 042 510.0

7 September 2005 (07.09.2005) DE

60/714,807 7 September 2005 (07.09.2005) DE

(71) Applicant (for all designated States except US): AIRBUS
DEUTSCHLAND GMBH [DE/DE]; Kreetslag 10, 21129
Hamburg (DE).

(72) Inventor; and

(75) Inventor/Applicant (for US only): HAASE, Gunnar
[DE/DE]; Schwartseekamp 13, 22880 Wedel (DE).(74) Agent: HAEUSLER, Rüdiger; Maiwald GmbH, Elisen-
hof, Elisenstr. 3, 80335 München (DE).(81) Designated States (unless otherwise indicated, for every
kind of national protection available): AE, AG, AL, AM,
AT, AU, AZ, BA, BB, BG, BR, BW, BY, BZ, CA, CH, CN,
CO, CR, CU, CZ, DE, DK, DM, DZ, EC, EE, EG, ES, FI,
GB, GD, GE, GH, GM, HN, HR, HU, ID, IL, IN, IS, JP,
KE, KG, KM, KN, KP, KR, KZ, LA, LC, LK, LR, LS, LT,
LU, LV, LY, MA, MD, MG, MK, MN, MW, MX, MY, MZ,
NA, NG, NI, NO, NZ, OM, PG, PH, PL, PT, RO, RS, RU,
SC, SD, SE, SG, SK, SL, SM, SV, SY, TJ, TM, TN, TR,
TT, TZ, UA, UG, US, UZ, VC, VN, ZA, ZM, ZW.(84) Designated States (unless otherwise indicated, for every
kind of regional protection available): ARIPO (BW, GH,
GM, KE, LS, MW, MZ, NA, SD, SL, SZ, TZ, UG, ZM,
ZW), Eurasian (AM, AZ, BY, KG, KZ, MD, RU, TJ, TM),
European (AT, BE, BG, CH, CY, CZ, DE, DK, EE, ES, FI,
FR, GB, GR, HU, IE, IS, IT, LT, LU, LV, MC, NL, PL, PT,
RO, SE, SI, SK, TR), OAPI (BF, BJ, CF, CG, CI, CM, GA,
GN, GQ, GW, ML, MR, NE, SN, TD, TG).

Published:

— with international search report

[Continued on next page]

(54) Title: EXTERIOR MECHANICAL INTERLOCK FOR A LINEAR ACTUATOR

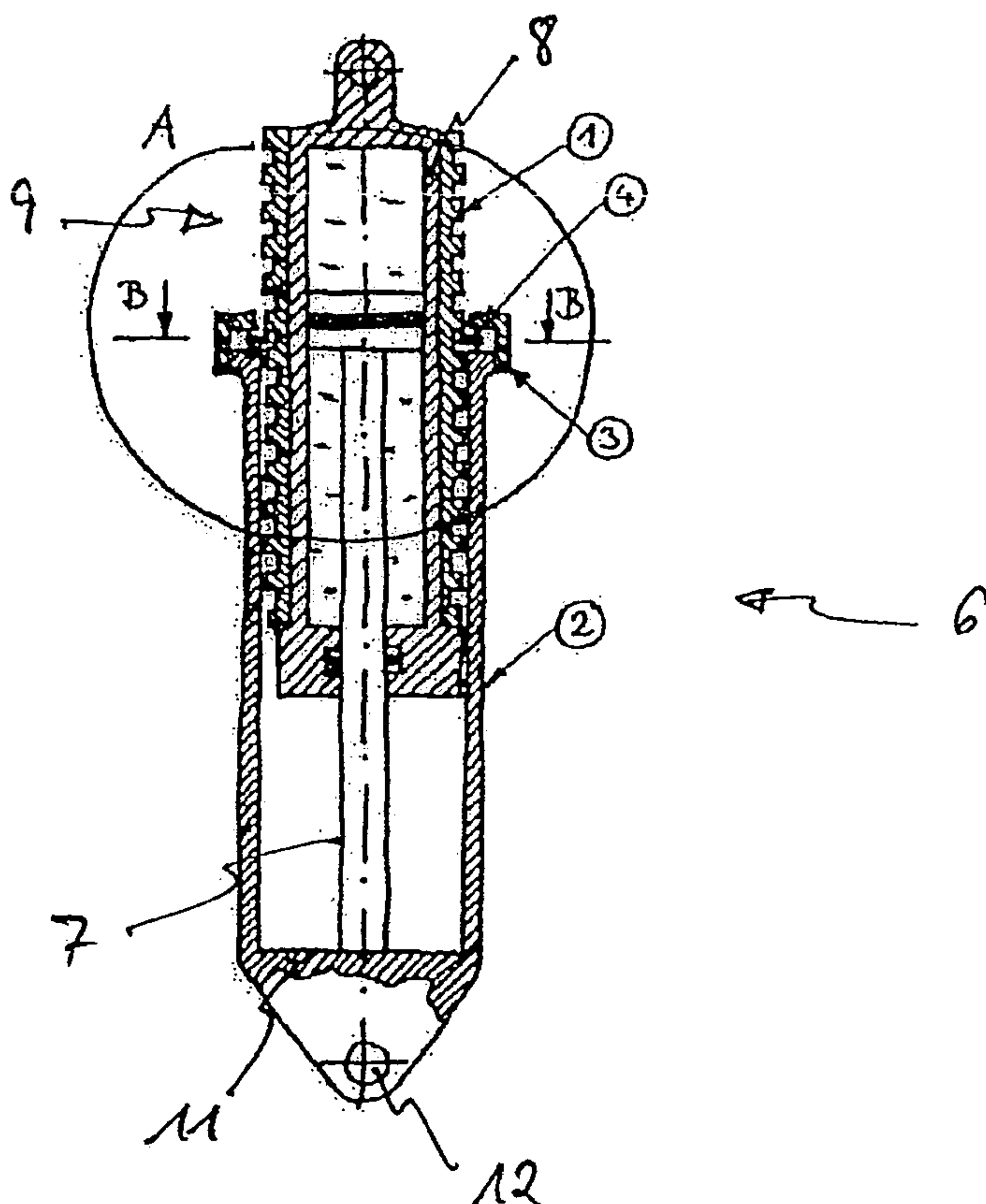

(57) Abstract: The present invention relates to a locking mechanism, which permits to fix a piston rod (7) of a linear actuator (6) relatively to the cylinder (8) of the same (6). Furthermore, the invention relates to the usage of a linear actuator equipped with such a locking mechanism as well as to an aircraft with at least one linear activator that is equipped with the locking mechanism according to the present invention. The locking mechanism according to the present invention comprises a plurality of first positive locking elements (9) which are arranged lengthwise with the outside circumference of the cylinder (8) and in certain distances to one another and at least one second positive locking element (4), which is moved together with the piston rod (7) upon activation of the linear actuator (6) and thus passes a segment of the cylinder (8). The at least one second positive locking element (4) is positively engageable with one of the plurality of first locking elements (9) at discrete positions of the cylinder lengthwise, by which the piston rod (7) is fixed relatively to the cylinder (8).

WO 2007/028543 A1

WO 2007/028543 A1



For two-letter codes and other abbreviations, refer to the "Guidance Notes on Codes and Abbreviations" appearing at the beginning of each regular issue of the PCT Gazette.

Exterior mechanical interlock for a linear actuator

This application claims the benefit of the filing date of United States Provisional
5 Patent Application No. 60/714,807 filed 07. September 2005 and of German Patent
Application No. 10 2005 042 510.0 filed 07. September 2005, the disclosures of
which are hereby incorporated herein by reference.

FIELD OF THE INVENTION

10

The present invention relates to a design layout of a piston cylinder unit in general.
In particular, the present invention relates to a locking mechanism with which the
piston rod of a linear actuator is fixed (festgelegt) relatively to the cylinder of the
same, thus to such a locking mechanism equipped linear actuator, with which the
15 horizontal stabilizer of an aircraft, like for example a horizontal tail, can be shifted in
its tilt in relation to the aircraft body. Ultimately the present invention relates to an
aircraft, which is equipped with such a linear actuator outfitted with a locking
mechanism according to the invention, with which the horizontal stabilizer of an
aircraft, like for example a horizontal tail, can be shifted in its tilt in relation to the
20 aircraft body.

TECHNOLOGICAL BACKGROUND

Usually aircraft tails which are trimmable in its tilt to the aircraft body, are trimmed
25 by the use of trapezoid thread spindles or ballscrews, that is to alter its tilt in relation
to the aircraft body. Such actuators used for alteration of the tilt of aircraft tails in
relation to the aircraft body are usually called "Trimmable Horizontal Stabilizer
Actuator" (short form: THSA) in the field of aerospace technology, which term will
be used in the present invention. To hold a load statically, trapezoid thread spindles
30 are constructed as self-locking and ballscrews as retarded.

Though it would be desirable to use pneumatic or hydraulic piston cylinder units as
Trimmable Horizontal Stabilizer Actuators, normally this is not possible due to the

- 2 -

fact that in case of a malfunction of the pressure feed of such a piston cylinder unit, the load can no longer be held in position. Though final position locking mechanisms like the so-called "Krüger Actuator" are known, such a final position locking mechanism is unable to fix the piston cylinder unit in an arbitrary position.

5 Furthermore there are different known techniques for holding a piston cylinder unit in an arbitrary position, however these systems, as a general rule, are based on a non-positive connection, which is carried out by a friction coupling in the interior of the cylinder, like in the case of the so called "Hähnchen Zylinder" by the company Hänchen.

10

With such a non-positive locking mechanism, only comparatively small static retention forces can be generated, which are considerably lower than the actuating power created by the piston cylinder unit itself. Thus, the known solutions for locking of a linear actuator can only securely lock the same in one defined position
15 or apply only minor retention forces (like for example with a non-positive locking mechanism).

Furthermore, the described known locking solutions are only poorly or not at all inspectable, as they are built into the interior of the piston cylinder unit. Due to the
20 aforementioned disadvantages, piston cylinder units cannot be considered as Trimmable Horizontal Stabilizer Actuators.

SUMMARY OF THE INVENTION

25 Starting from the aforementioned disadvantages, which prohibit the use of a piston cylinder unit as a Trimmable Horizontal Stabilizer Actuator, there may be a need to provide an implementation in which a linear actuator, like for example a piston cylinder unit, can be used reliably as a Trimmable Horizontal Stabilizer Actuator.

- 3 -

If in the context of the present invention it is spoken of a linear actuator, one has to subsume all piston cylinder units, which are driven for example by hydraulic, pneumatic or electrical energy, like for example generated by magnetic fields. In particular, linear actuators are to be understood as hydraulic or pneumatic cylinders.

5

The need may be met by a locking mechanism, with which the piston rod of a linear actuator can be fixed relatively (festgelegt) to the cylinder of the same, by the use of a linear actuator equipped with such a locking mechanism so that a horizontal stabilizer of an aircraft, like for example a horizontal tail, may be adjusted in its tilt in relation to the aircraft body and by an aircraft which is equipped with a linear actuator with such a locking mechanism according to an exemplary embodiment, so that a horizontal stabilizer of an aircraft, like for example a horizontal tail, may be adjusted in its tilt in relation to the aircraft body.

10

15 According to a first embodiment, the locking mechanism according to the present invention is able to fix the piston rod of a linear actuator relatively to the cylinder of the same. The locking mechanism according to the first embodiment comprises a plurality of first positive locking elements which are arranged lengthwisely on the outside circumference of the cylinder and have a predetermined spacing to each other. The locking mechanism further comprises at least one second positive locking element which moves together with the piston rod when the linear actuator is activated, and passes a portion of the cylinder. The simultaneous movement of the second positive locking element with the piston rod may be achieved by at least indirectly connecting the second positive locking element to the piston rod. To fix the piston rod relatively to the cylinder the at least one second positive locking element is formed to engage with one of the plurality of first positive locking elements at one discrete position of the cylinder lengthwisely. Due to the aforementioned fact that the second positive locking element is at least indirectly connected to the piston rod, further operating of the linear actuator may be prevented due to the attained positive locking, so that in case of a malfunction of the energy

20

25

30

- 4 -

supply to the linear actuator the last set position of the linear actuator may be upheld by using the locking element according to the present invention.

Alternatively to this first embodiment, it may also be possible to reverse the
5 relationship. In this case the locking element comprises, according to an alternative second embodiment, at least one first positive locking element, which is arranged on the outside circumference of the cylinder in the area of the exit of the piston rod. The locking mechanism further comprises a plurality of second locking elements which are moving together with the piston rod when the linear actuator is operated, thus
10 passing the first positive locking element.

The simultaneous movement of the second positive locking elements together with the piston rod may be achieved by at least indirectly connecting the second positive locking elements to the piston rod. To fix the piston rod relatively to the cylinder the
15 at least one first positive locking element is constructed to engage positively with one of the plurality of second positive locking elements. Due to the aforementioned fact that the second positive locking elements are at least indirectly connected to the piston rod, further operation of the linear actuator may be prevented, due to the attained positive locking, so that in case of a malfunction of the energy supply to the
20 linear actuator the last set position of the linear actuator may be upheld by using the locking element according to the present invention.

The described mechanical locking element is usable with all kinds of linear actuators, for example hydraulic or pneumatic cylinders or electrically charged piston cylinder
25 units, which have a cylindrical shape and which are to be mechanically locked securely in certain discrete positions. Though a starting point for the present invention may be to provide a realization for a Trimmable Horizontal Stabilizer Actuator which possibly permits to use a piston cylinder unit as Trimmable Horizontal Stabilizer Actuator, the locking mechanism according to the present
30 invention may of course be used for other flight control actuators like for example

- 5 -

actuators for flaps, slats or spoilers. Furthermore, the locking mechanism according to the present invention may be used for other aviation related applications like for example door actuators.

5 With the development of the locking mechanism according to the present invention linear actuators (electrical, hydraulic, or pneumatic) may be used in a completely new area of application, enabling the use of piston cylinder units as Trimmable Horizontal Stabilizer Actuators. Due to the mechanical locking mechanism the linear actuator may be capable of securely holding the last set position in case of a
10 malfunction of the power input, for that it may not need any additional energy, which will be described in greater detail in the following. Unlike the known non-positive locking mechanisms, a linear actuator equipped with a locking mechanism according to the present invention having adequate dimensioning of the locking mechanism, may be able to securely hold loads in the order of magnitude of the actuating power
15 generated by the linear actuator itself.

Since the locking mechanism according to the present invention is predominantly located on the outside circumference of the linear actuator and/or its cylinder, the locking mechanism may be examined, maintained, tested and, if necessary, easily
20 repaired. Since the locking mechanism itself, in the case of a malfunction in the power input to the linear actuator, transfers forces from the cylinder to the piston rod, it may constitute a second load path, through which in case of a power failure the load of the linear actuator may be transferred safely.

25 Below, special embodiments of the firstly described first embodiment of the locking mechanism according to the present invention will be explained. These special embodiments can self-evidently be used, with minor adaptations, in a similar way on the aforementioned second embodiment of the locking mechanism according to the present invention.

30

- 6 -

In order to positively lock the at least one second positive locking element with one of the plurality of first positive locking elements, the at least one second positive locking element is designed in a way to either be able to take a locked or alternatively an unlocked position. In the locked position, the at least one second positive locking element is engaged with one of the plurality of first positive locking elements, whereas in the open position the positive locking is suspended.

In order to not have to supply additional energy to move the at least one second positive locking element to its locked state, the at least one second locking element is designed so that it creates a reset force which always tries to move it from the unlocked position to the locked position. To counteract this reset force, so that the at least one second positive locking element does not move to its locked position at arbitrary points in time, the locking mechanism according to the present invention additionally comprises an unlocking actuator, which is designed and arranged in such a way that with its activation the at least one second positive locking element is held in its unlocked position counteracting the reset force.

Like suggested before, no additional energy may be needed in order to activate the locking mechanism in case of a failure of the power input. This may be realized in a way in which the activation of the unlocking actuator is carried out by an energy input that is coupled with the one by which the linear actuator is operated, which may implicate that in case of a failure of the power input of the linear actuator the at least one second positive locking element, due to its reset force, may move to its locked position. In the case of, for example, a hydraulically operated linear actuator, an also hydraulically operated unlocking actuator can be used, wherein the admission of both actuators is coupled in such a way that with the failure of the main energy input of the linear actuator the energy input of the unlocking actuator fails as well, resulting in the at least one second locking element automatically moving to its locked position at the time of the energy failure thus arresting the last set position of the linear actuator.

- 7 -

One concrete design of the plurality of first positive locking elements can be realized, for example, by a plurality of grooves, which surround the cylinder on its external peripheral side. Here, the plurality of grooves can be integrally worked into the external peripheral side of the cylinder or built onto a separate tube jointing sleeve (Rohrhülse), which inside diameter is matched to the external diameter of the cylinder in such a way that the tube jointing sleeve can be attached onto the latter.

Like explained before, the at least one second positive locking element is attached indirectly to the piston rod to be able to move together with it. This indirect connection can, for example, be accomplished by a dip pipe (Tauchrohr), which is connected to an end of the piston rod that is situated outside of the cylinder and which concentrically surrounds the piston rod in a certain distance. This distance is dimensioned in such a way that, while operating the linear actuator, the cylinder may immerse into this certain distance. In order to fix the dip pipe and thus the piston rod relatively to the cylinder, in the area where the dip pipe and the cylinder overlap, the dip pipe is accepting the at least one second positive locking element. The connection between the dip pipe and the open end of the piston rod can be realized in such a way that the dip pipe on one end exhibits a closed front wall at which said open end of the piston rod can be attached to the inside of the dip pipe, so that in combination they form some sort of jacket (Glocke).

A simple design of the at least one second positive locking mechanism can be realized in such a way that this positive locking mechanism is designed as a spring washer clamp (Federringklemme), which is dimensioned in such a way that in its locked position it is positively locked with one of the plurality of grooves.

Alternatively, it would be possible as well to provide the second locking mechanism as multiple small piston cylinder units, which are, for example, arranged on the outside of the cylinder and which piston rods, driven by a spring force, engage with the grooves of the cylinder in case of an energy failure.

- 8 -

For the incorporation of a second positive locking element, which is designed as a spring washer clamp, within the dip pipe, it is possible to form an annular gap in the area where the cylinder and the locking mechanism overlap, which accommodates
5 the spring washer clamp in its unlocked position.

According to a further aspect of the present invention, it is intended to use a linear actuator having a previously described locking mechanism as a Trimmable Horizontal Stabilizer Actuator. Such a usage of linear actuators was not possible until
10 now, due to the fact that known interlock mechanisms for linear actuators could only impose minor retention forces or were even unable to be locked in arbitrary positions.

According to a further aspect of the present invention, an aircraft with at least one
15 linear actuator, having a locking mechanism that exhibits some of the aforementioned features, is provided.

BRIEF DESCRIPTION OF THE DRAWINGS

20 Below the present invention is explained further in reference to the attached drawings, which only represent an exemplary embodiment of the invention. It shows:

Fig. 1 is an exploded view of a locking mechanism according to an exemplary embodiment of the present invention;

25

Fig. 2a shows a longitudinal section through a piston cylinder unit equipped with a locking mechanism according to an exemplary embodiment of the present invention;

30 Fig. 2b shows detail A of Fig. 2a in an enlarged illustration; and

- 9 -

Fig. 3 shows a cross-section of the locking mechanism according to an exemplary embodiment of the present invention along line B-B of Fig. 2a.

5

In all figures, identical or corresponding elements are identified with identical or corresponding reference signs. The figures are not drawn to scale, however they can depict qualitative proportions.

10 DESCRIPTION OF AN EXEMPLARY EMBODIMENT

Below, the locking mechanism according to the present invention is described exemplarily by a hydraulic linear actuator 6, though the functional principle of the present invention can be transferred accordingly to a pneumatically or by any other
15 means operated linear actuator with cylindrical structural shape.

Below, the invention is explained in detail in reference to the included drawings, wherein all four figures 1 – 3 are referred to in equal measure. The locking mechanism according to an exemplary embodiment of the present invention is used
20 to fix a piston rod 7 of a linear actuator 6 in relation to its cylinder 8. Such a linear actuator 6 designed as a hydraulic piston cylinder unit 6 is easily recognizable in Fig. 2a. Here, the hydraulic piston cylinder unit 6 mainly includes a cylinder 8 and a piston rod 7, which is seated lengthwisely relocateable in cylinder 8. By pressurizing the hollow space of cylinder 8, the piston rod 7 is moved lengthwisely in well-known
25 manner. As can be seen in Fig. 2a and especially well in Fig. 2b, a tube jointing sleeve is attached to the exterior circumference of cylinder 8, for example by clamping, which tube jointing sleeve comprises of a plurality of grooves 9 on the side of the external circumference, which are arranged lengthwisely on the cylinder with a certain distance between them. Though in the example shown, the grooves 9
30 are designed to be on a separate tube jointing sleeve, it is self-evident that the

- 10 -

grooves 9 can be incorporated directly into the outer circumference of the cylinder 8 as well.

As is additionally shown in Fig. 2b , the piston rod 7 is concentrically surrounded by a so-called dip pipe 2, which is attached to the piston rod 7 at its open end. The dip pipe 2 surrounds the piston rod 7 in such a distance that the cylinder 8 can immerse into this distance when the piston cylinder unit 6 is activated.

The piston rod 7 is connected to the dip pipe 2 via a front wall 11, which seals the dip pipe 2 at one end and in which continuation a lug 12 is designed for linkage of the piston cylinder unit 6.

At the end of the dip pipe 2 sealed front wall 11, the active locking unit is arranged in form of the at least one second locking element 4.

15

As can be seen best in Fig. 1 and 3, the at least one second positive locking mechanism is designed in the shown exemplary embodiment as a spring washer clamp 4, which is accommodated in its unlocked position by an annular gap 10, that is formed at the open end of dip pipe 2. This annular gap 10 can, for example, be formed by a rosette bracket 3, which can, for example, be screwed onto a widening at the end of the dip pipe 2. The inner diameter of the spring washer clamp 4 is dimensioned in such a way that in unstretched condition, thus its locking position, it substantially equals the inner diameter of the grooves of the tube jointing sleeve 1.

25 In order not to lock the piston cylinder unit having the locking mechanism according to the present invention permanently, a small unlocking actuator 5 is provided at the open ends of the spring washer clamp 4, which unlocking actuator is coupled with a power source, which again is coupled with the one, that is operating the piston cylinder unit 6 itself. By activating the unlocking activator 5 , the spring washer clamp 4 is held, against its own reset force, which always tries to move it to its

30

- 11 -

locked position, in unlocked position, in which the spring washer clamp 4 is accommodated by the annular gap 10, so that a free operation of the piston cylinder unit 6 is achieved.

- 5 In case that the power source to piston cylinder unit 6 is failing at a point in time, the unlocking actuator can no longer compensate the reset force of spring washer clamp 4, due to the coupling between the power input to the unlocking actuator 5 and the power input of the piston cylinder unit 6, leading to the fact that the spring washer clamp 4 moves from its unlocked position to its locked position, in which it engages
- 10 with one of the grooves 9 of the tube jointing sleeve 1, so that the piston rod 7 is fixed relatively to the cylinder 8. The correspondingly achieved positive locking connection between the two lugs 12 of the piston cylinder unit 6 securely locks the cylinder and presents a second load path for additional safety.
- 15 In addition it should be mentioned that “comprising” and “including” does not exclude other elements or steps, and “a” or “one” does not exclude a plural number. Furthermore, it should be mentioned that features or steps which have been described with reference to one of the above embodiments can also be used in combination
- 20 with other features or steps of other embodiments described above. Reference signs in the claims are not to be interpreted as limitations.

LIST OF REFERENCE FIGURES

	1	tube jointing sleeve
	2	dip pipe
5	3	rosette bracket (Halterosette)
	4	spring washer clamp
	5	unlocking actuator
	6	linear actuator
	7	piston rod
10	8	cylinder
	9	grooves
	10	annular gap
	11	front wall
	12	lug
15		

CLAIMS

1. Locking mechanism for fixing a linear actuator comprising a piston rod (7) and a cylinder (8), the locking mechanism comprising:
 - 5 - a plurality of first positive locking elements (9) which are arranged lengthwisely on the outside circumference of the cylinder (8) and in certain distances to one another, and
 - at least one second positive locking element (4), which moves together with the piston rod (7) when the linear actuator (6) is activated, and
10 thereby passes a segment of the cylinder,
wherein the at least one second positive locking element (4) is positively engageable with one of the plurality of first locking elements at discrete positions of the cylinder in lengthwise direction, so that the piston rod (7) is fixed relatively to the cylinder (8).
- 15 2. The locking mechanism of claim 1,
wherein the at least one second positive locking element (4) is adapted in such a way, to either take a locked position, in which it is engaged with one of the plurality of first positive locking elements (9) to form a positive locking, or
20 alternatively take an unlocked position, in which the positive locking is suspended.
3. The locking mechanism of claim 2,
wherein the at least one second positive locking element (4) is adapted in
25 such a way, as to create a reset force, which tries to move it from the unlocked position to the locked position.
4. The locking mechanism of claim 3, further comprising:

- 14 -

- an unlocking actuator (5), by which activation the at least one second positive locking element (4) will be held in its unlocked position counteracting the reset force.

- 5 5. The locking mechanism of claim 4,
 wherein the activation of the unlocking actuator (5) is performed using a
 power input, which is coupled with that one, that is operating the linear
 actuator (6), so that in case of a failure of the power input of the linear
 actuator (6) the at least one second positive locking element (4), is moving to
10 the locked position, due to the reset force.
6. The locking mechanism according to one of the preceding claims,
 wherein the plurality of first positive locking mechanisms (9) is formed by a
 plurality of grooves (9), which surround the cylinder (8) on its exterior
15 circumferential side.
7. The locking mechanism of claim 6,
 wherein the plurality of grooves (9) are integrally formed in the exterior
 circumference of the cylinder (8).
20
8. The locking mechanism of claim 6,
 wherein the plurality of grooves (9) are formed in a separate tube jointing
 sleeve (1), the inside diameter of which is matched to the outside diameter of
 the cylinder (8) in such a way that the tube jointing sleeve (1) is attachable to
25 the same.
9. The locking mechanism according to one of the preceding claims, further
 comprising:

- 15 -

- a dip pipe (2), which is attached to an end of the piston rod, which end is outside of the cylinder (8) and which concentrically surrounds the piston rod (7) spaced apart by a certain separation distance, wherein the distance is dimensioned in such a way, that upon activation of the linear actuator (6) the cylinder (8) is immersed in the separation distance, and
5 wherein the dip pipe (2), in the area where it overlaps with the cylinder (8), is accepting in its inner wall the at least one second positive locking (4) element.
- 10 10. The locking mechanism of claim 9, wherein the dip pipe (2) comprises a closed front wall (11) at one end, by which the piston rod (7) is at least indirectly connected to the dip pipe (2).
- 11. The locking mechanism according to one of the claims 6 to 10,
15 wherein the at least one second positive locking element (4) is adapted as a spring washer clamp (4), which is positively engaging one of the plurality of grooves (9) when in its locked position.
- 12. The locking mechanism of claim 11,
20 wherein the dip pipe (2), in the area where it is overlapping with the cylinder (8), forms an annular gap (10), in which the spring washer clamp (4) is accepted.
- 13. Locking mechanism for fixing a linear actuator comprising a piston rod and a
25 cylinder, the locking mechanism comprising:
 - at least one first positive locking element, which is arranged on the outside circumference of the cylinder in the area of the exit of the piston rod, and

- 16 -

- a plurality of second positive locking elements, which move together with the piston rod, when activating the linear actuator, and thereby passing the first locking element,

wherein the at least one first positive locking element is positively engageable with one of the plurality of second positive locking elements at discrete positions of the piston rod in lengthwise direction, so that the piston rod is fixed relatively to the cylinder.

- 5
14. The locking mechanism of claim 13,
10 wherein the at least one first positive locking element is adapted in such a way to either take a locked position, in which it is engaged with one of the plurality of second locking elements to form a positive locking, or to alternatively take an unlocked position, in which the positive locking is suspended.

- 15
15. The locking mechanism of claim 14,
wherein the at least one first positive locking element is adapted in such a way, as to create a reset force, which tries to move it from the unlocked position to the locked position.

- 20
16. The locking mechanism of claim 15, further comprising:
- an unlocking actuator, by which activation the at least one first positive locking element is held in its unlocked position counteracting the reset force.

- 25
17. The locking mechanism of claim 16,
wherein the activation of the unlocking actuator is performed using a power input, which is coupled with that one, that is operating the linear actuator, so that in case of a failure in the power input of the linear actuator the at least

- 17 -

one second positive locking element is moved to the locked position due to the reset force.

18. The locking mechanism according to one of the claims 13 to 17, further
5 comprising:
- a dip pipe, which is attached to an end of the piston rod, which end is outside of the cylinder situated and which concentrically surrounds the piston rod spaced apart by a certain separation distance, wherein the distance is dimensioned in such a way, that upon activation of the
10 linear actuator the cylinder is immersed in the separation distance.
19. The locking mechanism according to one of the claims 13 to 18, wherein the plurality of second positive locking elements is formed by a plurality of grooves which are incorporated into the inner circumference of
15 the dip pipe.
20. The locking mechanism according to claim 18 or 19, wherein the dip pipe comprises a closed front wall at one end, by which the piston rod is at least indirectly connected to the dip pipe.
20
21. The locking mechanism according to claim 19 or 20, wherein the at least one first positive locking element is formed as a spring washer clamp, which is positively engaging with one of the plurality of grooves when in its locked position.
25
22. The locking mechanism according to one of the claims 18 to 21, wherein the cylinder, in the area where it is overlapping with the dip pipe, forms an annular gap, in which the spring washer clamp is accepted.

- 18 -

23. Usage of a linear actuator (6) equipped with a locking mechanism as Trimmable Horizontal Stabilizer Actuator, which locking mechanism is formed according to one of the claims 1 to 22.
- 5 24. Aircraft with at least one linear actuator (6) for trimming an aircraft fin, wherein the at least one linear actuator is equipped with a locking mechanism, which is formed according to one of the claims 1 to 22.

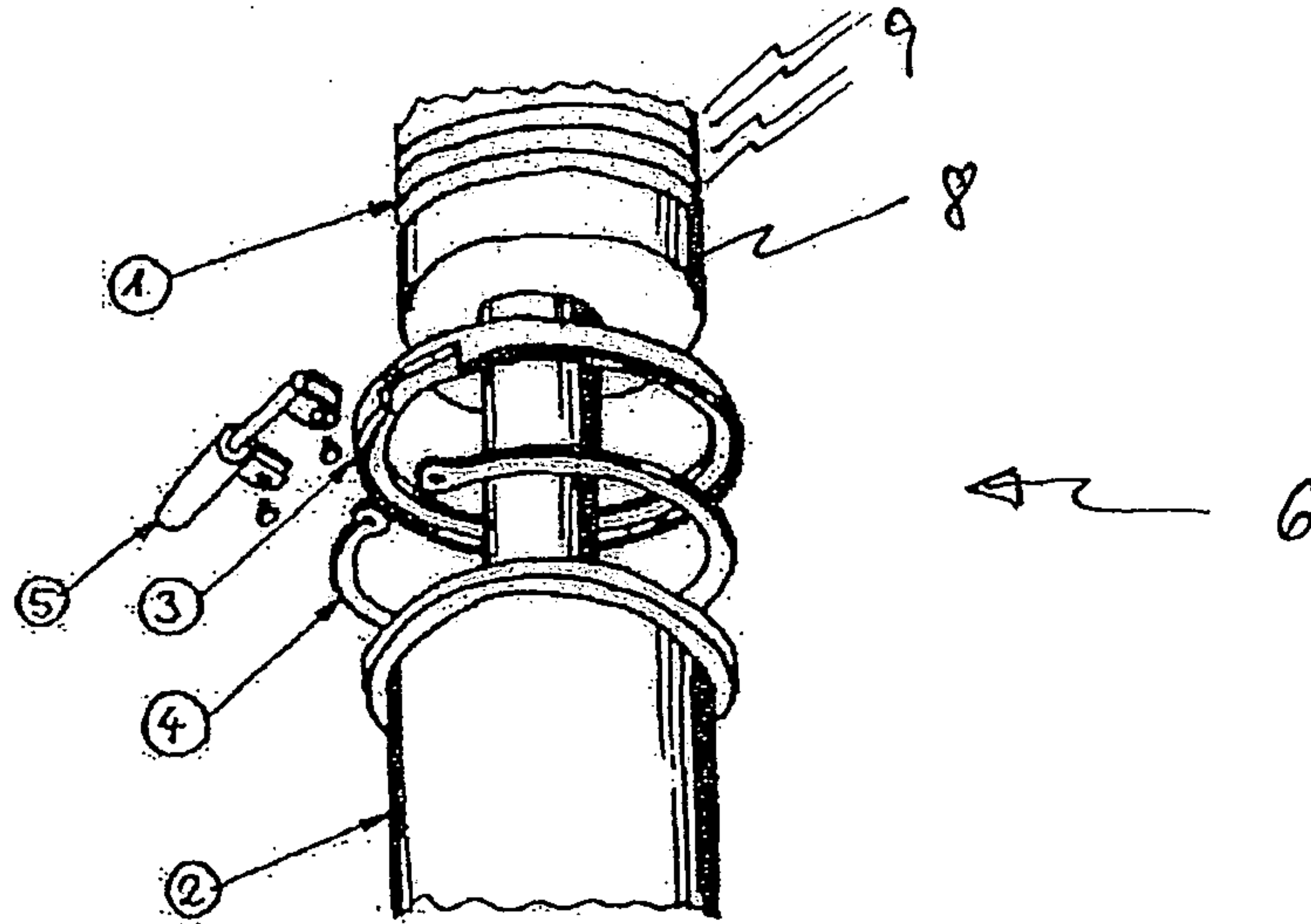

Fig. 1

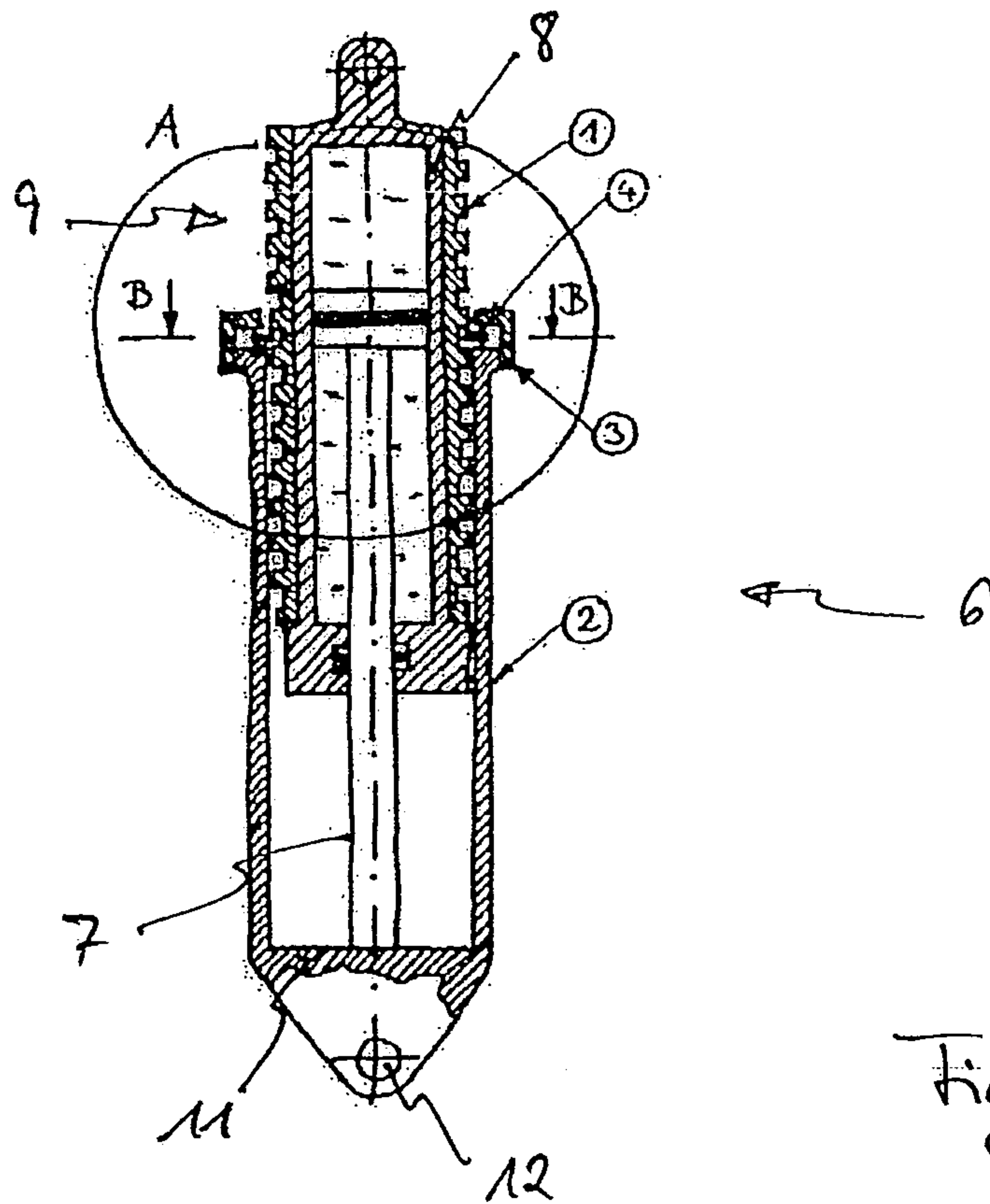

Fig. 2a

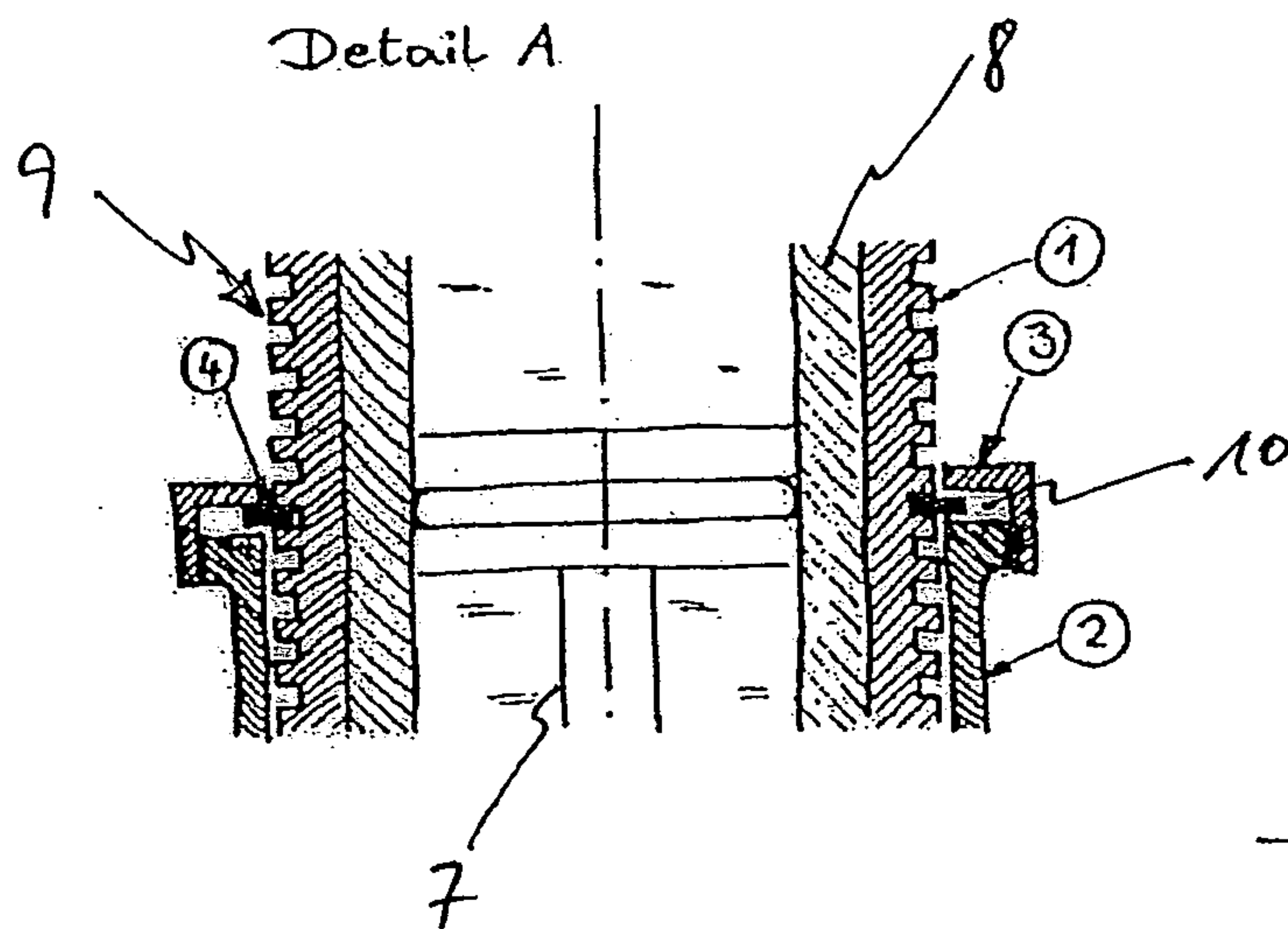

Fig. 2b

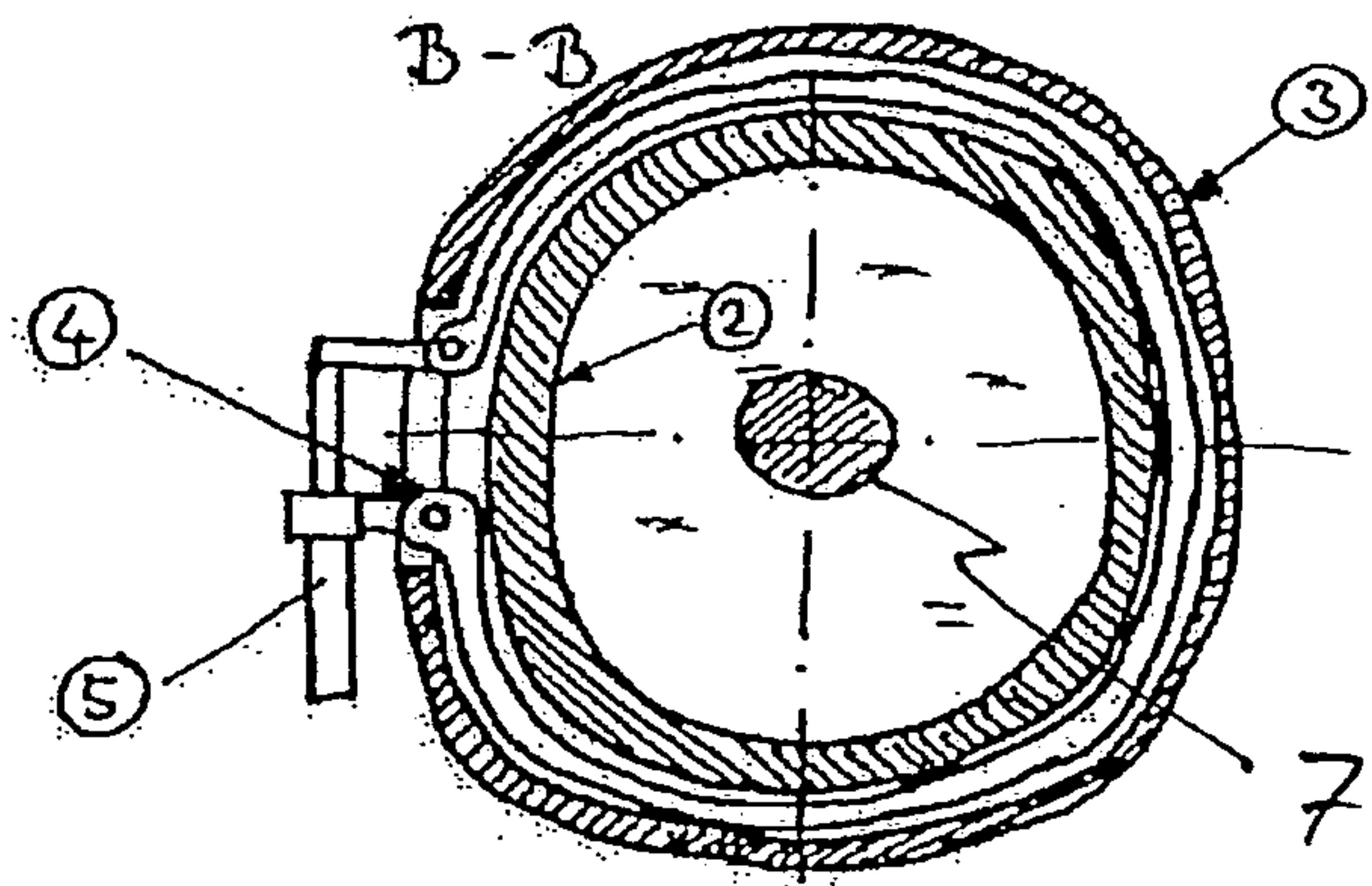

Fig. 3

