

(19)



(11)

**EP 2 762 670 A2**

(12)

**EUROPEAN PATENT APPLICATION**

(43) Date of publication:  
**06.08.2014 Bulletin 2014/32**

(51) Int Cl.:  
**E06B 7/04 (2006.01)**      **E04D 13/03 (2006.01)**  
**F24F 13/18 (2006.01)**

(21) Application number: **14153579.9**

(22) Date of filing: **03.02.2014**

(84) Designated Contracting States:  
**AL AT BE BG CH CY CZ DE DK EE ES FI FR GB GR HR HU IE IS IT LI LT LU LV MC MK MT NL NO PL PT RO RS SE SI SK SM TR**  
Designated Extension States:  
**BA ME**

(71) Applicant: **FAKRO PP Spolka z o.o.**  
**33-300 Nowy Sacz (PL)**

(72) Inventors:  
• **Majoch, Wac aw**  
**33-300 Nowy Sacz (PL)**  
• **Musia , Henryk**  
**32-020 Wieliczka (PL)**

(30) Priority: **04.02.2013 PL 40264413**

(54) **Window system with an air outlet**

(57) A window system consisting basically of windows with standard manufacturer's sizes and air outlets being separate elements, optionally installed beside the external surface of the frame top member (21) or beside the external surface of the frame bottom member (23) or beside the external surface of one of the frame side mem-

bers (22), and a flashing set (4), sealing the connection of the windows and the air outlets with the roof decking, consisting of a top flashing (41), a bottom flashing (42), side channels (34) and an additional element - a connector (44), sealing the connection of the system window with the air outlet.

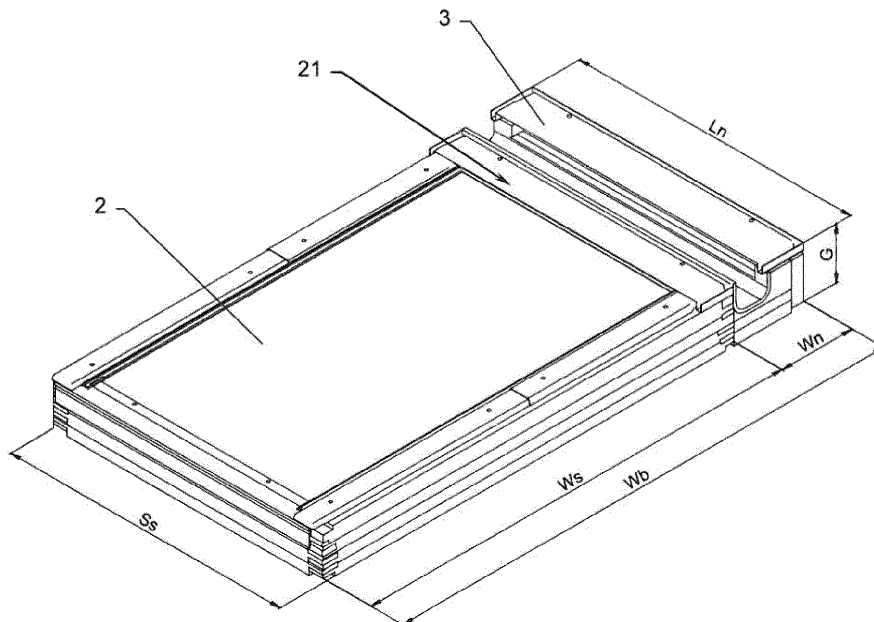

Fig. 2

**EP 2 762 670 A2**

## Description

**[0001]** The present invention relates to a window system with an air outlet, the system consisting of multiple windows, particularly roof windows, each window having dimensions corresponding to a predefined size belonging to standard size series offered by a manufacturer.

**[0002]** The air outlet functions basically as a duct conveying fresh air to rooms. In general, air outlets are used in exterior wall windows, however in case of attics, where most often roof windows are the only windows, a need for air outlets built-in into the structure of the roof window has arisen. Air outlets installed in the window structure are a natural solution, because of relative ease of their manufacturing and installation. In this case, making additional air outlet openings in the exterior wall or in the roof is not necessary.

**[0003]** One of the many known examples of solutions for air outlets built-in into the structure of the window frame is shown in Patent Application No. WO 2008/133539 A2. A solution for an automatic pressure-controlled opening or closing method of the air supply duct is disclosed in this application. However, solutions of such a type force significant enlargement of the window frame dimensions in order to integrate the air supply duct. In case of the described solution, the window frame width had to be significantly enlarged.

**[0004]** An example of the air outlet built-in into the frame of a casement is shown in Patent Application No. WO 03/001017 A1. The main element of this solution is a circular rotary ventilation valve installed in an opening made in the installation strip being a part of the top casement frame. In the closed position of the casement, the air duct is formed by the said ventilation valve and the space defined by the walls of the casement frame from one side and by the window frame walls from the other side. A disadvantage of this solution consists in a significant reduction of the window clearance accompanied by a small size of the ventilation duct. The rest of the installation strip is not used. Moreover, this solution is hard to use in roof windows because of a lack of protection from weather conditions. A similar idea is constituted by an air outlet proposed in Patent Application No. WO 2005038165 A1. A ventilation opening in the installation strip being a part of the window casement is closed by a flap valve, and the air supply duct is profiled in a way preventing penetration of water from the typical direction of precipitation. This solution is suitable both for exterior wall windows and roof windows.

**[0005]** All solutions for air outlets known in the market, including the ones cited above, utilise window casement frame or window frame for realization of the air supply duct and installation of elements of the air outlet. There are also many solutions utilising ducts formed between the window frame and the casement frame in the closed position. Their common disadvantage consists in a necessity to modify the structure of the profile of the window casement and window frame, which is most often unfavourable because of hindered profile forming and reduction of its mechanical strength, as well as increase in heat losses.

vourable because of hindered profile forming and reduction of its mechanical strength, as well as increase in heat losses.

**[0006]** From Patent No. EP 1656484 B1, a window system is known which contains at least one window of predefined size, containing partially components of a window with one size, and partially one or more components of a window of another type in the given size range. This solution allows for installing, e.g. two different windows with standard sizes jointly in one window opening with dimensions included in the dimensional range of the window system.

**[0007]** The solution proposed according to the invention introduces a possibility to install the window and the air outlet in a window system with various sizes, without any interference into the window structure.

**[0008] The distinguishing feature of the invention** consists in a window system basically composed of windows with standard manufacturer's sizes, and air outlets being separate elements, installed optionally beside the window. An air outlet, installed beside the external surface of the window frame, intended basically for mounting on the reveal of the window opening, has the shape and external dimensions chosen in a way enabling its application in the said window system. The set composed of air outlets and multiple windows with interrelated sizes forms the window system, which enables the user to choose from a series of solutions with regard both to functions and sizes.

**[0009]** The size of a rectangular windows is basically defined by two dimensions - width  $S$  and height  $W$ , most often reported in the form of  $S \times W$  product. Moreover, depth  $G$  is also an important dimension. It is preferably the same or close for all windows and air outlets in the window system.

**[0010]** Basically, one air outlet is installed in the set, however the system allows for installing a higher number of air outlets side by side, if need be. There is also a possibility to install interchangeably in the same window opening, a base window without the air outlet (with standard dimensions from the manufacturer's dimensional series), as well as a set in the form of the air outlet and a smaller system window from the same manufacturer's dimensional series, maintaining total external dimensions preferably equal to dimensions of the base window without the air outlet.

**[0011]** In the solution according to the invention, three main cases are proposed, differing in the place of installation of the air outlets. The first case comprises a solution with an air outlet installed beside the external surface of the frame top member. The second case comprises a solution with an air outlet installed beside the external surface of the frame bottom member. The third case comprises a solution with an air outlet installed beside the external surface of one of the frame side members.

**[0012] In the first case**, wherein the top air outlet is mounted beside the frame top member, its total length  $L_n$  is preferably equal to width  $S_b$  of the base window.

Width  $S_s$  of the system window is preferably equal to width  $S_b$  of the base window. Depth  $G$  of the top air outlet may be defined freely within the framework of the selected sheet metal flashing of the window, however preferably it is equal to the depth  $G$  of the system window. Height  $W_n$  of the top air outlet is an element of the proposed window system and this dimension is preferably a difference between the height  $W_b$  of the base window from the manufacturer's dimensional series and the height  $W_s$  of the next system window with smaller height from the same dimensional series.

**[0013]** In the second case, wherein the bottom air outlet is mounted beside the frame bottom member, its total length  $L_n$  is preferably equal to width  $S_b$  of the base window. Width  $S_s$  of the system window is preferably equal to width  $S_b$  of the base window. Apart from the place of installation and minor differences in the shape of the sheet metal flashing, this case is similar to the first case, i.e. depth  $G$  of the air outlet is preferably equal to depth  $G$  of the system window, and its height  $W_n$  is preferably a difference between the height  $W_b$  of the base window from the manufacturer's dimensional series and the height  $W_s$  of the system window from the same dimensional series, with smaller height.

**[0014]** In the third case the side air outlet is mounted beside the frame side member and its total length  $L_n$  is preferably equal to the height  $W_s$  of the system window. Height  $W_s$  of the system window is preferably equal to the height  $W_b$  of the base window. Depth  $G$  of the side air outlet may be defined freely within the framework of the selected sheet metal flashing of the window, however is preferably equal or close to the depth  $G$  of the system window. Height  $W_n$  of the side air outlet is an element of the proposed window system and this dimension is preferably a difference between the width  $S_b$  of the base window from the manufacturer's dimensional series and the width  $S_s$  of the system window from the same dimensional series, with smaller width.

**[0015]** Within the framework of the proposed window system, installation of a higher number of air outlets in one window opening is also possible.

**[0016]** For example, one of possible configurations comprises a system window with the next smaller height dimension  $W_s$  in relation to system windows according to cases 1 and 2, and at least two air outlets - top or bottom - mounted beside the frame top member or the frame bottom member. The air outlets may be mounted as opposite, i.e. the top air outlet beside the frame top member and the bottom air outlet beside the frame bottom member. They may be mounted also from one side of the system window, wherein one air outlet is mounted beside the frame top member or the frame bottom member, and the other one is mounted beside the first one. Such a set also meets the requirements of a window set, meaning that the total height of the system window  $W_s$  and heights  $W_n$  of the air outlets while assembled correspond basically to the height  $W_b$  of the base window.

**[0017]** A similar configuration may be assembled in the

case of mounting of two or more side air outlets beside the frame side members. They may be one mounted on the opposite frame side members, or on one side of the system window side by side. In this case, also total width  $S_s$  of the system window, with correspondingly smaller dimension within the dimensional series, and height  $W_n$  of the air outlets, while assembled, basically corresponds to the width  $S_b$  of the base window.

**[0018]** In the above description installation allowances and working tolerances have been omitted, while they should be taken under consideration during production of windows with an air outlet according to the invention. In general, difference in size of the base window and the system window with at least one air outlet is preferably equal to zero, however considering installation allowances and working tolerances, it should not exceed 5%, and the individual system dimensions should not exceed tolerance of several millimetres.

**[0019]** The window system according to the invention has a multi-element set of flashings that seals the connection of windows and air outlets with the roof decking, and consists of a top flashing, a bottom flashing, side channels, and a connector. The top flashing, the bottom flashing and the side channels are preferably standard elements used in typical sets of roof windows. The connector, sealing connection of the system window with the air outlet, is an additional element of the flashing set within the framework of the proposed system. Depending of the configurations described above, according to the first case or the second case, the connector constitutes an intermediary element between the top flashing, being the flashing of the air outlet in these cases, and the side channels, or between the bottom flashing, being the flashing of the system window, and the side channels.

**[0020]** In order to maintain leaktightness at connections of the flashing set elements, the connector has channel profiles on both edges, for lap joining with the side channels and, depending on its location, with the top flashing or the bottom flashing. The channel profiles in the connector have preferably a shape of a channel profile, allowing tight lap joining of one element with the other.

**[0021]** For sealing of the connection of system windows having side air outlets with the roof decking, the required flashing set is individually adjusted depending on chosen configuration of system windows having side air outlets.

**[0022]** A base window according to the proposed embodiment, with main dimensions marked, is shown in Fig. 1.

**[0023]** A system window set with an air outlet mounted beside the frame top member, with main dimensions marked, is shown in Fig. 2.

**[0024]** A system window set with an air outlet mounted beside the frame bottom member, with main dimensions marked, is shown in Fig. 3.

**[0025]** A system window set with an air outlet mounted beside one of the frame side members, with main dimen-

sions marked, is shown in Fig. 4.

**[0026]** A system window set with two air outlets mounted beside the frame top member, with main dimensions marked, is shown in Fig. 5.

**[0027]** A system window set with two air outlets mounted beside one of the frame side members, with main dimensions marked, is shown in Fig. 6.

**[0028]** A full flashing set for the window system according to the invention is shown as an exploded isometric drawing Fig. 7; Fig. 8. shows a complete window with one air outlet, installed beside the frame top member of the window frame and the sheet metal flashing.

**[0029]** The basic element of the system is constituted by a base window 1 shown in Fig. 1 with main dimensions marked, i.e. width  $S_b$ , height  $W_b$  and thickness  $G$ . These dimensions are a reference for other dimensions of the system. System windows and air outlets are complementary elements of the system. Depending on the installation place of the air outlet, basically three cases may be distinguished.

**[0030]** In the first case, shown in Fig. 2, the base window 1 is replaced by a system window 2 and the top air outlet 3. The top air outlet 3 is mounted beside the frame top member 21 of the system window 2. The total length  $L_n$  of the top air outlet 3 is equal to the width  $S_s$  of the system window 2 and, according to the proposed window system, equal to the width  $S_b$  of the base window 1, shown in Fig. 1. Depths  $G$  of the top air outlet 3 and the system window 2 are preferably equal to the depth  $G$  of the base window 1. Height  $W_n$  of the top air outlet 3 is an element of the proposed window system and this dimension is a difference between the height  $W_b$  of the base window 1 and the height  $W_s$  of the system window 2. While assembled, the system window 2 and the top air outlet 3 preferably have the size of the base window 1. Because of allowable working tolerances, a slight difference in sizes may occur, however it should remain in the limits of 5% of the individual dimensions, not more than several millimetres.

**[0031]** The multi-element flashing set 4 shown in Fig. 7 and Fig. 8, being a complementary elements of the window system, sealing connection of the windows and the air outlets with the roof decking, consists of a top flashing 41, a bottom flashing 42, side channels 43 and a connector 44. The connector 44 is intended for sealing the connection of the system window 2 with the air outlet 3. Installation of elements of the flashing set 4 is realised in the sequence proper for the lap joint: the bottom flashing 42, the side channels 43, the connector 44 and the surmounting top flashing 41. In order to maintain leak-tightness at connections of the flashing set 4 elements, the connector 44 has channel profiles 441 on both edges, for tight lap joining with the side channels 43 and, depending on its location, with the top flashing 41 or the bottom flashing 42.

**[0032]** The flashing set 4 is used also for sealing the connection of the base window 1 with the roof decking. The connector 44 is an unnecessary element in this con-

figuration. The side channels 43 joins as laps with the top flashing 41 and the bottom flashing 42, having the length sufficient to replace the channel profiles 441 belonging to the connector 44.

**[0033]** In the second case, shown in Fig. 3, the bottom air outlet 5 is mounted beside the frame bottom member 23 of the system window 2. The total length  $L_n$  of the bottom air outlet 5 is equal to the width  $S_s$  of the system window 2 and to the width  $S_b$  of the base window 1, shown in Fig. 1. The depths  $G$  of the bottom air outlet 5 and the system window 2 are preferably equal to the depth  $G$  of the base window 1. Height  $W_n$  of the bottom air outlet 5 is an element of the proposed window system and this dimension is a difference between the height  $W_b$  of the base window 1 and the height  $W_s$  of the system window 2. While assembled, the system window 2 and the top air outlet 3 preferably have the size of the base window 1. Other conditions are the same as those of the first case described above.

**[0034]** The flashing set 4 shown in detail in the description of the first case may also be used in the second case, however the installation sequence of its individual elements requires swapping. Installation of elements of the flashing set 4 is realised in the sequence proper for the lap joint: the bottom flashing 42, the connector 44, the side channels 43 and the surmounting top flashing 41.

**[0035]** In the third case, shown in Fig. 4, the side air outlet 6 is mounted beside the frame side member 22. Its total length  $L_n$  is preferably equal to the height  $W_b$  of the base window 1 shown in Fig. 1. Height  $W_s$  of the system window 2 is preferably equal to the height  $W_b$  of the base window 1. Depths  $G$  of the side air outlet 6 and the system window 2 are preferably equal to the depth  $G$  of the base window 1. Height  $W_n$  of the side air outlet 6 is an element of the proposed window system and this dimension is preferably a difference between the width  $S_b$  of the base window 1 and the width  $S_s$  of the system window 2.

**[0036]** Within the framework of the proposed window system, installation of a higher number of air outlets in one window opening is also possible. They are a modification of one of the three cases presented above.

**[0037]** For example, one of possible combinations, being a modification of the first case according to the invention, is shown in Fig. 5. It comprises a system window 2', with height  $W_s$ , next lower one in the series of standard sizes in relation to the system window 2, and two top air outlets 3 mounted, one after the other, beside the frame top member 21'. Such a set meets the requirements of a window set according to the invention, meaning that the total height  $W_s$  of the system window and the heights  $W_n$  of two top air outlets 3 while assembled correspond basically to the height  $W_b$  of the base window.

**[0038]** A similar arrangement, shown in Fig. 6, may be assembled in the case of mounting of two side air outlets 6 beside one of the frame side members 22" of the system window 2". Assembly of the system window 2", with width  $S_s$  as next lower one in the series of standard sizes

in relation to the system window 2 and two side air outlets 6 with the height  $W_n$ , yields the total width  $S_b$  of the base window 1.

### Claims

1. A window system, composed of modules in the form of windows, particularly of roof windows, with various sizes forming a size series, and of the air outlets mounted beside the window on the external surface of the window frame which is basically perpendicular to the surface of the window glazing, the window being composed of, among others, a window frame comprising a frame top member, a frame bottom member and frame side members connecting them, **characterised in that** it comprises at least one base window (1) with a predefined size, as well as at least one system window (2) and at least one air outlet mounted beside the system window (2), with total size while assembled basically corresponding to the size of the base window (1).
2. A window system according to claim 1, **characterised in that** it has a top air outlet (3), a bottom air outlet (5) and a side air outlet (6).
3. A window system according to claim 2, **characterised in that** the top air outlet (3) is mounted beside the frame top member (21) of the system window (2).
4. A window system according to claim 1, **characterised in that** the bottom air outlet (5) is mounted beside the frame bottom member (23) of the system window (2).
5. A window system according to claim 3 or 4, **characterised in that** the total height dimension  $W_s$  of the system window (2) and the height  $W_n$  of the top air outlet (3) or the bottom air outlet (5), while assembled, basically corresponds to the height  $W_b$  of the base window (1).
6. A window system according to claim 3 or 4, **characterised in that** the length  $L_n$  of the top air outlet (3) or the bottom air outlet (5) and the width  $S_s$  of the system window (2) are basically equal to the width  $S_b$  of the base window (1).
7. A window system according to claim 2, **characterised in that** the side air outlet (6) is mounted beside the frame side member (22) of the system window (2).
8. A window system according to claim 7, **characterised in that** total width dimension  $S_s$  of the system window (2) and the height  $W_n$  of the side air outlet (6), while assembled, basically corresponds to the width  $S_b$  of the base window (1).
9. A window system according to claim 7, **characterised in that** the length  $L_n$  of the side air outlet (6) and the height  $W_s$  of the system window (2) are basically equal to the height  $W_b$  of the base window (1).
10. A window system according to claim 3 or 4, **characterised in that** it comprises a system window (2') and at least two air outlets, optionally top air outlets (3) or bottom air outlets (5), mounted beside the frame top member (21') or the frame bottom member (23'), with the outlets' total height, while assembled, basically corresponding to the height  $W_b$  of the base window (1).
11. A window system according to claim 7, **characterised in that** it comprises a system window (2'') and at least two side air outlets (6) mounted beside the frame side members (21''), with total width consisting of the width  $S_s$  of the system window (1) and the height  $W_n$  of the side air outlets (6), while assembled, basically corresponding to the width  $S_b$  of the base window (1).
12. A window system according to claim 1 and any of the claims 5, 6, 8, 9, 10, and 11, **characterised in that** the size difference between the base window (1) and the system window (2), (2') or (2'') with at least one air outlet is preferably equal to zero, and not larger than 5%.
13. A window system according to claim 3 or 4, **characterised in that** it has a multi-element flashing set (4), sealing connection of the window system elements with the roof decking, the flashing set being composed of a top flashing (41), a bottom flashing (42), side channels (43) and a connector (44).
14. A window system according to claim 13, **characterised in that** the connector (44) is an element of the flashing set (4), sealing the connection of the system window (2) or (2') with the top air outlet (3) or the bottom air outlet (5), the connector being connected with the sheet metal flashing of the frame top member (21) or the frame bottom member (23) and with the sheet metal flashing of the top air outlet (3) or the bottom air outlet (5).
15. A window system according to claim 13, **characterised in that** the connector (44) is an element of the flashing set (4), connected by a lap joint with the side channels (34) and the top flashing (41) or the bottom flashing (42).

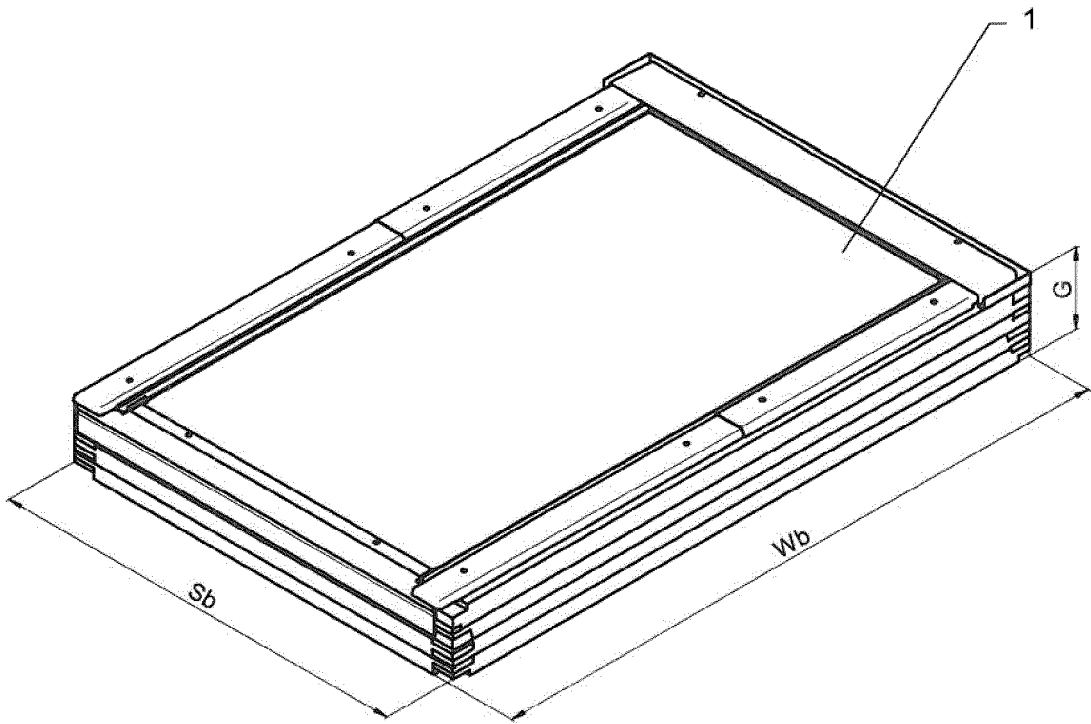

Fig. 1

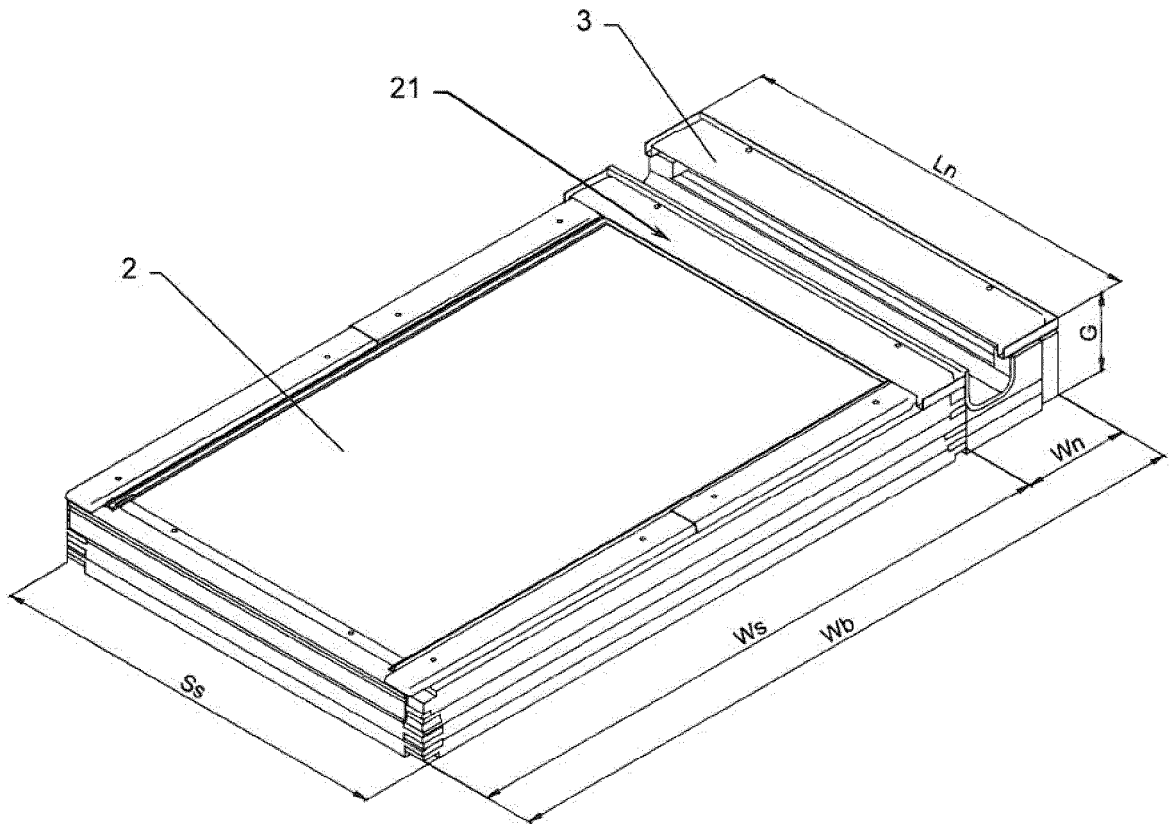

Fig. 2

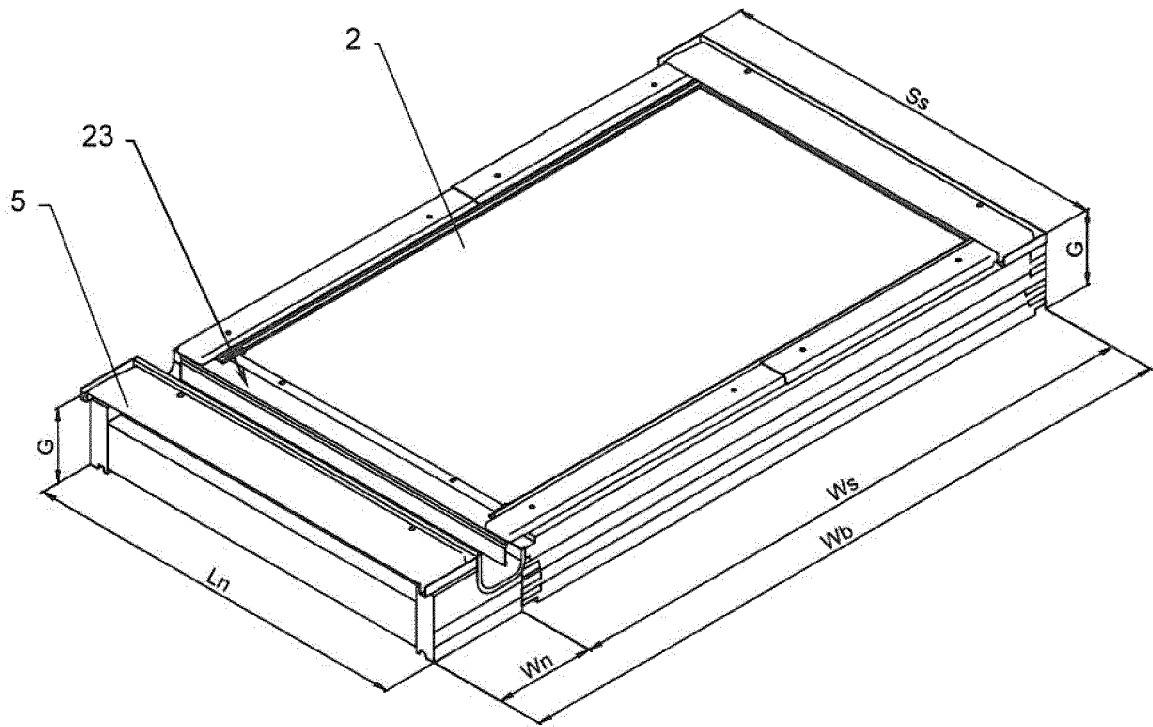

Fig. 3

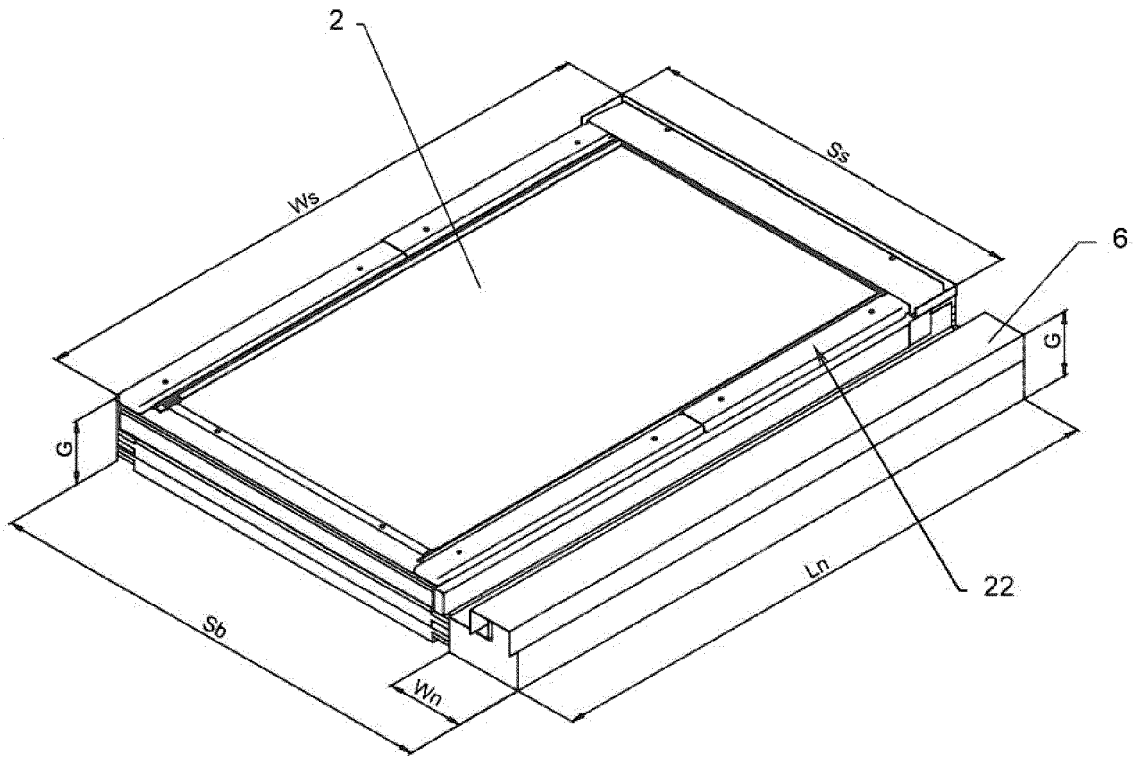

Fig. 4

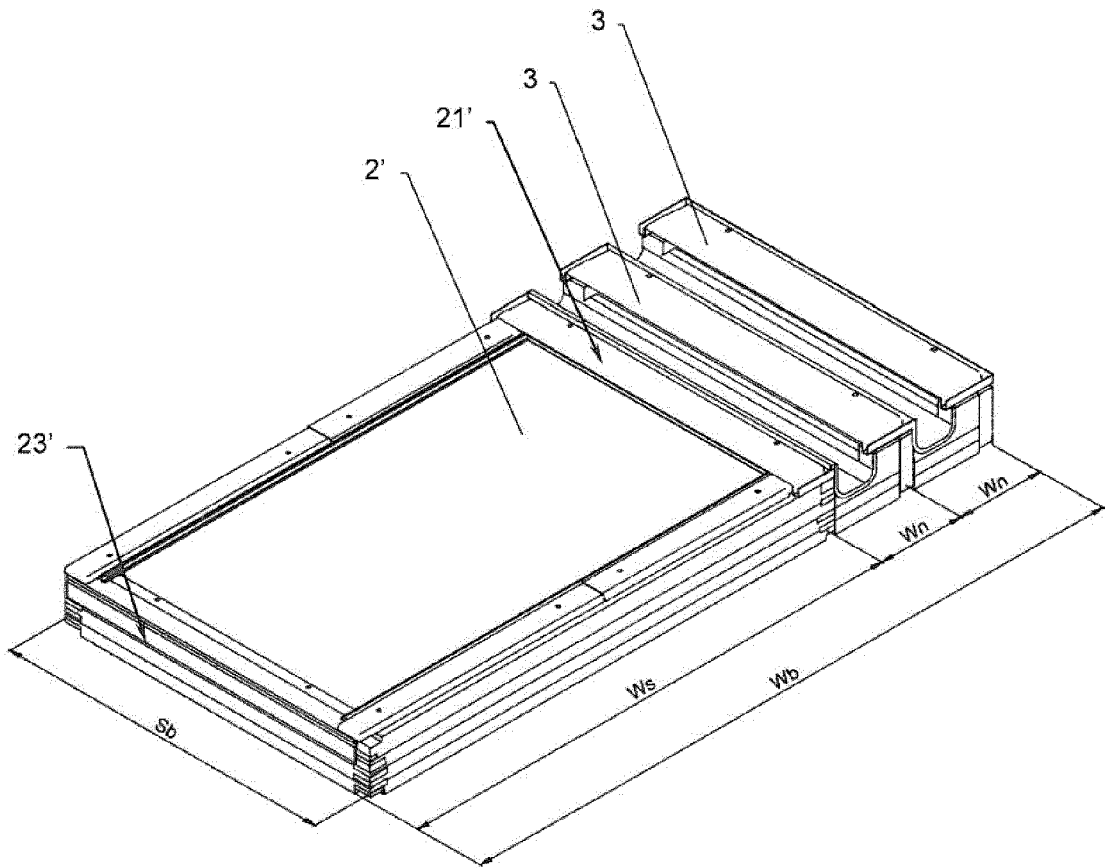

Fig. 5

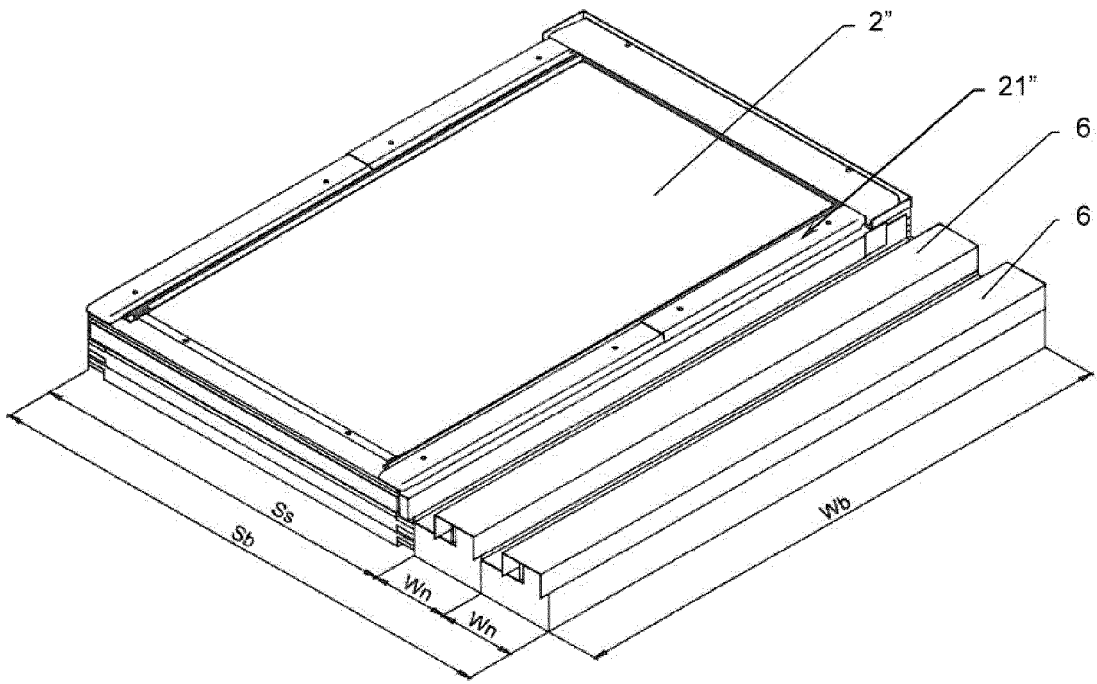

Fig. 6

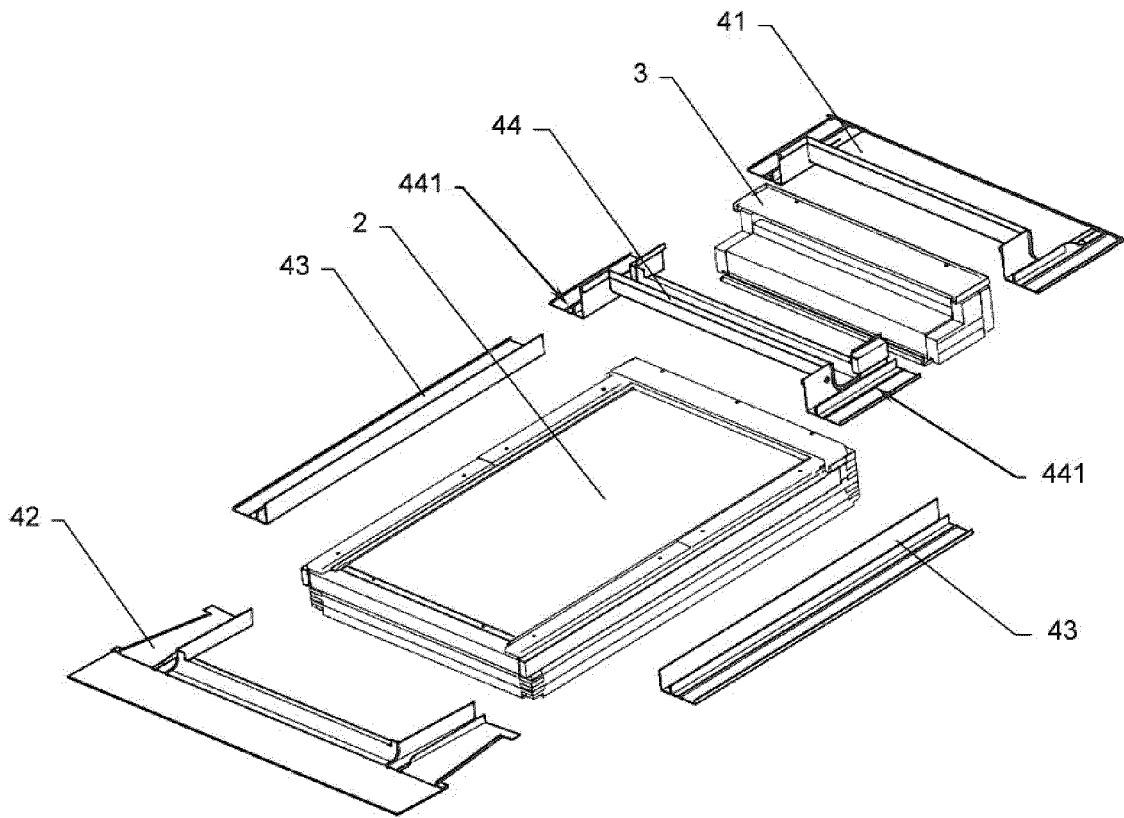

Fig. 7

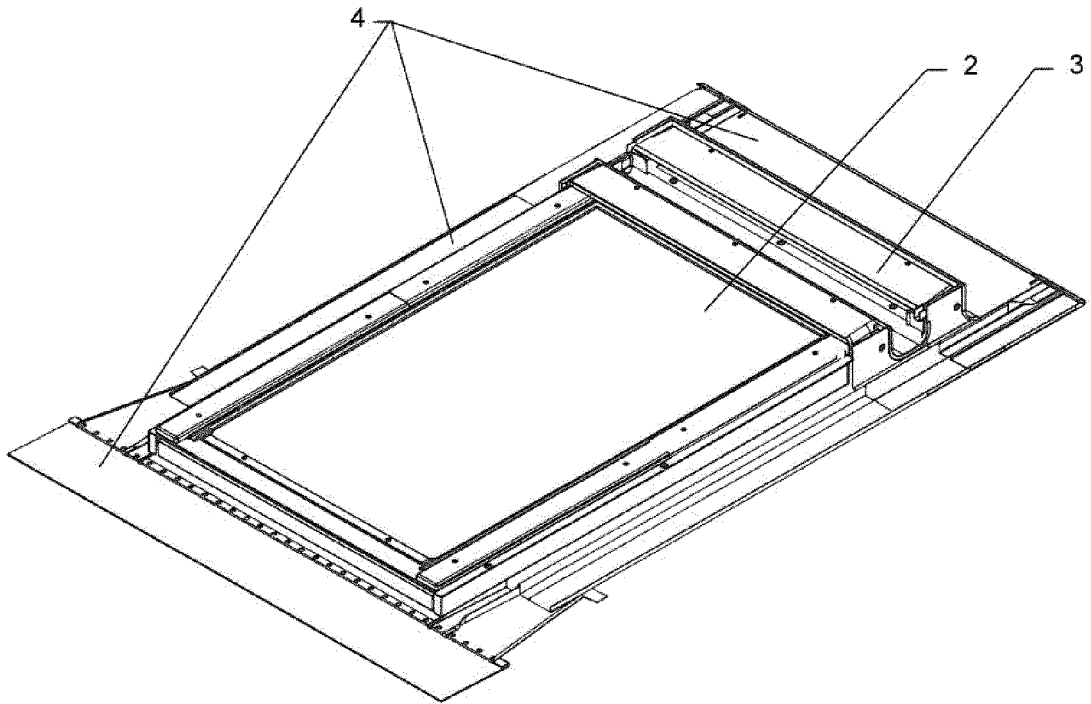

Fig. 8

**REFERENCES CITED IN THE DESCRIPTION**

*This list of references cited by the applicant is for the reader's convenience only. It does not form part of the European patent document. Even though great care has been taken in compiling the references, errors or omissions cannot be excluded and the EPO disclaims all liability in this regard.*

**Patent documents cited in the description**

- WO 2008133539 A2 [0003]
- WO 03001017 A1 [0004]
- WO 2005038165 A1 [0004]
- EP 1656484 B1 [0006]