

(No Model.)

2 Sheets—Sheet 1.

S. P. HEDGES.  
DREDGER.

No. 523,891.

Patented July 31, 1894.

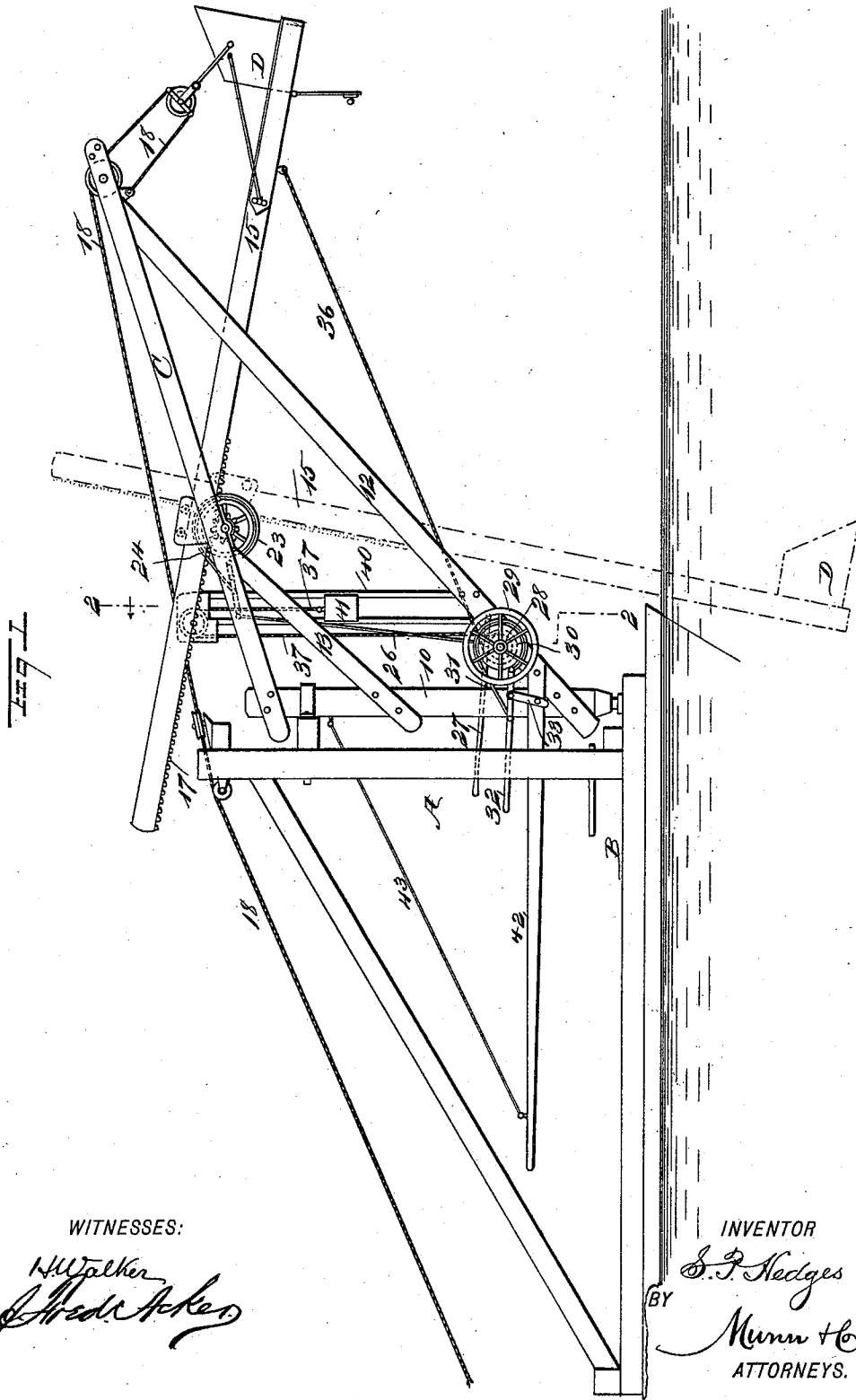

WITNESSES:

*H. Walker*  
*J. H. Hedges*

INVENTOR

*S. P. Hedges*

BY

*Munn & Co*  
ATTORNEYS.

(No Model.)

2 Sheets—Sheet 2.

S. P. HEDGES.  
DREDGER.

No. 523,891.

Patented July 31, 1894.

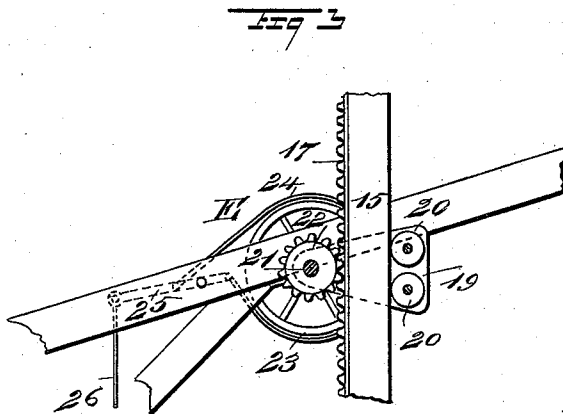
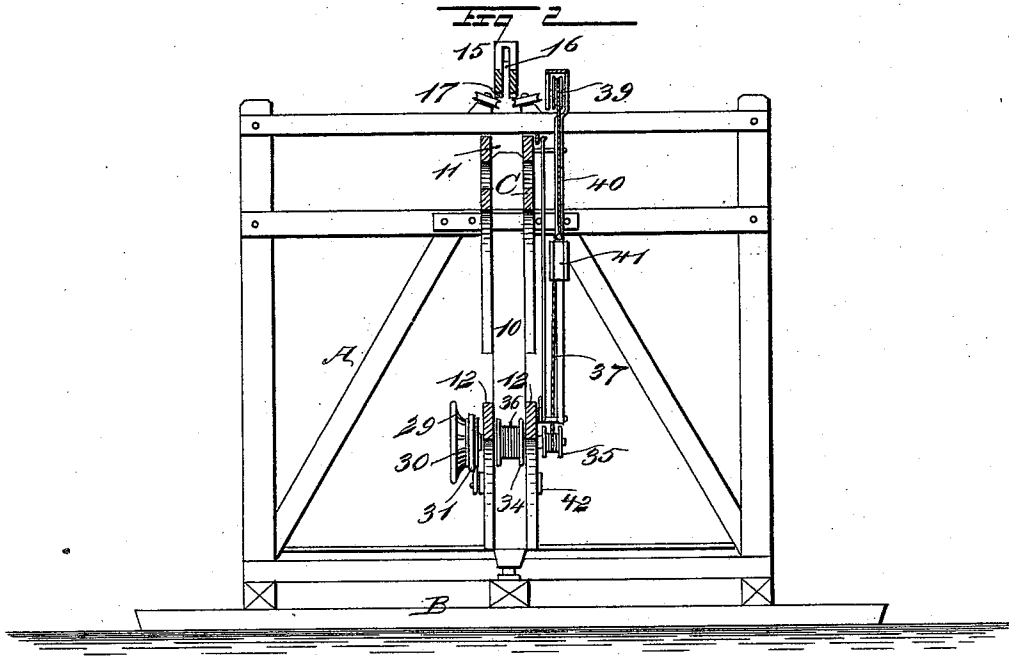

WITNESSES:

*H. Walker*  
*S. P. Hedges*

INVENTOR

*S. P. Hedges*  
BY *Munn & Co*

ATTORNEYS.

# UNITED STATES PATENT OFFICE.

SAMUEL P. HEDGES, OF GREENPORT, NEW YORK.

## DREDGER.

SPECIFICATION forming part of Letters Patent No. 523,891, dated July 31, 1894.

Application filed April 11, 1894. Serial No. 507,164. (No model.)

*To all whom it may concern:*

Be it known that I, SAMUEL P. HEDGES, of Greenport, in the county of Suffolk and State of New York, have invented a new and useful Improvement in Dredgers, of which the following is a full, clear, and exact description.

My invention relates to an improvement in dredgers, and especially to an improvement upon the dredger patented to myself February 13, 1894, No. 514,829, the object of the invention being to provide a simple device for holding back, lowering, and controlling the outward movement of the dipper handle.

The invention consists in the novel construction and combination of the several parts, as will be hereinafter fully set forth and pointed out in the claims.

Reference is to be had to the accompanying drawings, forming a part of this specification, in which similar figures and letters of reference indicate corresponding parts in all the views.

Figure 1 is a side elevation of the improved dredger, illustrating the dipper arm in elevated position in positive lines and in dredging position in dotted lines. Fig. 2 is a transverse vertical section taken practically on the line 2—2 of Fig. 1; and Fig. 3 is a detail view of the brake mechanism and guide for the dipper arm.

In carrying out the invention the frame A is designed to be portable, and to be removably placed upon a float B, the frame comprising a vertical and a horizontal section, the horizontal section being supported by the float. A vertical shaft 10, is journaled in suitable bearings at the central portion of the vertical section of the frame A, and this shaft 10, has attached to its upper end a crane C, which as shown in Fig. 2, is provided with a longitudinal slot or opening 11 extending substantially from its front to its rear end. The crane is supported in an elevated position by means of a brace 12, which preferably consists of two parallel bars or beams attached at their outer ends to the outer portion of the crane and secured at their lower ends to the shaft 10. The crane is further supported through the medium of a brace 13, attached to the shaft 10 and to the crane

proper preferably at the rear of its center, as shown in Fig. 1.

The dipper D may be of any suitable or approved construction, but is usually provided with a drop bottom, as shown in the drawings. The dipper is further provided with an attached arm 15, and the said arm extends rearward through the opening in the crane, being provided, especially at its rear, with a longitudinal slot or opening 16, as shown in Fig. 2; and the rear portion of the dipper arm upon its under face has secured to it a rack 17. A hoist rope 18, carried from the hoisting drum is made to pass over suitable pulleys located upon the vertical section of the frame A, through the slot in the dipper arm, over a friction pulley at the upper end of the crane, and over a second pulley attached to the bail of the dipper, the opposite end of the hoisting rope being attached in any suitable or approved manner to the crane, as illustrated in Fig. 1.

A casing 19, is pivoted in the slotted portion of the crane, preferably at a point rearward of its center, the outer end of the casing being provided with two friction rollers 20, as shown in Fig. 3, and the inner end of the casing is usually pivoted upon a shaft 21, extending transversely of the crane and located in suitable bearings, which shaft carries a pinion 22, located in the slotted portion of the crane and adapted to engage with the rack 17 of the dipper arm. At the outer end of the shaft 21 a brake wheel 23, is firmly secured, and this brake wheel is engaged by a strap brake 24, one end of the brake being attached to the outer end of a lever 25, fulcrumed upon the crane, the other end of the brake being secured to the said lever at the rear of its fulcrum; and the rear end of the lever 25, is connected by a link 26, with a hand lever 27, capable of being operated from the float. The above construction is shown and described in the patent upon which this application is an improvement.

The main feature of this invention consists in journaling upon the lower portion of the main crane brace 12 a shaft 28, which shaft at one outer end is preferably provided with a hand wheel 29, firmly secured thereto, and likewise a brake wheel 30, said brake wheel

being engaged by a strap brake 31, which is attached to the inner end of a hand lever 32, fulcrumed upon a convenient support, usually upon a bracket 33, secured to a shifting lever 42; and the opposite end of the brake strap 31 is secured to the hand lever 32 at the rear of its fulcrum, so that by depressing the lever 32 the brake will be applied to the wheel. The shaft 28, has likewise secured upon it in the space between the members of the brace 12 a drum 34, and at the opposite end of the shaft it is provided with a second and preferably smaller drum 35.

The hold-back rope or chain 36, is attached to the larger drum 34 and to the dipper arm at a point near its forward or outer end. A rope or chain 37 is likewise attached to and adapted to be wound upon the smaller drum 35, but in a reverse direction to the hold-back rope or chain 36. This rope or chain 37 is carried upward over a pulley 39, located at the top of a guide-way 40 vertically placed and secured to the crane and its brace 12, as shown in Figs. 1 and 2. The upper end of the rope 37 carried by the smaller drum 35 is attached to a weight 41, which has guided movement in the guide-ways 40.

In the operation of this dredger, after the dipper is loaded, the hoisting mechanism is set in operation and the dipper arm is elevated, and as the dipper arm is elevated the pull-back rope or chain 36 will be drawn from its drum 34, causing the shaft 28 to revolve, and likewise causing the rope or chain 37 connected with the weight 41 to be wound upon the drum 35, thus elevating the weight. The brake 27, attached to the brake mechanism of the crane arm, is then applied to prevent the dipper arm moving backward, and a lever 42, which is attached to the lower portion of the crane brace 12 on the lower portion of the shaft 10, may then be moved to one side, so as to carry the crane and dipper arm over the point where the load is to be dumped, the said shifting lever 42 being usually supported at its free end by a link 43; but the crane may be revolved by other means if desired. When the hoist rope is slackened the dipper arm will drop downward, slackening thereby the pull-back rope or chain 36, which will be wound upon the drum 34 by the action of the weight 41 descending; and the lower end of the dipper arm will then be drawn inward to a position which will enable the dipper to enter the ground beneath the float, as shown in dotted lines in Fig. 1. If however, the pull-back rope is not drawn in sufficiently to accomplish this result by the action of the weight 41, it may be wound further upon its drum by manipulating the hand wheel 29.

The dipper arm, when in vertical position, is released from the friction strap 24, and is suspended upon the auxiliary drum and lowered by releasing the auxiliary friction strap 31, allowing the dipper to enter the soil without a sudden jar or drop, the manipulation of the dipper being under the complete control of the operator through the medium of the auxiliary brake. By this means it will be observed that the position of the lower end of the dipper arm may be controlled, being made to fall either perpendicularly or with any desired inward inclination.

Having thus described my invention, I claim as new, and desire to secure by Letters Patent—

1. In a dredger, the combination, with a frame, a crane carried thereby, a dipper arm, and a mechanism substantially as described for raising and lowering said arm, of a controlling mechanism for the dipper arm, consisting of a shaft journaled in a support moving with the crane, drums secured upon said shaft, a pull-back rope or chain connected with the dipper arm and wound upon one of the drums, an actuating rope or chain connected with the other drum on the shaft and wound thereon in an opposite direction to the winding of the pull-back rope or chain upon its drum, the actuating rope or chain being connected with a weight capable of rising and falling, and a brake mechanism connected with the shaft carrying said drums, as and for the purpose specified.

2. In a dredger, the combination, with a frame, a crane carried thereby, a dipper arm, and a mechanism substantially as described, for raising and lowering said arm, of a controlling mechanism for the dipper arm, consisting of a shaft journaled in a support moving with the crane, drums secured upon said shaft, a pull-back rope or chain connected with the dipper arm and wound upon one of the drums, an actuating rope or chain connected with the other drum on the shaft and wound thereon in an opposite direction to the winding of the pull-back rope or chain upon its drum, the actuating rope or chain being connected with a weight capable of rising and falling, a brake wheel located on said shaft, a brake engaging with said wheel, and means, substantially as shown and described, for operating the brake, and a hand wheel attached to the shaft whereby it may be operated by hand, all combined for operation as and for the purpose set forth.

SAMUEL P. HEDGES.

Witnesses:

J. FRED ACKER,  
C. SEDGWICK.