

(19) **DANMARK**

(10) **DK/EP 3626675 T3**



Patent- og
Varemærkestyrelsen

(12) **Oversættelse af
europæisk patentskrift**

-
- (51) Int.Cl.: **B 66 F 9/075 (2006.01)**
- (45) Oversættelsen bekendtgjort den: **2022-03-14**
- (80) Dato for Den Europæiske Patentmyndigheds bekendtgørelse om meddelelse af patentet: **2022-01-19**
- (86) Europæisk ansøgning nr.: **19198147.1**
- (86) Europæisk indleveringsdag: **2019-09-18**
- (87) Den europæiske ansøgnings publiceringsdag: **2020-03-25**
- (30) Prioritet: **2018-09-18 NL 2021661**
- (84) Designerede stater: **AL AT BE BG CH CY CZ DE DK EE ES FI FR GB GR HR HU IE IS IT LI LT LU LV MC MK MT NL NO PL PT RO RS SE SI SK SM TR**
- (73) Patenthaver: **Terberg Kinglifter B.V., Baronieweg 23a, 3403 NL IJsselstein, Holland**
- (72) Opfinder: **DE RUITER, Martijn, p/a Baronieweg 23a, 3403 NL IJsselstein, Holland
van der Heide, Rolf, p/a Baronieweg 23a, 3403 NL IJSSELSTEIN, Holland**
- (74) Fuldmægtig i Danmark: **Novagraaf Brevets, Bâtiment O2, 2 rue Sarah Bernhardt CS90017, F-92665 Asnières-sur-Seine cedex, Frankrig**
- (54) Benævnelse: **LØFTETRUCK MED FORLÆNGEDE HJULARME OG FREMGANGSMÅDE TIL LASTNING OG/ELLER LOSNING I ET LASTRUM**
- (56) Fremdragne publikationer:
NL-C2- 1 001 917
US-A- 3 799 379
US-A- 4 571 139
US-A- 5 879 124

DESCRIPTION

[0001] The present invention relates to a truck-mounted forklift truck. Such a truck-mounted forklift is usually used in combination with a truck for thereby loading and/or unloading the cargo space of such a truck.

[0002] US 5 879 124 A relates to a vehicle with a retractable rear wheel assembly. US 5 879 124 A discloses a truck-mounted forklift truck according to the preamble of the independent claim 1.

[0003] Truck-mounted forklifts are known in practice which are brought along by a truck in order to enable independent loading and/or unloading. Such a truck-mounted forklift is usually provided here with mounting elements whereby the truck-mounted forklift can be mounted on the cargo space, particularly on a truck, and can be brought along by such a truck. The forks of the truck-mounted forklift serve to pick up and/or set down the cargo.

[0004] Such truck-mounted forklift trucks are provided with a number of wheels, at least some of which are usually mounted on extendable wheel arms. The minimum overhang length, i.e. the space necessary behind the truck for mounting of a truck-mounted forklift to be brought along, can hereby remain limited. A problem is here that the extending of the wheel arms for use reduces the robustness of the truck-mounted forklift due to for instance clearance occurring between the extendable parts of a wheel arm. This may result in undesirable situations with additional wear and possibly even unstable cargo on the lifting arms during use.

[0005] The present invention has for its object to provide a truck-mounted forklift truck whereby the above stated problems are obviated or at least reduced, such that the loading and/or unloading of a cargo space using a truck-mounted forklift can be performed more efficiently.

[0006] This object is achieved with a truck-mounted forklift truck for loading and/or unloading a cargo space according to claim 1.

[0007] The truck-mounted forklift truck can be connected to a truck with cargo space or loading space in simple manner by providing a frame with mounting elements. In this manner a truck-mounted forklift can be brought along during transport and is thereby immediately available for loading and/or unloading using the forks of the truck-mounted forklift. Use need therefore not be made of a forklift truck at the location in question. The truck-mounted forklift is preferably provided here with a mast and associated drive in order to thereby further increase the utility of the truck-mounted forklift. Using the wheels and associated drive the truck-mounted forklift can be displaced over a ground surface, particularly during loading and/or unloading of a truck.

[0008] The truck-mounted forklift is preferably provided with a steering mechanism with which

at least some of the wheels are steerable. It is hereby possible to manoeuvre the truck-mounted forklift in effective manner when displacing cargo. Such a steering mechanism can take diverse forms, for instance with a gear rack construction or with a steering/turning cylinder. By providing extendable arms the truck-mounted forklift can take a compact form relative to the overhang length. This has the advantage that the space necessary on the rear side of the truck during transport can remain limited. This prevents loading space being lost due to the use of a truck-mounted forklift.

[0009] By providing a shaped guide the extending and preferably also retracting of the wheel arms can be performed in controlled manner. The shaped guide according to the invention is configured to align wheel arms in lateral direction for the purpose of extending and preferably retracting thereof. By guiding the relative movement of the (sub-)parts of the wheel arms undesired clearance in lateral direction is prevented or at least reduced. This increases the robustness of the truck-mounted forklift as a whole. The undesired movement of the cargo as a result of clearance in the wheel arms or sub-parts thereof is hereby additionally prevented. This increases the stability of the cargo during displacement with the truck-mounted forklift. This reduces the risk of accidents.

[0010] In addition, wear is reduced and preferably concentrated on the wheel arm guide by the aligned extending and preferably retracting of the wheel arms and wheel arm parts using the shaped guide. The lifespan of the wheel arm and thereby the truck-mounted forklift is hereby increased. The maintenance costs are also reduced. A further particular additional advantage is that inspection of possibly occurring wear is possible in simpler manner owing to the concentration thereof, preferably on the shaped guide.

[0011] In a currently preferred embodiment the alignment in a vertical direction during use is ensured by the own weight of the truck-mounted forklift. This provides for alignment of the (sub-)parts of the wheel arm from the underside.

[0012] The lateral alignment is therefore brought about by the shaped guide. This has the further advantage that relative tolerances for wheel arm parts need not be as precise. This simplifies production and mounting. This is particularly advantageous if wheel arms and wheel arm parts are manufactured from tubular profiles or bent plates. Such production can take place in simpler manner, whereby the cost price of the wheel arms in particular, and the truck-mounted forklift as a whole, can be limited.

[0013] The shaped guide is provided with a guide groove. This guide groove can be arranged in the outer wheel arm part or the inner wheel arm part. In a currently preferred embodiment an inner tubular part is provided extendably on an outer tubular profile. These two wheel arm parts are thereby provided extendably and retractably relative to each other. The guide groove is provided on at least one of these two parts. In a currently preferred embodiment the guide groove is provided on the inner part and a correspondingly shaped part (of the shaped guide) is arranged on the internal surface of the outer part. If desired, this can be attached as a separate part, of another material if desired.

[0014] In a currently preferred embodiment the shaped guide is provided on the upper side of the wheel arm, particularly on and/or between the sub-parts of the extendable wheel arm. A further shaped guide is still more preferably provided on the underside of the wheel arm. It is otherwise likewise possible to provide the shaped guide only on the underside. Providing two separate shaped guides, respectively on the underside and the upper side of the wheel arm, improves the guiding still further and intensifies the above stated effects further.

[0015] A further advantage of providing a shaped guide as separate component, or at least a part of a shaped guide as separate component, is that the shaped guide thereby preferably also functions to concentrate wear and that mounting and removal of the shaped guide is in addition made relatively simple. This makes maintenance and repairs considerably simpler because it is for instance possible to remove and replace this component of the wheel arm in simple manner. The guide is here for instance screwed fixedly to the tubular profile.

[0016] A further advantage is that by using the guides no additional filling is required on the sides between the separate sub-parts of the wheel arm. This simplifies production and mounting and additionally reduces the resistance during extending or retracting of the wheel arms.

[0017] In an advantageous embodiment according to the invention the wheel arm is formed wholly or partially from two sub-parts which are mutually connected with at least one lateral weld.

[0018] Providing at least one of the parts of the wheel arm from separate parts simplifies production of the wheel arm.

[0019] Providing separate parts for a sub-part of the wheel arm achieves that, instead of a tubular profile as starting material, it is possible to use sheet material as starting material. This sheet material can be bent in relatively simple manner with for instance an angle bending machine, after which separate parts are then mutually connected, preferably with a longitudinal weld on the side of the wheel arm for thereby providing said lateral weld. In a currently preferred embodiment such a weld is arranged on the side of the inner sub-part of the wheel arm, since alignment is in a currently preferred embodiment realized by providing the guides on the upper side and/or underside of the wheel arm. Hereby, there is sufficient space for the weld on the side. This even has the additional advantage that the weld can be completely welded through, whereby the connection between the separate parts of the inner sub-part of the extendable wheel arm in particular can be made extremely strong and robust.

[0020] According to the invention the guide groove is provided with a V-shaped groove.

[0021] Providing a V-shaped groove results in a self-centering, i.e. self-aligning, effect in that during the relative movement the separate sub-parts of the wheel arm are themselves urged into the correct position, and are held therein, by the shape. This results in an effectively

guiding element.

[0022] The V-shaped groove is provided here with two legs which are arranged at an angle in a range of 2-25°, preferably in the range of 5-20°. An effective guide groove, which can be realized in simple manner, can hereby be provided. In a currently preferred embodiment it is thus for instance possible to mutually connect two separate parts of an (inner) sub-part of the wheel arm via two lateral welds and to provide them with a shaped guide on the upper side and underside. The V-shaped groove can hereby be bent in effective manner in an angle bending machine, which groove can thereby also be realized sufficiently accurately.

[0023] In a currently preferred embodiment a V-shaped groove is provided both on the upper side and the underside of the wheel arm. In such an embodiment the angle on the upper side is for instance about 20°, and on the underside about 10°. It has been found that a good stability for the wheel arm is obtained hereby. It will be apparent that other angles are also possible according to the invention.

[0024] The shaped guide preferably comprises a separate guide plate which can be mounted separately on for instance the inner side of the outer tube of the wheel arm. This guide plate is preferably provided from a plastic material, such that the plastic wear part is realized. As already stated above, this enables an effective use including maintenance and repairs.

[0025] In a further advantageous embodiment the truck-mounted forklift truck further comprises one or more load carriers configured to carry cargo during displacement of the truck-mounted forklift in a lateral direction, and provided with a tilting mechanism for moving the load carrier downward and an unfolding mechanism for simultaneously unfolding a support.

[0026] Providing a tilting mechanism and an unfolding mechanism also enables a support to be unfolded during lowering of the load carrier from a folded-up position. This has the advantage that the overhang length remains limited. This makes transport with the truck-mounted forklift according to the invention more effective.

[0027] The invention also relates to a truck comprising a cargo space and a truck-mounted forklift truck as described above, wherein the truck is provided with coupling elements configured to be able to couple the truck-mounted forklift to the truck in co-action with the mounting elements of the truck-mounted forklift.

[0028] Such a truck provides the same effects and advantages as stated for the truck-mounted forklift.

[0029] The invention further also relates to a method for loading and/or unloading a cargo space of a truck, comprising the steps of:

- uncoupling the truck-mounted forklift truck from the truck;
- extending the wheel arms;

- loading and/or unloading the truck with the truck-mounted forklift truck; and
- retracting the wheel arms and coupling the truck-mounted forklift truck to the truck.

[0030] Such a method provides the same effects and advantages as stated for the truck-mounted forklift truck and/or the truck.

[0031] By making use of the invention cargo can be transported in effective manner with the truck-mounted forklift truck as described above. This is because the robustness and stability are increased, such that dangerous situations are also avoided.

[0032] Further features, advantages and details of the invention are described on the basis of preferred embodiments thereof, wherein reference is made to the accompanying drawings, in which:

- figure 1 shows a view of a truck-mounted forklift truck in an embodiment according to the invention;
- figures 2 and 3 show views of a wheel arm from the truck-mounted forklift according to figure 1; and
- figures 4 and 5 show views of a load carrier in an embodiment of the truck-mounted forklift according to the invention.

[0033] Truck-mounted forklift truck 2 (figure 1) is provided with frame 4, wherein front wheel 6 and second front wheel 8 are arranged on the front side. Steered wheel 10 is provided on the rear side. In a first embodiment front wheels 6, 8 are provided fixedly and in a second embodiment also provided steerably.

[0034] In the shown embodiment truck-mounted forklift truck 2 is provided with mast construction 12 with forks 14 for picking up and setting down cargo. In the shown embodiment truck-mounted forklift 2 is further provided with cab 14 with seat 16 and steering system 18.

[0035] In the shown embodiment (figure 1) wheels 6, 8 are provided on the front side of truck-mounted forklift 2, arranged on wheels arms 20. Two load carriers 22 are further arranged in the shown embodiments.

[0036] In the shown embodiment wheel arm 20 is provided with a first sub-part 24 and second sub-part 26 (figures 2, 3). In the shown embodiment the first sub-part 24 is embodied as an outer tubular profile which is mounted fixedly on frame 4 of truck-mounted forklift 2.

[0037] In the shown embodiment (figures 2, 3) inner sub-part 26 is embodied as a tubular profile which is slidable in first sub-part 24. In the shown embodiment wheel guide 28 is formed by the V-shaped groove 30, arranged in inner, i.e. in use front, sub-part 26 in longitudinal

direction thereof, and guide 32 which is secured to fixed sub-part 24 of wheel arm 20. In the shown embodiment guide 32 is arranged on the upper side of wheel arm 20, between sub-parts 24, 26. In the shown embodiment a second wheel guide 34 with an inverse V-shaped groove 36 and second guide 38 is also provided on the underside of wheel arm 20. Also provided is drive 40 which makes it possible to extend or retract sub-parts 24, 26 relative to each other.

[0038] In the shown embodiment front sub-part 26 is provided from separate parts, particularly upper part 42 and lower part 44 (figure 3). In this embodiment both parts are manufactured using an angle bending machine and then mutually connected using weld 46. Weld 46 extends in the longitudinal direction on side 48 of wheel arm 20. In this shown embodiment upper shaped guide 28 is therefore arranged on upper side 50 of wheel arm 20 and second guide 32 on underside 52 of wheel arm 20. On sides 48 space 54 is available between sub-parts 24, 26. This enables and/or simplifies production tolerances and welds 46. In the shown embodiment guide 32, 38 is provided with a plastic material. If desired, a wear indicator can be provided here which indicates whether guide 32, 38 has to be replaced.

[0039] In the shown embodiment wheel guides 32, 38 are provided with two legs 56, 58 (figure 3). Legs 58 are provided at angle α to the horizontal. In the shown embodiment angle α lies in the range of 2-25°. It will be apparent that other angles and shapes are likewise possible according to the invention. In the shown embodiment legs 56, 58 are provided to fit substantially against respectively the upper side and underside of sub-part 26. Wheel guides 32, 38 are as it were provided truncated by the truncation at the position where legs 56, 58 converge in order to reduce friction, among other things.

[0040] Load carriers 22 (figure 4, 5) carry the cargo particularly during the lateral displacement of goods. During such a lateral displacement wheels 6, 8, 10 of truck-mounted forklift 2 are in the shown embodiment placed completely laterally, whereby the truck-mounted forklift is displaceable in lateral direction B instead of in forward direction A. This is applied particularly in the case of elongate goods. In such a case load carriers 22 then contribute to a greater stability in that, in the case of two load carriers 22, they are arranged at a greater mutual distance than forks 14 of truck-mounted forklift 2. In the shown embodiment a load carrier 22 is secured to frame 4 of truck-mounted forklift 2 using support 60. Support 60 is thereby mounted fixedly on truck-mounted forklift 2. Carrier part 62 is rotatable around shaft 64. Using connecting rod 66 as unfolding mechanism, support 68 is folded down automatically when load carrier 22 is moved downward around rotation shaft 64 in rotation direction C. In the shown embodiment support 68 is provided with foot 70. By making use of the tilting and unfolding mechanism, wherein support 68 rotates around shaft 72, the necessary space for load carriers 22 in a folded-up state is limited. There is hereby no unnecessary adverse effect on the overhang length.

[0041] In the shown embodiment control of load carriers 22 takes place using cylinder 74. Automatic folding down and folding up of load carriers 22 is hereby simplified for a user. If desired, it is possible to perform such a movement manually.

[0042] During transport truck-mounted forklift 2 is usually connected to the rear side of a truck and/or mounted on or onto the loading floor thereof in a manner known in practice. This is usually possible without loss of cargo space or loading space of the relevant truck or trailer. The forks of mast construction 12 are herein for instance inserted into box beams of trucks. Optionally, support is found here on an additional frame and/or truck-mounted forklift 2 is fastened to the truck using chains.

[0043] When the desired location is reached, truck-mounted forklift 2 is uncoupled from the truck in known manner and then used to load and/or unload goods from the cargo space of the truck. During use a user steers truck-mounted forklift truck 2.

[0044] During use the wheel arms are extended and placed in a position of use. Inner (front) sub-part 26 of wheel arm 20 here performs a translating movement relative to the outer sub-part 24 of wheel arm 20. The shaped guide guides the front sub-part during the extending movement. When the wheel arm is retracted, a reverse movement is performed. If desired, it is possible not to extend wheel arm 20, or not to extend it wholly, during use. This has the advantage that it is possible to get close to cargo.

[0045] It will be apparent that different embodiments of truck-mounted forklift 2 are possible. As stated, it is for instance possible to provide a plurality of steerable wheels 10, for instance also on the front side, in combination with shown wheels 6, 8. All wheels are hereby preferably steerable. In such an embodiment front wheel 8 (figure 1) is for instance turned using a cylinder or, alternatively, with a separate turning cylinder 30. Wheel 6, 8 is here operatively connected to a frame part which is rotatable round a substantially vertical axis, or a rotation axis having at least a relatively large vertical component. This also applies to front wheel 6.

[0046] It is further possible to provide mast construction 12 in other embodiments, for instance with a so-called scissor mast.

[0047] The present invention is by no means limited to the above described preferred embodiments thereof. The rights sought are defined by the following claims, within the scope of which many modifications can be envisaged. It is thus for instance possible to manufacture parts of truck-mounted forklift 2 from plastic and/or metal. It is also possible to give truck-mounted forklift 2 a different lifting capacity, depending on the intended application.

REFERENCES CITED IN THE DESCRIPTION

Cited references

This list of references cited by the applicant is for the reader's convenience only. It does not

form part of the European patent document. Even though great care has been taken in compiling the references, errors or omissions cannot be excluded and the EPO disclaims all liability in this regard.

Patent documents cited in the description

- US5879124A [0002] [0002]

Patentkrav

1. Lastbilsmonteret gaffeltruck (2) til lastning og/eller losning i et lastrum, hvor den lastbilsmonterede gaffeltruck omfatter:
 - 5 – en ramme (4), der er forsynet med monteringslementer, der er konfigureret til montering af den lastbilsmonterede gaffeltruck (2) på en lastbil, der rummer lastrummet;
 - et sæt gafler (14) til opsamling og/eller nedsætning af en last under lastningen og/eller losningen;
 - 10 – én eller flere hjularme (20), der er arrangeret på rammen (4) og forsynet med et hjul (6, 8, 10), hvor hjularmene (20) kan forlænges, hvor hjularmen (20) er forsynet med en formet føring (28), der er konfigureret til at justere hjularmen (20) i lateral retning til justeret udføring og indtrækning af hjularmen (20), hvor den formede føring (28) er forsynet med en føringsrille,
 - 15 **kendetegnet ved, at føringsrillen er forsynet med en V-formet rille (30).**
2. Lastbilsmonteret gaffeltruck (2) ifølge krav 1, hvor den formede føring (28) er tilvejebragt på den øverste side (50) af hjularmen (20).
- 20 3. Lastbilsmonteret gaffeltruck (2) ifølge krav 1 eller 2, hvor den formede føring (28) er tilvejebragt på undersiden (52) af hjularmen (20).
4. Lastbilsmonteret gaffeltruck (2) ifølge ethvert af de foregående krav, hvor hjularmen (20) er dannet fra mindst to underdele (24, 26), der er indbyrdes forbundet med mindst én lateral svejsning (46).
- 25 5. Lastbilsmonteret gaffeltruck (2) ifølge ethvert af de foregående krav, hvor den V-formede rille (30) er forsynet med ben (56, 58) i en vinkel i området fra 2-25°, fortrinsvis i området fra 5-20°.
- 30 6. Lastbilsmonteret gaffeltruck (2) ifølge ethvert af de foregående krav, hvor den formede føring (28) desuden omfatter en føringsplade.

7. Lastbilsmonteret gaffeltruck (2) ifølge krav 6, hvor føringspladen omfatter en sliddel af plastik.
- 5 8. Lastbilsmonteret gaffeltruck (2) ifølge ethvert af de foregående krav, som desuden omfatter én eller flere ladningsbærere (22), der er konfigureret til at bære last under flytning af den lastbilsmonterede gaffeltruck (2) i en lateral retning, og forsynet med en vippemekanisme til at bevæge ladningsbæreren nedad og en udfoldningsmekanisme til samtidig udfoldning af en støtte (68).
- 10 9. Lastbil, der omfatter et lastrum og en lastbilsmonteret gaffeltruck (2) ifølge ethvert af de foregående krav, og som desuden er forsynet med koblingselementer, der er konfigureret til at koble den lastbilsmonterede gaffeltruck til lastbilen gennem fælles handling med monteringselementerne på den lastbilsmonterede gaffeltruck.
- 15 10. Fremgangsmåde til lastning og/eller losning af et lastrum i en lastbil, som omfatter trinnene:
- tilvejebringelse af en lastbil og en lastbilsmonteret gaffeltruck (2) ifølge ethvert af de foregående krav;
 - 20 – frakobling af den lastbilsmonterede gaffeltruck (2) fra lastbilen;
 - udstrækning af hjularmene (20);
 - lastning og/eller losning af lastbilen med den lastbilsmonterede gaffeltruck (2); og
 - 25 – indtrækning af hjularmene (20) og kobling af den lastbilsmonterede gaffeltruck (2) med lastbilen.

DRAWINGS

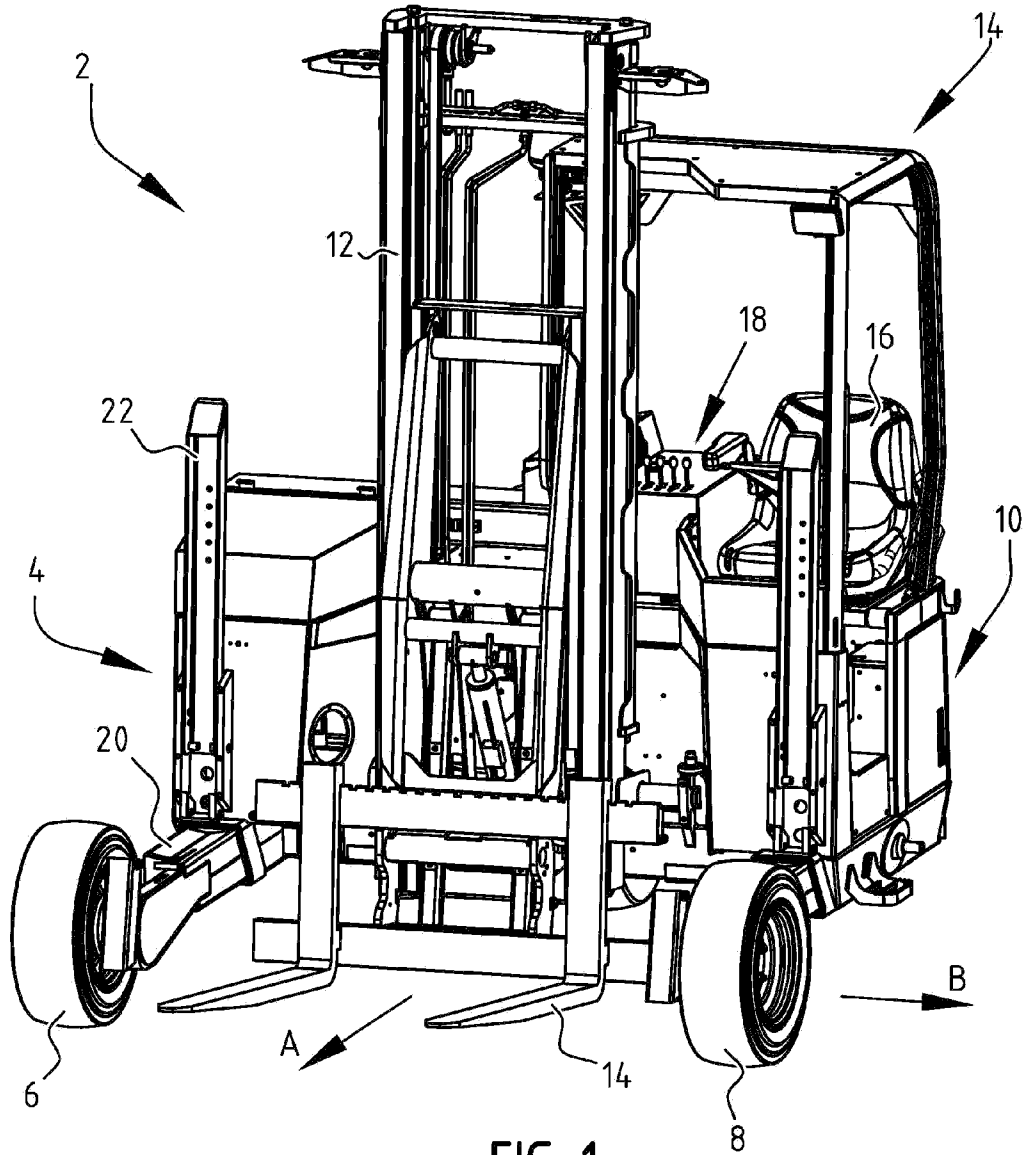
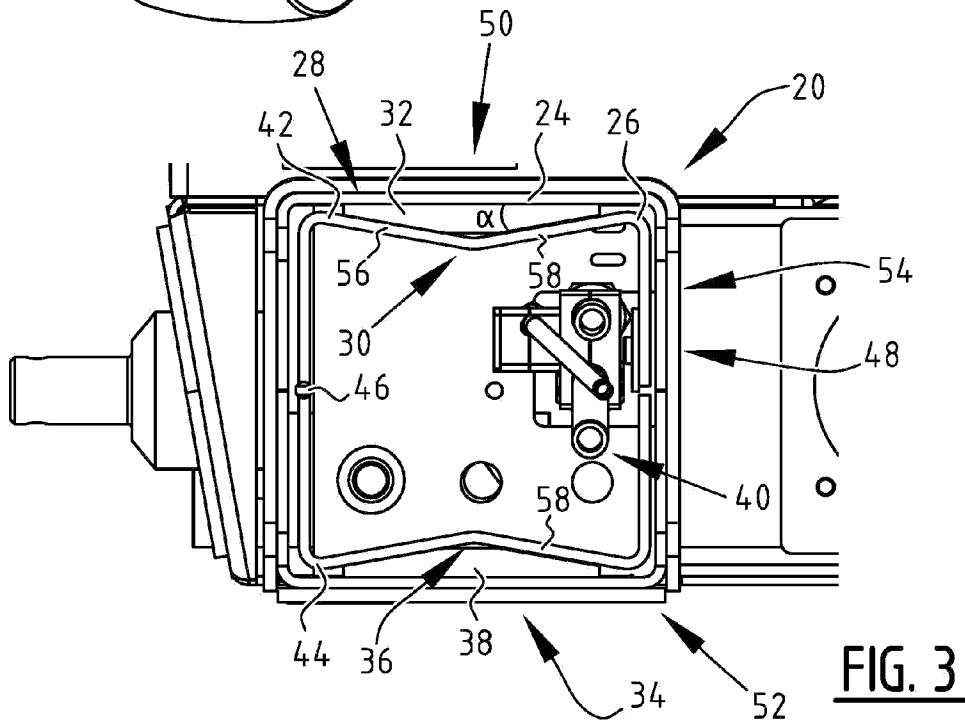
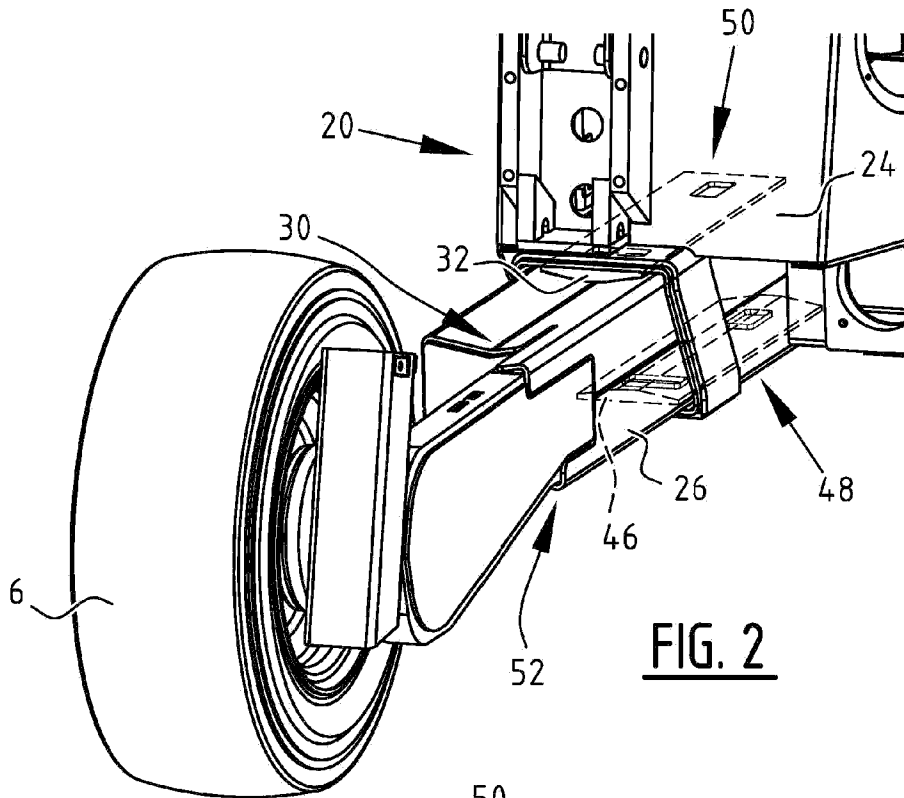

FIG. 1



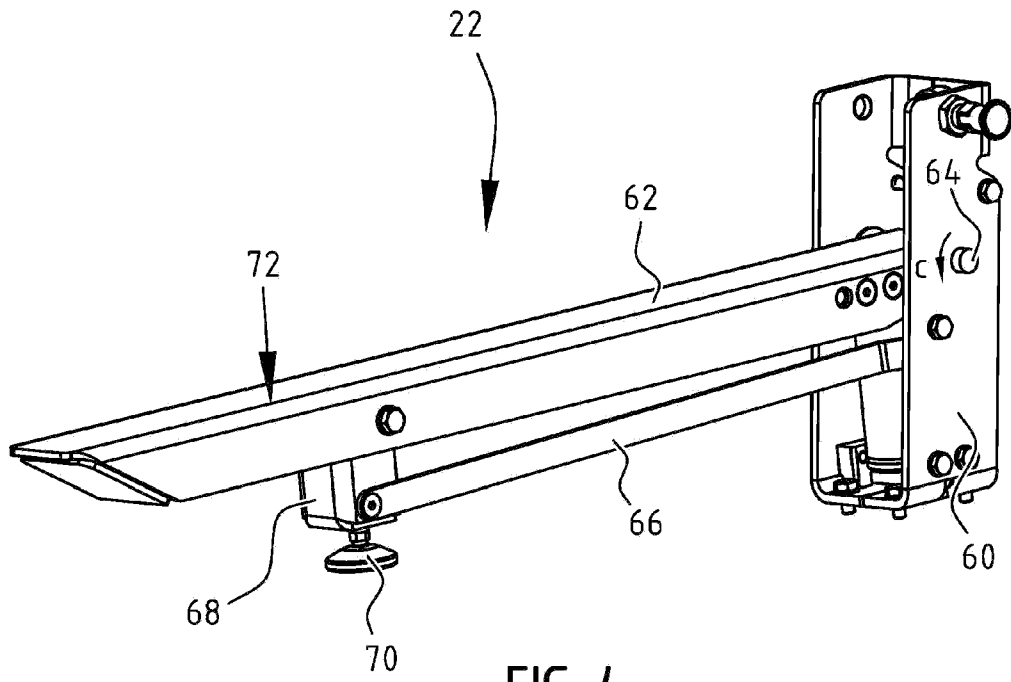

FIG. 4

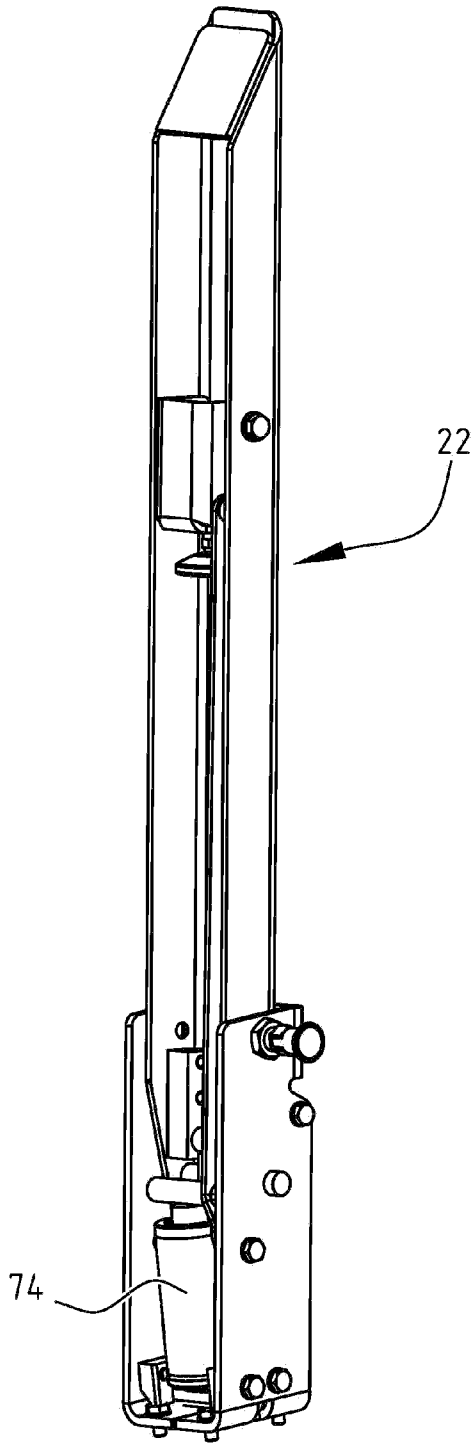

FIG. 5