

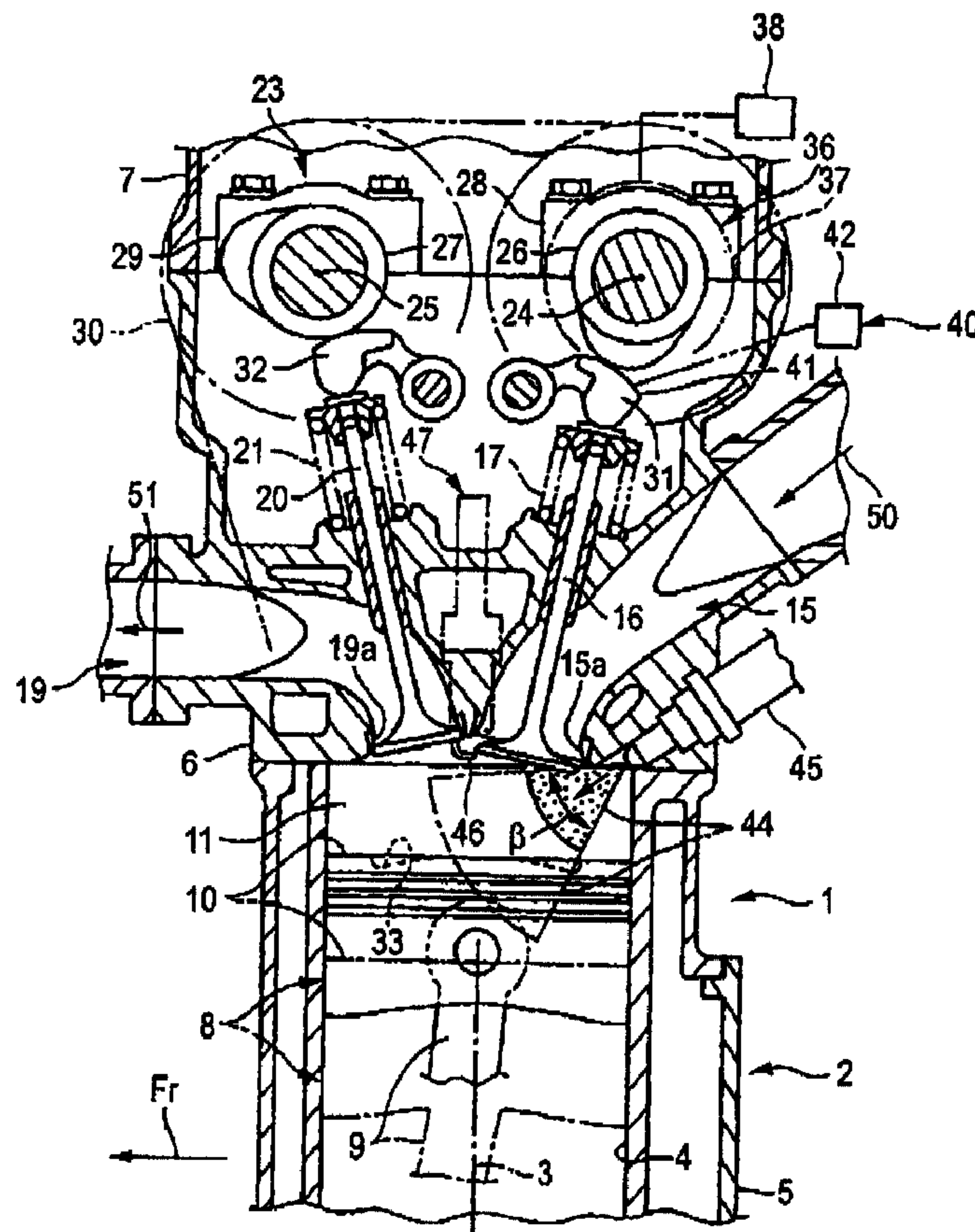

(86) Date de dépôt PCT/PCT Filing Date: 2003/02/28
 (87) Date publication PCT/PCT Publication Date: 2003/09/04
 (45) Date de délivrance/Issue Date: 2008/12/30
 (85) Entrée phase nationale/National Entry: 2004/08/27
 (86) N° demande PCT/PCT Application No.: JP 2003/002392
 (87) N° publication PCT/PCT Publication No.: 2003/072934
 (30) Priorité/Priority: 2002/02/28 (JP2002-054358)

(51) Cl.Int./Int.Cl. *F02B 23/10* (2006.01),
F02B 17/00 (2006.01), *F02D 13/02* (2006.01),
F02M 61/14 (2006.01)
 (72) Inventeurs/Inventors:
 TANAKA, DAIJIRO, JP;
 SUZUKI, YUICHI, JP
 (73) Propriétaire/Owner:
 YAMAHA HATSUDOKI KABUSHIKI KAISHA, JP
 (74) Agent: G. RONALD BELL & ASSOCIATES

(54) Titre : MOTEUR A COMBUSTION INTERNE A INJECTION DIRECTE
 (54) Title: DIRECT INJECTION INTERNAL COMBUSTION ENGINE



(57) Abrégé/Abstract:

A cylinder head has an intake passage in one side part thereof and an exhaust passage in the other side part thereof as viewed in a side view of a cylinder in which the axis of a cylinder bore in an internal combustion engine is coincident with a vertical line. A fuel

(57) **Abrégé(suite)/Abstract(continued):**

injection valve is provided which can inject fuel obliquely downward from an outer side of the one side part of the cylinder head into the cylinder bore. A spark plug is located generally on the axis of the cylinder bore with its discharging part positioned in the cylinder bore. The fuel injected from the fuel injection valve forms a V-shape with the discharging part between them as viewed in a plan view of the cylinder. The fuel injection valve injects the fuel during an intake stroke. According to the above constitution, high fuel efficiency can be achieved with reliability even when the average air-fuel ratio of the air-fuel mixture in the cylinder bore is high, in other words, the air-fuel mixture is lean as a whole, such as when the internal combustion engine is operating at low load.

ABSTRACT

A cylinder head has an intake passage in one side part thereof and an exhaust passage in the other side part thereof as viewed in a side view of a cylinder in which the axis of a cylinder bore in an internal combustion engine is coincident with a vertical line. A fuel injection valve is provided which can inject fuel obliquely downward from an outer side of the one side part of the cylinder head into the cylinder bore. A spark plug is located generally on the axis of the cylinder bore with its discharging part positioned in the cylinder bore. The fuel injected from the fuel injection valve forms a V-shape with the discharging part between them as viewed in a plan view of the cylinder. The fuel injection valve injects the fuel during an intake stroke. According to the above constitution, high fuel efficiency can be achieved with reliability even when the average air-fuel ratio of the air-fuel mixture in the cylinder bore is high, in other words, the air-fuel mixture is lean as a whole, such as when the internal combustion engine is operating at low load.

DIRECT INJECTION INTERNAL COMBUSTION ENGINE

Technical Field

This invention relates to a direct injection internal combustion engine in which fuel is directly injected into a cylinder bore from a fuel injection valve.

Background Art

One internal combustion engine of the above type is disclosed in JP-A-2000-345944.

The internal combustion engine according to the patent document has a cylinder head having an intake passage in one side part thereof and an exhaust passage in the other side part thereof, a fuel injection valve which can inject fuel obliquely downward from an outer side of the one side part of the cylinder head into the cylinder bore, and a spark plug located approximately on the axis of the cylinder bore and having a discharging part positioned in the cylinder bore.

When the internal combustion engine is operated, fuel injected from the fuel injection valve during a compression stroke collides with the top surface of the piston and is directed toward the discharging part as shown in particular in FIGS. 7 and 8 in the patent document. In other words, a rich air fuel mixture layer is directed toward the discharging part to achieve ignition which reliability in the internal combustion engine. This is known as a stratified charge combustion method.

When stratified charge combustion is established, ignition can be reliably achieved as described above and greater fuel efficiency can be achieved even when the average air-fuel ratio of the air-fuel mixture in the cylinder bore is high, in other words, the air-fuel mixture is lean as a whole, such as during low load operation.

In the prior art described above, the fuel injected from the fuel injection valve is directed toward the axis (center) of the cylinder bore. Thus, the air-fuel ratio of the air-fuel mixture

in the area close to the inside surface of the cylinder bore tends to be high, that is, lean. As a result, it takes time until a flame is propagated through the air-fuel mixture in the area close to the inside surface of the cylinder bore, which may cause knocking in this area. To avoid the knocking, the compression ratio cannot be high. This is not preferable since the fuel efficiency is decreased.

This invention has been made in view of the above circumstances and it is, therefore, an object of this invention to provide an internal combustion engine which has a high compression ratio and operates with high fuel efficiency even when the average air-fuel ratio of the air-fuel mixture in the cylinder bore is high, in other words, the air-fuel mixture is lean as a whole, such as during low load operation.

15 Disclosure of the Invention

This invention provides a direct injection internal combustion engine comprising: a cylinder having a cylinder bore with an axis; a cylinder head having an intake passage in one side part thereof and an exhaust passage in the other side part thereof as viewed in a side view of the cylinder in which the axis of the cylinder bore is coincident with a vertical line; a fuel injection valve which can inject fuel obliquely downward from an outer side of the one side part of the cylinder head into the cylinder bore; and a spark plug located generally on the axis of the cylinder bore and having a discharging part positioned in the cylinder bore, in which the fuel injected from the fuel injection valve form a V-shape with the discharging part between them as viewed in a plan view of the cylinder and are spread out in the shape of a sector as viewed in the side view of the cylinder, and the fuel injection valve is configured to inject the fuel during an intake stroke.

In the above invention, the internal combustion engine may further comprise a variable valve timing device for changing the timing of opening and closing of at least one of an intake valve

and an exhaust valve and a variable valve lift device for changing the lift of at least one of the intake valve and the exhaust valve. Or, the internal combustion engine may comprise at least one of the devices.

5 Brief Description of the Drawings

FIG. 1 is a partial cross-sectional side view of an internal combustion engine;

FIG. 2 is a plan view of a piston; and

FIG. 3 is a front view of a fuel injection valve.

10

Best Mode for Carrying Out the Invention

Description will be hereinafter made of this invention in detail with reference to the accompanying drawings.

15

In the drawings, a reference numeral 1 denotes an internal combustion engine mounted on a vehicle such as a motorcycle or an automobile. The internal combustion engine 1 is parallel multi-cylinder, four-stroke engine.

20

The internal combustion engine 1 has a crankcase supported by a stationary member such as a vehicle body and supporting a crankshaft (not shown) and cylinders 2 extending upward from the crankcase.

25

Each of the cylinders 2 has a cylinder body 5 having a cylinder bore 4 extending upward from the crankcase and having a axis 3 coincident with a vertical line, a cylinder head 6 removably fixed to an upper end of the cylinder body 5 to close the opening at the upper end of the cylinder bore 4, a cylinder head cover 7 fixed to an upper surface of the cylinder head 6, a piston 8 inserted in the cylinder bore 4 for sliding movement in the axial direction of the cylinder bore 4, and a connecting rod 9 for operatively connecting the piston 8 and the crankshaft. The space defined by the inside surface of the cylinder bore 4, a lower surface of the cylinder head 6, and a top surface 10 of the piston 8 when the piston 8 is in the top dead center position is a combustion chamber 11.

30

Here, in a side view of the cylinder 2 (FIG. 1), a horizontal direction perpendicular to the axis 3 indicated by the arrow Fr indicates the front of the internal combustion engine, and the references to right and left are from the perspective looking in the direction of the arrow Fr.

5 As shown in the side view of the cylinder 2 (FIG.1), the cylinder head 6 has an intake passage 15 for communicating the outside of the cylinder head 6 to the combustion chamber 11 in one side (rear) part thereof. A pair of right and left intake valves 16 which can open and close right and left openings 15a to the combustion chamber 11 of the intake passage 15, respectively, are supported by the cylinder head 6. The openings 15a are led from the intake passage 15 and branched to right and left within the cylinder head 6. Each of the intake valves 16 has a spring 17 for elastically urging it in a direction to close the corresponding opening 15a from the side of the combustion chamber 11.

The cylinder head 6 has an exhaust passage 19 for communicating the combustion chamber 11 to the outside of the cylinder head 6 in the other side (front) part thereof. The exhaust passage 19 has a pair of right and left openings 19a to the combustion chamber 11, and a pair of right and left exhaust valves 20 which can open and close the right and left openings 19a, respectively, are supported by the cylinder head 6. Each of the exhaust valves 20 has a spring 21 for elastically urging it in a direction to close the corresponding opening 19a from the side of the combustion chamber 11.

The internal combustion engine 1 has a valve mechanism 23 operatively connected to the crankshaft for opening and closing the intake valves 16 and the exhaust valves 20 at predetermined crank angles.

The valve mechanism 23 has intake and exhaust camshafts 26 and 27 longitudinally disposed and having axes 24 and 25, respectively, extending in the lateral direction, bearings 28 and 29 for supporting the intake and exhaust camshafts 26 and 27 on

the cylinder head 6 for rotation about the axes 24 and 25, respectively, chain type power transmission means 30 for operatively connecting the intake and exhaust camshafts 26 and 27 to the crankshaft, and locker arms 31 and 32 for engaging the intake and exhaust valves 16 and 20 with the intake and exhaust camshafts 26 and 27, respectively.

When the crankshaft is driven, the intake and exhaust camshafts 26 and 27 are rotated by the crankshaft via the power transmission means 30. Then, the intake and exhaust valves 16 and 20, which are in engagement with the intake and exhaust camshafts 26 and 27 via the locker arms 31 and 32, respectively, are opened and closed at predetermined crank angles.

To improve the compression ratio in the internal combustion engine 1, the capacity of the space between the lower surface of the cylinder head 6 and the top surface 10 of the piston 8 is small. That is, the lower surface of the cylinder head 6 and the top surface 10 of the piston 8 are close to each other when the piston 8 is in the top dead center position. The top surface 10 of the piston 8 has shallow recesses 33 which can receive the lower ends (valve elements) of the intake and exhaust valves 16 and 20 at positions corresponding thereto so that the lower ends of the intake and exhaust valves 16 and 20 cannot be brought into contact with the top surface 10 of the piston 8 reaching the top dead center position when the intake and exhaust valves 16 and 20 are opened and closed.

The valve mechanism 23 has a variable valve timing device 36 of a known type for changing the timing (crank angles) at which the intake valve 16 is opened and closed. The variable valve timing device 36 has a hydraulic variable mechanism 37 interposed between the intake camshaft 26 and the power transmission means 30, and control means 38 for electronically controlling the hydraulic variable mechanism 37. When the hydraulic variable mechanism 37 is operated by the control means 38, the timing of opening and closing of the intake valves 16, which are in engagement with the intake camshaft 26, is advanced

or retarded.

The valve mechanism 23 has a variable lift device 40 of a known type for changing the lift of the intake valves 16. The variable valve lift device 40 has a variable mechanism 41 for changing the engagement state between the intake valves 16 and the intake camshaft 26, and control means 42 for electronically controlling the variable mechanism 41. When the variable mechanism 41 is operated by the control means 42, the lift of the intake valves 16, which are in engagement with the intake camshaft 26, is increased or decreased.

A fuel injection valve 45 is provided which can inject fuel jets 44 obliquely downward from an outer side of the one side (rear) part of the cylinder head 6 into the cylinder bore 4. The fuel injection valve 45 is supported by the cylinder head 6. A spark plug 47 is located approximately on the axis 3 of the cylinder bore 4 with a discharging part 46 positioned in the combustion chamber 11 in the cylinder bore 4. The spark plug 47 is also supported by the cylinder head 6. An engine control device (not shown) is provided for electronically controlling the control means 38 and 42, the fuel injection valve 45 and the spark plug 47.

The fuel injection valve 45 has a pair of right and left injection nozzles 49 for injecting the fuel 44. Each injection nozzle 49 has an opening which has a vertically long rectangular shape. A pair of jets of the fuel 44 injected from the injection nozzles 49 form a V-shape with the discharging part 46 between them as seen in a plan view of the cylinder 2 (FIG. 2). In other words, the jets get farther apart from each other as they go downstream. The injection nozzles 49 preferably have a width W of 100 to 200 μm . The center lines of the fuel jets 44 make an angle α of about 35° . A preferable range of the angle α is 30 to 50° .

Since the width W of the injection nozzles 49 is as very small as 100 to 200 μm as described above, the fuel 44 injected from the injection nozzles 49 have a high injection speed. Thus,

the fuel 44 is atomized first and can be easily ignited. Also, the ability of the fuel 44 to travel in one direction toward desired positions in the cylinder bore 4 is improved, so that the fuel 44 can reach desired positions more reliably.

5 The jets of the fuel 44 injected from the fuel injection valve 45 are spread out in the shape of a sector as seen in a side view of the cylinder 2 (FIG. 1). The injected fuel 44 are spread out at an angle β of about 75° . A preferable range of the angle β is 60 to 80° .

10 When the internal combustion engine 1 is operated, the intake and exhaust valves 16 and 20 are opened and closed by the crankshaft via the valve mechanism 23. Then, atmospheric air 50 is sucked into the cylinder bore 4 through the intakes passage 15 and the fuel 44 are injected from the fuel injection valve 45 into the cylinder bore 4 to produce an air-fuel mixture during
15 an intake stroke based on the opening and closing of the valves. The air-fuel mixture is compressed during the compression stroke following the intake stroke.

20 Then, the compressed air-fuel mixture is ignited by the discharging part 46 of the spark plug 47 and combusted in the combustion chamber 11. Combustion gas generated by the combustion is exhausted through the exhaust passage 19 as exhaust gas 51. The driving force of the internal combustion engine 1 generated by the combustion in the combustion chamber 11 is transmitted to the crankshaft and used to drive the vehicle.

25 When the internal combustion engine 1 is operated at a high speed, the timing (crank angles) at which the intake valves 16 are opened and closed is retarded by the variable valve timing device 36 to increase the output of the engine. Also, the lift of the intake valves 16 is increased by the variable valve lift device 40 to increase the amount of air 50 to be sucked into the
30 cylinder bore 4. A variable valve timing device and a valve lift device for the exhaust valves 20 may be provided instead of or in addition to the variable valve timing device 36 and the variable valve lift device 40 for the intake valves 16.

The operation of the internal combustion engine 1 will be described in further detail. When the piston 8 is in the top dead center position or immediately after the piston 8 starts descending from the top dead center position during an intake stroke, the fuel injection valve 45 starts injecting the fuel 44 into the combustion chamber 11 in the cylinder bore 4 (as shown in solid lines in FIGS. 1 and 2). The fuel injection valve 45 continues to inject the fuel 44 until the piston 8 reaches a point between the top and bottom dead center positions.

As described before, the fuel injection valve 45 injects the fuel 44 into the cylinder bore 4 from the side of the intake passage 15 for introducing the air 50 into the cylinder bore 4 as shown in the side view of the cylinder 2 (FIG. 1). Since the fuel 44 injected from the injection valve 45 do not have to travel against the air 50 flowing into the cylinder bore 4 through the intake passage 15, the fuel 44 are not disturbed and travels in the direction in which they have been injected with its shape unchanged.

Also, the fuel 44 injected from the fuel injection valve 45 form a V-shape with the discharging part 46 between them, and the piston 8 moved downward from the top dead center position during an intake stroke of the internal combustion engine 1. Thus, the direction in which the piston 8 moves and the direction in which the fuel injection valve 45 injects the fuel jets 44 are both downward.

Thus, the fuel 44 injected from the fuel injection valve 45 pass the sides of the discharging part 46 and are prevented from colliding with the top surface 10 of the piston 8. As a result, the fuel 44 travels in the direction in which they have been injected smoothly (as shown by dot-dash lines in FIGS. 1 and 2.).

When the tips of the jet of the fuel 44 reach the inside surface of the cylinder bore 4 and the top surface 10 of the piston 8, the fuel 44 are guided by the surfaces. Then, parts of the fuel 44 flow along the inside surface of the cylinder bore 4 and approach each other in the circumferential direction of the

inside surface of the cylinder bore 4 (as shown by double-dot-dash lines in FIG. 2). The other parts of the fuel 44 flow along the inside surface of the cylinder bore 4 and are separated from each other in the circumferential direction of the inside surface of the cylinder bore 4.

5 Then, most of the fuel 44 injected into the cylinder bore 4 is gathered in the area close to the inside surface of the cylinder bore 4 during an intake stroke and a subsequent compression stroke such that the concentration of the fuel becomes generally uniform in the circumferential direction of the
10 inside surface of the cylinder bore 4. In other words, a rich air-fuel mixture layer 52 with a doughnut shape around the axis 3 of the cylinder bore 4 and a lean air-fuel mixture layer 53 surrounded by the rich air-fuel mixture layer 52 and located in the vicinity of the discharging part 46 are formed in the
15 cylinder bore 4 as seen in the plan view of the cylinder 2 (FIG. 2).

At the last stage of the compression stroke, the lean air-fuel mixture layer 53 is ignited by the discharging part 46 of the spark plug 47. Since the lean air-fuel mixture layer 53 is
20 generated over a large crank angle span during an intake stroke and a compression stroke, in other words, since the lean air-fuel mixture layer 53 takes a long time to be generated, it is prevented that the air-fuel ratio of the lean air-fuel mixture layer 53 cannot be significantly higher than that of the rich
25 air-fuel mixture layer 52.

Thus, the lean air-fuel mixture layer 53 has a relatively low air-fuel ratio and can be reliably ignited. When the lean air-fuel mixture layer 53 is ignited, the flame is immediately propagated through the rich air-fuel mixture layer 52 surrounding
30 the lean air-fuel mixture layer 53 and having an air-fuel ratio lower than that of the lean air-fuel mixture layer 53.

Thus, it is possible to prevent occurrence of knocking in the rich air-fuel mixture layer 52, which corresponds to an end gas. Therefore, high fuel efficiency can be achieved with

reliability even when the average air-fuel ratio of the air-fuel mixture in the cylinder bore 4 is high, in other words, the air-fuel mixture is lean as a whole, such as when the internal combustion engine 1 is operating at low load.

Also, the internal combustion engine 1 has the variable valve timing device 36 for changing the timing of opening and closing of at least either of the intake valves 16 and the exhaust valves 20 and the variable valve lift device 40 for changing the lift of at least either of the intake valves 16 and the exhaust valves 20. Or, the internal combustion engine 1 has at least one of the devices 36 and 40.

Thus, when the movements of the intake valves 16 and the exhaust valves 20 are controlled with the variable valve timing device 36 or the variable valve lift device 40 so that the lower ends of the intake and exhaust valves 16 and 20 cannot be brought into contact with the top surface 10 of the piston 8 when the intake and exhaust valves 16 and 20 are opened and closed while the internal combustion engine 1 is being operated, the depth of the recesses 33 formed in the top surface 10 of the piston 8 can be smaller and shape of the top surface 10 of the piston 8 can be simpler.

When the top surface 10 of the piston 8 has a simpler and flatter shape, the fuel jets 44 injected from the fuel injection valve 45 can be guided by the top surface 10 of the piston 8 more precisely and formed into the rich air-fuel mixture layer 52 with a desired doughnut shape. Thus, occurrence of knocking can be prevented more reliably. Accordingly, the compression ratio can be higher and the fuel efficiency can be further improved.

Additionally, when the depth of the recesses 33 can be smaller, the capacity of the recesses 33 can be smaller. This means that the capacity of the combustion chamber 11 at the time when the piston 8 is in the top dead center position can be smaller. Thus, the compression ratio can be further increased and the fuel efficiency can be improved more reliably.

The jets of the fuel 44 injected from the fuel injection

valve 45 are spread out in the shape of a sector as seen in a side view of the cylinder 2 (FIG. 1) as described before.

Thus, the fuel 44 injected from the fuel injection valve 45 tends to follow every part of the inside surface of the cylinder bore 4 with a uniform air-fuel ratio as compared with when they are simply formed in a conical shape.

Thus, the rich air-fuel mixture layer 52 can be formed into a desired doughnut shape more reliably. Therefore, occurrence of knocking can be prevented more reliably and the fuel efficiency can be improved more reliably.

The above description is based on the illustrated example. The axis 3 of the cylinders 2 of the actual internal combustion engine 1 may be inclined with respect to a vertical line.

This invention may be accomplished by combining the component parts as described above.

THE EMBODIMENTS OF THE INVENTION IN WHICH AN EXCLUSIVE PROPERTY OR PRIVILEGE IS CLAIMS ARE DEFINED AS FOLLOWS:

1. A direct injection internal combustion engine comprising: a cylinder having a cylinder bore with an axis; a cylinder head having an intake passage in one side part thereof and an exhaust passage in the other side part thereof as viewed in a side view of the cylinder in which the axis of the cylinder bore is coincident with a vertical line; an intake valve which opens and closes the intake passage; an exhaust valve which opens and closes the exhaust passage; a fuel injection valve which can inject fuel obliquely downward from an outer side of the one side part of the cylinder head into the cylinder bore; and a spark plug located generally on the axis of the cylinder bore and having a discharging part positioned in the cylinder bore;

wherein the fuel injection valve comprises a pair of injection orifices, each injection orifice having a major axis and a minor axis, and a tip that forms a V-shaped spray pattern having a first leg and a second leg, the electrode being positioned between the first leg and the second leg and each leg having a generally fan configuration when viewed in a direction transverse to the center axis, and wherein the fuel injection valve is configured to inject the fuel during an intake stroke.

2. The direct injection internal combustion engine as set forth in claim 1, further comprising a variable valve timing device for changing the timing of opening and closing of at least one of the intake valve and the exhaust valve and a variable valve lift device for changing the lift of at least one of the intake valve and the exhaust valve, or at least one of the devices.

3. The direct injection internal combustion engine as set forth in claim 1, wherein in the cylinder head, an oblique angle of the intake passage with respect to the axis of the cylinder bore is smaller than that of the exhaust passage as viewed in the side view, and a bottom surface of the intake passage at the side of the cylinder bore is curved to be convex upward as viewed in the side view and smoothly extend toward an upstream side of the intake passage.

4. The direct injection internal combustion engine as set forth in claim 1, wherein the fuel injection valve is disposed below the intake passage in the cylinder head, and wherein an oblique angle of the intake passage with respect to the axis of the cylinder bore is smaller than that of the fuel injection valve as viewed in the side view.

5. The direct injection internal combustion engine as set forth in claim 1, wherein in the vicinity of the one side part of the cylinder head, the intake passage is defined only by an inner surface of the cylinder head and an inner surface of an intake pipe connected to the cylinder head .
6. The direct injection internal combustion engine as set forth in any one of claims 1 to 5, wherein the fuel injection valve comprises a pair of right and left injection nozzles each of which has a vertically long rectangular shape and has a width (W) of 100 μm to 200 μm .
7. The direct injection internal combustion engine as set forth in any one of claims 1 to 5, wherein center lines of the fuel injected in the form of V-shape make an angle (α) of 30° to 50° .
8. The direct injection internal combustion engine as set forth in any one of claims 1 to 5, wherein the injected fuel forms a generally symmetrical V-shape with the discharging part between them as viewed in the plan view.
9. The direct injection internal combustion engine as set forth in any one of claims 1 to 5, wherein the injected fuel are spread out at an angle (β) of 60° to 80° as viewed in the side view.
10. A direct injection internal combustion engine comprising a cylinder comprising a cylinder bore defined by a cylinder wall formed in a cylinder block, the cylinder bore being generally cylindrical with a longitudinally extending center axis, a cylinder head attached to the cylinder block, the cylinder head comprising an intake passage that extends through a first portion of the cylinder head and an exhaust passage that extends through a second portion of the cylinder head, an intake opening being defined at an intersection of the intake passage and a lower surface of the cylinder head, an intake valve being positioned within the intake opening, an exhaust opening being defined at an intersection of the exhaust passage and the lower surface of the cylinder head, an exhaust valve being positioned within the exhaust opening, a fuel injection valve extending through a portion of the cylinder head proximate the first portion of the cylinder head, the fuel injection valve being positioned to inject fuel obliquely downward into the cylinder bore, a spark plug extending through the cylinder head and having an electrode, the electrode being positioned within a region defined among the lower surface of the cylinder head, the cylinder wall and a piston, the electrode being intersected by the center axis, the fuel injection valve comprising a pair of injection orifices, each injection orifice having a major axis and a minor axis, and a tip that forms a V-shaped spray pattern having a first leg and a second leg, the electrode being positioned between the first leg and the second leg and each leg having

a generally fan configuration when viewed in a direction transverse to the center axis, and the engine further comprising a controller that is adapted to initiate fuel injection during an intake stroke of the piston within the cylinder bore.

11. The engine of Claim 10 further comprising a variable valve timing device, the variable valve timing device being configured to change the timing of opening and closing of at least one of the intake valve and the exhaust valve.

12. The engine of Claim 11 further comprising a variable valve lift device, the variable valve lift device being configured to change the lift of at least one of the intake valve and the exhaust valve.

13. The engine of Claim 10 further comprising a variable valve lift device, the variable valve lift device being configured to change the lift of at least one of the intake valve and the exhaust valve.

14. The engine of Claim 10, wherein a majority of the intake passage extends at an angle substantially less than 90 degrees relative to the center axis.

15. The engine of Claim 14, wherein a most downstream portion of the intake passage bends gently toward the combustion chamber and the bend is substantially less than 90 degrees.

16. The engine of Claim 10, wherein the fuel injection valve is positioned generally below the intake passage in the cylinder head and an angle defined between a most downstream portion of the intake passage and the center axis is smaller than an angle defined between an axis of the fuel injection valve and the center axis.

17. The engine of Claim 10, wherein the intake passage further comprises an inner surface of an intake pipe connected to the cylinder head.

18. The engine of Claim 10, wherein the width of each injection orifice along the minor axis is between about 100 μm and about 200 μm .

19. The engine of Claim 10, wherein center lines of the fuel spray pattern originating from the injection orifices assumes a V-shape with an included angle of between about 30° and about 50°.

20. The engine of Claim 18, wherein the injected fuel spray pattern defines a generally symmetrical V-shape comprising a first leg and a second leg with the electrode being positioned between the first leg and the second leg.

21. The engine of Claim 18, wherein the injected fuel spray pattern comprises a fan shape in a plane generally parallel to the center axis, the fan shape comprising an included angle of between about 60° and about 80°.

22. A direct injection internal combustion engine comprising:

a cylinder comprising a cylinder wall that defines a cylinder bore with an axis

a cylinder head comprising an intake passage in a first side part thereof and an exhaust passage in a second side part thereof as viewed in a side view of the cylinder in which the axis of the cylinder bore is substantially coincident with a vertical line;

an intake valve which opens and closes the intake passage;

an exhaust valve which opens and closes the exhaust passage;

a fuel injection valve which can inject fuel obliquely downward from an outer side of the first side part of the cylinder head into the cylinder bore, the fuel injection valve comprising a pair of injection nozzles, each of the nozzles having an elongated rectangular shape;

a spark plug located generally on the axis of the cylinder bore;

the fuel being injected from the fuel injection valve forming a V-shape with the electrode being positioned between two legs of the V-shape as viewed in a plan view of the cylinder;

each of the legs being spread out in the shape of a sector as viewed in the side view of the cylinder; and

a controller being configured to initiate fuel injection through the fuel injection valve during an intake stroke of a piston within the cylinder bore.

23. The engine of Claim 22 further comprising one or more of:

a variable valve timing device for changing the timing of opening and closing of at least one of the intake valve and the exhaust valve; and

a variable valve lift device for changing the lift of at least one of the intake valve and the exhaust valve.

24. The engine of Claim 22, wherein, in the cylinder head, an angle of the intake passage with respect to the axis of the cylinder bore is smaller than that of the exhaust passage as viewed in the side view and a bottom surface of the intake passage at the side of the cylinder bore is curved to be convex upward as viewed in the side view and smoothly extends toward an upstream side of the intake passage.

25. The engine of Claim 22, wherein the fuel injection valve is positioned generally below the intake passage in the cylinder head and an angle of the intake passage with respect to the axis of the cylinder bore is smaller than that of the fuel injection valve with respect to the axis of the cylinder bore as viewed in the side view.

26. The engine of Claim 22, wherein in the vicinity of the one side part of the cylinder head, the intake passage is defined only by an inner surface of a passage integrally formed with the cylinder head and an inner surface of an intake pipe connected to the cylinder head.

27. The engine of Claim 22, wherein at least one of the injection nozzles has a width of between about 100 μm and about 200 μm .

28. The engine of Claim 22, wherein center lines of the fuel spray injected in the form of V-shape make an included angle between about 30° and about 50°.

29. The engine of Claim 22, wherein the spark plug comprises an electrode and the injected fuel spray forms a generally symmetrical V-shape comprising a first leg and a second leg with the electrode being positioned between the legs as viewed in the plan view.

30. The engine of Claim 29, wherein each leg of the injected fuel spray has a sector shape with an included angle of between about 60° and about 80° as viewed in the side view.

31. A direct injection internal combustion engine comprising a cylinder comprising a cylinder bore defined by a cylinder wall, the cylinder bore being generally cylindrical with a longitudinally extending center axis, a cylinder head cooperating with the cylinder wall to at least partially define a combustion chamber, the cylinder head comprising an intake passage that extends through a first portion of the cylinder head and an exhaust passage that extends through a second portion of the cylinder head, a fuel injection valve extending through a portion of the cylinder head, the fuel injection valve comprising a pair of injection nozzles, each injection

nozzle having a major axis and a minor axis, and the fuel injection valve being positioned to inject fuel obliquely downward directly into the cylinder bore, a spark plug extending through the cylinder head and having an electrode that is positioned within the combustion chamber, and means for creating a generally stratified air-fuel charge in which a relatively leaner air-fuel mixture region is provided proximate the electrode of the spark plug and a relatively richer air-fuel mixture region is provided beyond the relatively leaner air-fuel mixture region when the overall air-fuel mixture comprises a higher than stoichiometric air-fuel mixture.

32. The engine of Claim 10, wherein each of the first leg and the second leg of the spray pattern defines a first angle viewed along the center axis and a second angle viewed transverse to the center axis, the first angle of at least one of the first leg and the second leg being smaller than the second angle.

33. The engine of Claim 32, wherein the first angles of both the first leg and the second leg are smaller than the second angles of the first leg and the second leg.

34. The engine of Claim 22, wherein the legs of the spray pattern define a first angle viewed along the center axis and a second angle viewed transverse to the center axis, the first angle of at least one of the first leg and the second leg being smaller than the second angle.

35. The engine of Claim 34, wherein the first angles of both the first leg and the second leg are smaller than the second angles of the first leg and the second leg.

36. A direct injection internal combustion engine comprising:

- a cylinder comprising a cylinder wall, the cylinder wall defining a cylinder bore, the cylinder bore comprising a longitudinal axis;

- a cylinder head connected to the cylinder, a fuel injection valve mounted to the cylinder head, the fuel injection valve disposed to inject fuel obliquely downward into the cylinder bore;

- the fuel injection valve comprising a spray emitting portion, the spray emitting portion consisting of a tip defining two elongated orifices,

- a spark plug located generally on the axis of the cylinder bore;

- the fuel being injected from the spray emitting portion forming a V-shape with the electrode being positioned between two legs of the V-shape as viewed in a plan view of the cylinder;

each of the legs being spread out in the shape of a sector as viewed in a direction normal to the axis of the cylinder; and

a controller being configured to initiate fuel injection through the fuel injection valve during an intake stroke of a piston within the cylinder bore.

FIG. 1

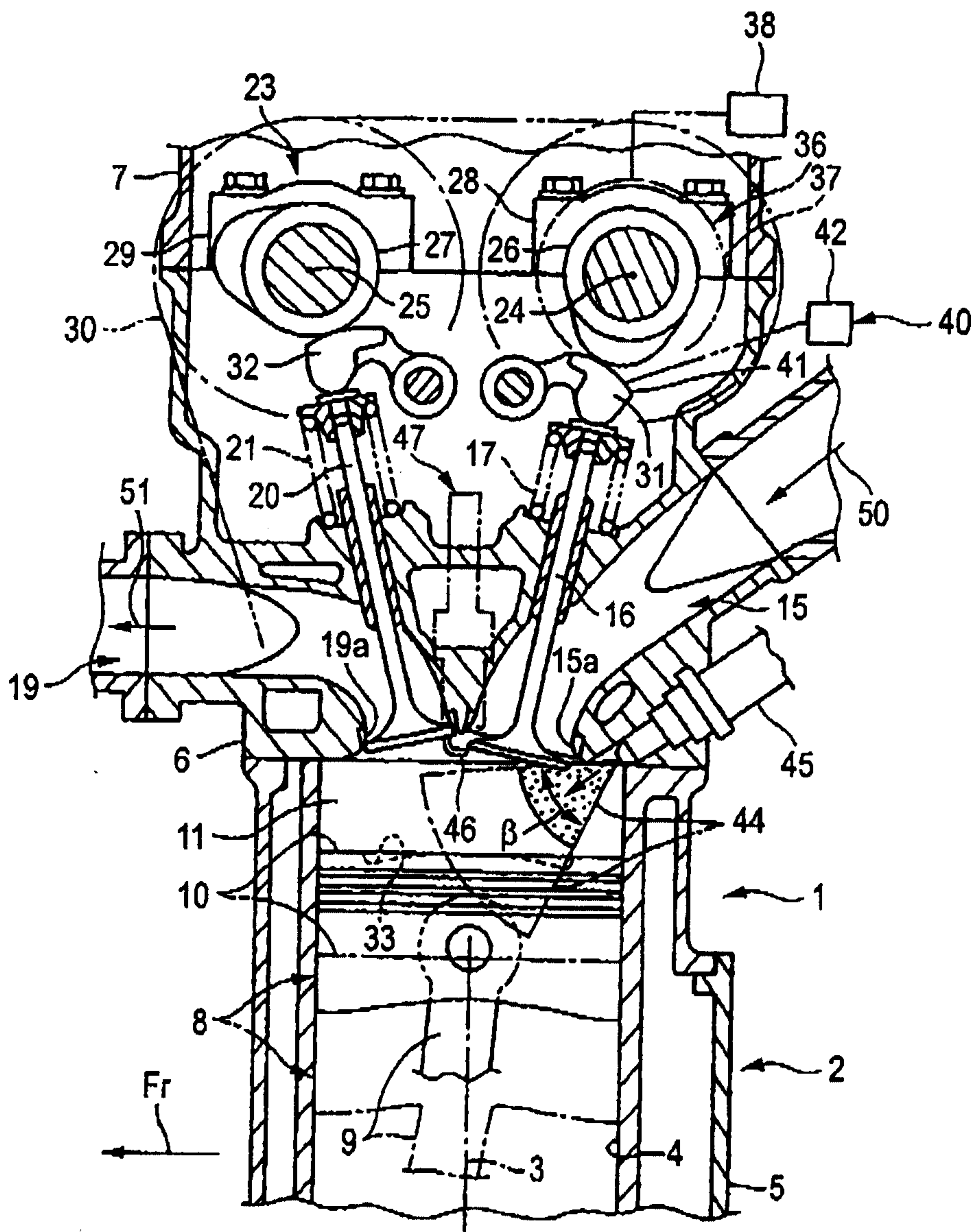

FIG. 2

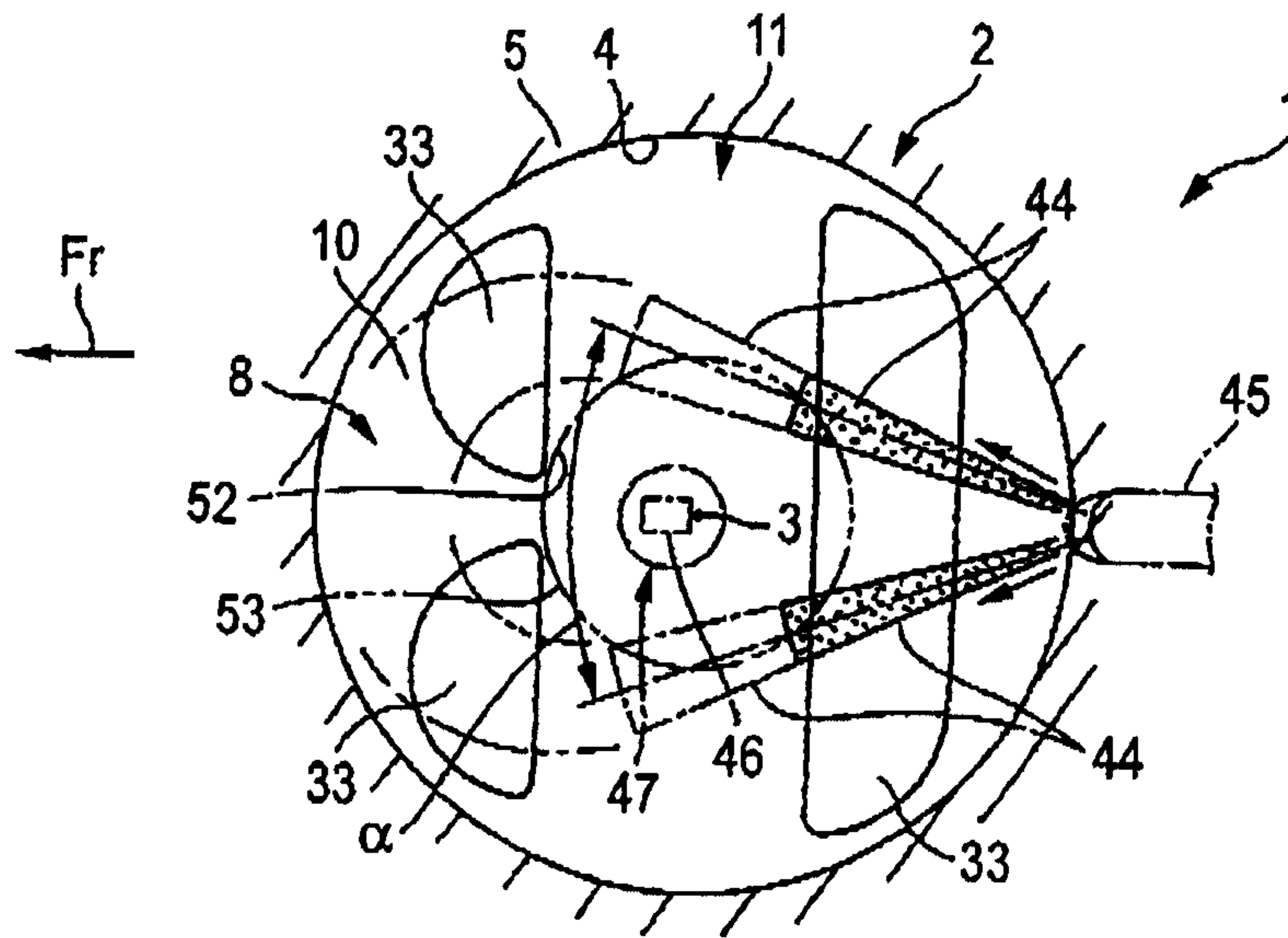

FIG. 3

